



F30B
F40B

OWNER'S MANUAL

U.S.A. Edition
LIT-18626-05-07

⚠ WARNING

The engine exhaust from this product contains chemicals known to the State of California to cause cancer, birth defects or other reproductive harm.

YAMAHA

LIT-CALIF-65-01

TO THE OWNER

Thank you for choosing a Yamaha outboard motor. This Owner's manual contains information needed for proper operation, maintenance and care. A thorough understanding of these simple instructions will help you obtain maximum enjoyment from your new Yamaha. If you have any question about the operation or maintenance of your outboard motor, please consult a Yamaha dealer.

In this Owner's Manual particularly important information is distinguished in the following ways.



The Safety Alert Symbol means **ATTENTION! BECOME ALERT! YOUR SAFETY IS INVOLVED!**

WARNING

Failure to follow WARNING instructions could result in severe injury or death to the machine operator, a bystander, or a person inspecting or repairing the outboard motor.

CAUTION:

A CAUTION indicates special precautions that must be taken to avoid damage to the outboard motor.

NOTE:

A NOTE provides key information to make procedures easier or clearer.

* Yamaha continually seeks advancements in product design and quality. Therefore, while this manual contains the most current product information available at the time of printing, there may be minor discrepancies between your machine and this manual. If there is any question concerning this manual, please consult your Yamaha dealer.

NOTE:

The F40MH, F40TR and their standard accessories are used as a base for the explanations and illustrations in this manual. Therefore, some items may not apply to every model.

**F30B, F40B
OWNER'S MANUAL
©2002 by Yamaha Motor Corporation, USA
1st Edition, April 2002
All rights reserved.
Any reprinting or unauthorized use
without the written permission of
Yamaha Motor Corporation, USA
is expressly prohibited.
Printed in Japan
P/N LIT-18626-05-07**

CONTENTS



GENERAL INFORMATION

1



BASIC COMPONENTS

2



OPERATION

3



MAINTENANCE

4



TROUBLE RECOVERY

5

A to Z

INDEX

6

**READ THIS OWNER'S MANUAL CAREFULLY
BEFORE OPERATING YOUR OUTBOARD MOTOR.**



EMU00004

Chapter 1

GENERAL INFORMATION

1

IDENTIFICATION NUMBERS RECORD ..1-1

Outboard motor serial number1-1

Key number1-1

EMISSION CONTROL INFORMATION...1-2

SAFETY INFORMATION.....1-4

IMPORTANT LABELS1-6

BASIC BOATING RULES1-7

FUELING INSTRUCTIONS.....1-11

Gasoline1-12

ENGINE OIL1-13

BATTERY REQUIREMENT1-14

PROPELLER SELECTION1-15

START-IN-GEAR PROTECTION1-16





EMU00005

IDENTIFICATION NUMBERS RECORD

EMU00007

OUTBOARD MOTOR SERIAL NUMBER

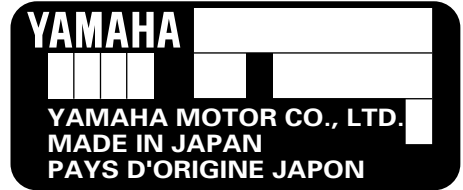
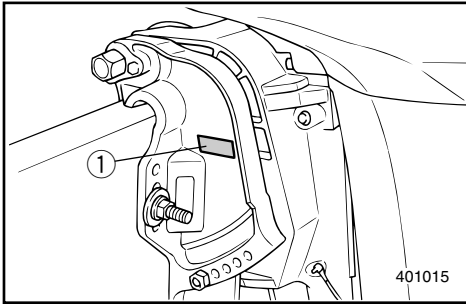

The outboard motor serial number is stamped on the label attached to the port side of the clamp-bracket.

Record your outboard motor serial number in the spaces provided to assist you in ordering spare parts from your Yamaha dealer or for reference in case your outboard motor is stolen.

① Outboard motor serial number

EMU00008

KEY NUMBER

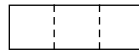

If main key switch is equipped, your key identification number is stamped on your key as shown in the illustration. Record this number in the space provided for reference if you need a new key.

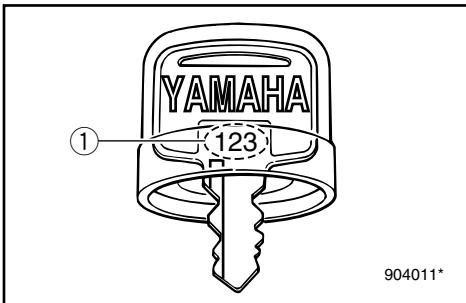

① Key number

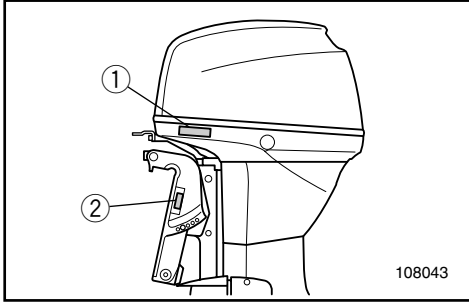

EMU01385

EMISSION CONTROL INFORMATION

EMU01387

NORTH AMERICAN MODELS

This engine conforms to U.S. Environmental Protection Agency (EPA) regulations for marine SI engines. See the label affixed to your engine for details.

Approval label of Emission control certificate

This label is attached to the bottom cowling.

① Emission control information label

EMISSION CONTROL INFORMATION		EM
ENGINE FAMILY :		
THIS ENGINE CONFORMS TO U.S. EPA REGULATIONS FOR MARINE SI ENGINES.		
THIS ENGINE CONFORMS TO CALIFORNIA EMISSION REGULATIONS FOR SI MARINE ENGINES.		
REFER TO THE OWNERS MANUAL FOR MAINTENANCE SPECIFICATIONS AND ADJUSTMENTS.		
FELs : g/kw-hr	IDLE SPEED : rpm IN NEUTRAL	
SPARK PLUG :	SPARK PLUG GAP (mm) :	
DISPLACEMENT : cm ³	FUEL : GASOLINE	
ADVERTISED POWER : kw	VALVE LASH (mm) : IN EX	
YAMAHA MOTOR CO.,LTD.		

New Technology ; (4-stroke) EM

Manufactured date label

This label is attached to the clamp bracket.

② Manufactured date label

YAMAHA

Manufactured:



EMU01389

STAR LABELS

Your outboard motor is labeled with a California Air Resources Board (CARB) star label. See below for a description of your particular label.

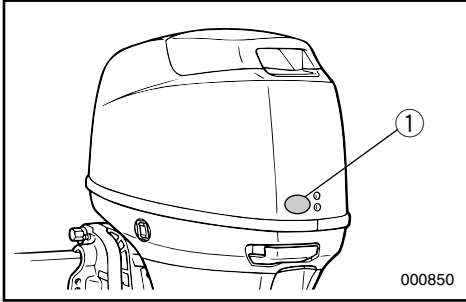

① Star label



One Star - Low Emission

The one-star label identifies engines that meet the Air Resources Board's 2001 exhaust emission standards. Engines meeting these standards have 75% lower emissions than conventional carbureted two-stroke engines. These engines are equivalent to the U.S. EPA's 2006 standards for marine engines.

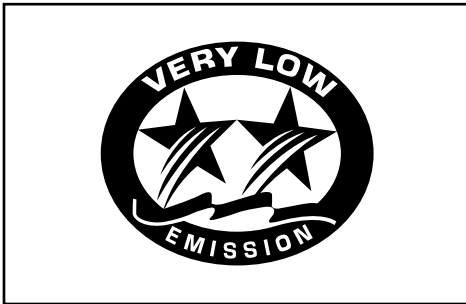

Two Stars - Very Low Emission

The two-star label identifies engines that meet the Air Resources Board's 2004 exhaust emission standards. Engines meeting these standards have 20% lower emissions than One Star-Low-Emission engines.



Three Stars - Ultra Low Emission

The three-star label identifies engines that meet the Air Resources Board's 2008 exhaust emission standards. Engines meeting these standards have 65% lower emissions than One Star-Low-Emission engines.



EMU00917



SAFETY INFORMATION

- Before mounting or operating the outboard motor, read this entire manual. Reading it should give you an understanding of the motor and its operation.
- Before operating the boat, read any owner's or operator's manuals supplied with it and all labels. Be sure you understand each item before operating.
- Do not overpower the boat with this outboard motor. Overpowering the boat could result in loss of control. The rated power of the outboard should be equal to or less than the rated horsepower capacity of the boat. If the rated horsepower capacity of the boat is unknown, consult the dealer or boat manufacturer.
- Do not modify the outboard. Modifications could make the motor unfit or unsafe to use.
- Never operate after drinking alcohol or taking drugs. About 50% of all boating fatalities involve intoxication.
- Have an approved personal flotation device (PFD) on board for every occupant. It is a good idea to wear a PFD whenever boating. At a minimum, children and non-swimmers should always wear PFDs, and everyone should wear PFDs when there are potentially hazardous boating conditions.
- Gasoline is highly flammable, and its vapors are flammable and explosive. Handle and store gasoline carefully. Make sure there are no gas fumes or leaking fuel before starting the engine.
- This product emits exhaust gases which contain carbon monoxide, a colorless, odorless gas which may cause brain damage or death when inhaled. Symptoms include nausea, dizziness, and drowsiness. Keep cockpit and cabin areas well ventilated. Avoid blocking exhaust outlets.
- Check throttle, shift, and steering for proper operation before starting the engine.
- Attach the engine stop switch lanyard to a secure place on your clothing, or your arm or leg while operating. If you accidentally leave the helm, the lanyard will pull from the switch, stopping the engine.
- Know the marine laws and regulations where you will be boating - and obey them. Refer to "RULES OF THE ROAD" section for basic boating rules.
- Stay informed about the weather. Check weather forecasts before boating. Avoid boating in hazardous weather.
- Tell someone where you are going: leave a Float Plan with a responsible person. Be sure to cancel the Float Plan when you return.
- Use common sense and good judgment when boating. Know your abilities, and be sure you understand how your boat handles under the different boating conditions you may encounter. Operate within your limits, and the limits of your boat. Always operate at safe speeds, and keep a careful watch for obstacles and other traffic.
- Always watch carefully for swimmers during the engine operation.
- Stay away from swimming areas.
- When a swimmer is in the water near you shift into neutral and shut off the engine.



- Be informed about boating safety. Additional publications and information can be obtained from many organizations, including the following:

United States Coast Guard

Consumer Affairs Staff (G-BC)
Office of Boating, Public, and Consumer Affairs
U.S. Coast Guard Headquarters
Washington, D.C. 20593-0001
Boating Safety Hotline: 1-800-368-5647

National Marine Manufacturers

Association (NMMA)

401 N. Michigan Ave.
Chicago, IL 60611

Marine Retailers Association of America

155 N. Michigan Ave.
Chicago, IL 60601



EMU00014

IMPORTANT LABELS

WARNING LABELS

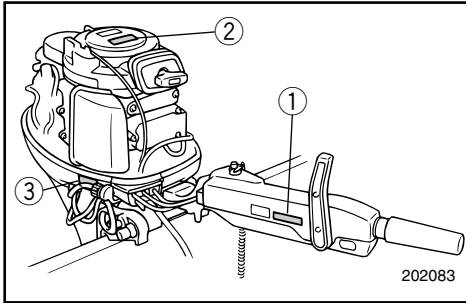

①



WARNING

This engine is equipped with a neutral starting device. The engine will not start unless the shift control is in neutral position.

YAMAHA

6E0-83627-41

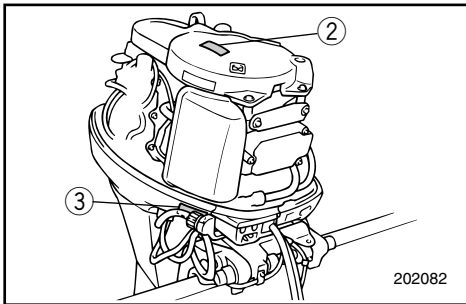

②



WARNING

- Be sure shift control is in neutral before starting engine. (except 2HP)
- Do not touch or remove electrical parts when starting or during operation.
- Keep hands, hair, and clothes away from flywheel and other rotating parts while engine is running.

YAMAHA

6A1-63625-41

CAUTION LABELS

③

CAUTION

Transport and store the engine only as shown. Otherwise, engine damage could result from leaking oil.



YAMAHA

62Y-13444-40



EMU00015

BASIC BOATING RULES

(Rules of the road)

Just as there are rules which apply when you are driving on streets and high ways, there are waterway rules which apply when you are driving your boat. These rules are used internationally, and are also enforced by the United States Coast Guard and local agencies. You should be aware of these rules, and follow them whenever you encounter another vessel on the water.

Several sets of rules prevail according to geographic location, but are all basically the same as the International Rules of the Road. The rules presented here in your Owner's Manual are condensed, and have been provided for your convenience only. Consult your local U.S. Coast Guard Auxiliary or Department of Motor Vehicles for a complete set of rules governing the waters in which you will be using your boat.

STEERING AND SAILING RULES AND SOUND SIGNALS

Whenever two vessels on the water meet one another, one vessel has the right-of-way; it is called the "stand-on" vessel. The vessel which does not have the right-of-way is called the "give-way" or "burdened" vessel. These rules determine which vessel has the right-of-way, and what each vessel should do.

Stand-on vessel

The vessel with the right-of-way has the duty to continue its course and speed, except to avoid an immediate collision. When you maintain your direction and speed, the other vessel will be able to determine how best to avoid you.

Give-way vessel

The vessel which does not have the right-of-way has the duty to take positive and timely action to stay out of the way of the Stand-On vessel. Normally, you should not cross in front of the vessel with the right-of-way. You should slow down or change directions briefly and pass behind the other vessel. You should always move in such a way that the operator of the other vessel can see what you are doing.

"The general prudential rule"

This rule is called Rule 2 in the International Rules and says,

'In obeying and construing these rules due regard shall be had to all dangers of navigation and collision, and to any special circumstances, which may render a departure from the above rules necessary in order to avoid immediate danger.'

In other words, follow the standard rules except when a collision will occur unless both vessels try to avoid each other. If that is the case, both vessels become "Give-Way" vessels.



RULES WHEN ENCOUNTERING VESSELS

There are three main situations which you may encounter with other vessels which could lead to a collision unless the Steering Rules are followed:

Meeting (you are approaching another vessel head-on)

Crossing (you are traveling across the other vessel's path)

Overtaking (you are passing or being passed by another vessel)

In the following illustration, your boat is in the center. You should give the right-of-way to any vessels shown in white area (you are the Give-Way vessel). Any vessels in the shaded area must yield to you (they are the Give-Way vessels). Both you and the meeting vessel must alter course to avoid each other.

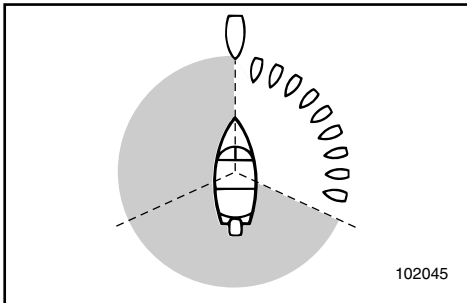

Meeting

If you are meeting another power vessel head on, and are close enough to run the risk of collision, neither of you has the right-of-way! Both of you should alter course to avoid an accident. You should keep the other vessel on your port (left) side. This rule doesn't apply if both of you

will clear one another if you continue on your set course and speed.

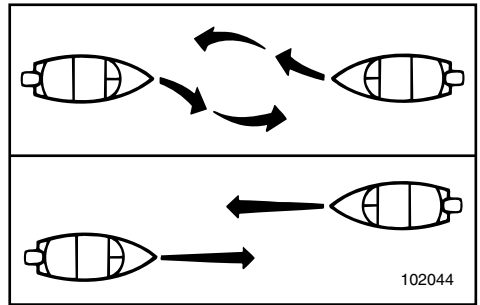

Crossing

When two power driven vessels are crossing each other's path close enough to run the risk of collision, the vessel which has the other on the starboard (right) side must keep out of the way of the other. If the other vessel is on your right, you must keep out of its way; you are the Give-Way vessel. If the other vessel is on your port (left) side, remember that you should maintain course and direction, provided the other vessel gives you the right-of-way as it should.

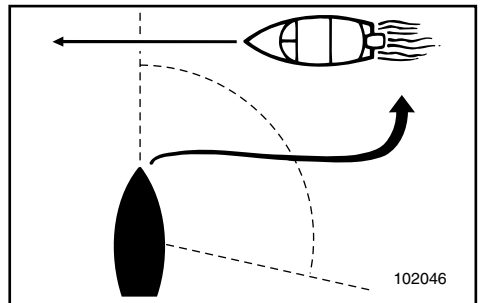

Overtaking

If you are passing another vessel, you are the "Give-Way" vessel. This means that the other vessel is expected to maintain



its course and speed. You must stay out of its way until you are clear of it. Likewise, if another vessel is passing you, you should maintain your speed and direction so that the other vessel can steer itself around you.

OTHER SPECIAL SITUATIONS

There are three other rules you should be aware of when driving your boat around other vessels.

Narrow channels and bends

When navigating in narrow channels, you should keep to the right when it is safe and practical to do so. If the operator of a power-driven vessel is preparing to go around a bend that may obstruct the view of other water vessels, the operator should sound a prolonged blast on the whistle (4 to 6 seconds). If another vessel is around the bend, it too should sound the whistle. Even if no reply is heard, however, the vessel should still proceed around the bend with caution. If you navigate such waters with your boat, you will need to carry a portable air horn, available from local marine supply stores.

Fishing vessel right-of-way

All vessels which are fishing with nets, lines or trawls are considered to be "fishing vessels" under the International Rules. Vessels with trolling lines are not considered fishing vessels. Fishing vessels have the right-of-way regardless of position. Fishing vessels cannot, however, impede the passage of other vessels in narrow channels.

Sailing vessel right-of-way

Sailing vessels should normally be given the right-of-way. The exceptions to this are:

1. When the sailing vessel is overtaking the power-driven vessel, the power-driven vessel has the right-of-way.
2. Sailing vessels should keep clear of any fishing vessel.
3. In a narrow channel, a sailing vessel should not hamper the safe passage of a power-driven vessel which can navigate only in such a channel.

Reading buoys and other markers

The waters of the United States are marked for safe navigation by the lateral system of buoyage. Simply put, buoys and markers have an arrangement of shapes, colors, numbers and lights to show which side of the buoy a boater should pass on when navigating in a particular direction. The markings on these buoys are oriented from the perspective of being entered from seaward (the boater is going towards the port). This means that red buoys are passed on the starboard (right) side when proceeding from open water into port, and black buoys are to port (left) side. When navigating out of port, your position with respect to the buoys should be reversed; red buoys should be to port and black buoys to starboard.

Many bodies of water used by boaters are entirely within the boundaries of a particular state. The Uniform State Waterway Marking System has been devised for these waters. This system uses buoys and signs with distinctive shapes and colors to show regulatory or advisory informa-



tion. These markers are white with black letters and orange borders. They signify speed zones, restricted areas, danger areas, and general information. Remember, markings may vary by geographic location. Always consult local boating authorities before driving your boat in unfamiliar waters.

<p>BUOY COLOR CODE</p> <ul style="list-style-type: none"> BLACK RED GREEN 	<p>MAIN CHANNEL BUOYS</p> <p>◇ "1" "3" "5" "7"</p> <p>○ LIGHTED BUOY (Port Hand)</p> <p>Odd number, increasing toward head of navigation. Leave to port (left) proceeding upstream.</p> <p>White Light OR Green Light</p> <p>old new</p>
<p>SECONDARY CHANNEL BUOYS STARTS NEW NUMBERING SYSTEM</p>	<p>◇ "2" "4" "6"</p> <p>○ LIGHTED BUOY (Starboard Hand)</p> <p>Even number, increasing toward head of navigation. Leave to starboard (right) proceeding upstream.</p> <p>White Light OR Red Light</p> <p>old new</p>
<p>◇ C "1"</p> <p>CAN BUOY</p> <p>Odd number. Leave to port.</p> <p>old OR new</p>	<p>◇ "A"</p> <p>○ LIGHTED SAFE WATER BUOY</p> <p>No number. Marks midchannel, pass on either side. Letter has no lateral significance, used for identification and location purposes.</p> <p>White Light OR Top Mark White Light</p> <p>old new</p>
<p>◇ N "2"</p> <p>NUN BUOY</p> <p>Even number. Leave to starboard</p> <p>No change</p>	<p>◇ RB "L" OR RG "L"</p> <p>○ LIGHTED PREFERRED CHANNEL TO PORT BUOY</p> <p>No number. Topmost band red – preferred channel is to left of buoy. Letter has no lateral significance, used for identification and location purposes.</p> <p>Red or White Light OR Red Light</p> <p>old new</p>



EMU00016

FUELING INSTRUCTIONS

⚠ WARNING

GASOLINE AND ITS VAPORS ARE HIGHLY FLAMMABLE AND EXPLOSIVE!

- Do not smoke when refueling, and keep away from sparks, flames, or other sources of ignition.
- Stop engine before refueling.
- Refuel in a well-ventilated area. Refuel portable fuel tanks off the boat.
- Take care not to spill gasoline. If gasoline spills, wipe it up immediately with dry rags.
- Do not overfill the fuel tank.
- Tighten the filler cap securely after refueling.
- If you should swallow some gasoline inhale a lot of gasoline vapor, or get gasoline in your eyes, get immediate medical attention.
- If any gasoline spills onto your skin, immediately wash with soap and water. Change clothing if gasoline spills on it.
- Touch the fuel nozzle to the filler opening or funnel to help prevent electrostatic sparks.

CAUTION:

Use only new clean gasoline which has been stored in clean containers and is not contaminated with water or foreign matter.



EMU01804

GASOLINE

Recommended gasoline:

Regular unleaded gasoline with a minimum octane rating of 86 (Pump Octane Number) = $(R+M)/2$

If knocking or pinging occurs, use a different brand of gasoline or premium unleaded fuel.

EMU00027

Gasohol

There are two types of gasohol: gasohol containing ethanol and that containing methanol. Gasohol containing ethanol can be used if ethanol content does not exceed 10% and the fuel meets minimum octane ratings. Gasohol containing methanol is not recommended by Yamaha because it can cause fuel system damage or engine performance problems.



EMU01769

ENGINE OIL

Recommended engine oil:

4-stroke motor oil with a combination of corresponding SAE and API as shown in the chart.

SAE				API
-4	32	68	104°F	SE
-20	0	20	40°C	SF
10W-30				SG
10W-40				SH
				SJ

Engine oil quantity:

See Chapter 4, "Specifications."

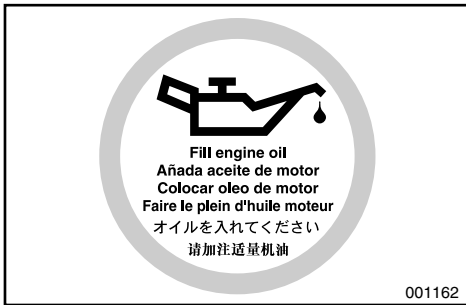

001162

CAUTION:

All 4-stroke engines are shipped from the factory without engine oil.



EMU01775

BATTERY REQUIREMENT

CAUTION: _____

Do not use a battery that does not meet the specified capacity. If a battery which does not meet specifications is used, the electric system could perform poorly or be overloaded, causing electric system damage.

For electric start models, choose a battery which meets the following specifications.

EMU01860

Minimum cold cranking amps
(CCA/SAE):

380 amps at -18°C (-0.4°F)

Minimum marine cranking amps
(MCA/ABYC):

502 amps at 0°C (32°F)

Minimum reserve capacity (RC/SAE):
124 minutes

EMU01783

CAUTION: _____

A battery cannot be connected to models that do not have a rectifier or Rectifier Regulator.

Models without a rectifier or Rectifier

Regulator: F40MH

- **If you wish to use a battery with the above models, install an optional Rectifier Regulator.**
-



PROPELLER SELECTION

The performance of your outboard motor will be critically affected by your choice of propeller, as an incorrect choice could adversely affect performance and could also seriously damage the motor. Engine speed depends on the propeller size and boat load. If engine speed is too high or too low for good engine performance, this will have an adverse effect on the engine.

Yamaha outboard motors are fitted with propellers chosen to perform well over a range of applications, but there may be uses where a propeller with a different pitch would be more appropriate. For a greater operating load, a smaller-pitch propeller is more suitable as it enables the correct engine speed to be maintained. Conversely, a larger-pitch propeller is more suitable for a smaller operating load.

Yamaha dealers stock a range of propellers, and can advise you and install a propeller on your outboard that is best suited to your application.

NOTE: _____

At full throttle and under a maximum boat load, the engine's rpm should be within the upper half of the full throttle operating range, as listed in "SPECIFICATIONS" on page 4-1. Select a propeller which fulfills this requirement.

If operating under conditions which allow the engine's rpm to rise above the maximum recommended range (such as light boat loads), reduce the throttle setting to maintain the rpm in the proper operating range.

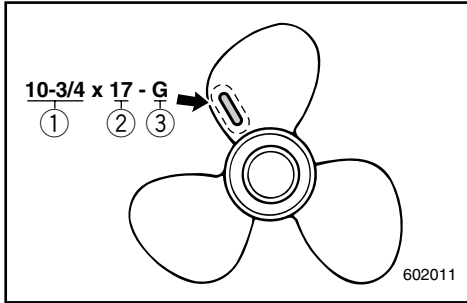

- ① Propeller diameter (in inches)
- ② Propeller pitch (in inches)
- ③ Type of propeller (propeller mark)

Refer to the section "CHECKING PROPELLER" for instructions on propeller removal and installation.

EMU01209

START-IN-GEAR PROTECTION

Yamaha outboard motors or Yamaha approved remote control units are equipped with start-in-gear protection device(s). This feature permits the engine to be started only when it is Neutral. Always select Neutral before starting the engine.



- MEMO -



EMU00037

Chapter 2

BASIC COMPONENTS

MAIN COMPONENTS2-1

**OPERATIONS OF CONTROLS AND
OTHER FUNCTIONS**2-2

Recoil starter handle2-2

Multifunction tiller handle2-2

Remote control2-5

Trim tab2-10

Power trim/tilt switch2-11

Warning indicator(s)2-11

Tachometer2-12

Trim meter2-12

Tilt lock mechanism2-13

Tilt support knob2-13

Top cowling lock lever2-13

Flushing device2-14

WARNING SYSTEM2-15

Overheat warning2-15

Low oil pressure warning2-16

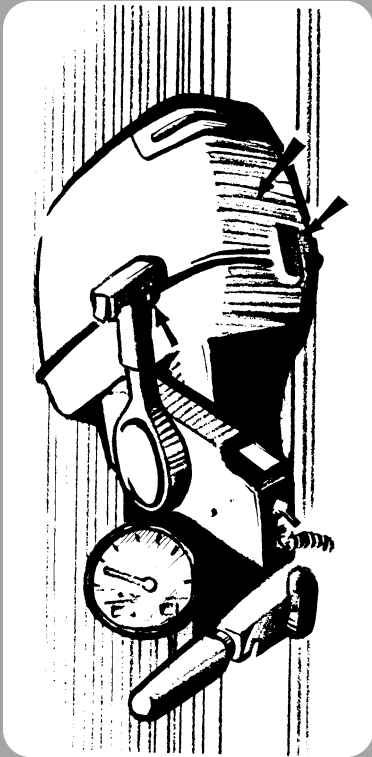



EMU01206

MAIN COMPONENTS

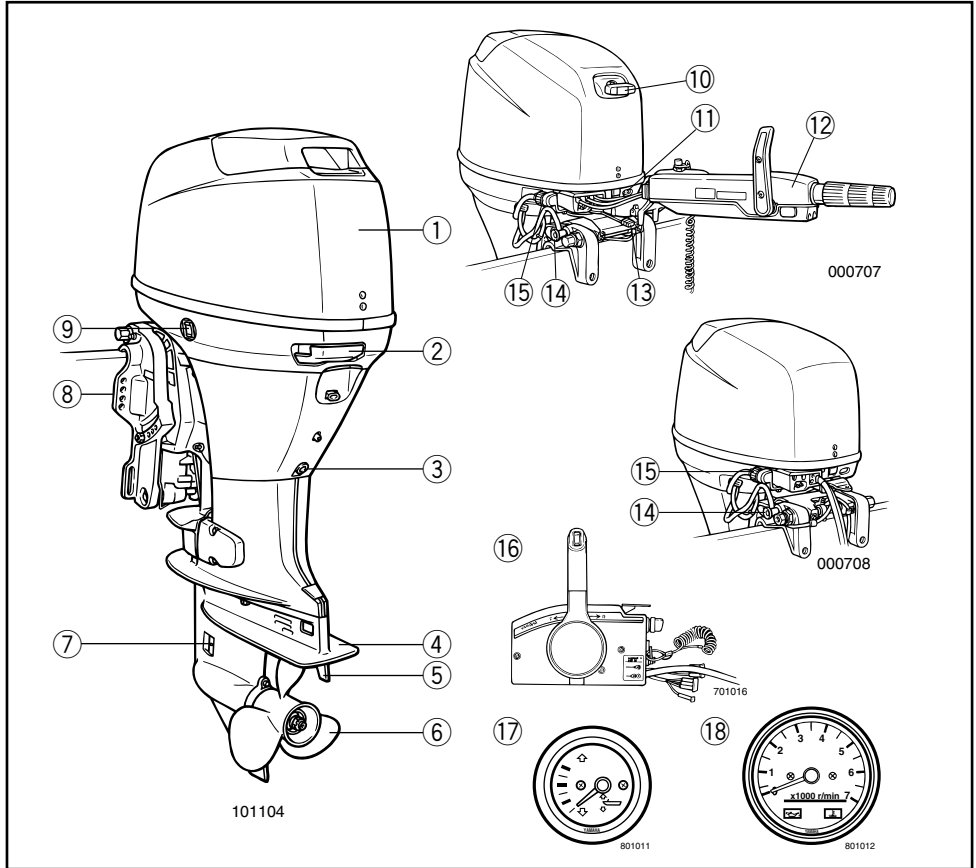

- ① Top cowling
 - ② Top cowling lock lever
 - ③ Oil drain bolt
 - ④ Anti-cavitation plate
 - ⑤ Trim tab
 - ⑥ Propeller
 - ⑦ Cooling water inlet
 - ⑧ Clamp bracket
 - * ⑨ Power trim and tilt switch
 - * ⑩ Recoil starter handle
 - * ⑪ Warning indicators
 - * ⑫ Multifunction tiller handle
 - * ⑬ Steering friction adjusting lever
 - ⑭ Tilt support knob
 - ⑮ Flushing device
 - * ⑯ Remote control box
 - * ⑰ Trim meter
 - * ⑱ Tachometer
- * May not be exactly as shown; also may not be included as standard equipment on all models.

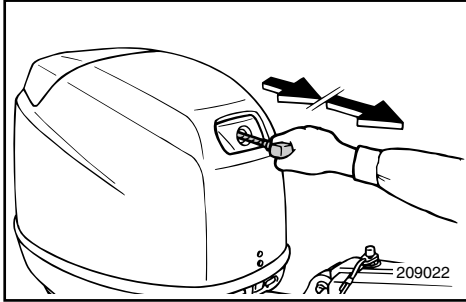

EMU00039

OPERATIONS OF CONTROLS AND OTHER FUNCTIONS

EMU00059

RECOIL STARTER HANDLE (If equipped)

Pull the handle gently until resistance is felt. Then vigorously pull the handle straight out to crank the engine to start it.

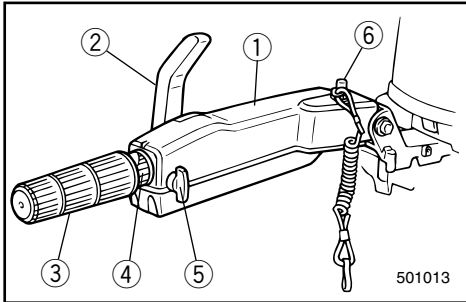

EMU00075

MULTIFUNCTION TILLER HANDLE

The tiller handle centralized most of functions for the outboard motor operation.

- ① Tiller handle
- ② Gear shift lever
- ③ Throttle control grip
- ④ Throttle indicator
- ⑤ Throttle friction adjusting knob
- ⑥ Engine stop lanyard switch / Engine stop button (If equipped)

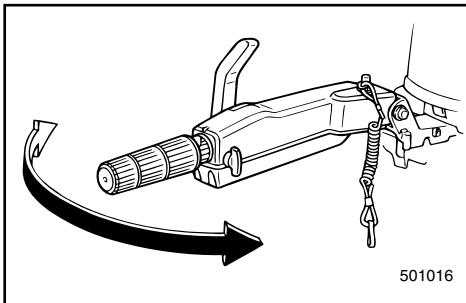

EMU00079

Tiller handle

Moving the tiller handle sideways to adjust the steering direction.

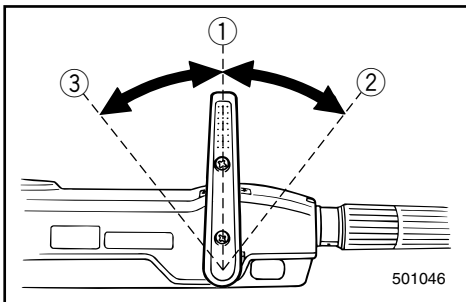

EMU00080

Gear shift lever

Turning the gear-shift lever forward (bow side) engages the clutch with the forward gear so that the boat moves ahead. Turning the lever backward (stern side) engages the reverse gear so that the boat moves astern.

- ① Neutral
- ② Forward
- ③ Reverse

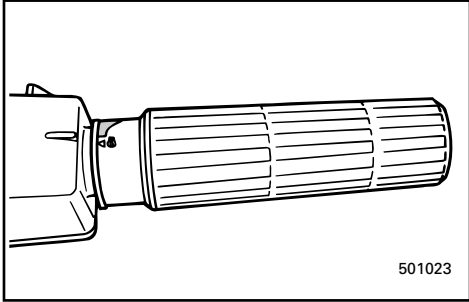

EMU00081

Throttle control grip

The throttle control grip is on the tiller handle. Turn the grip counterclockwise to increase speed and clockwise to decrease speed.

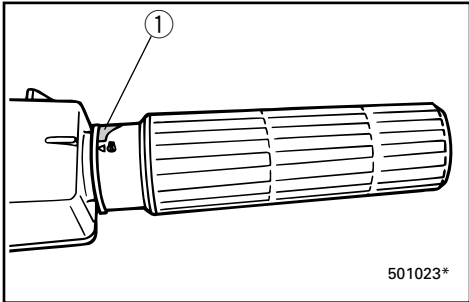

EMU00082

Throttle Indicator

The fuel consumption curve on the throttle indicator shows the relative amount of fuel consumed for each throttle position. Choose the setting that offers the best performance and fuel economy for the desired operation.

① Throttle indicator

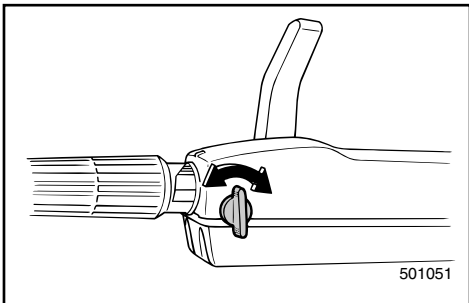

EMU01157

Throttle Friction Adjusting Knob

A friction device in the tiller handle provides adjustable resistance to movement of the throttle grip, and can be set according to operator preference.

Resistance	Knob
Increase	Turn clockwise
Decrease	Turn counterclockwise

When constant speed is desired, tighten the adjusting knob to maintain the desired throttle setting.

⚠WARNING

Do not overtighten the friction adjusting knob. If there is too much resistance, it may be difficult to move the throttle grip, which could result in an accident.

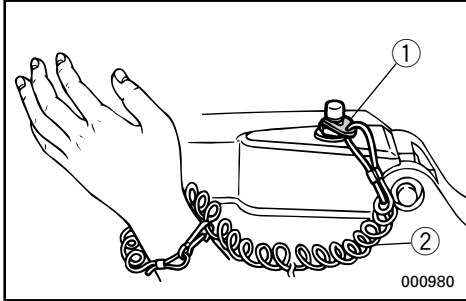

EMU00933

Engine Stop Lanyard Switch

The lock-plate ① must be attached to the engine stop lanyard switch for the engine to run. The lanyard ② should be attached to a secure place on the operator's clothing, or arm or leg. Should the operator fall overboard or leave the helm, the lanyard will pull out the lock plate, stopping ignition to the engine. This will prevent the boat from running away under power.

⚠WARNING

- Attach the lanyard to a secure place on your clothing, your arm or leg while operating.
- Do not attach the lanyard to clothing that could tear loose. Do not route the lanyard in such a way that it could become entangled, preventing it from functioning.
- Avoid accidentally pulling the lanyard during normal operation. Loss of engine power means the loss of most steering control. Also, without engine power, the boat could slow rapidly. This could cause people and objects in the boat to be thrown forward.

NOTE:

The engine cannot be started with the lock-plate removed.

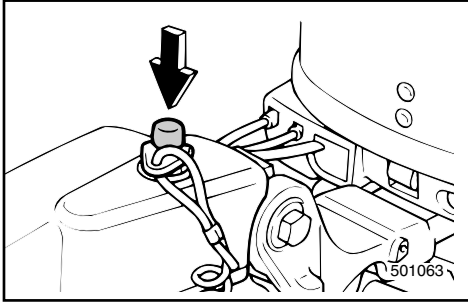

EMU00085

Engine Stop Button

Pushing this button opens the ignition circuit and stops the engine.

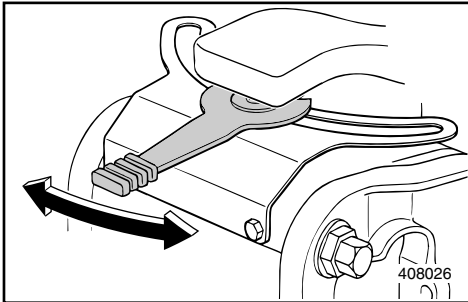

EMU01150

Steering Friction Adjusting Lever

A friction device provides adjustable resistance to the steering mechanism, and can be set according to operator preference. An adjusting lever is located on the bottom of the tiller handle bracket.

Resistance	Lever
Increase	Turn to the left
Decrease	Turn to the right

⚠ WARNING

Do not overtighten the friction adjusting lever. If there is too much resistance, it may be difficult to steer, which could result in an accident.

EMU00096

REMOTE CONTROL

Both the shifter and the throttle are actuated by the remote control lever. In addition, this control also has the electrical switches.

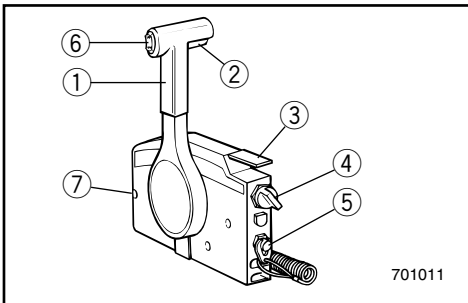

- ① Remote control lever
- ② Neutral interlock trigger
- ③ Neutral throttle lever
- ④ Main switch
- ⑤ Engine stop lanyard switch
- ⑥ Power trim/tilt switch
- ⑦ Throttle friction adjusting screw

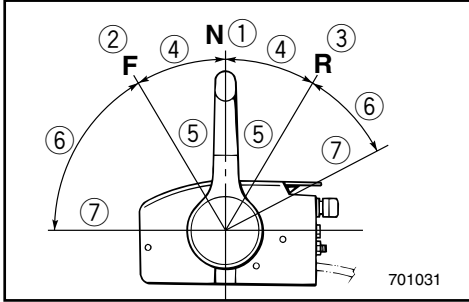

EMU00098

Remote Control Lever

Moving the lever forward from the Neutral position engages Forward gear. Pulling the lever back from Neutral engages Reverse. The engine will continue to run at idle until the lever is moved about 35° (a detent can be felt). Moving the lever farther opens the throttle, and the engine will begin to accelerate.

- ① Neutral
- ② Forward
- ③ Reverse
- ④ Shift
- ⑤ Fully closed
- ⑥ Throttle
- ⑦ Fully open

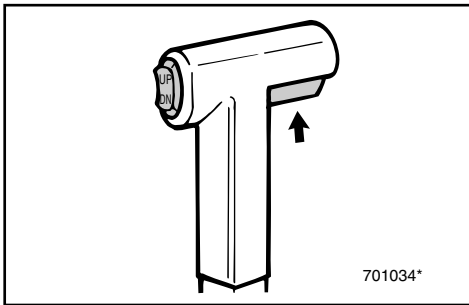

EMU00099

Neutral Interlock Trigger

To shift out of Neutral, the neutral interlock trigger of the remote control lever must first be pulled up.

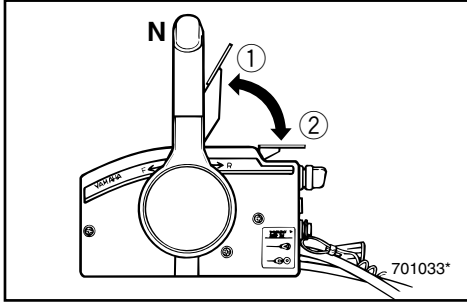

EMU00100

Neutral Throttle Lever

To open the throttle without shifting into either Forward or Reverse, place the remote control lever in the Neutral position and lift the neutral throttle lever.

NOTE:

The neutral throttle lever will operate only when the remote control lever is in Neutral. The remote control lever will operate only when the neutral throttle lever is in the closed position.

- ① Fully open
- ② Fully closed

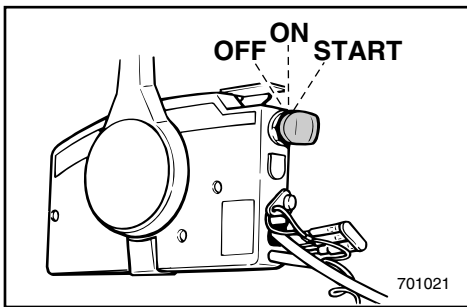

EMU00101

Main switch

The main switch controls the ignition system; its operation is described below.

● **OFF**

Electrical circuits switched off.
(The key can be removed.)

● **ON**

Electrical circuits switched on.
(The key cannot be removed.)

● **START**

Starter-motor will turn and start engine.
(When the key is released, it returns automatically to "ON".)

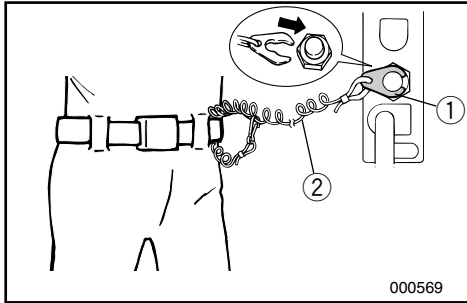

EMU00934

Engine Stop Lanyard Switch

The lock-plate ① must be attached to the engine stop lanyard switch for the engine to run. The lanyard ② should be attached to a secure place on the operator's clothing, or arm or leg. Should the operator fall overboard or leave the helm, the lanyard will pull out the lock plate, stopping ignition to the engine. This will prevent the boat from running away under power.

⚠WARNING

- Attach the lanyard to a secure place on your clothing, your arm or leg while operating.
- Do not attach the lanyard to clothing that could tear loose. Do not route the lanyard in such a way that it could become entangled, preventing it from functioning.
- Avoid accidentally pulling the lanyard during normal operation. Loss of engine power means the loss of most steering control. Also, without engine power, the boat could slow rapidly. This could cause people and objects in the boat to be thrown forward.

NOTE:

The engine cannot be started with the lock-plate removed.

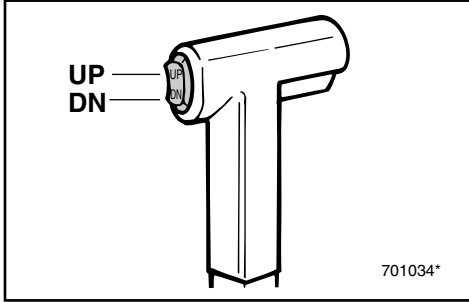

EMU01331

Power Trim/Tilt Switch

The power trim/tilt adjusts the motor angle in relation to the transom. The power trim/tilt switch is located on the remote control lever grip. Pushing the switch “UP” trims the motor up, then tilts the motor up. Pressing the switch “DN” tilts the motor down and trims the motor down. When the switch button is released, the motor will stop in its current position.

NOTE: _____

Refer to the sections “ADJUSTING TRIM ANGLE” and “TILTING UP/DOWN” in Chapter 3 for instructions on usage.

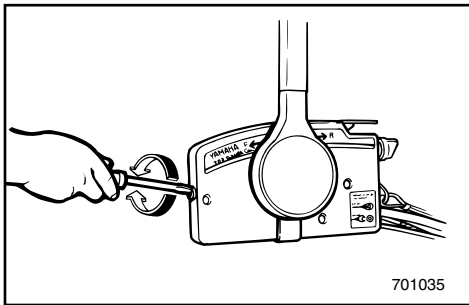

EMU01155

Throttle Friction Adjusting Screw

A friction device in the remote control box provides adjustable resistance to movement of the remote control lever, and can be set according to operator preference. An adjusting screw is located on the front of the remote control box.

Resistance	Screw
Increase	Turn clockwise
Decrease	Turn counterclockwise

⚠ WARNING _____

Do not overtighten the friction adjusting screw. If there is too much resistance, it may be difficult to move the lever, which could result in an accident.



EM00113

TRIM TAB

The trim tab should be adjusted so that the steering control can be turned to either the right or left by applying the same amount of force.

⚠WARNING

An improperly adjusted trim tab may cause difficult steering. Always test run after the trim tab has been installed or replaced to be sure steering is correct. Be sure you have tightened the bolt after adjusting the trim tab.

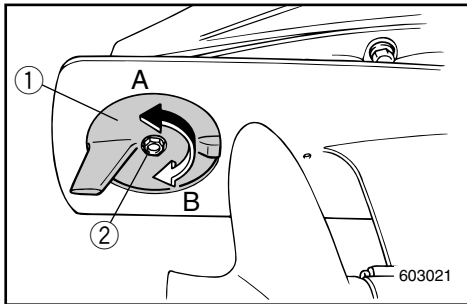

- ① Trim tab
- ② Bolt

Boat tends to veer	The fin of trim tab
To the left (port side)	Turn to the left (A in the figure)
To the right (starboard side)	Turn to the right (B in the figure)

CAUTION:

The trim tab also serves as an anode to protect the engine from electrochemical corrosion. Never paint the trim tab as it will become ineffective as an anode.

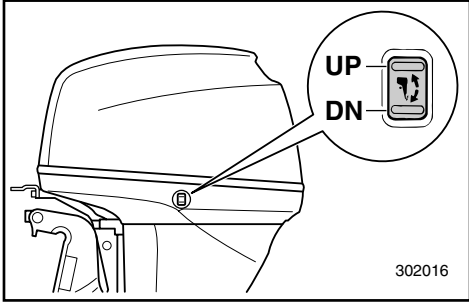

302016

EMU01125

POWER TRIM/TILT SWITCH

The power trim/tilt adjusts the motor angle in relation to the transom. The power trim/tilt switch is located on the side of the bottom engine cowling. Pushing the switch "UP" trims the motor up, then tilts the motor up. Pressing the switch "DN" tilts the motor down and trims the motor down. When the switch button is released, the motor will stop in its current position.

⚠ WARNING

Use the power trim/tilt switch located on the bottom engine cowling only when the boat is at a complete stop with the engine off. Attempting to use the cowling-mounted power trim/tilt switch while the boat is moving could increase the risk of falling overboard and could distract the operator, increasing the risk of collision with another boat or an obstacle.

NOTE:

Refer to the section "Adjusting Trim Angle" and "Tilting Up/Down" for instructions on usage.

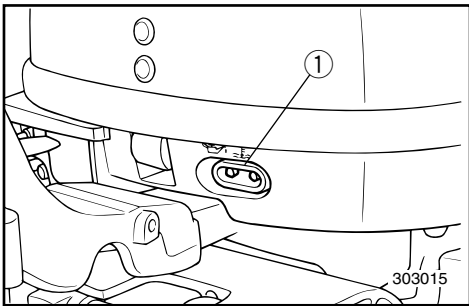

303015

EMU01128

WARNING INDICATOR(S)

If the engine develops a condition monitored by the warning system, an indicator will come on.

Refer to the "WARNING SYSTEM" section for details.

- ① Warning indicator(s)

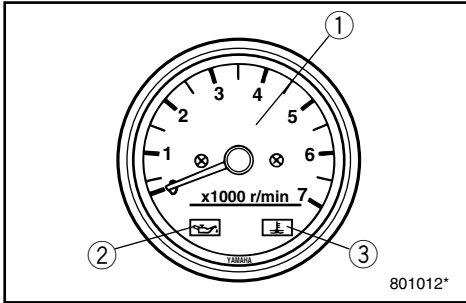

EMU00125

TACHOMETER

This meter contains the following functions,

- ① Tachometer
- ② Low oil pressure warning lamp
- ③ Overheat warning lamp

EMU00126

Tachometer

This meter shows the engine speed.

EMU00127

Low Oil Pressure Warning Lamp

If oil pressure drops too low, this lamp will flash.

EMU01365

Overheat Warning Lamp

If the engine temperature rises too high, this lamp will flash.

CAUTION: _____

Do not continue to run the engine if the low oil pressure lamp or the overheat warning lamp is "ON". Serious engine damage may occur.

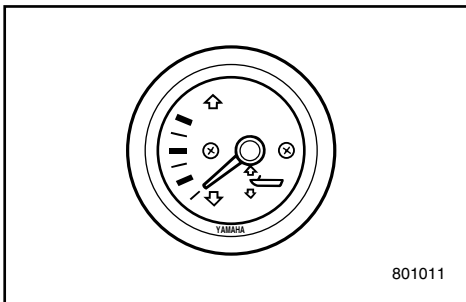

EMU00132

TRIM METER (for Power trim/tilt model)

This meter shows the trim angle of your outboard.

NOTE: _____

Memorize the trim angles that work best for your boat under different conditions. Adjust the trim angle to the desired setting by operating the power trim/tilt switch.

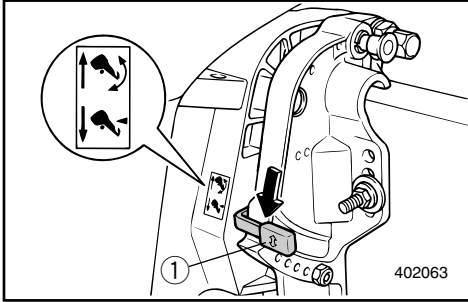

EMU00154

TILT LOCK MECHANISM (for Hydro-tilt model)

Tilt-lock mechanism is used to prevent reverse thrust from the propeller lifting the outboard motor when reversing. To lock it, set the tilt-lock lever in the Lock position. To release it, place the tilt-lock lever in the Tilt position.

① Tilt-lock lever

NOTE:

The tilt-lock mechanism on the hydro-tilt model can be used to keep the outboard motor at a slightly tilted angle for shallow water cruising. Refer to CRUISING IN SHALLOW WATER for the correct operation.

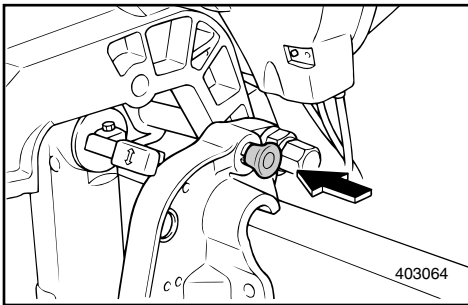

EMU00155

TILT SUPPORT KNOB

To keep the outboard motor in the tilted-up position, push the tilt support knob under the swivel bracket.

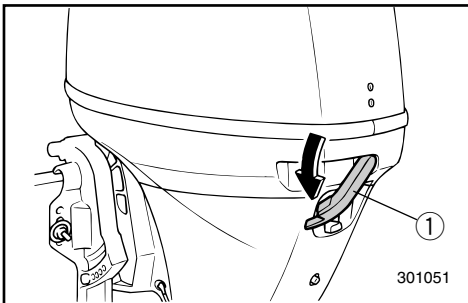

EMU00162

TOP COWLING LOCK LEVER

To remove the engine top cowling, turn the lock lever. Then lift off the cowling. When replacing the cowling, check to be sure it fits properly in the rubber seal. Then lock the cowling again by moving the lever upward.

① Top cowling lock lever

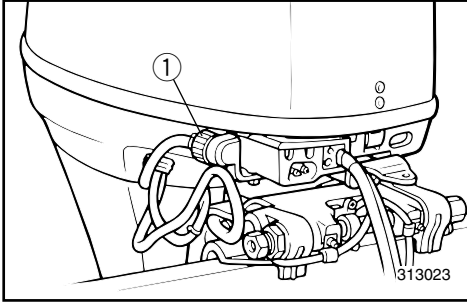

EMU01146

FLUSHING DEVICE

This device ① is used to clean the cooling water passages of the motor using a garden hose and tap water.

NOTE:

Refer to "Cleaning Cooling-water Passages" in Chapter 4 for instructions on usage.



EMU00169

WARNING SYSTEM

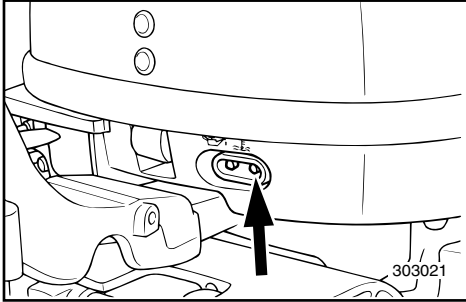

CAUTION:

Do not continue to operate the engine if the warning device has activated. Consult your Yamaha dealer if the problem cannot be located and corrected.

EMU00170

OVERHEAT WARNING

This engine has an overheat warning device. If the engine temperature rises too high, the warning device will activate.

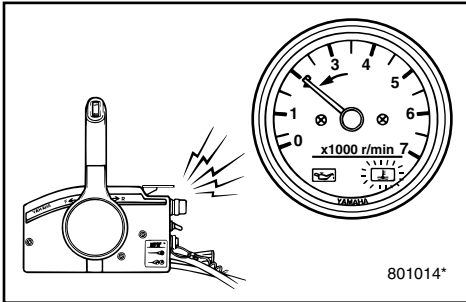

(○); Included (—); N/A

Activation of warning device	Tiller control model	Remote control model
The engine speed will automatically decrease to about 2,000 r/min.	○	○
The overheat warning indicator will come on.	○	○
The buzzer will sound.	—	○

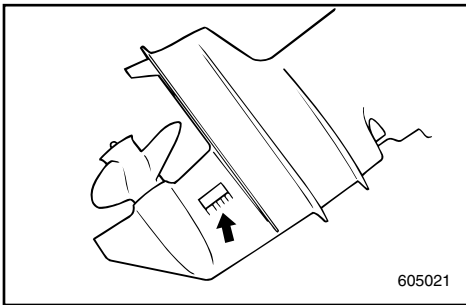

If the warning system has been activated, stop the engine and check the water inlet for clogging.

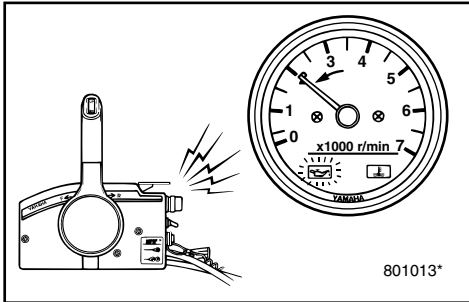
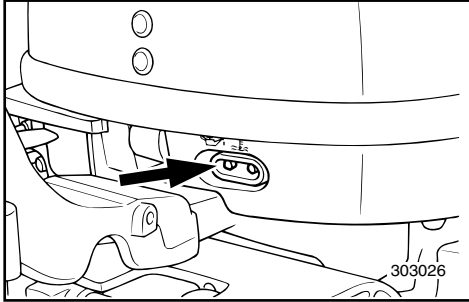

EMU00173

LOW OIL PRESSURE WARNING

If oil pressure drops too low, the warning device will activate.

(○):Included (—):N/A

Activation of warning device	Tiller control model	Remote control model
Engine speed will automatically decrease to about 2,000 r/min.	○	○
The low oil pressure warning indicator will come on.	○	○
The buzzer will sound.	—	○

If the warning system has been activated, stop the engine as soon as it is safe to do so. Check oil level and add oil as needed. If the oil level is correct, consult your Yamaha dealer.

CAUTION:

Do not continue to run the engine if the low oil pressure lamp is "ON". Serious engine damage may occur.



- MEMO -



EMU00174

Chapter 3

OPERATION

INSTALLATION	3-1
Mounting the outboard motor	3-2
BREAKING IN (RUNNING IN) ENGINE	3-4
PRE-OPERATION CHECKS	3-5
CHECKING THE ENGINE OIL LEVEL	3-6
FILLING FUEL	3-7
STARTING ENGINE	3-8
WARMING UP ENGINE	3-12
SHIFTING	3-13
Forward	3-13
Reverse	3-14
STOPPING ENGINE	3-15
TRIMMING OUTBOARD MOTOR	3-16
Adjusting trim angle	3-17
TILTING UP/DOWN	3-20
CRUISING IN SHALLOW WATER	3-23
CRUISING IN OTHER CONDITIONS	3-24
Cruising in salt water	3-24
Cruising in turbid water	3-24



EMU00175

INSTALLATION

CAUTION: _____

Incorrect engine height or obstructions to smooth water flow (such as the design or condition of the boat or accessories such as transom ladders/depth finder transducers) can create airborne water spray while the boat is cruising. Severe engine damage may result if the motor is operated continuously in the presence of airborne water spray.

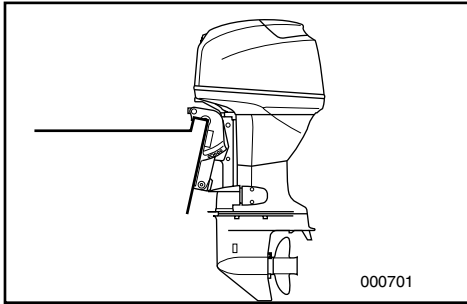

NOTE: _____

During water testing check the buoyancy of the boat, at rest, with its maximum load. Check that the static water level on the exhaust housing is low enough to prevent water entry into the powerhead, when water rises due to waves when the outboard is not running.



EMU00176

MOUNTING THE OUTBOARD MOTOR

⚠WARNING

Improper mounting of the outboard motor could result in hazardous conditions such as poor handling, loss of control, or fire hazards. Observe the following:

- The information presented in this section is intended as reference only. It is not possible to provide complete instructions for every possible boat/motor combination. Proper mounting depends in part on experience and the specific boat/motor combination.
- Your dealer or other person experienced in proper rigging should mount the motor. If you are mounting the motor yourself, you should be trained by an experienced person. [permanent mounted type]
- Your dealer or other person experienced in proper outboard motor mounting should show you how to mount your motor. [portable type]

Mount the outboard motor on the center line (keel line) of the boat, and ensure that the boat itself is well balanced. Otherwise, the boat will be hard to steer. For boats without a keel or which are asymmetrical, consult your dealer.

- ① Center line (keel line)

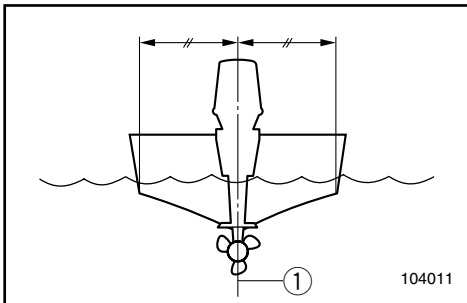

**⚠ WARNING**

Overpowering a boat may cause severe instability. Do not install an outboard motor with more horsepower than the maximum rating on the capacity plate of the boat. If the boat does not have a capacity plate, consult the boat manufacturer.

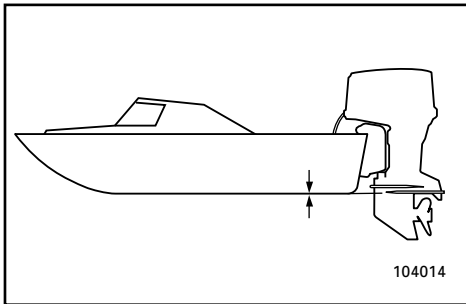

EMU01299

Mounting Height

To run your boat at optimum efficiency, the water-resistance (drag) of the boat and outboard motor must be made as little as possible. The mounting-height of the outboard motor greatly affects the water-resistance. If the mounting-height is too high, cavitation tends to occur, thus reducing the propulsion; and if the propeller tips cut the air, the engine speed will rise abnormally and cause the engine to overheat. If the mounting-height is too low, the water-resistance will increase and thereby reduce engine efficiency. Mount the engine so that the anti-cavitation plate is in alignment with the bottom of the boat .

NOTE:

- The optimum mounting height of the outboard motor is affected by the boat/motor combination. Test runs at different heights can help determine the optimum mounting height.
- Refer to the section "TRIMMING OUTBOARD MOTOR" for instructions on setting the trim angle of the outboard.



EMU00224

BREAKING IN (RUNNING IN) ENGINE

Your new engine requires a period of break-in (running-in) to allow mating surfaces of moving parts to wear-in evenly. Correct break-in (running-in) will help ensure proper performance and longer engine life.

CAUTION: _____

Failure to follow the break-in (running-in) procedure may result in reduced engine life or even severe engine damage.

Break-in (running-in) time: 10 hours

EMU00233

Run the engine under load (in gear with a propeller installed) as follows.

- 1) For the first hour of operation:
Run the engine at 2,000 r/min or at approximately half throttle.
- 2) For the second hour of operation:
Run the engine at 3,000 r/min or at approximately three-quarter throttle, and during this period run it at full throttle for approximately one minute every ten minutes.
- 3) For the next eight hours of operation:
Avoid continuous operation at full throttle for more than five minutes at a time.
- 4) After these first 10 hours:
Operate the engine normally.



EMU00204

PRE-OPERATION CHECKS

⚠ WARNING

If any item in the pre-operation check is not working properly, have it inspected and repaired before operating the out-board motor. Otherwise, an accident could occur.

CAUTION:

Do not start the engine out of water. Overheating and serious engine damage can occur.

EMU00206

Fuel

- Check to be sure you have plenty of fuel for your trip.
- Make sure there are no fuel leaks or gasoline fumes.
- Check fuel line connections to be sure they are tight.
- Be sure the fuel tank is positioned on a secure, flat surface, and that the fuel hose is not twisted or flattened, or likely to contact sharp objects.

EMU00208

Oil

- Check the level of the oil in the sump with the dipstick. If necessary, add oil to bring the level up to the upper mark.



EMU00209

Controls

- Check throttle, shift, and steering for proper operation before starting the engine.
- The controls should work smoothly, without binding or unusual free play.
- Look for loose or damaged connections.
- Check operation of the starter and stop switches when the outboard motor is in the water.

EMU00210

Engine

- Check the engine and engine mounting.
- Look for loose or damaged fasteners.
- Check the propeller for damage.

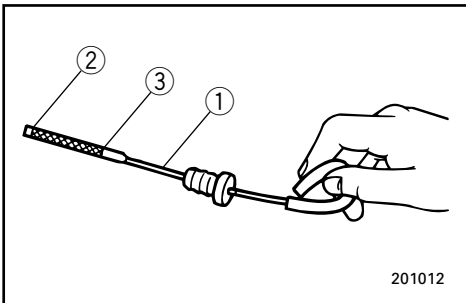
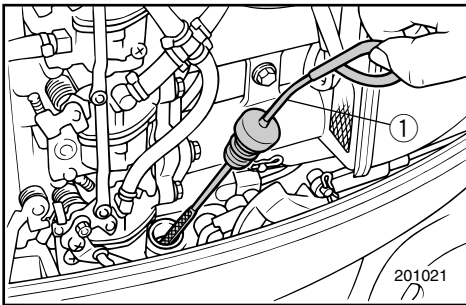

EMU01436

CHECKING THE ENGINE OIL LEVEL

- 1) Put the outboard motor in an upright position (not tilted).
- 2) Pull out the oil dipstick and wipe it clean.
- 3) Completely re-insert the dipstick and pull out it again.
- 4) Check the oil level using the dipstick to be sure the level falls between the upper and lower marks. Fill with oil if it is below the lower mark, or drain to the specified level if it is above the upper mark.

- ① Oil dipstick
- ② Lower level mark
- ③ Upper level mark



EMU01031

FILLING FUEL

- 1) Remove the fuel tank cap.
- 2) Fill the fuel tank carefully.
- 3) Close the cap securely after refueling.
Wipe up any spilled fuel.

EMU00203

Ring Free Fuel Additive

Gasoline is a precise blend of many different substances, each chosen to give certain characteristics. Gasoline blends have been changing in recent years in response to concerns about pollution and resulting emissions regulations. One of the most obvious changes has been the elimination of lead from most fuels.

As gasoline has changed, the amount of additives such as aromatics and oxygenates has increased. These additives are important for the engines in passenger cars, but they can have detrimental effects in marine engines, because of increased deposits in the combustion chamber. When enough deposits collect, piston rings begin sticking. Performance drops and engine wear increases dramatically.

While many additives available may reduce deposits, Yamaha recommends the use of **Ring Free Fuel Additive**, available from your Yamaha dealer. Ring Free has repeatedly proven its ability to clean combustion deposits from inside the engine, notably the critical piston-ring-land area, and fuel system components. Follow product labeling for use instructions.



EMU01147

STARTING ENGINE

▲WARNING

- Before starting the engine, make sure that the boat is tightly moored and that you can steer clear of any obstructions. Be sure there are no swimmers in the water near you.
- When the air vent screw is loosened, gasoline (petrol) vapor will be released. Gasoline (petrol) is highly flammable, and its vapors are flammable and explosive. Refrain from smoking, and keep away from open flames and sparks while loosening the air vent screw.
- This product emits exhaust gases which contain carbon monoxide, a colorless, odorless gas which may cause brain damage or death when inhaled. Symptoms include nausea, dizziness, and drowsiness. Keep cockpit and cabin areas well ventilated. Avoid blocking exhaust outlets.

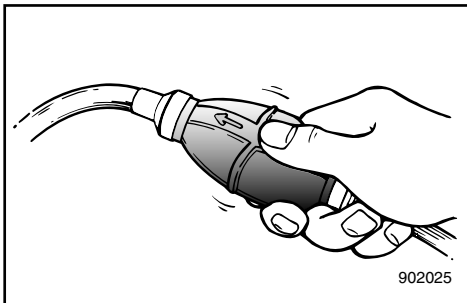
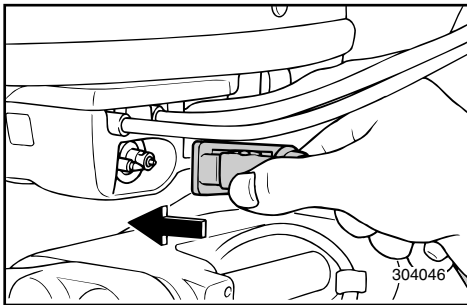

- 1) If there is an air vent screw on the fuel tank cap, loosen it 2 or 3 turns.
- 2) If there is a fuel joint on the motor, firmly connect the fuel line to the joint. Then firmly connect the other end of the fuel line to the joint on the fuel tank.

NOTE:

During engine operation place the tank horizontally, or fuel cannot be drawn into the engine.

- 3) Squeeze the primer bulb with the outlet end up until you feel it become firm.

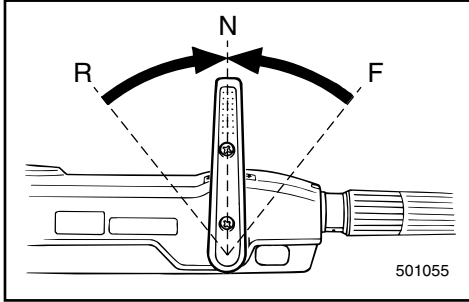

EMU01497

PROCEDURE FOR TILLER CONTROL MODEL

4) Place the gear-shift lever in the neutral position.

NOTE: _____

The start-in-gear protection device prevents the engine from starting except when in Neutral.

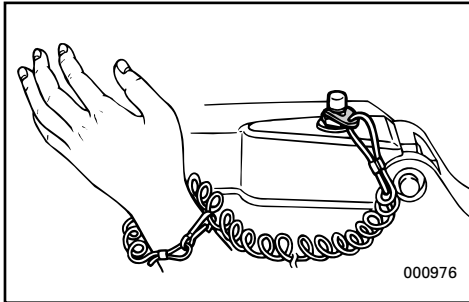

5) Attach the engine stop switch lanyard to a secure place on your clothing, or your arm or leg. Then, install the lock plate on the other end of the lanyard in the engine stop switch.

⚠ WARNING _____

- Attach the engine stop switch lanyard to a secure place on your clothing, your arm or leg while operating.
- Do not attach the lanyard to clothing that could tear loose. Do not route the lanyard where it could become entangled, preventing it from functioning.
- Avoid accidentally pulling the lanyard during normal operation. Loss of engine power means the loss of most steering control. Also, without engine power, the boat could slow rapidly. This could cause people and objects in the boat to be thrown forward.

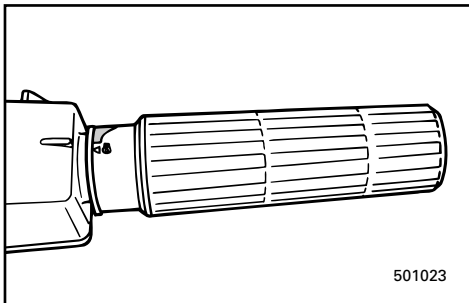

6) Place the throttle control grip in the "START" position.

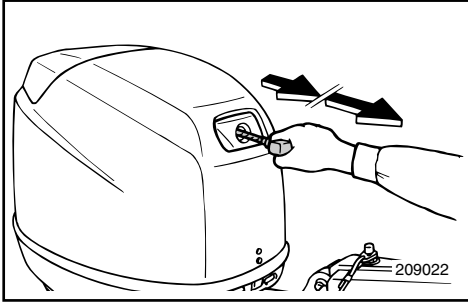

EMU01005

Manual Start Model

- 7) Pull the starter handle slowly until you feel resistance. Then, give a strong pull straight out to crank and start the engine. Repeat it, if necessary.

NOTE: _____

If the warm engine fails to start, open the throttle slightly and try to start the engine.

- 8) After the engine starts, return the starter handle slowly to the original position before releasing it.

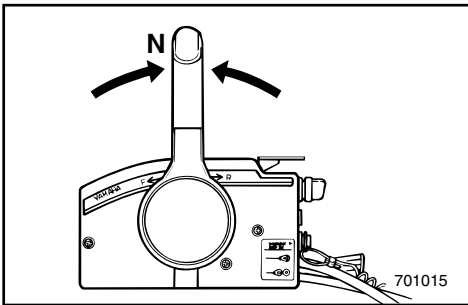

EMU00247

PROCEDURE FOR REMOTE CONTROL MODEL

- 4) Place the remote control lever in the Neutral position.

NOTE: _____

The start-in-gear protection device prevents the engine from starting except when in Neutral.

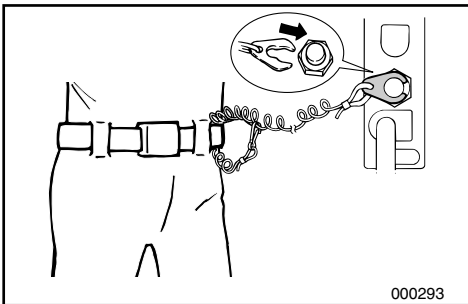

- 5) Attach the engine stop switch lanyard to a secure place on your clothing, or your arm or leg. Then, install the lock plate on the other end of the lanyard in the engine stop switch.

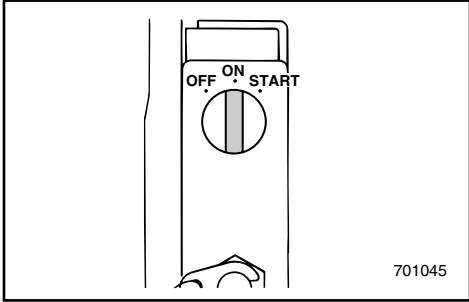

WARNING

- Attach the engine stop switch lanyard to a secure place on your clothing, your arm or leg while operating.
- Do not attach the lanyard to clothing that could tear loose. Do not route the lanyard where it could become entangled, preventing from functioning.
- Avoid accidentally pulling the lanyard during normal operation. Loss of engine power means the loss of most steering control. Also, without engine power, the boat could slow rapidly. This could cause people and objects in the boat to be thrown forward.

6) Turn the main switch to "ON".

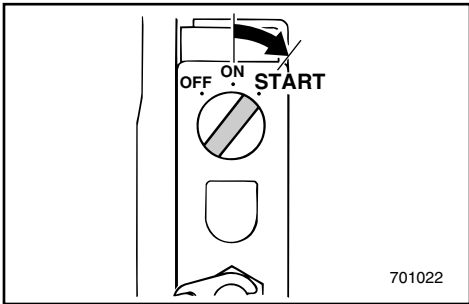

EMU00949

Electric Start Model

- 7) Turn the main switch to "START", and hold it for a maximum of 5 seconds.
- 8) Immediately after the engine starts, release the main switch to return it to "ON".

CAUTION:

- Do not turn the main switch to "START" when the engine is running.
- Do not keep the starter-motor turning for more than 5 seconds. The battery will rapidly become exhausted and it will be impossible for it to start the engine. If the engine does not start within 5 seconds, return the main switch to "ON", wait 10 seconds, and then crank the engine again.

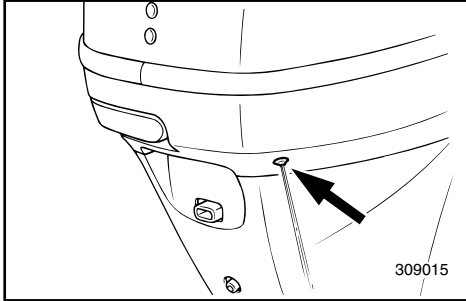

EMU00258

WARMING UP ENGINE

- 1) Before beginning operation, allow the engine to warm up at idling speed for 3 minutes. (Failure to do this will shorten engine life.)
- 2) Be sure the low oil pressure warning indicator goes off after starting the engine.
- 3) Check for a steady flow of water from the cooling-water pilot hole.

CAUTION:

- If the low oil pressure indicator does not go off after the engine starts, stop the engine. Otherwise, serious engine damage could occur. Check the oil level and add oil if necessary. If the cause for the low oil pressure warning indicator cannot be found, consult your Yamaha dealer.
- A continuous flow of water from the pilot hole shows that the water pump is pumping water through the cooling passages. If water is not flowing out of the pilot hole at all times while the engine is running, do not continue to run the engine. Overheating and serious damage could occur. Stop the engine and check to see if the water inlet on the lower casing is blocked. If the problem cannot be found and corrected, consult your Yamaha dealer.



EMU00261

SHIFTING

⚠ WARNING

Before shifting, make sure there are no swimmers or obstacles in the water near you.

CAUTION:

To change the shifting position from forward to reverse or vice-versa, close the throttle first so that the engine idles (or runs at low speeds).

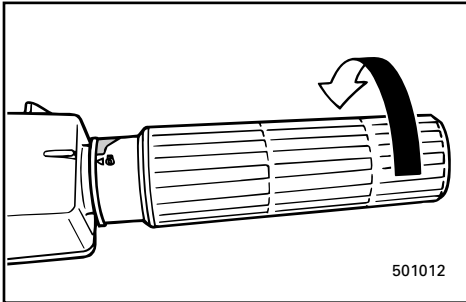

EMU00265

FORWARD

Tiller control model

- 1) Place the throttle control grip in the fully closed position.
- 2) Turn the gear-shift lever quickly and firmly from Neutral to Forward.

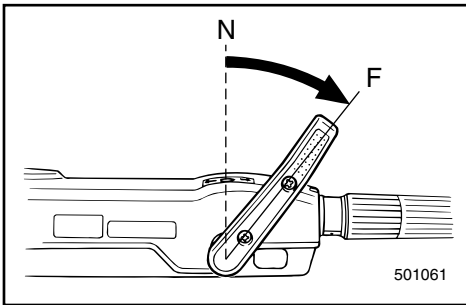

Remote control model

Pull up the neutral interlock trigger if equipped and move the remote control lever quickly and firmly from Neutral to Forward.

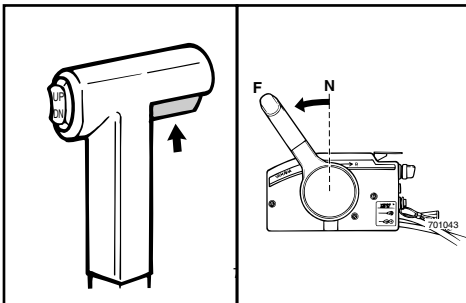

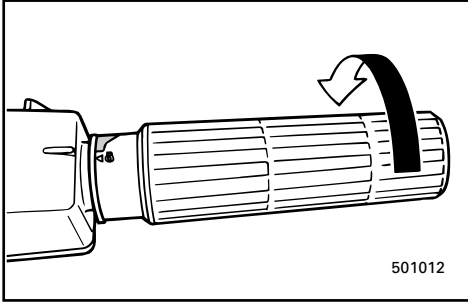

EMU01326

REVERSE

⚠️WARNING

When operating in Reverse, go slowly. Do not open the throttle more than half. Otherwise, the boat may become unstable, which could result in loss of control and an accident.

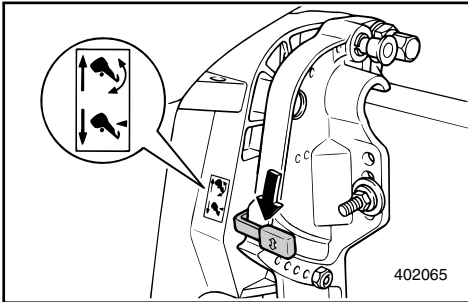

- 1) Place the throttle control grip in the fully closed position (for Tiller control model).
- 2) Check that the tilt-lock lever (for Manual tilt/Hydro-tilt model) is in the locked position.

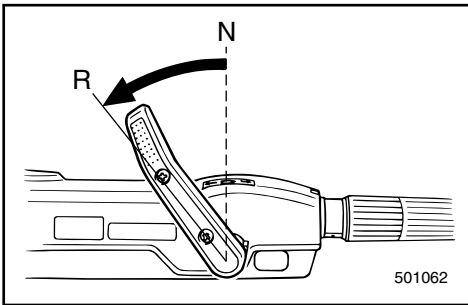

Tiller control model

- 3) Turn the gear-shift lever quickly and firmly from Neutral to Reverse.

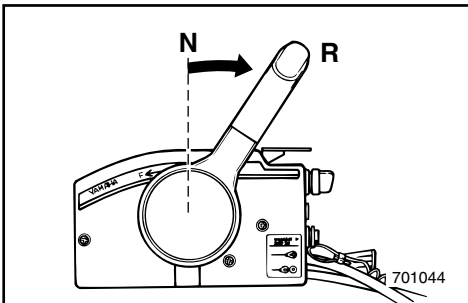

Remote control model

- 3) Pull up the neutral interlock trigger if equipped and move the remote control lever quickly and firmly from Neutral to Reverse.

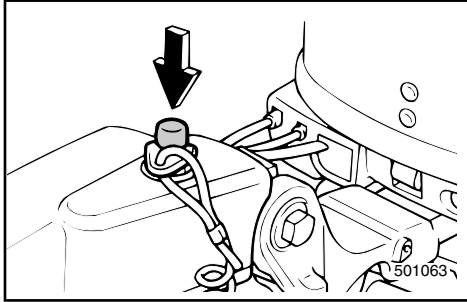

EMU00273

STOPPING ENGINE

Let it cool off for a few minutes at idle or low speed first. Stopping the engine immediately after operating at high speed is not recommended.

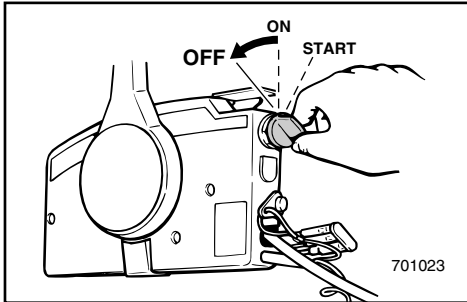

EMU00277

1) Push and hold the engine stop button or turn the main switch to "OFF".

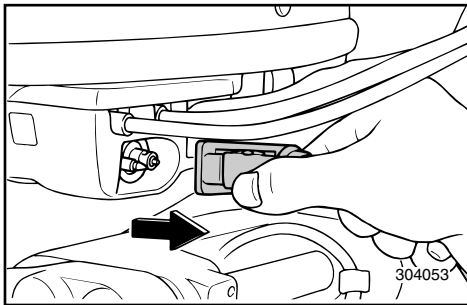

- 2) If the fuel joints are provided, disconnect the fuel line from the motor after stopping the engine.
- 3) Tighten the air vent screw on the fuel tank cap after stopping the engine, if it is equipped.
- 4) Remove the key if the boat will be left unattended.

NOTE: _____

The engine can also be stopped by pulling the lanyard and removing the lock plate from the engine stop lanyard switch (then turning the main switch to "OFF").



EMU01412

TRIMMING OUTBOARD MOTOR

The trim angle of the outboard motor helps determine the position of the bow of the boat in the water. The correct trim angle will help improve performance and fuel economy while reducing strain on the engine. The correct trim angle depends upon the combination of boat, engine, and propeller. Correct trim is also affected by variables such as the load in the boat, sea conditions, and running speed.

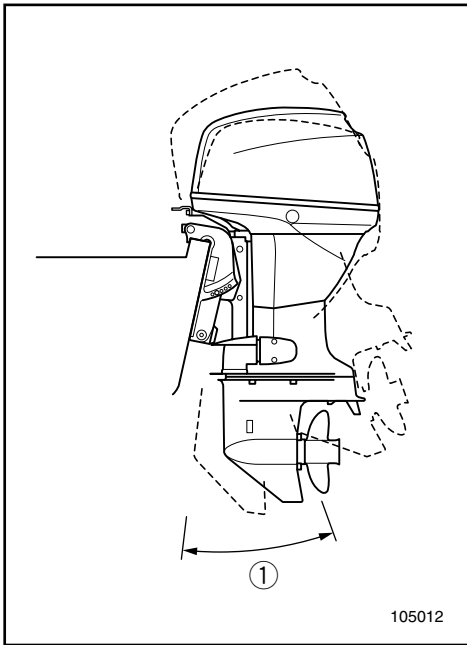

⚠ WARNING

Excessive trim for the operating conditions (either trim up or trim down) can cause boat instability and can make steering the boat more difficult. This increases the possibility of an accident. If the boat begins to feel unstable or is hard to steer, slow down and/or readjust the trim angle.

NOTE:

Refer to the section "ADJUSTING TRIM ANGLE" for instructions on usage.

① Trim operating angle



ADJUSTING TRIM ANGLE

EMU01113*

Hydro-tilt Model

⚠ WARNING

- Stop the engine before adjusting the trim angle.
- Be sure all people are clear of the outboard motor when adjusting the tilt angle, also be careful not to pinch any body parts between the drive unit and clamp bracket.
- Use caution when trying a trim position for the first time. Increase speed gradually and watch for any signs of instability or control problems. Improper trim angle can cause loss of control.

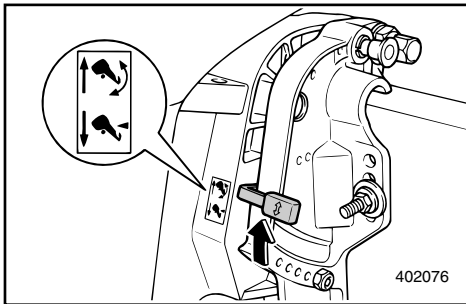

- 1) Stop the engine.
- 2) Place the tilt-lock lever in the release position.
- 3) Hold the rear of the top cowling with one hand and tilt the engine to the desired angle.
- 4) Place the tilt-lock lever back into the lock position to support the engine.

To raise the bow ("trim-out"), tilt the engine up.

To lower the bow ("trim-in"), tilt the engine down.

Make test runs with the trim set to different angles to find the position that works best for your boat and operating conditions.



EMU01116*

Power Trim/Tilt Model

⚠ WARNING

- Be sure all people are clear of the outboard motor when adjusting the trim/tilt angle, also be careful not to pinch any body parts between the drive unit and clamp bracket.
- Use caution when trying a trim position for the first time. Increase speed gradually and watch for any signs of instability or control problems.

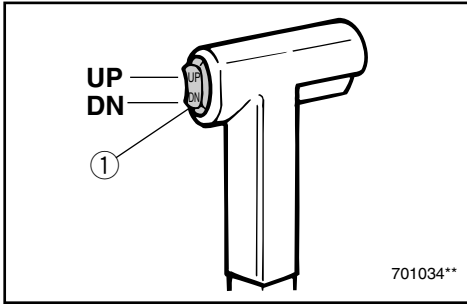

The outboard motor trim angle can be adjusted operating the power trim/tilt switch ①.

To raise the bow ("trim-out"), push the switch UP.

To lower the bow ("trim-in"), push the switch DN.

Make test runs with the trim set to different angles to find the position that works best for your boat and operating conditions.

NOTE:

To adjust the trim angle while the boat is moving, use the power trim and tilt switch located on the remote control device or tiller handle, if so equipped.



EMU00282

Bow Up

When the boat is on plane, a bow-up attitude result in less drag, greater stability and efficiency. This is generally when the keel line of the boat is up about 3 to 5 degrees. When trimmed out, the boat may have more tendency to steer to one side or the other. Compensate for this as you steer. The trim tab can also be adjusted to help offset this effect.

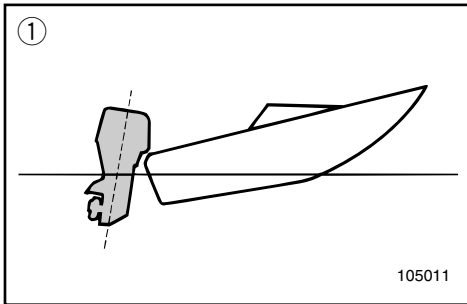

Too much trim-out puts the bow of the boat too high in the water. Performance and economy are decreased because the hull of the boat is pushing the water and there is more air drag.

Excessive trim-up can cause the propeller to ventilate, which reduces performance further. When trimmed-out too much, a boat may “porpoise” (hop in the water), which could throw the operator and passengers overboard.

EMU00283

Bow Down

When the bow of the boat is down, it is easier to accelerate from a standing start onto plane.

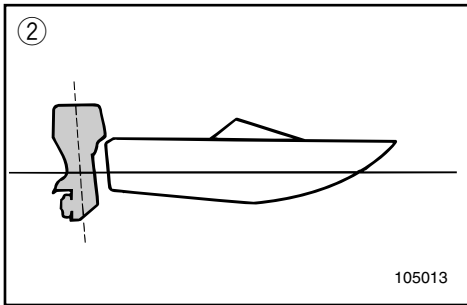

Too much trim-in causes the boat to “plow” through the water, decreasing fuel economy and making in hard to increase speed.

Operating with excessive trim-in at higher speeds also makes the boat unstable. Resistance at the bow is greatly increased, heightening the danger of “bow steering” and making operation difficult and dangerous.

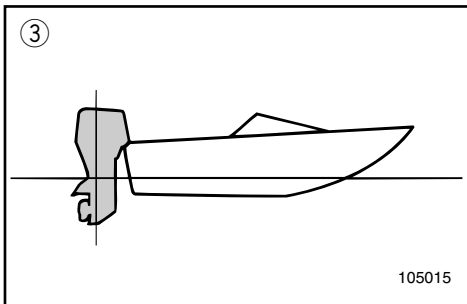

- ① Bow up
- ② Bow down
- ③ Optimum angle



EMU00285

TILTING UP/DOWN

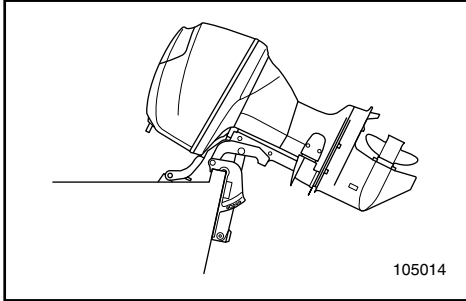

If the engine will be stopped for some time, or if the boat is moored in shallows, the engine should be tilted up to protect the propeller and casing from damage by collision with obstructions, and also to reduce salt corrosion.

CAUTION:

- Before tilting the motor, follow the procedures under "STOPPING ENGINE". Never tilt the motor while the engine is running. Severe damage from overheating can result.
- Do not tilt up the engine by pushing the steering handle as this could break the handle.

⚠ WARNING

Be sure all people are clear of the outboard motor when adjusting the tilt angle, also be careful not to pinch any body parts between the drive unit and engine bracket.

⚠ WARNING

Leaking fuel is a fire hazard. Disconnect the fuel line if the engine will be tilted for more than a few minutes. Otherwise, fuel may leak. (If the fuel connector is provided on the motor.)



EMU01127

PROCEDURE FOR TILTING UP
Hydro-tilt model

- 1) Remove the fuel-line connection from the motor.

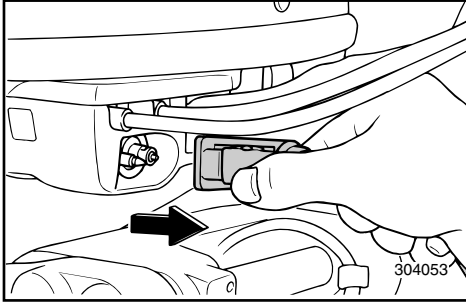

- 2) Place the tilt-lock lever in the release position.

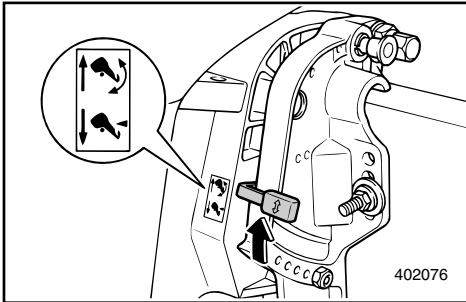

- 3) Hold the rear of the top cowling with one hand, tilt the engine up, push the tilt support knob into the clamp bracket, and place the tilt-lock lever back into the lock position to support the engine.

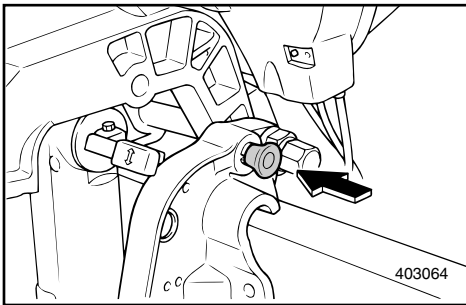

EMU01327

PROCEDURE FOR TILTING UP
Power trim/tilt model

- 1) Remove the fuel-line connection from the motor.

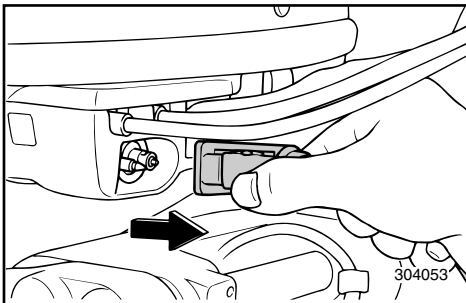

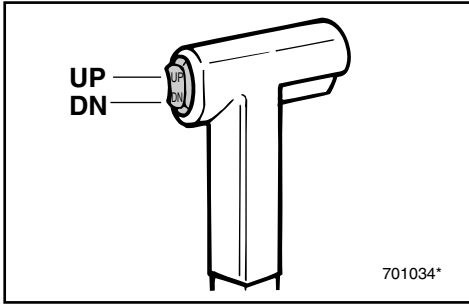

- 2) Push the power trim/tilt switch "UP" until the outboard has tilted up completely.

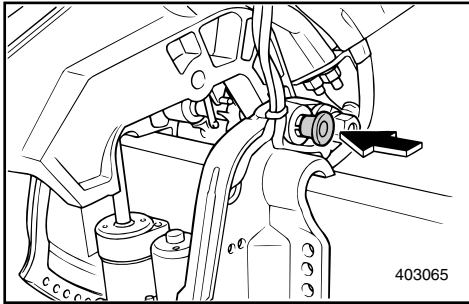

- 3) Push the tilt support knob into the clamp bracket to support the engine.

⚠ WARNING

After tilting the engine, be sure to support it with the tilt support knob. Otherwise, the engine could fall back down suddenly if oil in the power trim/tilt unit should lose pressure.

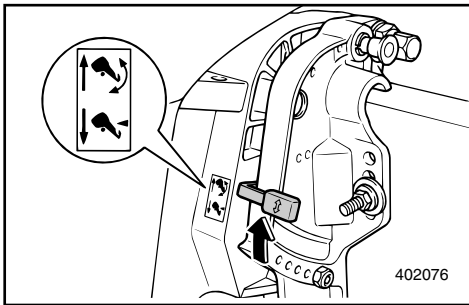

EMU01151

PROCEDURE FOR TILTING DOWN
Hydro-tilt model

- 1) Release the tilt-lock lever.
- 2) Hold the rear of the top cowling with one hand, tilt the engine up slightly and pull out the tilt support knob.
- 3) Slowly tilt the engine down.
- 4) Place the tilt-lock lever back into the lock position.

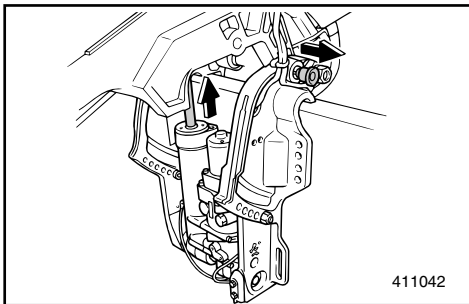

EMU01328

PROCEDURE FOR TILTING DOWN
Power trim/tilt model

- 1) Push the power trim/tilt switch "UP" until the engine is supported by the tilt rod.
- 2) Pull out the tilt support knob.
- 3) Push the power trim/tilt switch "DN" (Down) to lower the engine to the desired position.



EMU00307

CRUISING IN SHALLOW WATER

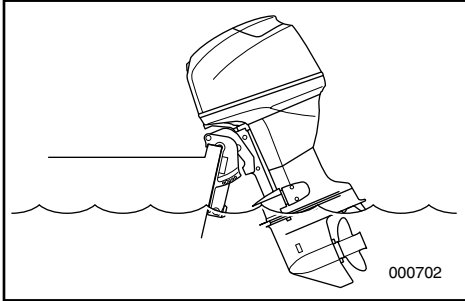

Hydro tilt model

The engine can be tilted up partially to allow operation in shallow water.

⚠ WARNING

- Place the gear shift in the Neutral position before setting for the shallow water cruising.
- Return the engine to its normal position as soon as the boat is back in deeper water.

CAUTION:

Do not tilt up the outboard motor so that the cooling water inlet of the lower unit is above the surface of the water when setting for and cruising in shallow water. Otherwise severe damage from overheating can result.

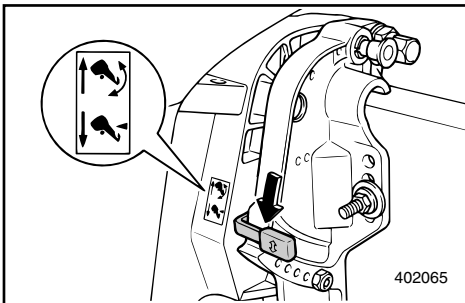
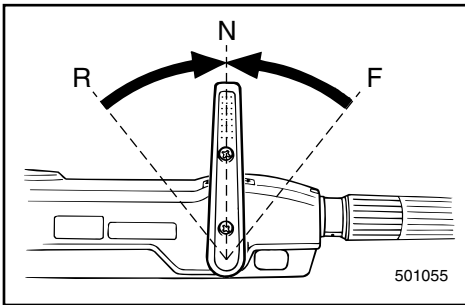

EMU00315

PROCEDURE

- 1) Place the gear in the neutral position.
- 2) Pull the tilt-lock lever up to the Tilt position.
- 3) Slightly tilt up the engine to the desired position and push the tilt-lock lever down to the Lock position.
- 4) To return the engine to the normal position, pull the tilt-lock lever up to the Tilt position and slowly tilt the engine down.
- 5) Push the tilt-lock lever down to the Lock position.



EMU00316

CRUISING IN OTHER CONDITIONS

CRUISING IN SALT WATER

After operating in salt water, wash out the cooling-water passages with fresh water to prevent them from becoming clogged-up with salt deposits.

NOTE: _____

Refer to cooling system flushing instructions in "TRANSPORTING AND STORING OUTBOARD MOTOR".

CRUISING IN TURBID WATER

It is strongly recommended that the optional chromium-plated water-pump kit be installed if the outboard is to be used in turbid (muddy) water conditions.



- MEMO -

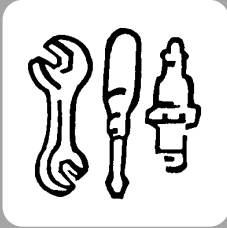

EMU00317

Chapter 4

MAINTENANCE

SPECIFICATIONS4-1

TRANSPORTING AND STORING

OUTBOARD MOTOR4-3

Trailing outboard motor4-3

Storing outboard motor4-4

PERIODIC MAINTENANCE.....4-9

Replacement parts4-9

Maintenance chart4-10

Greasing.....4-11

Cleaning and adjusting spark plug ...4-12

Checking fuel system4-14

Inspecting fuel filter4-15

Adjusting idling speed4-16

Changing engine oil.....4-17

Checking timing belt.....4-19

Replacing fuse4-20

Checking wiring and connectors.....4-20

Exhaust leakage4-20

Water leakage.....4-20

Checking power trim and tilt system4-21

Checking propeller.....4-22

Changing gear oil.....4-24

Inspecting and replacing anode(s)....4-25

Checking battery4-26

Checking bolts and nuts.....4-29

Cleaning cooling-water passages4-30

Motor exterior4-30

Coating the boat bottom4-30

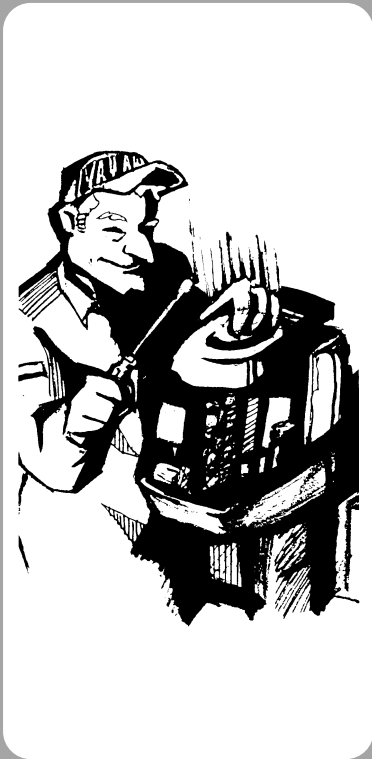



EMU00322*

SPECIFICATIONS

Item	Model	Unit	F30TRB
DIMENSIONS			
Overall Length		mm (in.)	700 (27.6)
Overall Width		mm (in.)	378 (14.9)
Overall Height	S/L/X	mm (in.)	—/1,340 (52.8)/ —
Transom height	S/L/X	mm (in.)	—/533 (21.0)/ —
Weight	S/L/X	kg (lb.)	—/91 (200)/ —
PERFORMANCE			
Full throttle operating range		r/min	5,000 ~ 6,000
Maximum output		kW (HP) @ r/min	22.1 (30) @5,500
Idling speed (Neutral)		r/min	800 ~ 900
ENGINE			
Type			4-stroke, OHC, L3
Displacement		cm ³ (cu.in.)	747 (45.5)
Bore × stroke		mm (in.)	65 × 75 (2.56 × 2.95)
Ignition system			CDI system
Spark plug		NGK	DPR6EA-9
Spark plug gap		mm (in.)	0.9 (0.035)
Control system			Remote control
Starting system			Electric start
Valve clearance (cold engine)	IN	mm (in.)	0.15 ~ 0.25 (0.006 ~ 0.010)
	EX	mm (in.)	0.25 ~ 0.35 (0.010 ~ 0.014)
Battery			
Min. cold cranking amps (CCA/SAE)		amps at -18°C (-0.4°F)	380
Min. marine cranking amps (MCA/ABYC)		amps at 0°C (32°F)	502
Min. reserve capacity (RC/SAE)		minutes	124
Alternator output		V-A(W)	12-15
Starting carburetion system			Prime start
DRIVE UNIT			
Gear positions			Forward-Neutral-Reverse
Gear ratio			2.0 (26/13)
Trim/tilt system			Power trim & tilt
Propeller mark			G
FUEL AND OIL			
Recommended fuel		P.O.N.	Regular unleaded gasoline (Minimum 86)
Fuel tank capacity		l (US gal, Imp gal)	—
Recommended engine oil		API	4-stroke motor oil
		SAE	SE, SF, SG, SH, SJ
Engine oil capacity (without oil filter)		l (US qt, Imp qt)	10W-30, 10W-40
(with oil filter)		l (US qt, Imp qt)	2.0 (2.11, 1.76)
Recommended gear oil			2.2 (2.33, 1.94)
Gear oil capacity		cm ³ (US oz, Imp oz)	Hypoid gear oil (SAE90)
			430 (14.54, 15.14)
TIGHTENING TORQUE			
Spark plug		N·m (kgf·m, lb·ft)	14.7 ~ 19.6 (1.5 ~ 2.0, 11 ~ 14)
Propeller nut		N·m (kgf·m, lb·ft)	29.4 ~ 49.0 (3.0 ~ 5.0, 22 ~ 36)
Engine oil drain bolt		N·m (kgf·m, lb·ft)	14.7 ~ 19.6 (1.5 ~ 2.0, 11 ~ 14)
Engine oil filter		N·m (kgf·m, lb·ft)	15.0 ~ 20.0 (1.5 ~ 2.0, 11 ~ 14)

* Listed weight does not include propeller.



F40MHB	F40ERB	F40TRB
1,332 (52.4) 378 (14.9) 1,217 (47.9)/1,340 (52.8)/ — 410 (16.1)/533 (21.0)/ — 83* (183)/87* (192)/ —	700 (27.6) 378 (14.9) 1,217 (47.9)/1,340 (52.8)/ — 410 (16.1)/533 (21.0)/ — 82* (181)/— / —	700 (27.6) 378 (14.9) 1,217 (47.9)/1,340 (52.8)/ — 410 (16.1)/533 (21.0)/ — 82* (181)/89* (196)/ —
5,000 ~ 6,000 29.4 (40) @5,500 800 ~ 900	5,000 ~ 6,000 29.4 (40) @5,500 800 ~ 900	5,000 ~ 6,000 29.4 (40) @5,500 800 ~ 900
4-stroke, OHC, L3 747 (45.5) 65 × 75 (2.56 × 2.95) CDI system DPR6EA-9 0.9 (0.035) Tiller control Manual recoil starter 0.15 ~ 0.25 (0.006 ~ 0.010) 0.25 ~ 0.35 (0.010 ~ 0.014) — — — 12-(80) Prime start	4-stroke, OHC, L3 747 (45.5) 65 × 75 (2.56 × 2.95) CDI system DPR6EA-9 0.9 (0.035) Remote control Electric start 0.15 ~ 0.25 (0.006 ~ 0.010) 0.25 ~ 0.35 (0.010 ~ 0.014) 380 502 124 12-15 Prime start	4-stroke, OHC, L3 747 (45.5) 65 × 75 (2.56 × 2.95) CDI system DPR6EA-9 0.9 (0.035) Remote control Electric start 0.15 ~ 0.25 (0.006 ~ 0.010) 0.25 ~ 0.35 (0.010 ~ 0.014) 380 502 124 12-15 Prime start
Forward-Neutral-Reverse 2.0 (26/13) Hydro tilt G	Forward-Neutral-Reverse 2.0 (26/13) Hydro tilt G	Forward-Neutral-Reverse 2.0 (26/13) Power trim & tilt G
Regular unleaded gasoline (Minimum 86) — 4-stroke motor oil SE, SF, SG, SH, SJ 10W-30, 10W-40 2.0 (2.11, 1.76) 2.2 (2.33, 1.94) Hypoid gear oil (SAE90) 430 (14.54, 15.14)	Regular unleaded gasoline (Minimum 86) — 4-stroke motor oil SE, SF, SG, SH, SJ 10W-30, 10W-40 2.0 (2.11, 1.76) 2.2 (2.33, 1.94) Hypoid gear oil (SAE90) 430 (14.54, 15.14)	Regular unleaded gasoline (Minimum 86) — 4-stroke motor oil SE, SF, SG, SH, SJ 10W-30, 10W-40 2.0 (2.11, 1.76) 2.2 (2.33, 1.94) Hypoid gear oil (SAE90) 430 (14.54, 15.14)
14.7 ~ 19.6 (1.5 ~ 2.0, 11 ~ 14) 29.4 ~ 49.0 (3.0 ~ 5.0, 22 ~ 36) 14.7 ~ 19.6 (1.5 ~ 2.0, 11 ~ 14) 15.0 ~ 20.0 (1.5 ~ 2.0, 11 ~ 14)	14.7 ~ 19.6 (1.5 ~ 2.0, 11 ~ 14) 29.4 ~ 49.0 (3.0 ~ 5.0, 22 ~ 36) 14.7 ~ 19.6 (1.5 ~ 2.0, 11 ~ 14) 15.0 ~ 20.0 (1.5 ~ 2.0, 11 ~ 14)	14.7 ~ 19.6 (1.5 ~ 2.0, 11 ~ 14) 29.4 ~ 49.0 (3.0 ~ 5.0, 22 ~ 36) 14.7 ~ 19.6 (1.5 ~ 2.0, 11 ~ 14) 15.0 ~ 20.0 (1.5 ~ 2.0, 11 ~ 14)



EMU01369

TRANSPORTING AND STORING OUTBOARD MOTOR

⚠ WARNING

Leaking fuel is a fire hazard. When transporting and storing the outboard motor, close the air vent screw and fuel cock to prevent fuel from leaking.

EMU00326

TRAILERING OUTBOARD MOTOR

The motor should be trailered and stored in the normal running position. If there is insufficient road clearance in this position, then trailer the motor in the tilt position using a motor support device such as a transom saver bar.

For further details, consult your Yamaha dealer.

⚠ WARNING

- Never get under the lower unit while it is tilted, even if a motor support bar is used. Severe injury could occur if the outboard accidentally falls.
- USE CARE when transporting fuel tank, whether in a boat or car.
- DO NOT fill fuel container to maximum capacity. Gasoline will expand considerably as it warms up and can build up pressure in the fuel container. This can cause fuel leakage and a potential fire hazard.

CAUTION:

Do not use the tilt support lever/knob when trailering the boat. The outboard motor could shake loose from the tilt support and fall. If the motor can not be trailered in the down position, use an additional support device to secure it in the up position.



EMU00330

STORING OUTBOARD MOTOR

When storing your Yamaha outboard for prolonged periods of time, (2 months or longer), several important procedures must be performed to prevent expensive damage.

It is advisable to have your outboard serviced by an authorized Yamaha dealer prior to storage. However, the following procedures can be performed by you, the owner, with a minimum of tools.

CAUTION:

- To prevent problems which can be caused by oil entering the cylinder from the sump, keep the engine in the attitude shown when transporting and storing it.
- Do not place the engine on its side before the cooling water has drained from it completely, or water may enter the cylinder through the exhaust port and cause problems.
- Store the engine in a dry, well-ventilated place, not in direct sunlight.

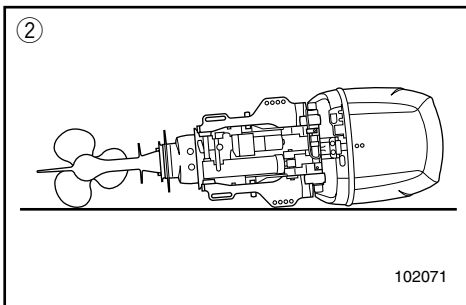
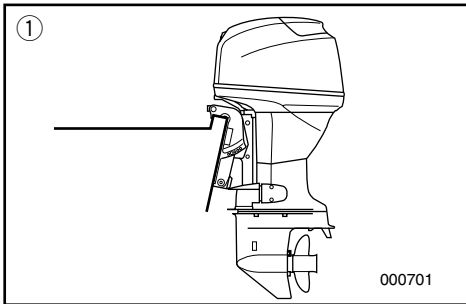

- ① Vertical position
② Horizontal position



EMU00338

Flushing Cooling System and Fogging Engine

Cooling system flushing is essential to prevent the cooling system from clogging up with salt, sand, or dirt. In addition, fogging of the engine is mandatory to prevent expensive engine damage due to rust. Perform the flushing and fogging at the same time.

⚠ WARNING

- **Do not touch or remove electrical parts when starting or during operation.**
- **Keep hands, hair and clothes away from flywheel and other rotating parts while engine is running.**

EMU00339

• **Flushing in a Water Tank**

CAUTION:

If the fresh water level is below the level of the anti-cavitation plate, or if the water supply is insufficient, engine seizure may occur.

- 1) Remove the engine top cowling and silencer cover.
- 2) Install the outboard motor on the water tank.
- 3) Fill the tank with fresh water to above the level of the anti-cavitation plate.
- 4) Run the engine at a fast idle for 10~15 minutes.
- 5) Just prior to turning off the engine, quickly spray "Yamaha Stor-Rite Engine Fogging Oil" (Part No. LUB-STRRT-12-00) alternately into each carburetor. When properly done, the engine will smoke excessively and almost stall.

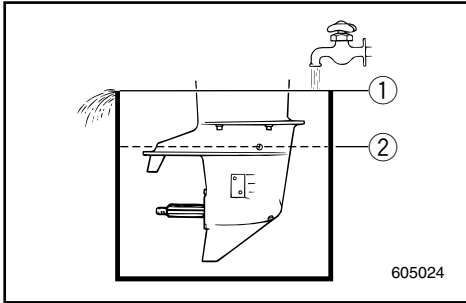

- 6) Remove the motor from the water tank.
- 7) Install the silencer cover and top cowling.

- ① Water surface
② Lowest water level

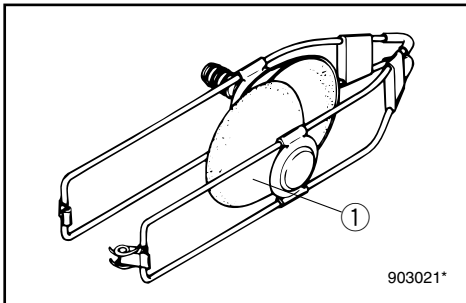

EMU00342

● **Flushing with the Flushing Attachment**

CAUTION: _____

Avoid running the outboard at high speed while on the flushing attachment, or overheating could occur.

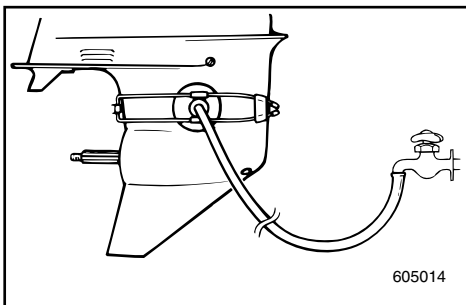

- 1) Remove the top cowling and the propeller.
- 2) Install a flushing attachment ① to the cooling water inlet.
- 3) Run the engine at a fast idle for 10~15 minutes supplying fresh water.
- 4) Just prior to turning off the engine, quickly spray "Yamaha Stor-Rite Engine Fogging Oil" (Part No. LUB-STRRT-12-00) alternately into the silencer cover. When properly done, the engine will smoke excessively and almost stall.
- 5) Remove the flushing attachment and wipe off any excess water.
- 6) Install the top cowling and the propeller.

NOTE: _____

A flushing attachment is available from a Yamaha dealer.



EMU00349

Lubrication

- 1) Remove the spark plug(s). Spray a Yamaha "Stor-Rite Engine Fogging Oil" into each cylinder for 10 seconds. Grease the spark plug threads and reinstall the spark plug(s) and torque to proper specification. (Refer to the "CLEANING AND ADJUSTING SPARK PLUG").
- 2) Turn the engine over with the stop lanyard disconnected to work the fogging oil into the piston rings.
- 3) Change the gear-case oil. (Refer to "CHANGING GEAR OIL"). Inspect the oil for the presence of water which indicates a leaky seal. Seal replacement should be performed by an authorized Yamaha dealership prior to use.
- 4) Grease all grease fittings. (Refer to the "GREASING")

EMU00351

Cleaning and Anti-corrosion Measure

- 1) Wash down the exterior of the outboard with fresh water and dry off completely.
- 2) Spray the engine's exterior with "Yamaha Silicone Protectant" (Part No. LUB-SILCNE-13-00).
- 3) Wax the cowling with a non-abrasive wax such as "Yamaha Silicone Wax" (Part No. ACC-11000-15-02).



EMU00353

Battery Care

⚠️ WARNING

Battery electrolyte is poisonous and dangerous, causing severe burns, etc. It contains sulfuric acid. Avoid contact with skin, eyes, or clothing.

Antidote:

EXTERNAL; Flush with water.

INTERNAL; Drink large quantities of water or milk. Follow with milk of magnesia, beaten egg, or vegetable oil. Call physician immediately.

EYES; Flush with water for 15 minutes and get prompt medical attention.

Batteries produce explosive gases: Keep sparks, flame, cigarettes, etc. away. Ventilate when charging or using in a closed space. Always wear eye protection when working near batteries.

KEEP OUT OF REACH OF CHILDREN.

Batteries vary among manufacturers. Therefore the following procedures may not always apply. Consult your battery manufacturer's instructions.

- 1) Disconnect and remove the battery from the boat. Always disconnect the black negative lead first to prevent the risk of shorting.
- 2) Clean the battery casing and terminals. Fill each cell to the upper level with distilled water.
- 3) Store the battery on a level surface in a cool, dry, well-ventilated place out of direct sunlight.
- 4) Once a month, check the specific gravity of the electrolyte and recharge as required to prolong battery life.

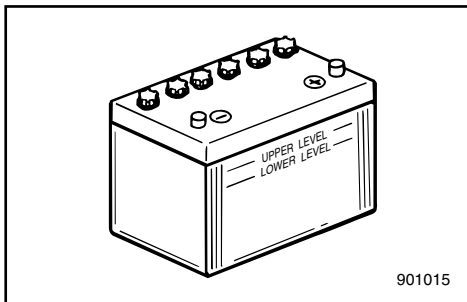



EMU01569

PERIODIC MAINTENANCE

⚠ WARNING

Be sure to turn off the engine when you perform maintenance unless otherwise specified. If the owner is not familiar with machine servicing, this work should be done by a Yamaha dealer or other qualified mechanic.

Maintenance, replacement, or repair of the emission control devices and systems may be performed by any marine engine repair establishment or individual. All warranty repairs, however, including those to the emission control system, must be performed by an authorized Yamaha marine dealership.

A service manual is available for purchase through a Yamaha dealer for owners who have the mechanical skills, tools, and other equipment necessary to perform maintenance not covered by this owner's manual.

EMU00356

REPLACEMENT PARTS

If replacement parts are necessary, use only genuine Yamaha parts or equivalents of the same type and of equivalent strength and materials. Any part of inferior quality may malfunction, and the resulting loss of control could endanger the operator and passengers.

Yamaha genuine parts and accessories are available from a Yamaha dealer.



EMU00361*

MAINTENANCE CHART

Frequency of maintenance operations may be adjusted according to the operating conditions, but the following table gives general guidelines.

The mark (●) indicates the check-ups which you may carry out yourself.

The mark (○) indicates work to be carried out by your Yamaha dealer.

Item		Interval	Initial		Every		Refer page
			10 hours (1 month)	50 hours (3 months)	100 hours (6 months)	200 hours (1 year)	
Spark plug	Cleaning/Adjustment/ Replacement	●	●	●			4-12
Greasing points	Greasing			●			4-11
Gear oil	Change	●		●			4-24
Fuel system	Inspection			●			4-14
Fuel filter	Inspection/Replacement	●	●	●			4-15
Fuel tank *1	Cleaning				●		—
Idling speed	Adjustment	●		●			4-16
Anode	Inspection/Replacement		○	○			4-25
Outboard motor exterior	Inspection		●	●			4-30
Cooling water passages *2	Cleaning		●	●			4-5, 4-29
Propeller	Inspection		●	●			4-22
Timing belt	Inspection/Replacement			○			4-19
Battery	Inspection	● (every month)					4-26
Power trim/tilt	Inspection	●	●	●			4-21
Ignition timing	Inspection/Adjustment	○			○		—
Bolts/Nuts	Retightening	○		○			4-29
Engine oil	Change	●		●			4-17
Oil filter	Change				○		—
Valve clearance	Inspection/Adjustment	○		○			—
Thermostat	Inspection				○		—

*1. If a portable fuel tank is included with the engine.

*2. When operating in salt water, turbid or muddy water, the engine should be flushed with clean water after each use.

NOTE:

If leaded gasoline is usually used, engine valves and related parts should be inspected after every 300 hours of operation in addition to the items on the maintenance chart above.



EMU00366

GREASING

Yamaha marine grease
(Water resistant grease)

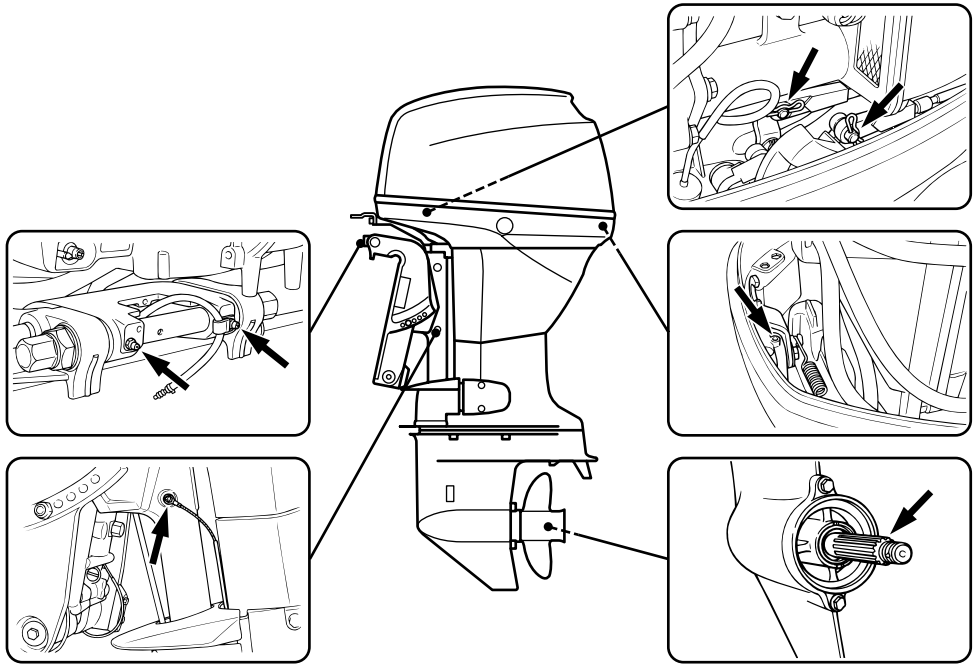

103211



EMU01202

CLEANING AND ADJUSTING SPARK PLUG

⚠ WARNING

When removing or installing a spark plug, be careful not to damage the insulator. A damaged insulator could allow external sparks, which could lead to explosion or fire.

The spark plug is an important engine component and is easy to inspect. The condition of the spark plug can indicate something about the condition of the engine. For example, if the center electrode porcelain is very white, this could indicate an intake air leak or carburetion problem in that cylinder. Do not attempt to diagnose any problems yourself. Instead, take the outboard motor to a Yamaha dealer. You should periodically remove and inspect the spark plug because heat and deposits will cause the spark plug to slowly break down and erode. If electrode erosion becomes excessive, or if carbon and other deposits are excessive, you should replace the spark plug with another of the correct type.

Standard spark plug:
Refer to "SPECIFICATIONS", page 4-1

Before fitting the spark plug, measure the electrode gap with a wire thickness gauge; adjust the gap to specification if necessary.

Spark plug gap:
Refer to "SPECIFICATIONS", page 4-1



When fitting the plug, always clean the gasket surface and use a new gasket. Wipe off any dirt from the threads and screw in the spark plug to the correct torque.

Spark plug torque:
Refer to "SPECIFICATIONS", page 4-1

NOTE: _____

If a torque-wrench is not available when you are fitting a spark plug, a good estimate of the correct torque is 1/4 to 1/2 a turn past finger-tight. Have the spark plug adjusted to the correct torque as soon as possible with a torque-wrench.

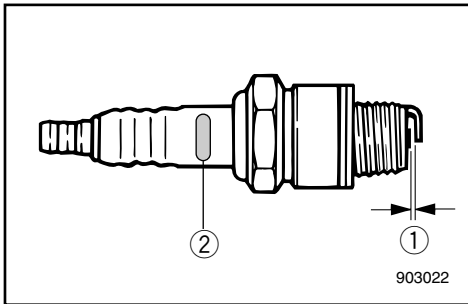

Initial of spark plug I.D. mark	Plug wrench size
B	21 mm (13/16 in.)
C	16 mm (5/8 in.)
D	18.3 mm (23/32 in.)

- ① Spark plug gap
- ② Spark plug I.D. mark (NGK)

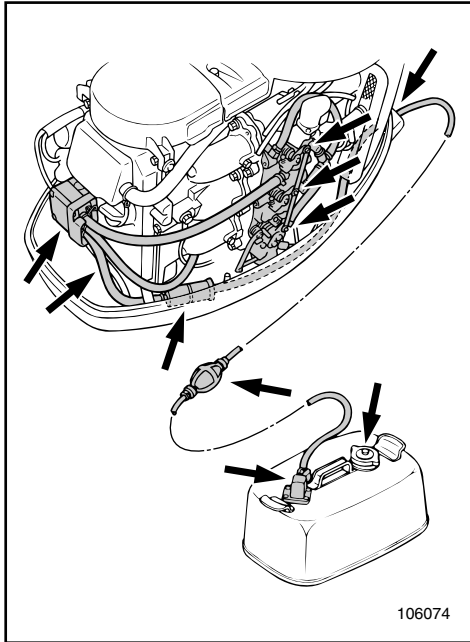

EMU00369

CHECKING FUEL SYSTEM

⚠ WARNING

Gasoline (petrol) and its vapors are highly flammable and explosive. Keep away from sparks, cigarettes, flames or other sources of ignition.

Check the fuel line for leaks, cracks, or malfunctions. If any problem is found, it should be repaired immediately by Yamaha dealer or other qualified mechanic.

Checking points

- Fuel system parts leakage.
- Fuel hose joint leakage.
- Fuel hose cracks or other damage.
- Fuel connector leakage.

⚠ WARNING

Leaking fuel can result in fire or explosion.

- Check for fuel leakage regularly.
- If any fuel leakage is found, the fuel system must be repaired by a qualified mechanic. Improper repairs can make the outboard unsafe to operate.



EMU00370

INSPECTING FUEL FILTER

⚠ WARNING

Gasoline (petrol) is highly flammable, and its vapors are flammable and explosive.

- If you have any question about properly doing this procedure, consult your Yamaha dealer.
- Do not perform this procedure on a hot or running engine. Allow the engine to cool.
- There will be fuel in the fuel filter. Keep away from sparks, cigarettes, flames or other sources of ignition.
- This procedure will allow some fuel to spill. Catch fuel in a rag. Wipe up any spilled fuel immediately.
- The fuel filter must be reassembled carefully with O-ring, filter cup, and hoses in place. Improper assembly or replacement can result in a fuel leak, which could result in a fire or explosion hazard.

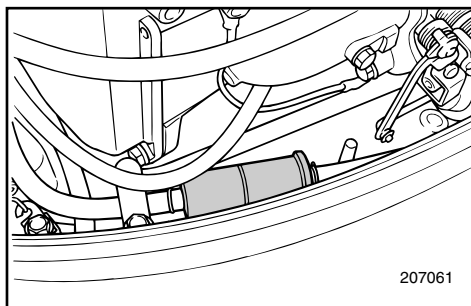

EMU00374

Check the fuel filter periodically.

The fuel filter is a one-piece, disposable type. If foreign matter is found in the filter, replace it. For replacement of the fuel filter, consult a Yamaha dealer.



EMU00991

ADJUSTING IDLING SPEED

⚠WARNING

- Do not touch or remove electrical parts when starting or during operation.
- Keep hands, hair and clothes away from flywheel and other rotating parts while engine is running.

CAUTION:

This procedure must be performed while the outboard motor is in the water. A flushing attachment or test tank can be used.

A diagnostic tachometer should be used for this procedure.

- 1) Start the engine and allow it to warm up fully in Neutral until it is running smoothly. If the outboard is mounted on a boat, be sure the boat is tightly moored.
- 2) Adjust the throttle stop-screw ① to set the idling speed to specification (see "SPECIFICATIONS" on page 4-1) by turning the stop-screw clockwise to increase the idling speed, and turning it counterclockwise to decrease the idling speed.

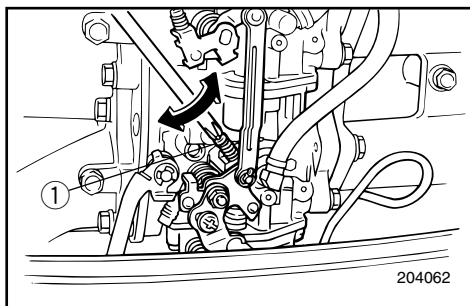

NOTE:

Correct idling-speed adjustment is only possible if the engine is fully warmed-up. If not warmed up fully, the speed setting will tend to be too high. If you have difficulty obtaining the specified idle, consult a Yamaha dealer or other qualified mechanic.



EMU01415

CHANGING ENGINE OIL

⚠ WARNING

- Avoid draining the engine oil immediately after stopping the engine. The oil is hot and should be handled with care to avoid burns.
- Be sure the outboard is securely fastened to the transom or a stable stand.

CAUTION:

- Change the engine oil after the first 10 hours of operation, and every 100 hours or at 6-month intervals thereafter. Otherwise, the engine will wear quickly.
- Do not overfill the oil, and be sure the engine is in an upright position (not tilted) when checking and changing the engine oil.
- If the oil level is above the upper level mark, drain until the level meets the specified capacity. Overfilling the oil may cause leakage or damage.

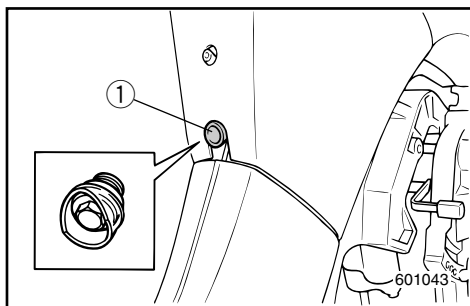
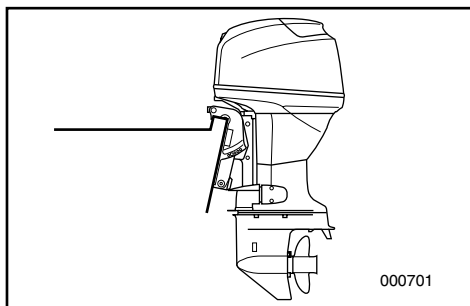

- 1) Put the outboard motor in an upright position (not tilted).
- 2) Prepare a suitable container which can hold a larger amount than the engine oil capacity. Loosen and remove the drain bolt ① while holding the container under the drain hole. Let the oil drain completely. Wipe up any spilled oil immediately.
- 3) Put a new gasket on the drain bolt. Apply a light coat of oil to the gasket and reinstall the drain bolt.

Tightening torque:
Refer to "SPECIFICATIONS", page 4-1.

**NOTE:**

If a torque wrench is not available when you are installing the drain plug, finger tighten the bolt just until the gasket comes into contact with the surface of the drain hole. Then tighten 1/4 - 1/2 turn. Have the drain plug torqued to the correct value with a torque wrench as soon as possible.

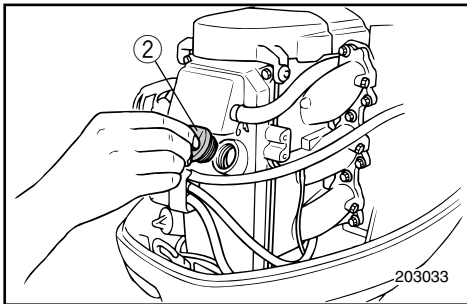

- 4) Remove the oil filler cap (2). Add the correct amount of oil through the filler hole.
Reinstall the filler cap.

Engine oil grade/capacity:
Refer to "SPECIFICATIONS", page 4-1.

- 5) Start the engine and watch to make sure the low oil pressure warning lamp turns off. Make sure that there are no oil leaks.

CAUTION:

If the oil lamp does not turn off, or if there are oil leaks, stop the engine and find the cause. Continued operation with a problem could cause severe engine damage. If the problem cannot be found and corrected, consult your Yamaha dealer.

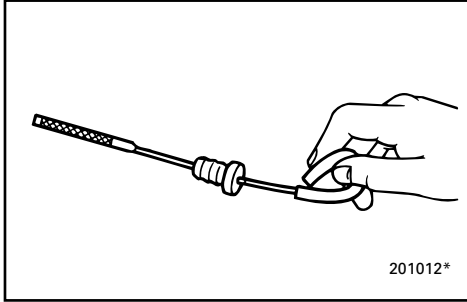

- 6) Turn off the engine and wait 3 minutes. Recheck the oil level using the dipstick to be sure the level falls between the upper and lower marks. Fill with oil if it is below the lower mark, or drain to the specified level if it is above the upper mark.
- 7) Dispose of used oil according to local regulations.

NOTE: _____

- For disposal of used oil consult your Yamaha dealer.
- The oil should be changed more often when the engine is operated under adverse conditions such as extended trolling.

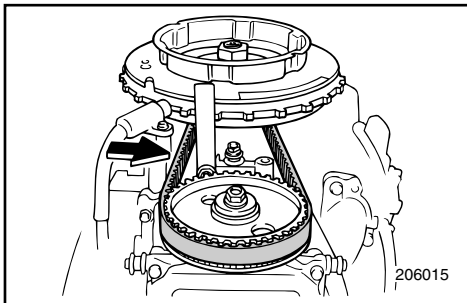

EMU00381

CHECKING TIMING BELT

Inspect the timing-belt and replace it if any of the following signs is observed:

- Cracks in the back of the belt or in the base of belt teeth.
- Excessive wear at the roots of cogs.
- Rubber portion swollen by oil.
- Belt surfaces roughened.
- Signs of wear on edges or outer surface of belt.

CAUTION: _____

Consult your Yamaha dealer when replacing or adjusting the timing-belt.

NOTE: _____

If the timing belt can be stretched by 10 mm (0.39 in) or more by pushing with your finger in the middle between the pulleys, the belt tension needs adjust.

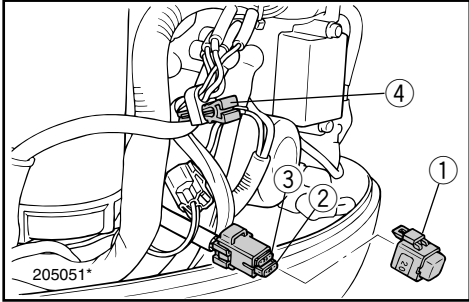

EMU01015

REPLACING FUSE

If the fuse has blown for Electric start model, open the fuse box and replace the fuse with a spare one of proper amperage, using a fuse puller.

⚠WARNING

Be sure to use the specified fuse. A wrong fuse or a piece of wire may allow excessive current flow. This could cause electrical system damage and a fire hazard.

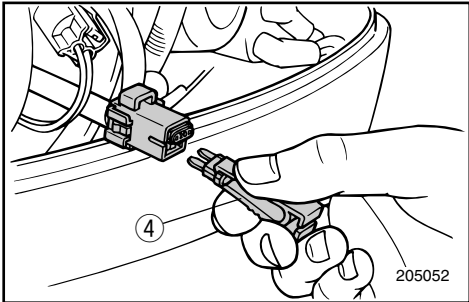

NOTE:

If the new fuse blows again immediately, consult a Yamaha dealer.

- ① Fuse box
- ② Fuse (20A)
- ③ Spare fuse (20A)
- ④ Fuse puller

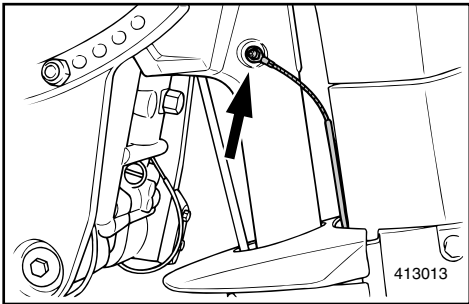

EMU00383

CHECKING WIRING AND CONNECTORS

- 1) Check that each grounding wire is properly secured.
- 2) Check that each connector is engaged securely.

EMU00384

EXHAUST LEAKAGE

Start the engine and check that no exhaust leaks from the joints between the exhaust cover, cylinder head and crank case.

EMU00385

WATER LEAKAGE

Start the engine and check that no water leaks from the joints between the exhaust cover, cylinder head and crank case.



EMU00992

CHECKING POWER TRIM AND TILT SYSTEM

▲WARNING

- Never get under the lower unit while it is tilted, even when the tilt-support lever is locked. Severe injury could occur if the outboard accidentally falls.
- Make sure no one is under the outboard before performing this test.

- 1) Check the power trim and tilt unit for any sign of oil leaks.
- 2) Operate each of the power trim and tilt switches on remote control and engine bottom cowling (if equipped) to check that all switches work.
- 3) Tilt up the motor and check that the trim and tilt rod ① is pushed out completely.
- 4) Check that the trim and tilt rod is free of corrosion or other flaws.
- 5) Operate the motor to trim and tilt down. Check that the trim and tilt rod operates smoothly.

NOTE:

If any operation is abnormal, consult a Yamaha dealer.

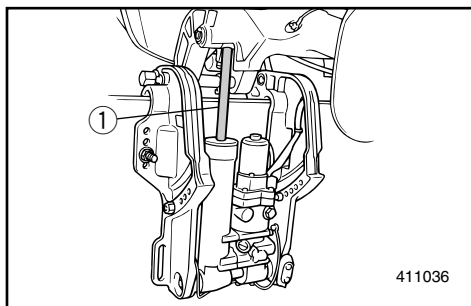

Recommended fluid;
Yamaha power trim & tilt fluid or ATF
(DEXRON-II)

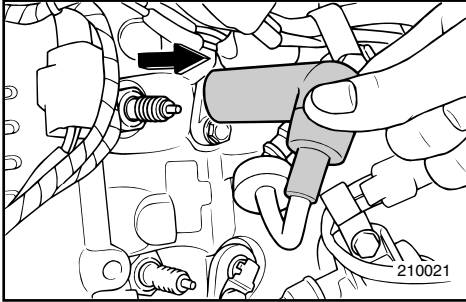

EMU00388

CHECKING PROPELLER

⚠WARNING

You could be seriously injured if the engine accidentally starts while you are near the propeller.

- Before inspecting, removing or installing the propeller, remove the spark plug caps from the spark plugs. Also, put the shift control in Neutral, put the main switch in the "OFF" position and remove the key, and remove the lanyard from the engine stop switch. Turn off the battery cut-off switch if your boat has one.
- Do not use your hand to hold the propeller when loosening or tightening the propeller nut. Put a wood block between the cavitation plate and the propeller to prevent the propeller from turning.

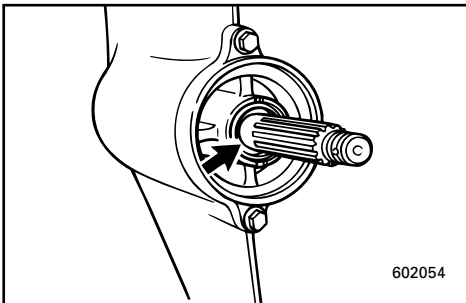
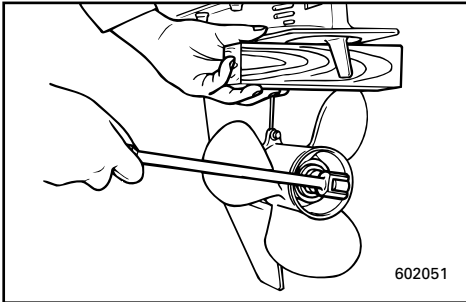

EMU00390

Propeller Checking Point

- Check each of the propeller blades for wear, erosion from cavitation or ventilation, or other damage.
- Check the splines for wear and damage.
- Check for fish line winding around the propeller shaft.
- Check the propeller shaft oil seal for damage.

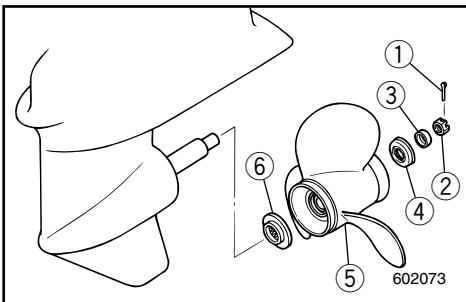

EMU00976

Removing the Propeller

- 1) Straighten the cotter-pin ① and pull it out using a pair of pliers.
- 2) Remove the propeller nut ②, washer ③ and spacer ④.
- 3) Remove the propeller ⑤ and thrust washer ⑥.



EMU00397

Installing the Propeller

CAUTION:

- Be sure to install the thrust washer before installing propeller, otherwise, lower case and propeller boss may be damaged.
- Be sure to use a new cotter pin and bend the ends over securely. Otherwise, the propeller could come off during operation and be lost.

- 1) Apply Yamaha Marine grease or Corrosion resistant grease to the propeller-shaft.
- 2) Install the thrust washer and propeller on the propeller-shaft.
- 3) Install the spacer and washer. Tighten the propeller nut to the specified torque.

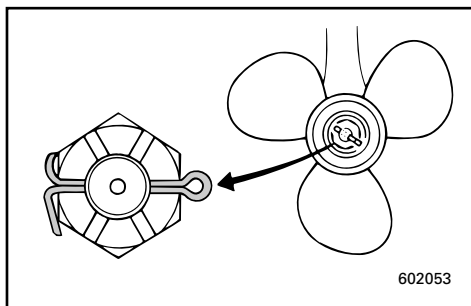

Tightening torque:

Refer to "SPECIFICATIONS" page 4-1.

- 4) Align the propeller nut with the propeller shaft hole. Insert a new cotter pin in the hole and bend the cotter pin ends.

NOTE:

If the propeller nut does not align with the propeller shaft hole after tightening to the specified torque, then tighten the nut further to align it with the hole.



EMU01460

CHANGING GEAR OIL

⚠WARNING

- Be sure the outboard is securely fastened to the transom or a stable stand. You could be severely injured if the outboard falls on you.
- Never get under the lower unit while it is tilted, even when the tilt-support lever/knob is locked. Severe injury could occur if the outboard accidentally falls.

- 1) Tilt the outboard motor so that the oil drain plug is at the lowest point possible.
- 2) Place a suitable container under the gear-case.

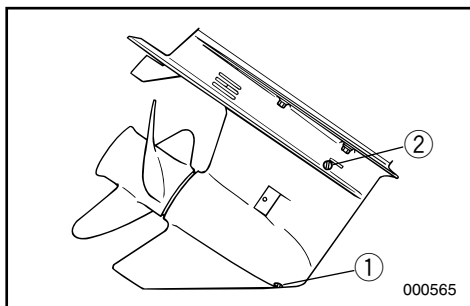

- 3) Remove the oil drain plug ①.

NOTE:

The oil drain plug is magnetic. Remove all metal particles from the plug before reinstalling it.

- 4) Remove the oil level plug ② to allow the oil to drain completely.

CAUTION:

Inspect the used oil after it has been drained. If the oil is milky, water is getting into the gear-case which can cause gear damage. Consult a Yamaha dealer for repair of the lower unit seals.

NOTE:

For disposal of used oil consult your Yamaha dealer.

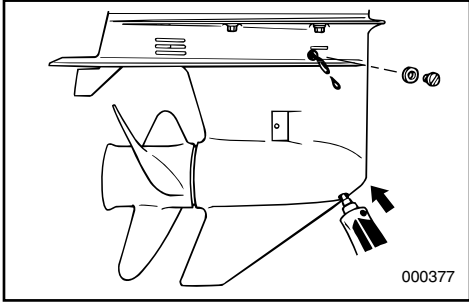

5) With the outboard motor in a vertical position, and using a flexible or pressurized filling device, inject the gear oil into the oil drain plug hole.

Gear oil grade/capacity:
Refer to "SPECIFICATIONS,"
page 4-1.

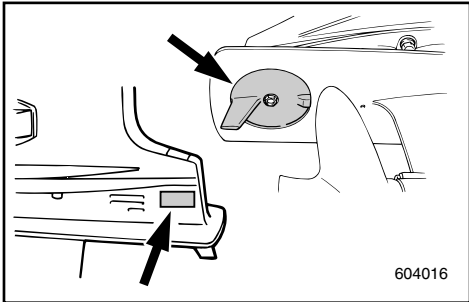

6) When the oil begins to flow out of the oil level plug hole, insert and tighten the oil level plug.

7) Insert and tighten the oil drain plug.

EMU01037

INSPECTING AND REPLACING ANODE(S)

Yamaha outboard motor is protected from corrosion by a sacrificial anode(s). Check the anode(s) periodically. Remove the scales from surfaces of the anode(s). For the inspection and replacement of the anode(s), consult a Yamaha dealer.

CAUTION: _____

Do not paint the anode(s), for this would render it ineffective.

NOTE: _____

Remove the cover with anode after removing the bolts ① when checking the anode condition.

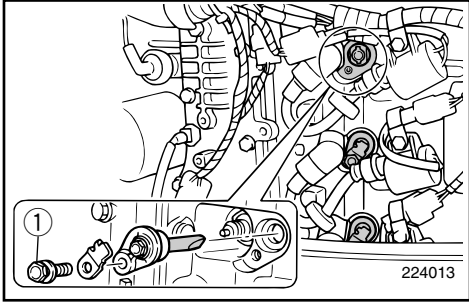
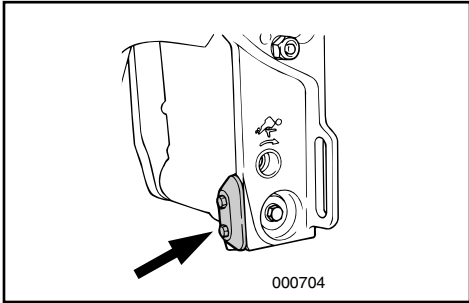



EMU00404

CHECKING BATTERY (for Electric start model)

⚠WARNING

Battery electrolytic fluid is dangerous; it contains sulfuric acid and therefore is poisonous and highly caustic.

Always follow these preventive measures:

- Avoid bodily contact with electrolytic fluid as it can cause severe burns or permanent eye injury.
- Wear protective eye gear when handling or working near batteries.

Antidote (EXTERNAL):

- SKIN - Flush with water.
- EYES - Flush with water for 15 minutes and get immediate medical attention.

Antidote (INTERNAL):

- Drink large quantities of water or milk followed by milk of magnesia, beaten egg, or vegetable oil. Get immediate medical attention.

Batteries also generate explosive hydrogen gas; therefore, you should always follow these preventive measures:

- Charge batteries in a well-ventilated area.
- Keep batteries away from fire, sparks, or open flames (e.g., welding equipment, lighted cigarettes, etc.).
- DO NOT SMOKE when charging or handling batteries.
- KEEP BATTERIES AND ELECTROLYTIC FLUID OUT OF REACH OF CHILDREN.

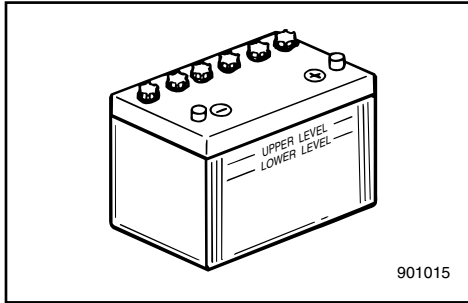
**CAUTION:**

- A poorly maintained battery will quickly deteriorate.
- Ordinary tap-water contains minerals harmful to a battery, and should not be used for topping-up.

- 1) Check the electrolyte level at least once a month. Fill to the manufacturer's recommended level when necessary. Top up only with distilled water (or pure de-ionized water suitable to use in batteries).
- 2) Keep the battery always in a good state of charge. Installing a voltmeter will help you monitor your battery. If you will not use the boat for a month or more, remove the battery from the boat and store it in a cool, dark place. Completely recharge the battery before using it.
- 3) If the battery will be stored for longer than a month, check the specific gravity of the fluid at least once a month and recharge the battery when it is low.



EEMU01279

Connecting the Battery

⚠️ WARNING

Mount the battery holder securely in a dry, well-ventilated, vibration-free location in the boat. Install a fully charged battery in the holder.

CAUTION:

- Make sure the main switch (on applicable models) is "OFF" before working on the battery.
- Reversal of the battery leads will damage the rectifier.
- Connect the RED lead first when installing the battery and disconnect the RED lead last when removing it. Otherwise, the electrical system can be damaged.
- The electrical contacts of the battery and cables must be clean and properly connected, or the battery will not start the engine.

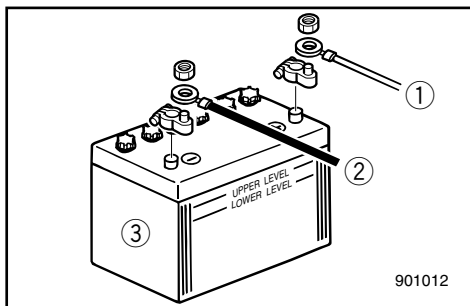

Connect the RED lead to the POSITIVE (+) terminal first.

Then connect the BLACK lead to the NEGATIVE (-) terminal.

- ① Red lead
- ② Black lead
- ③ Battery

EMU01280

Disconnecting the Battery

Disconnect the BLACK lead from the NEGATIVE (-) terminal first. Then disconnect the RED lead from the POSITIVE (+) terminal.



EMU00408

CHECKING BOLTS AND NUTS

- 1) Check that bolts securing the cylinder head and engine and the nut securing the flywheel are tightened with their specified tightening torque.
- 2) Check the tightening torque of other bolts and nuts.

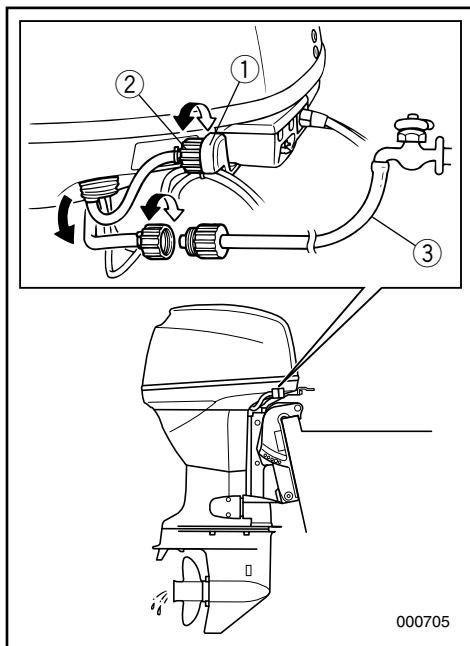

EMU01172

CLEANING COOLING-WATER PASSAGES

Flushing device equipped model

Perform this procedure right after operation for the most thorough flushing.

- 1) After shutting off the engine, unscrew the garden-hose connector ② from the fitting ① on the bottom cowling.
- 2) Screw the garden-hose connector ② onto a garden hose ③ which is connected to a fresh-water supply.
- 3) With the engine off, turn on the water tap and let the water flush through the cooling passages for about 15 minutes. Turn off the water and disconnect the garden hose ③.
- 4) When flushing is complete, reinstall the garden-hose connector ② on the fitting ① on the bottom cowling. Tighten the connector securely.

CAUTION: _____

Do not leave the garden-hose connector loose on the bottom cowling fitting or let the hose hang free during normal operation. Water will leak out of the connector instead of cooling the engine, which can cause serious overheating. Be sure the connector is tightened securely on the fitting after flushing the engine.



NOTE: _____

- When flushing the engine with the boat in the water, tilting up the engine until it is completely out of the water will achieve better results.
- Refer to cooling system flushing instructions in "TRANSPORTING AND STORING OUTBOARD MOTOR".

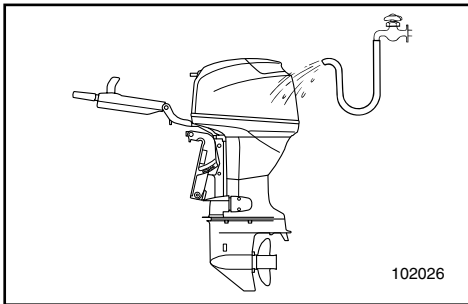

EMU00409

MOTOR EXTERIOR

EMU00410

Cleaning the Outboard Motor

After use, wash the exterior of the outboard with fresh water.

Flush the cooling system with fresh water.

NOTE: _____

Refer to Flushing Cooling System instructions in "TRANSPORTING AND STORING OUTBOARD MOTOR".

EMU00412

Checking Painted Surface of Motor

Check the motor for scratches, nicks, or flaking paint. Areas with damaged paint are more likely to corrode. If necessary, clean and paint the areas. A touch-up paint is available from a Yamaha dealer.

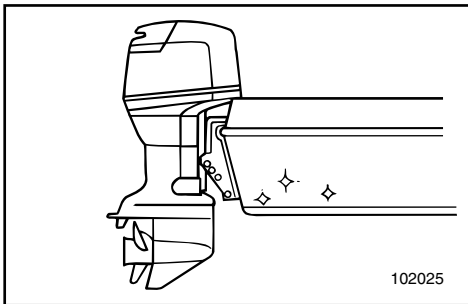

EMU00413

COATING THE BOAT BOTTOM

A clean hull improves boat performance. The boat bottom should be kept as clean of marine growths as possible. If necessary, the boat bottom can be coated with an anti-fouling paint approved for your area to inhibit marine growth.

Do not use anti-fouling paint which includes copper or graphite. These paints can cause more rapid engine corrosion.



- MEMO -

EMU00414

Chapter 5

TROUBLE RECOVERY

TROUBLESHOOTING5-1

**TEMPORARY ACTION IN
EMERGENCY**5-5

Impact damage5-5

Power trim/tilt will not operate.....5-5

Starter will not operate.....5-6

Treatment of submerged motor.....5-9





TROUBLESHOOTING

A problem in the fuel, compression, or ignition systems can cause poor starting, loss of power, or other problems. The troubleshooting chart describes basic checks and possible remedies. (This chart covers all Yamaha outboard motors. Therefore, some items may not apply to your model.)

If your outboard motor requires repair, bring it to a Yamaha dealer.

Trouble	Possible Cause	Remedy
A. Starter will not operate.	<ol style="list-style-type: none">1. Battery capacity weak or low.2. Battery connections loose or corroded.3. Fuse for electric start circuit blown.4. Starter components faulty.5. Shift lever in gear.	<ol style="list-style-type: none">1. Check battery condition. Use battery of recommended capacity.2. Tighten battery cables and clean battery terminals.3. Check for cause of electric overload and repair. Replace fuse with one of correct amperage.4. Have serviced by a Yamaha dealer.5. Shift to neutral.
B. Engine will not start (Starter operates).	<ol style="list-style-type: none">1. Fuel tank empty.2. Fuel contaminated or stale.3. Fuel filter clogged.4. Starting procedure incorrect.5. Fuel pump malfunctions.6. Spark plug(s) fouled or incorrect type.7. Spark plug cap(s) fitted incorrectly.8. Poor connections or damaged ignition wiring.9. Ignition parts faulty.10. Engine stop switch lanyard not attached.11. Engine inner parts damaged.	<ol style="list-style-type: none">1. Fill tank with clean, fresh fuel.2. Fill tank with clean, fresh fuel.3. Clean or replace filter.4. Read "STARTING ENGINE" section.5. Have serviced by a Yamaha dealer.6. Inspect spark plug(s). Clean or replace with recommended type.7. Check and re-fit cap(s).8. Check wires for wear or breaks. Tighten all loose connections. Replace worn or broken wires.9. Have serviced by a Yamaha dealer.10. Attach lanyard.11. Have serviced by a Yamaha dealer.



Trouble	Possible Cause	Remedy
C. Engine idles irregularly or stalls.	<ol style="list-style-type: none">1. Spark plug(s) fouled or incorrect type.2. Fuel system obstructed. 3. Fuel contaminated or stale.4. Fuel filter clogged.5. Failed ignition parts. 6. Warning system activated.7. Spark plug gap incorrect.8. Poor connections or damaged ignition wiring. 9. Specified engine oil not used.10. Thermostat faulty or clogged. 11. Carburetor adjustments incorrect. 12. Fuel pump damaged. 13. Air vent screw on the fuel tank closed.14. Choke knob pulled out.15. Motor angle too high. 16. Carburetor clogged. 17. Fuel joint connection incorrect.18. Throttle valve adjustment incorrect. 19. Battery lead disconnected.	<ol style="list-style-type: none">1. Inspect spark plug(s). Clean or replace with recommended type.2. Check for pinched or kinked fuel line or other obstructions in fuel system.3. Fill tank with clean, fresh fuel.4. Clean or replace filter.5. Have serviced by a Yamaha dealer.6. Find and correct cause of warning.7. Inspect and adjust as specified.8. Check wires for wear or breaks. Tighten all loose connections. Replace worn or broken wires.9. Check and replace oil as specified.10. Have serviced by a Yamaha dealer.11. Have serviced by a Yamaha dealer.12. Have serviced by a Yamaha dealer.13. Open the air vent screw. 14. Return to home position.15. Return to normal operating position.16. Have serviced by a Yamaha dealer.17. Connect correctly.18. Have serviced by a Yamaha dealer.19. Connect securely.



Trouble	Possible Cause	Remedy
D. Warning buzzer sounds or indicator lamp lights.	<ol style="list-style-type: none">1. Cooling system clogged.2. Engine oil level low.3. Heat range of spark plug incorrect.4. Specified engine oil not used.5. Engine oil contaminated or deteriorated.6. Oil filter clogged.7. Oil feed/injection pump malfunctions.8. Load on boat improperly distributed.9. Water pump/thermostat faulty.	<ol style="list-style-type: none">1. Check water intake for restriction.2. Fill oil tank with specified engine oil.3. Inspect spark plug and replace it with recommended type.4. Check and replace oil with specified type.5. Replace oil with fresh, specified type.6. Have serviced by a Yamaha dealer.7. Have serviced by a Yamaha dealer.8. Distribute load to place boat on an even plane.9. Have serviced by a Yamaha dealer.
E. Engine power loss.	<ol style="list-style-type: none">1. Propeller damaged.2. Propeller pitch or diameter incorrect.3. Trim angle incorrect.4. Motor mounted at incorrect height on transom.5. Warning system activated.6. Boat bottom fouled with marine growth.7. Spark plug(s) fouled or incorrect type.8. Weeds or other foreign matter tangled on gear housing.9. Fuel system obstructed.10. Fuel filter clogged.11. Fuel contaminated or stale.12. Spark plug gap incorrect.	<ol style="list-style-type: none">1. Have propeller repaired or replaced.2. Install correct propeller to operate outboard at its recommended speed (r/min) range.3. Adjust trim angle to achieve most efficient operation.4. Have motor adjusted to proper transom height.5. Find and correct cause of warning.6. Clean boat bottom.7. Inspect spark plug(s). Clean or replace with recommended type.8. Remove foreign matter and clean lower unit.9. Check for pinched or kinked fuel line or other obstructions in fuel system.10. Clean or replace filter.11. Fill tank with clean, fresh fuel.12. Inspect and adjust as specified.



Trouble	Possible Cause	Remedy
E. Engine power loss.	13. Poor connections or damaged ignition wiring. 14. Failed ignition parts. 15. Specified engine oil not used. 16. Thermostat faulty or clogged. 17. Air vent screw closed. 18. Fuel pump damaged. 19. Fuel joint connection incorrect. 20. Heat range of spark plug incorrect.	13. Check wires for wear or breaks. Tighten all loose connections. Replace worn or broken wires. 14. Have serviced by a Yamaha dealer. 15. Check and replace oil with specified type. 16. Have serviced by a Yamaha dealer. 17. Open the air vent screw. 18. Have serviced by a Yamaha dealer. 19. Connect correctly. 20. Inspect spark plug and replace it with recommended type.
F. Engine vibrates excessively.	1. Propeller damaged. 2. Propeller shaft damaged. 3. Weeds or other foreign matter tangled on propeller. 4. Motor mounting bolt loose. 5. Steering pivot loose or damaged.	1. Have propeller repaired or replaced. 2. Have serviced by a Yamaha dealer. 3. Remove and clean propeller. 4. Tighten bolt. 5. Tighten or have serviced by a Yamaha dealer.



EMU00416

TEMPORARY ACTION IN EMERGENCY

EMU01492

IMPACT DAMAGE

⚠ WARNING

The outboard motor can be seriously damaged by a collision while operating or trailering. Damage could make the outboard motor unsafe to operate.



If the outboard motor hits any object in the water, follow the procedure below.

- 1) Stop the engine immediately.
- 2) Inspect the control system and all components for damage. Also, inspect the boat for damage.
- 3) Whether damage is found or not, return to the nearest harbor slowly and carefully.
- 4) Have a Yamaha dealer inspect the outboard motor before operating it again.

EMU00419

POWER TRIM/TILT WILL NOT OPERATE

If the engine cannot be tilted up or down with the power trim and tilt because of a discharged battery or a failure with the power trim and tilt unit, the engine can be tilted manually.

- ① Manual valve screw

EMU00420

- 1) Loosen the manual valve screw clockwise until it stops.
- 2) Put the engine in the desired position, then tighten the manual valve screw counterclockwise.

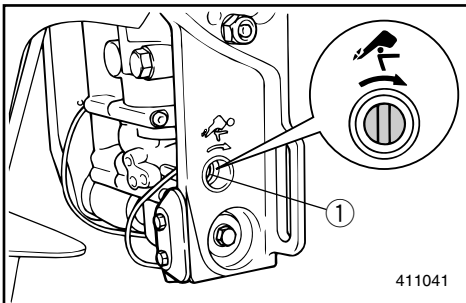



EMU00423

STARTER WILL NOT OPERATE

If the starter mechanism does not operate (engine cannot be cranked with the starter), the engine can be started with an emergency starter rope.

⚠WARNING

- Use this procedure only in an emergency and only to return to port for repairs.
- When the emergency starter rope is used to start the engine, the start-in-gear protection device does not operate. Make sure the gear shift lever/remote control lever is in neutral. Otherwise, the boat could unexpectedly start to move, which could result in an accident.
- Be sure no one is standing behind you when pulling the starter rope. It could whip behind you and injure someone.
- An unguarded rotating flywheel is very dangerous. Keep loose clothing and other objects away when starting the engine. Use the emergency starter rope only as instructed. Do not touch the flywheel or other moving parts when the engine is running. Do not install the starter mechanism or top cowling after the engine is running.
- Do not touch the ignition coil, high voltage wire, spark plug cap or other electrical components when starting of operating the motor. You could be shocked.



EMU01130

Emergency Starting Engine

- 1) Remove the top cowling.
- 2) If the engine is equipped with a start-in-gear protection cable, remove it ① by pulling it out from the starter.

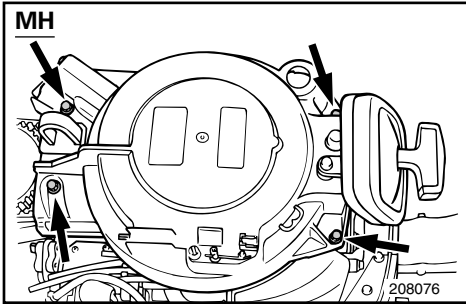
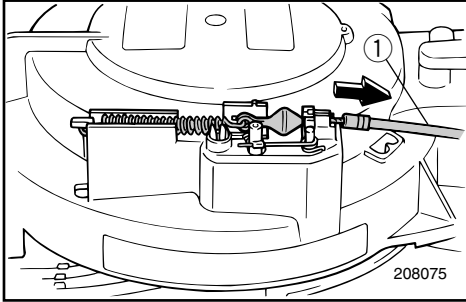

- 3) Remove the starter/flywheel cover by removing the 4 bolts.

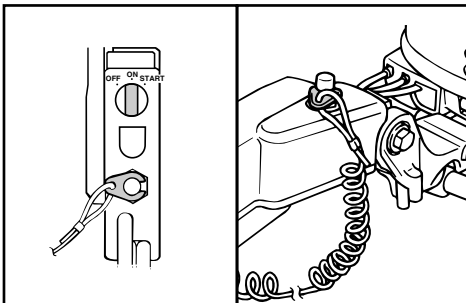
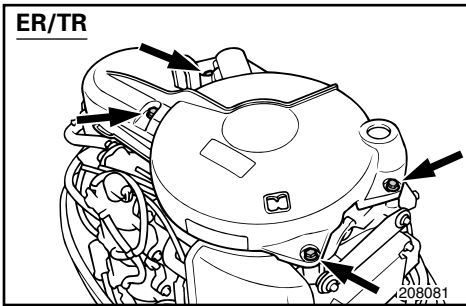

- 4) Prepare the engine for starting. See "STARTING ENGINE" for procedures. Be sure the engine is in Neutral and that the lanyard lock plate is attached to the engine stop lanyard switch. If the engine is equipped with a main switch, it must be on.

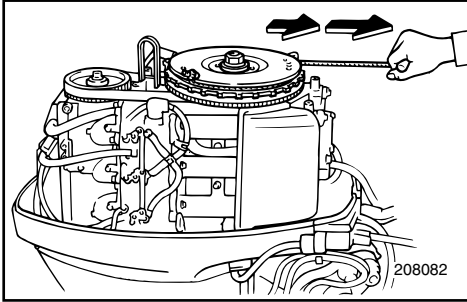

- 5) Insert the knotted end of the emergency starter rope into the notch in the flywheel rotor and wind the rope several turns clockwise.
- 6) Pull the rope slowly until resistance is felt.
- 7) Give a strong pull straight out to crank and start the engine. Repeat if necessary.



EMU00446

TREATMENT OF SUBMERGED MOTOR

If the outboard motor is submerged, immediately take it to a Yamaha dealer. Otherwise, some corrosion may begin almost immediately.

If you cannot immediately take the outboard motor to a Yamaha dealer, follow the procedure below for taking care to minimize engine damage.

EMU00448

- 1) Thoroughly wash away mud, salt, seaweed, etc. with fresh water.
- 2) Remove the spark plug(s), then face the spark plug holes downward to allow any water, mud or contaminants to drain.
- 3) Drain the fuel from the carburetor, fuel filter and fuel line. Drain the engine oil completely.
- 4) Fill the sump with the fresh engine oil as the same quantity as the engine oil capacity.

Engine oil capacity:
Refer to SPECIFICATIONS, Page 4-1.

- 5) Feed engine fogging oil or engine oil through the carburetor(s) and spark plug hole(s) while cranking the engine with the manual starter or emergency starter rope.
- 6) Take the outboard motor to a Yamaha dealer as soon as possible.

CAUTION: _____

Do not attempt to run the motor until it has been completely inspected.

EMU00450

Chapter 6

INDEX

INDEX.....6-1

A to Z



EMU00451

INDEX

- A**
 Adjusting idling speed4-16
 Adjusting trim angle.....3-17
- B**
 Basic boating rules1-7
 Battery care.....4-8
 Battery requirement1-14
 Breaking in (running in) engine.....3-4
- C**
 Changing engine oil4-17
 Changing gear oil.....4-24
 Checking battery4-26
 Checking bolts and nuts.....4-29
 Cleaning cooling-water passages4-29
 Cleaning the outboard motor4-30
 Checking fuel system4-14
 Checking painted surface of motor.....4-30
 Checking power trim and tilt system...4-21
 Checking propeller.....4-22
 Checking the engine oil level.....3-6
 Checking timing belt.....4-19
 Checking wiring and connectors.....4-20
 Cleaning and adjusting spark plug4-12
 Cleaning and anti-corrosion measure ...4-7
 Coating the boat bottom.....4-30
 Connecting the battery.....4-28
 Cruising in other conditions3-24
 Cruising in salt water.....3-24
 Cruising in shallow water3-23
 Cruising in turbid water3-24
- D**
 Disconnecting the battery4-28
- E**
 Emergency starting engine.....5-7
 Emission control information.....1-2
 Engine stop button2-5
 Engine stop lanyard switch2-4, 2-8
 Engine oil.....1-13
- Exhaust leakage4-20
- F**
 Filling fuel3-7
 Flushing cooling system and fogging engine4-5
 Flushing device2-14
 Forward.....3-13
 Fueling instructions1-11
- G**
 Gasoline.....1-12
 Gear shift lever.....2-2
 Greasing.....4-11
- I**
 Identification numbers records1-1
 Impact damage5-5
 Important labels1-6
 Inspecting fuel filter4-15
 Inspecting and replacing anode(s).....4-25
 Installation3-1
- K**
 Key number1-1
- L**
 Lubrication.....4-7
 Low oil pressure warning2-16
 Low oil pressure warning lamp.....2-12
- M**
 Main components.....2-1
 Main switch2-7
 Maintenance chart4-10
 Motor exterior4-30
 Mounting height3-3
 Mounting the outboard motor3-2
 Multifunction tiller handle.....2-2
- N**
 Neutral interlock trigger2-6
 Neutral throttle lever2-7
- O**
 Operations of controls and other functions2-2
 Outboard motor serial number1-1
 Overheat warning2-15

Overheat warning lamp	2-12	Treatment of submerged motor	5-9
P		Trim meter	2-12
Periodic maintenance	4-9	Trim tab	2-10
Power trim/tilt switch	2-9, 2-11	Trimming outboard motor	3-16
Power trim/tilt will not operate	5-5	Troubleshooting	5-1
Pre-operation checks	3-5	W	
Propeller selection	1-15	Warming up engine	3-12
R		Warning indicators	2-11
Recoil starter handle	2-2	Warning system	2-15
Remote control	2-5	Water leakage	4-20
Remote control lever	2-6	Warranty information	Next page
Replacement parts	4-9		
Replacing fuse	4-20		
Reverse	3-14		
Ring free fuel additive	3-7		
S			
Safety information	1-4		
Shifting	3-13		
Specifications	4-1		
Star labels	1-3		
Start-in-gear protection	1-16		
Starter will not operate	5-6		
Starting engine	3-8		
Steering friction adjusting lever	2-5		
Stopping engine	3-15		
Storing outboard motor	4-4		
T			
Tachometer	2-12		
Temporary action in emergency	5-5		
Throttle control grip	2-3		
Throttle friction adjusting knob	2-3		
Throttle friction adjusting screw	2-9		
Throttle indicator	2-3		
Tiller handle	2-2		
Tilting up/down	3-20		
Tilt lock mechanism	2-13		
Tilt support knob	2-13		
Top cowling lock lever	2-13		
Trailing outboard motor	4-3		
Transporting and storing outboard motor	4-3		

IMPORTANT WARRANTY INFORMATION FOR U.S.A. AND CANADA

Welcome to the Yamaha Family!

Congratulations on the purchase of your new Yamaha marine power. Yamaha is committed to exceptional customer satisfaction, and we want your ownership experience to be a satisfying one. Please read the following warranty information to help ensure satisfaction with your Yamaha.

Yamaha is ready to stand behind your purchase with strong warranty coverage. To be sure you receive all the benefits of warranty, please take the following steps:

1. Be sure your new Yamaha is registered for warranty. Your boat dealer should do this at the time of sale. Make sure your dealer gives you a copy of the completed Yamaha registration card for your records. If you are unsure whether or not your Yamaha is registered, complete the Warranty Registration card found inside the cover of the Owner's Manual. Mail it to the distributor for the country in which you live (see step 6 for the correct address). If your Yamaha is not properly registered, a warranty repair could be unnecessarily delayed while registration records are checked.
2. Read the Limited Warranty statement which follows these instructions. This warranty applies to Yamaha outboard motors sold in the United States, whether purchased separately or when supplied as original equipment by a boat builder. The terms also apply to original equipment packages sold in Canada, with coverage provided by Yamaha Motor Canada (see "Warranty Guide" for Canadian models). This warranty explains the conditions of the warranty, including the obligations that your dealer and you as the owner have under the warranty. For example, your Yamaha outboard must receive a proper pre-delivery inspection (PDI) by the selling dealer. Failure to take this important step could jeopardize warranty coverage!
3. If you need warranty repairs, you must take your Yamaha outboard to an authorized Yamaha outboard dealer. Be aware that not all selling boat dealers are authorized Yamaha dealers. Only authorized dealers have the factory training, special tools, and Yamaha support needed to perform warranty repairs.
4. If you are away from home, or your selling dealer is not an authorized Yamaha dealer, use the following toll-free numbers to find the nearest Yamaha dealer.

United States Dealer Locations: 1-800-692-6242

Canada Dealer Locations: 1-800-267-8577

5. Your warranty applies specifically to repairs made in the country of purchase. If your U.S.-purchased Yamaha needs warranty service while in Canada, or your Canadian purchased Yamaha needs service while in the United States, Yamaha will assist the local dealer whenever possible. However, some products available in one country may not be sold or serviced in the other.
6. If you need any additional information about your Yamaha or warranty coverage which your dealer cannot provide, please contact us directly.

Yamaha Motor Corporation, U.S.A.
P.O. Box 6555
Cypress, CA 90630
Attention: Customer Relations Department

Telephone No. (714) 761-7439
Fax No. (714) 761-7559

Yamaha Motor Canada Ltd.
480 Gordon Baker Road
Toronto, Ontario
M2H 3B4
Attention: Customer Relations Department

Telephone No. (416) 498-1911
Fax No. (416) 491-3122

YAMAHA MOTOR CORPORATION, U.S.A.

FOUR-STROKE OUTBOARD MOTOR

THREE-YEAR LIMITED WARRANTY

Yamaha Motor Corporation, U.S.A. hereby warrants that new Yamaha 1999-or-later model four-stroke outboard motors originally distributed by Yamaha Motor Corporation, U.S.A. will be free from defects in material and workmanship for the period of time stated herein, subject to certain stated limitations. Warranty coverage for outboards distributed by non-US Yamaha affiliated companies may be different.

PERIOD OF WARRANTY. Any new Yamaha 1999-or-later model four-stroke outboard motor purchased and registered with Yamaha Motor Corporation, U.S.A. for pleasure use in the United States, will be warranted against defects in material or workmanship for a period of three (3) years from the date of purchase, subject to exclusions noted herein. Any Yamaha outboard motor purchased and utilized for commercial applications will be warranted for a period of one (1) year from the date of purchase, subject to exclusions noted herein. Yamaha peripheral equipment included with the motor, such as gauges, fuel tanks, and hoses, remote control boxes, and wiring external from the motor unit, will be warranted for one (1) year from the date of purchase of either pleasure or commercial use. Replacement parts used in warranty repairs will be warranted for the balance of the applicable warranty period.

The second and third year of warranty (if applicable) shall be limited to covering the cost of parts and labor for major components only. The major components covered are:

Power Unit Section

- Power Head
- Intake Manifold
- Carburetor Assembly and its Related Components
- Fuel Injection System and its Related Components
- Fuel and Oil Pump Assemblies
- Ignition System (Standard and Microcomputer)

Lower Unit Section

- Exhaust System
- Upper Casing
- Lower Unit Assembly

Bracket Section

- Bracket System
- Power Trim and Tilt Assembly

WARRANTY REGISTRATION. To be eligible for warranty coverage, the outboard motor must be registered with Yamaha Motor Corporation, U.S.A. Warranty registration can be accomplished by any authorized Yamaha Outboard Motor Dealer. Upon receipt of the registration, an Owner's Warranty Card will be sent by Yamaha to the registered purchaser.

OBTAINING REPAIRS UNDER WARRANTY. To receive repairs under this warranty, a valid Owner's Warranty Card must be presented to an authorized Yamaha Outboard Motor Dealer.

During the period of warranty, any authorized Yamaha outboard dealer will, free of charge, repair or replace, at Yamaha's option, any parts adjudged defective by Yamaha due to faulty workmanship or material from the factory. All replaced parts will become the property of Yamaha Motor Corporation, U.S.A.

CUSTOMER'S RESPONSIBILITY. Under the terms of this warranty, the customer will be responsible for ensuring that the outboard motor is properly operated, maintained, and stored as specified in the applicable Owner's Manual.

The owner of the outboard motor shall give notice to an authorized Yamaha Outboard Motor Dealer of any and all apparent defects within ten (10) days of discovery and make the motor available at that time for inspection and repairs at the dealer's place of business.

GENERAL EXCLUSIONS FROM WARRANTY. This warranty will not cover the repair of damage if the damage is a result of abuse or neglect of the product. Examples of abuse and neglect include, but are not limited to:

1. Racing or competition use, modification of original parts, abnormal strain.
2. Lack of proper maintenance and off season storage as described in the Owner's Manual, installation of parts or accessories that are not equivalent in design and quality genuine Yamaha parts.
3. Operation of the motor at an rpm other than specified, use of lubricants or oils that are not suitable for outboard motor use.
4. Damage as a result of accidents, collisions, contact with foreign materials, or submersion.
5. Growth of marine organism on motor surfaces.
6. Normal deterioration.

SPECIFIC PARTS EXCLUDED FROM WARRANTY. Parts replaced due to normal wear or routine maintenance such as oil, spark plugs, shear pins, propellers, hubs, fuel and oil filters, brushes for the starter motor and power tilt motor, water pump impellers, and anodes, are not covered by warranty.

Charges for removal of the motor from a boat and transporting the motor to and from an authorized Yamaha Outboard Motor Dealer are excluded from warranty coverage.

Specific parts excluded from the second and third year of warranty (if applicable) are:

- Top and Bottom Cowling
- Electric Components (other than ignition system)
- Rubber Components (such as hoses, tubes, rubber seals, fittings, and clamps)

TRANSFER OF WARRANTY. Transfer of the warranty from the original purchaser to any subsequent purchaser is possible by having the motor inspected by an authorized Yamaha Outboard Motor Dealer and requesting the dealer to submit a change of registration to Yamaha Motor Corporation, U.S.A. within ten (10) days of the transfer.

YAMAHA MOTOR CORPORATION, U.S.A. MAKES NO OTHER WARRANTY OF ANY KIND, EXPRESSED OR IMPLIED. ALL IMPLIED WARRANTIES OF MERCHANTABILITY AND FITNESS FOR A PARTICULAR PURPOSE WHICH EXCEED THE OBLIGATIONS AND TIME LIMITS STATED IN THIS WARRANTY ARE HEREBY DISCLAIMED BY YAMAHA MOTOR CORPORATION, U.S.A. AND EXCLUDED FROM THIS WARRANTY.

SOME STATES DO NOT ALLOW LIMITATIONS ON HOW LONG AN IMPLIED WARRANTY LASTS, SO THE ABOVE LIMITATIONS MAY NOT APPLY TO YOU. ALSO EXCLUDED FROM THIS WARRANTY ARE ANY INCIDENTAL OR CONSEQUENTIAL DAMAGES INCLUDING LOSS OF USE. SOME STATES DO NOT ALLOW THE EXCLUSION OR LIMITATION OF INCIDENTAL OR CONSEQUENTIAL DAMAGES, SO THE ABOVE EXCLUSION MAY NOT APPLY TO YOU.

THIS WARRANTY GIVES YOU SPECIFIC LEGAL RIGHTS, AND YOU MAY ALSO HAVE OTHER RIGHTS WHICH VARY FROM STATE TO STATE.

YAMAHA MOTOR CORPORATION, U.S.A.
Post Office Box 6555
Cypress, California 90630

WARRANTY QUESTIONS AND ANSWERS

- Q. What costs are my responsibility during the warranty period?
A. The customer's responsibility includes all costs of normal maintenance services, non-warranty repairs, accident and collision damages.
- Q. What are some examples of "abnormal" strain, neglect, or abuse?
A. These terms are general and overlap each other in areas. Specific examples include:
Running the machine out of oil, operating the machine with a broken or damaged part which causes another part to fail, damage or failure due to improper or careless transportation, and/or tie down. If you have any specific questions on operation or maintenance, please contact your Yamaha outboard dealer for advice.
- Q. Does the warranty cover incidental costs such as towing or transportation due to a failure?
A. No. The warranty is limited to repair of the machine itself.
- Q. May I perform any or all of the recommended maintenance shown in the Owner's Manual instead of having the dealer do them?
A. Yes, if you are a qualified mechanic and follow the procedures specified in the Owner's and Service Manuals. We do recommend, however, that items requiring special tools or equipment be done by a Yamaha outboard dealer.
- Q. Will the warranty be void or canceled if I do not operate or maintain my new outboard exactly as specified in the Owner's Manual?
A. No. The warranty on a new outboard cannot be "voided" or "canceled". However, if a particular failure is caused by operation or maintenance other than as shown in the Owner's Manual, that failure may not be covered under warranty.
- Q. What responsibility does a Yamaha outboard dealer have under this warranty?
A. Each Yamaha outboard dealer is expected to:
1. Completely set up each outboard he sells prior to delivery.
2. Explain the operation, maintenance, and warranty requirements to your satisfaction at the time of sale, and upon your request at any later date.
In addition, each Yamaha outboard dealer is held responsible for his setup, service and warranty repair work.
- Q. Is the warranty transferable to second owners?
A. Yes. The remainder of any existing warranty can be transferred upon request. The unit has to be inspected and re-registered by an authorized Yamaha outboard dealer for the policy to remain effective.

CUSTOMER SERVICE

If your machine requires warranty service, you must take it to any authorized Yamaha outboard dealer within the continental United States. Be sure to bring your warranty registration identification or other valid proof of the original date of purchase. If a question or problem arises regarding warranty, first contact the owner of the dealership. Since all warranty matters are handled at the dealer level, this person is in the best position to help you. If you are still not satisfied and require additional assistance, please write:

YAMAHA MOTOR CORPORATION U.S.A.
CUSTOMER RELATIONS DEPARTMENT
P.O.Box 6555
Cypress, California 90630

When contacting Yamaha Motor Corporation, U.S.A. don't forget to include any important information such as names, addresses, model, engine serial number, dates, and receipts.

CHANGE OF ADDRESS

The federal government requires each manufacturer of a motor vehicle to maintain a complete, up-to-date list of all first purchasers against the possibility of a safety-related defect and recall. This list is compiled from the purchase registrations sent to Yamaha Motor Corporation, U.S.A. by the selling dealer at the time of your purchase.

If you should move after you have purchased your new outboard, please advise us of your new address by sending a postcard listing your outboard model name, engine serial number, dealer number (or dealer's name) as it is shown on your warranty identification, your name and new mailing address. Mail to:

YAMAHA MOTOR CORPORATION, U.S.A.
WARRANTY DEPARTMENT
P.O.Box 6555
Cypress, California 90630

This will ensure that Yamaha Motor Corporation, U.S.A. has an up-to-date registration record in accordance with federal law.

IMPORTANT WARRANTY INFORMATION IF YOU USE YOUR YAMAHA OUTSIDE U.S.A. OR CANADA

Welcome to the Yamaha Family!

Congratulations on the purchase of your new Yamaha marine power. Yamaha is committed to exceptional customer satisfaction, and we want your ownership experience to be a satisfying one. Please read the following warranty information to help ensure satisfaction with your Yamaha.

This model was manufactured as a U.S.A. specification model, and the warranty statement shown in this manual is for market. To receive the benefits of the warranty that applies to the country in which you use your Yamaha, please note the following information.

1. The warranty on this model is the same as equivalent models sold in the country where you will receive service. If you need more information about your warranty coverage or your Yamaha outside the U.S.A. or Canada, please contact an authorized Yamaha dealer in your country.
2. Keep a copy of your sales contract or invoice for the purchase of your Yamaha and present it if you need warranty repairs. This document should show the date of purchase, which is important evidence the repairing dealer will need to be sure your Yamaha is covered by warranty.
3. If your Yamaha needs warranty repairs, contact an authorized Yamaha dealer in the country where you are. He will explain how to get warranty service in that country.
4. This Yamaha model may not be sold in some countries. Therefore, in some cases your local dealer may not have all the parts or service information he may need, which may unavoidably delay repairs. If this happens, we thank you for your understanding and assure you we will attempt to resolve the situation as quickly as possible.



YAMAHA MOTOR CORPORATION, USA

Printed in Japan

April 2002-0.7 × 1 

67C-28199-13

(F30AET, F40BMHD, F40BED, F40BET)

(E)

YAMAHA

OUTBOARD MOTOR WARRANTY REGISTRATION ENREGISTREMENT DE LA GARANTIE DU MOTEUR HORS-BORD

Please complete and mail this card. This information is necessary to accurately register your unit for warranty.
Veuillez signer ci-dessous pour attester que le montage et l'inspection ont été faits dans le respect des directives d'inspection et que la marche à suivre pour la garantie et l'entretien a été expliquée à l'acheteur au détail.

OUTBOARD MOTOR MODEL AND SERIAL NUMBER (From I.D. label on clamp bracket)
MODÈLE ET NO. DE SÉRIE DU MOTEUR HORS-BORD (sur l'étiquette d'identification de la presse de fixation)

YAMAHA

**YAMAHA MOTOR CO., LTD.
MADE IN JAPAN
PAYS D'ORIGINE JAPON**



(For Dealer Use Only)
(A l'usage du concessionnaire)
YAMAHA DEALER NUMBER
NO. DU CONCESSIONNAIRE
YAMAHA

DEALER NAME
NOM DU
CONCESSIONNAIRE

DATE SOLD
DATE DE
LIVRAISON

_____|_____|_____|_____

MONTH
MOIS

DAY
JOUR

YEAR
ANNÉE

OWNER'S NAME
NOM DU
PROPRIÉTAIRE

ADDRESS
ADRESSE

STREET
RUE

PHONE NUMBER ()
NUMÉRO DE TÉLÉPHONE

CITY
VILLE

STATE/PROVINCE
PROVINCE

ZIP
CODE POSTAL

USAGE
(Check One)
UTILISATION
(En cocher un.)

PLEASURE
LOISIR
 COMMERCIAL
COMMERCIAL

PLACE
POSTAGE
HERE

ATTN: WARRANTY DEPARTMENT