

**NOTE:** The following applies to CE marked products only.

## Declaration of Conformance – Mercury MerCruiser

This sterndrive or inboard engine when installed in accordance to Mercury MerCruisers' instructions complies with the requirements of the following directives by meeting the associated standards, as amended:

Recreational Craft Directive 94/25/EC; 2003/44/EC

Applicable Requirement	Standards Applied
Owner's manual (A.2.5)	ISO 10240
Openings in Hull, Deck and superstructure (A.3.4)	ISO 9093-1; ISO 9093-2
Handling characteristics (A.4)	ISO 8665
Inboard Engine (A.5.1.1)	ISO 15584; ISO 10088; ISO 7840; ISO 10133
Fuel System (A.5.2)	ISO 10088; ISO 7840; ISO 8469
Electrical System (A.5.3)	ISO 10133; ISO 8846
Steering system (A.5.4)	Applicable portions of: ISO 10592, ISO 8848 and ABYC P-17
Exhaust emission requirements (B.2)	ISO 8178
Owner's manual (B.4)	ISO 8665
Noise emission levels (C.1)	ISO 14509
Ignition-protected equipment (Annex II)	ISO 8846; SAE J1171; SAE J1191; SAE J 2031

Mercury MerCruiser declares that our sterndrive or inboard engines without integral exhaust, when installed in a recreational craft, in accordance with the manufacturers supplied instructions, will meet the exhaust emissions requirements of the directive mentioned above. This engine must not be put into service until the recreational craft in which it is to be installed has been declared in conformity, if so required, with the relevant provision of the directive.

Electromagnetic Compatibility Directive 89/336/EC, 92/31/EEC and 93/68/EEC

Generic emission standard	EN 50081-1
Generic immunity standard	EN 50082-1
Vehicles, boats and internal combustion engine driven devices - Radio disturbance characteristics	SAE J551 (CISPR 12)
Electrostatic discharge testing	EN 61000-6-2; EN 61000-4-2; EN61000-4-3

The notified body responsible for surveillance of the quality system under Full Quality Assurance Module H of Directive 2003/44/EC is:

Det Norske Veritas  
Norway  
Notified Body Number: 0575

This declaration is issued under the sole responsibility of Mercury Marine and Mercury MerCruiser.



Patrick C. Mackey

President - Mercury Marine, Fond du Lac, WI USA

Regulatory contact:  
 Engineering - Regulatory  
 MerCruiser  
 3003 N. Perkins Rd  
 Stillwater, Oklahoma 74075  
 USA  
 (405) 377-1200

## Identification Record

Please record the following information:

Engine Model and Horsepower		Engine Serial Number
Transom Assembly Serial Number (Sterndrive)	Gear Ratio	Sterndrive Unit Serial Number
Transmission Model (Inboard)	Gear Ratio	Transmission Serial Number
Propeller Number	Pitch	Diameter
Hull Identification Number (HIN)		Purchase Date
Boat Manufacturer	Boat Model	Length
Exhaust Gas Emissions Certification Number		

The serial numbers are the manufacturer's keys to numerous engineering details that apply to your Mercury MerCruiser® power package. When contacting your Authorized Mercury MerCruiser Dealer about service, **always specify model and serial numbers.**

The description and specifications contained herein were in effect at the time this guide was approved for printing. Mercury Marine, whose policy is one of continuous improvement, reserves the right to discontinue models at any time, or to change specifications or designs, without notice and without incurring obligation.

Mercury Marine, Fond du Lac, Wisconsin, U.S.A. Printed in U.S.A.

©2005, Mercury Marine

Mercury, Mercury Marine, MerCruiser, Mercury MerCruiser, Mercury Racing, Mercury Precision Parts, Mercury Propellers, Mariner, Quicksilver, #1 On The Water, Alpha, Bravo, Pro Max, OptiMax, Sport-Jet, K-Planes, MerCathode, RideGuide, SmartCraft, Zero Effort, M with Waves logo, Mercury with Waves logo, and SmartCraft logo are all registered trademarks of Brunswick Corporation. Mercury Product Protection logo is a registered service mark of Brunswick Corporation.

## Welcome

You have selected one of the finest marine power packages available. It incorporates numerous design features to assure operating ease and durability.

With proper care and maintenance, you will thoroughly enjoy using this product for many boating seasons. To ensure maximum performance and carefree use, we ask that you thoroughly read this manual.

The Operation, Maintenance and Warranty Manual contains specific instructions for using and maintaining your product. We suggest that this manual remain with the product for ready reference whenever you are on the water.

Thank you for purchasing one of our Mercury MerCruiser products. We sincerely hope your boating will be pleasant!

Mercury MerCruiser

## Warranty Message

The product you have purchased comes with a **limited warranty** from Mercury Marine; the terms of the warranty are set forth in the Warranty Sections of this manual. The warranty statement contains a description of what is covered, what is not covered, the duration of coverage, how to best obtain warranty coverage, **important disclaimers and limitations of damages** and other related information. Please review this important information.

Mercury Marine products are designed and manufactured to comply with our own high quality standards, applicable industry standards and regulations, as well as certain emissions regulations. At Mercury Marine every engine is operated and tested before it is boxed for shipment to make sure that the product is ready for use. In addition, certain Mercury Marine products are tested in a controlled and monitored environment, for up to 10 hours of engine run time, in order to verify and make a record of compliance with applicable standards and regulations. All Mercury Marine product, sold as new, receives the applicable limited warranty coverage, whether the engine participated in one of the test programs described above or not.

## Read This Manual Thoroughly

**IMPORTANT:** If you don't understand any portion of this manual, contact your dealer for a demonstration of actual starting and operating procedures.

## Notice

Throughout this publication, and on your power package, **WARNINGS** and **CAUTIONS**, accompanied by the International Hazard Symbol , may be used to alert the installer/user to special instructions concerning a particular service or operation that may be hazardous if performed incorrectly or carelessly. **Observe them carefully.**

These Safety Alerts alone cannot eliminate the hazards that they signal. Strict compliance with these special instructions while performing the service, plus common sense operation, are major accident prevention measures.

### **WARNING**

**WARNING** - indicates a potentially hazardous situation that, if not avoided, could result in death or serious injury.

### **CAUTION**

**CAUTION** - indicates a potentially hazardous situation that, if not avoided, may result in minor or moderate injury or property damage. It may also be used to alert against unsafe practices.

**IMPORTANT:** Indicates information or instructions that are necessary for proper operation and/or maintenance.

**⚠ WARNING**

The operator (driver) is responsible for the correct and safe operation of the boat, the equipment aboard and the safety of all occupants aboard. We strongly recommend that the operator read this Operation, Maintenance and Warranty Manual and thoroughly understand the operational instructions for the power package and all related accessories before the boat is used.

**⚠ WARNING**

**California Proposition 65 Warning**

The engine exhaust from this product contains chemicals known to the state of California to cause cancer, birth defects or other reproductive harm.

# TABLE OF CONTENTS

---

## Section 1 - Warranty

---

Transfer Of Warranty.....	2	Mercury MerCruiser Limited Warranty (Confederation of Independent States, Middle-East, and Africa.....	5
Warranty Registration United States And Canada. .	2	3 Year Limited Warranty Against Corrosion (Worldwide).....	6
Warranty Registration Outside The United States And Canada.....	2	Warranty Coverage And Exclusions.....	7
Mercury, MerCruiser Limited Warranty United States, Canada and Europe (Gasoline Fueled Products Only).....	3	General Exclusions From Warranty.....	8

---

## Section 2 - Getting to Know Your Power Package

---

Lanyard Stop Switch.....	12	Console Mount Features- Dual Engine.....	20
Instrumentation.....	13	Synchronizing Dual Engines.....	20
System View.....	13	Dual Helm Station Transfer.....	21
Digital Gauges.....	14	Synchronizing Dual Helms Prior To Station Transfer.....	22
Analog Gauges.....	14	Zero Effort Features.....	22
Remote Controls (Non-DTS Models).....	15	Electrical System Overload Protection.....	22
Remote Controls.....	15	Audio Warning System.....	24
Panel Mount Features.....	15	Testing The Audio Warning System.....	24
Console Mount Features.....	16	Engine Guardian Strategy.....	24
Zero Effort Features.....	16	Transmission Guardian Strategy.....	25
Remote Controls (DTS Models).....	17	Warning Horn Signals.....	25
Remote Controls.....	17	Emissions Information.....	25
Panel Mount Features.....	17	Emission Control Information Label.....	25
Console Mount Features - Single Engine.....	18	Owner Responsibility.....	26
Slim Binnacle Console Mount Features - Single Engine.....	19	Star Label.....	26

---

## Section 3 - On The Water

---

Safe Boating Suggestions.....	30	Starting and Stopping the Engine.....	35
Be Alert To Carbon Monoxide Poisoning.....	31	Starting the Engine.....	35
Good Ventilation.....	32	Stopping the Engine.....	36
Poor Ventilation .....	32	Throttle Only Operation.....	37
Basic Boat Operation (Non-DTS Models).....	32	Freezing Temperature Operation.....	37
Launching and Boat Operation.....	32	Drain Plug and Bilge Pump.....	37
Operation Chart.....	33	Protecting People In The Water.....	38
Starting and Stopping the Engine.....	33	While You Are Cruising.....	38
Starting the Engine.....	33	While Boat Is Stationary.....	38
Stopping the Engine.....	34	High-Speed And High-Performance Boat Operation.....	38
Throttle Only Operation.....	34	Passenger Safety In Pontoon Boats And Deck Boats.....	38
Freezing Temperature Operation.....	34	Boats Having An Open Front Deck.....	38
Drain Plug and Bilge Pump.....	34	Boats With Front-Mounted, Raised Pedestal Fishing Seats.....	39
Basic Boat Operation (DTS Models).....	35		
Launching and Boat Operation.....	35		
Operation Chart.....	35		

---

Wave And Wake Jumping.....	39	Ventilation.....	41
Impact With Underwater Hazards.....	40	Elevation And Climate.....	41
Conditions Affecting Operation.....	41	Getting Started.....	42
Weight Distribution (Passengers and Gear)		20-Hour Break-In Period.....	42
Inside the Boat.....	41	After Break-In Period.....	42
Bottom Of Boat.....	41	End of First Season Checkup.....	42
Cavitation.....	41		

## Section 4 - Specifications

Cruising RPM.....	44	Engine Specifications.....	46
Fuel Requirements.....	44	Tow Sports Models.....	46
Fuel Ratings.....	44	Inboard Models.....	47
Using Reformulated (Oxygenated) Gasolines		Fluid Specifications.....	47
(USA Only).....	44	Engine.....	47
Gasolines Containing Alcohol.....	44	Transmission.....	48
Engine Oil.....	45		

## Section 5 - Maintenance

Owner/Operator Responsibilities.....	50	Checking While the Engine is Warm.....	57
Dealer Responsibilities.....	50	Checking While Engine is Cold.....	57
Maintenance.....	50	Changing.....	57
Do It Yourself Maintenance Suggestions.....	51	Engine Coolant.....	57
Inspection.....	51	Checking.....	57
Maintenance Schedule - Inboard Models.....	52	Filling.....	58
Routine Maintenance.....	52	Changing.....	59
Each Day Start.....	52	Cleaning The Flame Arrestor.....	59
Each Day End.....	52	Positive Crankcase Ventilation Valve (PCV)...	60
Weekly.....	52	Changing.....	60
Every Two Months or 50 Hours.....	52	Changing Water Separating Fuel Filter.....	61
Scheduled Maintenance.....	52	GEN II Models.....	61
Every 100 Hours or Annually (Whichever		GEN III Models.....	62
Occurs First).....	52	In-line Fuel Filter.....	64
Every 300 Hours or 3 Years.....	52	Lubrication.....	66
Every 5 Years.....	53	Throttle Cable.....	66
Maintenance Log.....	53	Transmission Linkage.....	66
Engine Oil.....	53	Serpentine Drive Belt.....	67
Checking.....	53	Checking.....	67
Filling.....	54	Replacing Belt and/or Adjusting Tension.....	68
Changing Oil and Filter.....	55	Flushing The Power Package.....	69
Easy Engine Oil Drain System.....	55	Inboards.....	69
Engine Oil Drain Pump.....	55	Tow Sports.....	70
Changing Filter.....	56	Battery.....	72
Transmission Fluid.....	57	Multiple EFI Engine Battery Precautions.....	73

## Section 6 - Storage

Cold Weather or Extended Storage.....	76
---------------------------------------	----

Preparing Power Package for Storage.....	76	Boat in the Water.....	78
Engine and Fuel System Preparation.....	77	Boat out of the Water.....	80
Draining the Seawater System.....	77	Three Point Manual Drain System.....	82
Drain System Identification.....	78	Boat in the Water.....	82
Air Actuated Single Point Drain System.....	78	Boat out of the Water.....	84
Three Point Manual Drain System.....	78	Battery Storage.....	84
Air Actuated Single Point Drain System.....	78	Power Package Recommissioning.....	84

## Section 7 - Troubleshooting

Diagnosing EFI Problems.....	88	Excessive Engine Temperature.....	89
Diagnosing DTS Problems.....	88	Insufficient Engine Temperature.....	90
Engine Guardian System.....	88	Low Engine Oil Pressure.....	90
Starter Motor Will Not Crank Engine, Or Cranks Slow.....	88	Battery Will Not Come Up On Charge.....	90
Engine Will Not Start Or Is Hard To Start.....	88	Remote Control Operates Hard, Binds, Has	
Engine Runs Rough, Misses And/Or Backfires.....	89	Excessive Free-play Or Makes Unusual Sounds..	90
Poor Performance.....	89	Steering Wheel Turns Hard Or Jerky.....	90

## Section 8 - Customer Assistance Information

Owner Service Assistance.....	92	Parts And Accessories Inquiries.....	93
Local Repair Service.....	92	Resolving A Problem.....	93
Service Away From Home.....	92	Mercury Marine Service Offices.....	93
Stolen Power Package.....	92	Ordering Literature.....	94
Attention Required After Submersion.....	92	United States and Canada.....	94
Replacement Service Parts.....	92	Outside The United States and Canada.....	94





# Section 1 - Warranty

1

## Table of Contents

Transfer Of Warranty.....	2	Mercury MerCruiser Limited Warranty	
Warranty Registration United States And Canada		(Confederation of Independent States, Middle-East,	
.....	2	and Africa.....	5
Warranty Registration Outside The United States		3 Year Limited Warranty Against Corrosion	
And Canada.....	2	(Worldwide).....	6
Mercury, MerCruiser Limited Warranty United		Warranty Coverage And Exclusions.....	7
States, Canada and Europe (Gasoline Fueled		General Exclusions From Warranty .....	8
Products Only).....	3		

## Transfer Of Warranty

The limited warranty is transferable to a subsequent purchaser, but only for the remainder of the unused portion of the limited warranty. This will not apply to products used for commercial applications.

To transfer the warranty to the subsequent owner, send or fax a copy of the bill of sale or purchase agreement, new owner's name, address and engine serial number to Mercury Marine's warranty registration department. In the United States and Canada, mail to:

Mercury Marine  
Attn: Warranty Registration Department  
W6250 W. Pioneer Road  
P.O. Box 1939  
Fond du Lac, WI 54936-1939  
920-929-5054  
Fax 920-929-5893

Upon processing the transfer of warranty, Mercury Marine will send registration verification to the new owner of the product by mail.

There is no charge for this service.

For products purchased outside the United States and Canada, contact the distributor in your country, or the Marine Power Service Center closest to you.

## Warranty Registration United States And Canada

1. You may change your address at any time, including at time of warranty claim, by calling Mercury Marine or sending a letter or fax with your name, old address, new address, and engine serial number to Mercury Marine's warranty registration department. Your dealer can also process this change of information.

Mercury Marine  
Attn: Warranty Registration Department  
W6250 Pioneer Road  
P.O. Box 1939  
Fond du Lac, WI 54936-1939  
920-929-5054  
Fax 920-929-5893

***NOTE: Registration lists must be maintained by Mercury Marine and any dealer on marine products sold in the United States, should a safety recall notification under the Federal Safety Act be required.***

2. To be eligible for warranty coverage, the product must be registered with Mercury Marine. At the time of sale, the dealer should complete the warranty registration and immediately submit it to Mercury Marine via MercNET, E-mail, or mail. Upon receipt of this warranty registration, Mercury Marine will record the registration.
3. Upon processing the warranty registration, Mercury Marine will send registration verification by mail to the purchaser of the product. If this registration verification is not received within 30 days, please contact your selling dealer immediately. Warranty coverage is not effective until your product is registered with Mercury Marine.

## Warranty Registration Outside The United States And Canada

1. It is important that your selling dealer fills out the Warranty Registration Card completely and mails it to the distributor or Marine Power Service Center responsible for administering the warranty registration/claim program for your area.

2. The Warranty Registration Card identifies your name and address, product model and serial numbers, date of sale, type of use and the selling distributor's/dealer's code number, name and address. The distributor/dealer also certifies that you are the original purchaser and user of the product.
3. A copy of the Warranty Registration Card, designated as the Purchaser's Copy, MUST be given to you immediately after the card has been completely filled out by the selling distributor/dealer. This card represents your factory registration identification, and should be retained by you for future use when required. Should you ever require warranty service on this product, your dealer may ask you for the Warranty Registration Card to verify date of purchase and to use the information on the card to prepare the warranty claim forms.
4. In some countries, the Marine Power Service Center will issue you a permanent (plastic) Warranty Registration Card within 30 days after receiving the Factory Copy of the Warranty Registration Card from your distributor/dealer. If you receive a plastic Warranty Registration Card, you may discard the Purchaser's Copy that you received from the distributor/dealer when you purchased the product. Ask your distributor/dealer if this plastic card program applies to you.

**IMPORTANT: Registration lists must be maintained by the factory and dealer in some countries by law. It is our desire to have ALL products registered at the factory should it ever be necessary to contact you. Make sure your dealer/distributor fills out the warranty registration card immediately and sends the factory copy to the Marine Power International Service Center for your area.**

5. For further information concerning the Warranty Registration Card and its relationship to Warranty Claim processing, refer to the International Warranty.

## Mercury, MerCruiser Limited Warranty United States, Canada and Europe (Gasoline Fueled Products Only)

**WHAT IS COVERED:** Mercury Marine warrants its new products to be free of defects in material and workmanship during the period described below.

**DURATION OF COVERAGE:** This Limited Warranty provides coverage for either two (2) years from the date the product is first sold to a recreational use retail purchaser, or the date on which the product is first put into service, whichever occurs first. Commercial users of these products receive warranty coverage of either one (1) year from the date of first retail sale, or the accumulation of 500 hours of operation, whichever occurs first. Commercial use is defined as any work or employment related use of the product, or any use of the product which generates income, for any part of the warranty period, even if the product is only occasionally used for such purposes. The repair or replacement of parts, or the performance of service under this warranty, does not extend the life of this warranty beyond its original expiration date. Unexpired warranty coverage can be transferred from one recreational use customer to a subsequent recreational use customer upon proper re-registration of the product. Unexpired warrant coverage cannot be transferred either to or from a commercial use customer.

**CONDITIONS THAT MUST BE MET IN ORDER TO OBTAIN WARRANTY COVERAGE:**

Warranty coverage is available only to retail customers that purchase from a Dealer authorized by Mercury Marine to distribute the product in the country in which the sale occurred, and then only after the Mercury Marine specified pre-delivery inspection process is completed and documented. Warranty coverage becomes available upon proper registration of the product by the authorized dealer. Routine maintenance outlined in the Operation and Maintenance Manual must be timely performed in order to maintain warranty coverage. Mercury Marine reserves the right to make future warranty coverage contingent on proof of proper maintenance.

**WHAT MERCURY WILL DO:** Mercury's sole and exclusive obligation under this warranty is limited to, at our option, repairing a defective part, replacing such part or parts with new or Mercury Marine certified remanufactured parts, or refunding the purchase price of the Mercury product. Mercury reserves the right to improve or modify products from time to time without assuming an obligation to modify products previously manufactured.

**HOW TO OBTAIN WARRANTY COVERAGE:** The customer must provide Mercury with a reasonable opportunity to repair, and reasonable access to the product for warranty service. Warranty claims shall be made by delivering the product for inspection to a Mercury dealer authorized to service the product. If purchaser cannot deliver the product to such a dealer, written notice must be given to Mercury. We will then arrange for the inspection and any covered repair. Purchaser in that case shall pay for all related transportation charges and/or travel time. If the service provided is not covered by this warranty, purchaser shall pay for all related labor and material, and any other expenses associated with that service. Purchaser shall not, unless requested by Mercury, ship the product or parts of the product directly to Mercury. Proof of registered ownership must be presented to the dealer at the time warranty service is requested in order to obtain coverage.

**WHAT IS NOT COVERED:** This limited warranty does not cover routine maintenance items, tune ups, adjustments, normal wear and tear, damage caused by abuse, abnormal use, use of a propeller or gear ratio that does not allow the engine to run in its recommended RPM range (see the Operation and Maintenance Manual), operation of the product in a manner inconsistent with the recommended operation/duty cycle section of the Operation and Maintenance Manual, neglect, accident, submersion, improper installation (proper installation specifications and techniques are set forth in the installation instructions for the product), improper service, use of an accessory or part which damages the Mercury Product and was not manufactured or sold by us, jet pump impellers and liners, operation with fuels, oils or lubricants which are not suitable for use with the product (see the Operation and Maintenance Manual), alteration or removal of parts, or water entering the engine through the fuel intake, air intake or exhaust system, or damage to the product from insufficient cooling water caused by blockage of the cooling system by a foreign body, running the engine out of water, mounting the engine too high on the transom, or running the boat with the engine trimmed out too far.. Use of the product for racing or other competitive activity, or operating with a racing type lower unit, at any point, even by a prior owner of the product, voids the warranty.

Expenses related to haul out, launch, towing, storage, telephone, rental, inconvenience, slip fees, insurance coverage, loan payments, loss of time, loss of income, or any other type of incidental or consequential damages are not covered by this warranty. Also, expenses associated with the removal and/or replacement of boat partitions or material caused by boat design for access to the product are not covered by this warranty.

No individual or entity, including Mercury Marine authorized dealers, has been given authority by Mercury Marine to make any affirmation, representation or warranty regarding the product, other than those contained in this limited warranty, and if made, shall not be enforceable against Mercury Marine.

**DISCLAIMERS AND LIMITATIONS:**

THE IMPLIED WARRANTIES OF MERCHANTABILITY AND FITNESS FOR A PARTICULAR PURPOSE ARE EXPRESSLY DISCLAIMED. TO THE EXTENT THAT THEY CANNOT BE DISCLAIMED, THE IMPLIED WARRANTIES ARE LIMITED IN DURATION TO THE LIFE OF THE EXPRESS WARRANTY. INCIDENTAL AND CONSEQUENTIAL DAMAGES ARE EXCLUDED FROM COVERAGE UNDER THIS WARRANTY. SOME STATES/COUNTRIES DO NOT ALLOW FOR THE DISCLAIMERS, LIMITATIONS AND EXCLUSIONS IDENTIFIED ABOVE, AS A RESULT, THEY MAY NOT APPLY TO YOU. THIS WARRANTY GIVES YOU SPECIFIC LEGAL RIGHTS, AND YOU MAY ALSO HAVE OTHER LEGAL RIGHTS WHICH VARY FROM STATE TO STATE AND COUNTRY TO COUNTRY.

## Mercury MerCruiser Limited Warranty (Confederation of Independent States, Middle-East, and Africa)

**WHAT IS COVERED:** Mercury Marine warrants its products to be free of defects in material and workmanship during the period described below.

**DURATION OF COVERAGE:** This Limited Warranty provides coverage for either one (1) year from the date the product is first sold to a recreational use retail purchaser, or the date on which the product is first put into service, whichever occurs first. Commercial users of these products receive warranty coverage for either one (1) year from the date of first retail sale, or the accumulation of 500 hours of operation, whichever occurs first. Commercial use is defined as any work or employment related use of the product, or any use of the product which generates income, for any part of the warranty period, even if the product is only occasionally used for such purposes. The repair or replacement of parts, or the performance of service under this warranty, does not extend the life of this warranty beyond its original expiration date. Unexpired warranty coverage can be transferred from one recreational use customer to a subsequent recreational use customer upon proper re-registration of the product. Unexpired warranty coverage cannot be transferred either to or from a commercial use customer.

**CONDITIONS THAT MUST BE MET IN ORDER TO OBTAIN WARRANTY COVERAGE:** Warranty coverage is available only to retail customers that purchase from a Dealer authorized by Mercury Marine to distribute the product in the country in which the sale occurred, and then only after the Mercury Marine specified pre-delivery inspection process is completed and documented. Warranty coverage becomes available upon proper registration of the product by the authorized dealer. Routine maintenance outlined in the Operation and Maintenance Manual must be timely performed in order to maintain warranty coverage. Mercury Marine reserves the right to make warranty coverage contingent on proof of proper maintenance.

**WHAT MERCURY WILL DO:** Mercury's sole and exclusive obligation under this warranty is limited to, at our option, repairing a defective part, replacing such part or parts with new or Mercury Marine certified remanufactured parts, or refunding the purchase price of the Mercury product. Mercury reserves the right to improve or modify products from time to time without assuming an obligation to modify products previously manufactured.

**HOW TO OBTAIN WARRANTY COVERAGE:** The customer must provide Mercury with a reasonable opportunity to repair, and reasonable access to the product for warranty service. Warranty claims shall be made by delivering the product for inspection to a Mercury dealer authorized to service the product. If purchaser cannot deliver the product to such a dealer, written notice must be given to Mercury. We will then arrange for the inspection and any covered repair. Purchaser in that case shall pay for all related transportation charges and/or travel time. If the service provided is not covered by this warranty, purchaser shall pay for all related labor and material, and any other expenses associated with that service. Purchaser shall not, unless requested by Mercury, ship the product or parts of the product directly to Mercury. Proof of registered ownership must be presented to the dealer at the time warranty service is requested in order to obtain coverage.

**WHAT IS NOT COVERED:** This limited warranty does not cover routine maintenance items, tune ups, adjustments, normal wear and tear, damage caused by abuse, abnormal use, use of a propeller or gear ratio that does not allow the engine to run in its recommended RPM range (see the Operation and Maintenance Manual), operation of the product in a manner inconsistent with the recommended operation/duty cycle section of the Operation and Maintenance Manual, neglect, accident, submersion, improper installation (proper installation specifications and techniques are set forth in the installation instructions for the product), improper service, use of an accessory or part not manufactured or sold by us, jet pump impellers and liners, operation with fuels, oils or lubricants which are not suitable for use with the product (see the Operation and Maintenance Manual), alteration or removal of parts, or water entering the engine through the fuel intake, air intake or exhaust system, or damage to the product from insufficient cooling water caused by blockage of the cooling system by foreign body, running the engine out of water, mounting the engine too high on the transom, or running the boat with the engine trimmed out too far.

Use of the product for racing or other competitive activity, or operating with a racing type lower unit, at any point, even by a prior owner of the product, voids the warranty.

Expenses related to haul out, launch, towing, storage, telephone, rental, inconvenience, slip fees, insurance coverage, loan payments, loss of time, loss of income, or any other type of incidental or consequential damages are not covered by this warranty. Also, expenses associated with the removal and/or replacement of boat partitions or material caused by boat design for access to the product are not covered by this warranty.

No individual or entity, including Mercury Marine authorized dealers, has been given authority by Mercury Marine to make any affirmation, representation or warranty regarding the product, other than those contained in this limited warranty, and if made, shall not be enforceable against Mercury Marine.

<b>DISCLAIMERS AND LIMITATIONS:</b>
THE IMPLIED WARRANTIES OF MERCHANTABILITY AND FITNESS FOR A PARTICULAR PURPOSE ARE EXPRESSLY DISCLAIMED. TO THE EXTENT THAT THEY CANNOT BE DISCLAIMED, THE IMPLIED WARRANTIES ARE LIMITED IN DURATION TO THE LIFE OF THE EXPRESS WARRANTY. INCIDENTAL AND CONSEQUENTIAL DAMAGES ARE EXCLUDED FROM COVERAGE UNDER THIS WARRANTY. SOME STATES/COUNTRIES DO NOT ALLOW FOR THE DISCLAIMERS, LIMITATIONS AND EXCLUSIONS IDENTIFIED ABOVE, AS A RESULT, THEY MAY NOT APPLY TO YOU. THIS WARRANTY GIVES YOU SPECIFIC LEGAL RIGHTS, AND YOU MAY ALSO HAVE OTHER LEGAL RIGHTS WHICH VARY FROM STATE TO STATE AND COUNTRY TO COUNTRY.

### 3 Year Limited Warranty Against Corrosion (Worldwide)

**WHAT IS COVERED:** Mercury Marine warrants that each new Mercury, Mariner, Mercury Racing, Sport Jet, M<sup>2</sup> Jet Drive, Tracker by Mercury Marine Outboard, MerCruiser Inboard or sterndrive engine (Product) will not be rendered inoperative as a direct result of corrosion for the period of time described below.

**DURATION OF COVERAGE:** This limited corrosion warranty provides coverage for three (3) years from either the date the product is first sold, or the date on which the product is first put into service, whichever occurs first. The repair or replacement of parts, or the performance of service under this warranty does not extend the life of this warranty beyond its original expiration date. Unexpired warranty coverage can be transferred to subsequent (non-commercial use) purchaser upon proper re-registration of the product.

**CONDITIONS THAT MUST BE MET IN ORDER TO OBTAIN WARRANTY COVERAGE:** Warranty coverage is available only to retail customers that purchase from a Dealer authorized by Mercury Marine to distribute the product in the country in which the sale occurred, and then only after the Mercury Marine specified pre-delivery inspection process is completed and documented. Warranty coverage becomes available upon proper registration of the product by the authorized dealer. Corrosion prevention devices specified in the Operation and Maintenance Manual must be in use on the boat, and routine maintenance outlined in the Operation and Maintenance Manual must be timely performed (including without limitation the replacement of sacrificial anodes, use of specified lubricants, and touch-up of nicks and scratches) in order to maintain warranty coverage. Mercury Marine reserves the right to make warranty coverage contingent upon proof of proper maintenance.

**WHAT MERCURY WILL DO:** Mercury's sole and exclusive obligation under this warranty is limited to, at our option, repairing a corroded part, replacing such part or parts with new or Mercury Marine certified re-manufactured parts, or refunding the purchase price of the Mercury product. Mercury reserves the right to improve or modify products from time to time without assuming an obligation to modify products previously manufactured.

**HOW TO OBTAIN WARRANTY COVERAGE:** The customer must provide Mercury with a reasonable opportunity to repair, and reasonable access to the product for warranty service. Warranty claims shall be made by delivering the product for inspection to a Mercury dealer authorized to service the product. If purchaser cannot deliver the product to such a dealer, written notice must be given to Mercury. We will then arrange for the inspection and any covered repair. Purchaser in that case shall pay for all related transportation charges and/or travel time. If the service provided is not covered by this warranty, purchaser shall pay for all related labor and material, and any other expenses associated with that service. Purchaser shall not, unless requested by Mercury, ship the product or parts of the product directly to Mercury. Proof of registered ownership must be presented to the dealer at the time warranty service is requested in order to obtain coverage.

**WHAT IS NOT COVERED:** This limited warranty does not cover electrical system corrosion; corrosion resulting from damage, corrosion which causes purely cosmetic damage, abuse or improper service; corrosion to accessories, instruments, steering systems; corrosion to factory installed jet drive unit; damage due to marine growth; product sold with less than a one year limited Product warranty; replacement parts (parts purchased by customer); products used in a commercial application. Commercial use is defined as any work or employment related use of the product, or any use of the product which generates income, for any part of the warranty period, even if the product is only occasionally used for such purposes.

## Warranty Coverage And Exclusions

The purpose of this section is to help eliminate some of the more common misunderstandings regarding warranty coverage. The following information explains some of the types of services that are not covered by warranty. The provisions set forth following have been incorporated by reference into the Three Year Limited Warranty Against Corrosion Failure, the International Limited Outboard Warranty, and the United States and Canada Limited Outboard Warranty.

Keep in mind that warranty covers repairs that are needed within the warranty period because of defects in material and workmanship. Installation errors, accidents, normal wear, and a variety of other causes that affect the product are not covered.

Warranty is limited to defects in material or workmanship, but only when the consumer sale is made in the country to which distribution is authorized by us.

Should you have any questions concerning warranty coverage, contact your authorized dealer. They will be pleased to answer any questions that you may have.

### General Exclusions From Warranty

1. Minor adjustments and tune-ups, including checking, cleaning or adjusting spark plugs, ignition components, carburetor settings, filters, belts, controls, and checking lubrication made in connection with normal services.
2. Factory installed jet drive units - Specific parts excluded from the warranty are: The jet drive impeller and jet drive liner damaged by impact or wear, and water damaged drive shaft bearings as a result of improper maintenance.
3. Damage caused by neglect, lack of maintenance, accident, abnormal operation or improper installation or service.
4. Haul out, launch, towing charges, removal and/or replacement of boat partitions or material because of boat design for necessary access to the product, all related transportation charges and/or travel time, etc. Reasonable access must be provided to the product for warranty service. Customer must deliver product to an authorized dealer.
5. Additional service work requested by customer other than that necessary to satisfy the warranty obligation.
6. Labor performed by other than an authorized dealer may be covered only under following circumstances: When performed on emergency basis (providing there are no authorized dealers in the area who can perform the work required or have no facilities to haul out, etc., and prior factory approval has been given to have the work performed at this facility).
7. All incidental and/or consequential damages (storage charges, telephone or rental charges of any type, inconvenience or loss of time or income) are the owner's responsibility.
8. Use of other than Mercury Precision or Quicksilver parts when making warranty repairs.
9. Oils, lubricants or fluids changed as a matter of normal maintenance is customer's responsibility unless loss or contamination of same is caused by product failure that would be eligible for warranty consideration.
10. Participating in or preparing for racing or other competitive activity or operating with a racing type lower unit.
11. Engine noise does not necessarily indicate a serious engine problem. If diagnosis indicates a serious internal engine condition which could result in a failure, condition responsible for noise should be corrected under the warranty.
12. Lower unit and/or propeller damage caused by striking a submerged object is considered a marine hazard.
13. Water entering engine through the fuel intake, air intake or exhaust system or submersion.
14. Failure of any parts caused by lack of cooling water, which results from starting motor out of water, foreign material blocking inlet holes, motor being mounted too high or trimmed too far out.



15. Use of fuels and lubricants which are not suitable for use with or on the product. Refer to the **Maintenance** section.
16. Our limited warranty does not apply to any damage to our products caused by the installation or use of parts and accessories which are not manufactured or sold by us. Failures which are not related to the use of those parts or accessories are covered under warranty if they otherwise meet the terms of the limited warranty for that product.

Notes:

# Section 2 - Getting to Know Your Power Package

## Table of Contents

2

---

Lanyard Stop Switch.....	12	Console Mount Features- Dual Engine.....	20
Instrumentation.....	13	Synchronizing Dual Engines.....	20
System View .....	13	Dual Helm Station Transfer.....	21
Digital Gauges .....	14	Synchronizing Dual Helms Prior To Station	
Analog Gauges .....	14	Transfer .....	22
Remote Controls (Non-DTS Models).....	15	Zero Effort Features.....	22
Remote Controls.....	15	Electrical System Overload Protection.....	22
Panel Mount Features .....	15	Audio Warning System.....	24
Console Mount Features .....	16	Testing The Audio Warning System .....	24
Zero Effort Features.....	16	Engine Guardian Strategy.....	24
Remote Controls (DTS Models).....	17	Transmission Guardian Strategy.....	25
Remote Controls.....	17	Warning Horn Signals.....	25
Panel Mount Features.....	17	Emissions Information.....	25
Console Mount Features - Single Engine.....	18	Emission Control Information Label.....	25
Slim Binnacle Console Mount Features - Single		Owner Responsibility .....	26
Engine.....	19	Star Label.....	26

---

## Lanyard Stop Switch

The purpose of a lanyard stop switch is to turn off the engine when the operator moves outside the operator's position (as in accidental ejection from the operator's position).

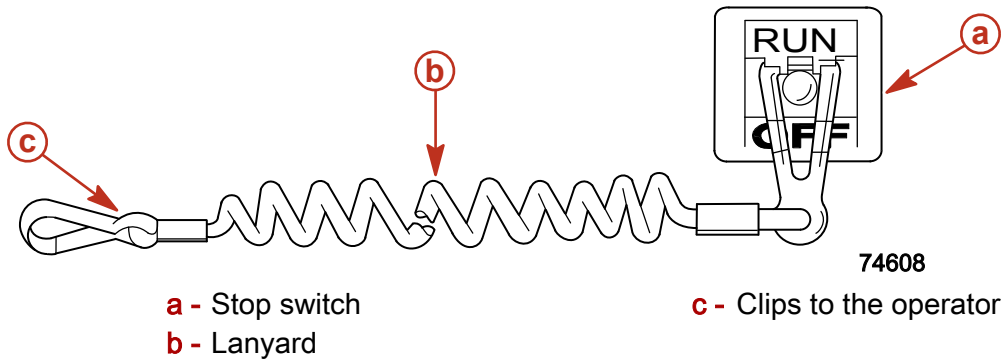

Accidental ejections, such as falling overboard, are more likely to occur in:

- low sided sport boats
- bass boats
- high performance boats

Accidental ejections can also occur from:

- poor operating practices
- sitting on the seat or gunwale at planing speeds
- standing at planing speeds
- operating at planing speeds in shallow or obstacle infested waters
- releasing your grip on the steering wheel that is pulling in one direction
- consuming alcohol or drugs
- high speed boating maneuvers

The lanyard is a cord usually between 122 and 152 cm (4 and 5 feet) in length when stretched out, with an element on one end made to be inserted into the switch and a snap on the other end for attaching to the operator. The lanyard is coiled to make its at-rest condition as short as possible to minimize the likelihood of lanyard entanglement with nearby objects. Its stretched-out length is made to minimize the likelihood of accidental activation should the operator choose to move around in an area close to the normal operator's position. If it is desired to have a shorter lanyard, wrap the lanyard around the operator's wrist or leg, or tie a knot in the lanyard.

Activation of the lanyard stop switch will stop the engine immediately, but the boat will continue to coast for some distance depending upon the velocity and degree of any turn at shut down. However, the boat will not complete a full circle. While the boat is coasting, it can cause injury to anyone in the boat's path as seriously as the boat would when under power.

We strongly recommend that other occupants be instructed on proper starting and operating procedures should they be required to operate the engine in an emergency (e.g. if the operator is accidentally ejected).

### **⚠ WARNING**

**Avoid contact with the boat hull and propeller from accidental ejection. Personal injury or death could occur. Always properly connect both ends of the lanyard stop switch.**

Accidental or unintended activation of the switch during normal operation is also a possibility. This could cause any, or all, of the following potentially hazardous situations:

- Occupants could be thrown forward due to unexpected loss of forward motion, a particular concern for passengers in the front of the boat who could be ejected over the bow and possibly struck by the propulsion or steering components.
- Loss of power and directional control in heavy seas, strong current or high winds.
- Loss of control when docking.

### ⚠ WARNING

Avoid abrupt deceleration of the boat from lanyard stop switch activation. Boat damage and personal injury or death could occur. Never leave the operator's station with the engine operating and in gear.

## Instrumentation

### System View

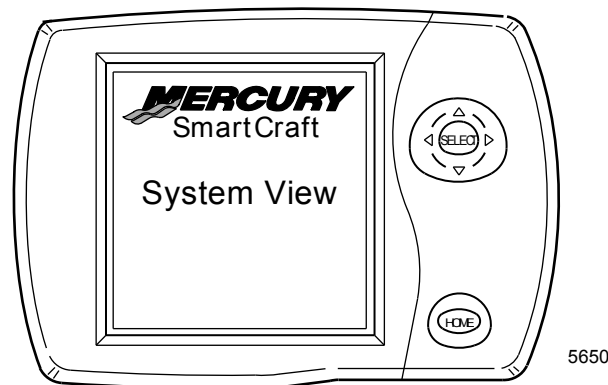

Your power package may be connected to the Mercury SC5000 SmartCraft System View display. The display monitors and reports information ranging from basic operating data to engine alarm data.

The SC5000 System View Display is a comprehensive boat information center. System View allows the boat operator to receive a wealth of critical operational information, displayed clearly and instantly at the helm on the LCD display. The System View continuously monitors and reports information ranging from basic operating data to detailed vessel environment information. System View displays water temperature and depth, engine trim status, boat speed, steering angle, system preventive maintenance reminders and systems diagnostics. System View also can be fully integrated with the boat's GPS, if equipped, to provide up to the minute location, course, speed, and fuel-to-destination information.

When a problem is detected with the engine or system, the System View will alert the operator to the potential problem by displaying the alarm message in the information window, located at the bottom of the view screen.

If the problem can cause immediate engine damage, the Engine Guardian System will respond to the problem by limiting engine power. Immediately reduce throttle speed to idle. Refer to the System View Operation Manual for further explanation of the problem and the correct action to take.

## Digital Gauges

A Mercury SmartCraft System instrument package can be purchased for this product. A few of the functions the instrument package will display are engine RPM, coolant temperature, oil pressure, battery voltage, fuel consumption and engine operating hours.

The SmartCraft Instrument package will also aid in Engine Guardian diagnostics. The SmartCraft Instrument package will display critical engine alarm data and potential problems.

Refer to the manual with your gauge package for the warning functions monitored and basic operation of the SmartCraft Instrument package.

## Analog Gauges

The following is a brief explanation of the instrumentation typically found on some boats. The owner/operator should be familiar with all instruments and their functions. Because of the large variety of instrumentation and manufacturers, you should have your boat dealer explain the particular gauges and normal readings for your boat.

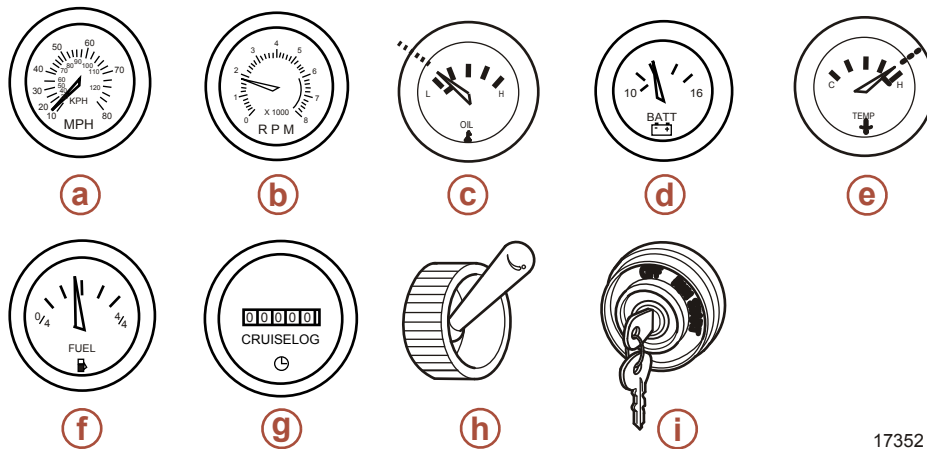

17352

- a - Speedometer
- b - Tachometer
- c - Oil pressure gauge
- d - Voltmeter
- e - Water temperature gauge
- f - Fuel gauge
- g - Hour meter
- h - Bilge blower switch
- i - Ignition switch

**Speedometer:** Indicates boat speed.

**Tachometer:** Indicates engine RPM.

**Oil Pressure Gauge:** Indicates engine oil pressure.

**Voltmeter:** Indicates battery voltage.

**Water Temperature Gauge:** Indicates engine operating temperature.

**Fuel Gauge:** Indicates quantity of fuel in tank.

**Hour meter:** Records engine operating time.

**Bilge Blower Switch:** Operates bilge blower.

**Ignition Switch:** Allows operator to start and stop engine.

## Remote Controls (Non-DTS Models)

### Remote Controls

Your boat may be equipped with a Mercury Precision Parts or Quicksilver remote controls. All controls may not have all features shown. Consult your dealer for a description and/or demonstration of your remote control.

#### PANEL MOUNT FEATURES

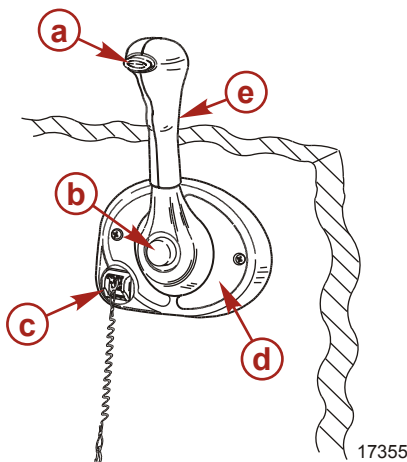

- |                                 |  |
|---------------------------------|--|
| <b>a</b> - Neutral lock button  | <b>d</b> - Control handle tension adjustment screw |
| <b>b</b> - Throttle only button | <b>e</b> - Control handle                          |
| <b>c</b> - Lanyard stop switch  |  |

**Neutral Lock Button** - Prevents accidental shift and throttle engagement. Neutral lock button must be pushed in to move the control handle out of neutral.

**Throttle Only Button** - Allows engine throttle advancement without shifting the engine. This is done by disengaging the shift mechanism from the control handle. The throttle only button can be depressed only when the remote control handle is in the neutral position, and should only be used to assist in starting the engine.

**Lanyard Stop Switch** - Turns the ignition off whenever the operator (when attached to the lanyard) moves far enough away from the operator's position to activate the switch. Refer to **Lanyard Stop Switch** for information on the use of this switch.

**Control Handle** - Operation of the shift and throttle are controlled by the movement of the control handle. Push the control handle forward from neutral with a quick firm motion to the first detent for forward gear. Continue pushing forward to increase speed. Pull the control handle back from neutral with a quick firm motion to the first detent for reverse gear and continue pushing back to increase speed.

**Control Handle Tension Adjustment Screw - (not visible)** This screw is used to adjust the effort required to move the remote control handle. Refer to instructions provided with remote control for complete adjustment instructions.

## CONSOLE MOUNT FEATURES

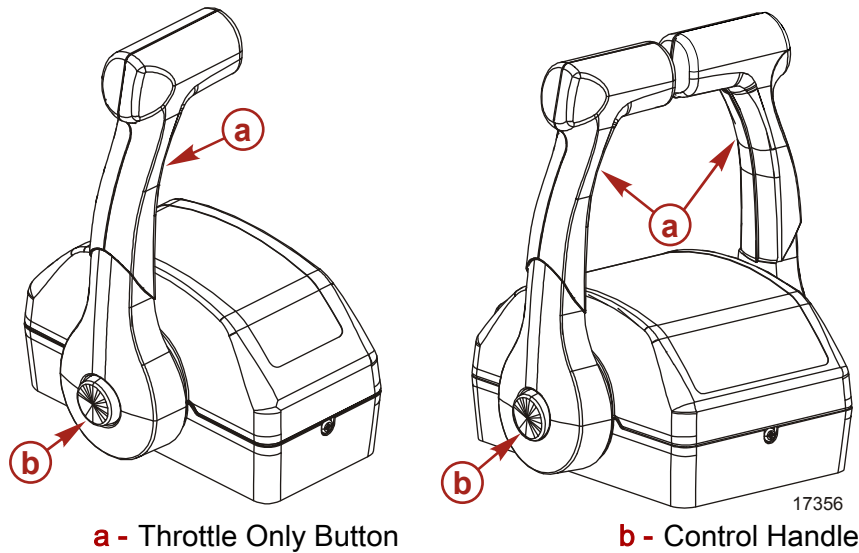

**Throttle Only Button** - Allows engine throttle advancement without shifting the engine. This is done by disengaging the shift mechanism from the control handle. The throttle only button can be depressed only when the remote control handle is in the neutral position.

**Control Handles** - Operation of the the shift and throttle are controlled by the movement of the control handle. Push the control handle forward from neutral with a quick firm motion to the first detent for forward gear and continue pushing forward to increase speed. Pull the control handle back from neutral with a quick firm motion to the first detent for reverse gear and continue pushing back to increase speed.

**Control Handle Tension Adjustment Screw - (not visible)** This screw is used to adjust the effort required to move the remote control handle. Refer to instructions provided with remote control for complete adjustment instructions.

## Zero Effort Features

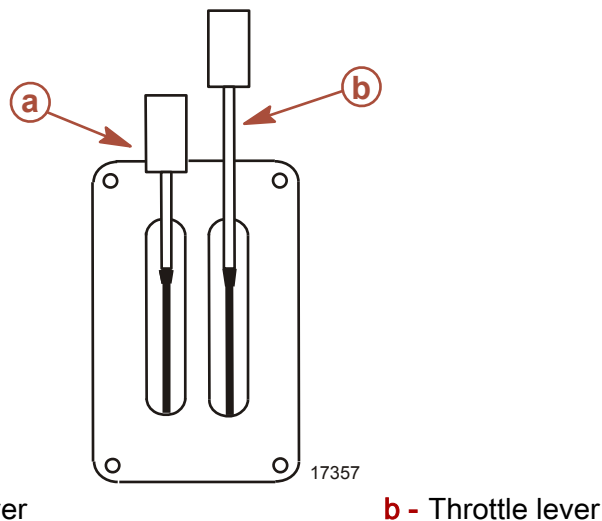

**Shift Lever** - Shift functions are controlled by the movement of the shift lever. Shift into reverse by moving the shift lever to its aft position. Shift into neutral by moving the shift lever to its center position. Shift into forward by moving the shift lever to its forward position.



**Throttle Lever** - Throttle functions are controlled by the movement of the throttle lever. Increase the RPM by moving the throttle lever forward. Achieve Wide Open Throttle (WOT) by placing the throttle lever in its full forward position. Decrease RPM by moving the throttle lever back. Achieve minimum RPM (idle) by placing the throttle lever in its full aft position.

## Remote Controls (DTS Models)

### Remote Controls

**IMPORTANT:** Your boat must be equipped with a Mercury Marine electronic remote control. Start in gear protection is provided by this control system and prevents the engine from starting when the control is actuated in forward or reverse. Refer to the Mercury Precision Parts/Quicksilver Accessories Guide.

The Digital Throttle and Shift System (DTS) required to operate this engine package provides start and stop functions, throttle control, shift control, start in gear protection, and emergency lanyard stop functions. The DTS system works with specialized helm components such as a command module kit and electronic remote control. Consult your dealer for a description and/or demonstration of your remote control.

### Panel Mount Features

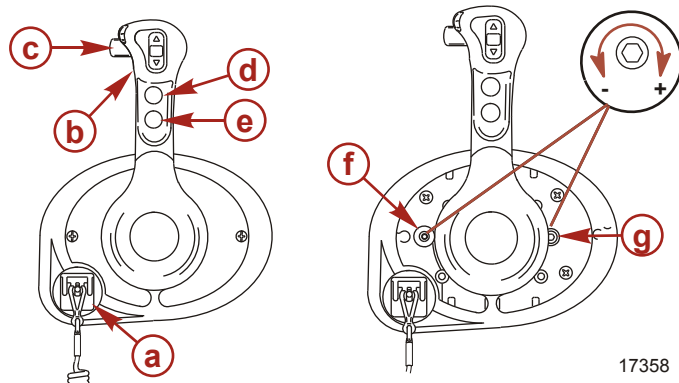

- a** - Lanyard stop switch
- b** - Control handle
- c** - Shift lock
- d** - Trim/tilt switch
- e** - Throttle only button
- f** - Start/stop button
- g** - Detent tension adjustment screw
- h** - Control handle friction adjustment screw

**Lanyard Stop Switch** - Turns the ignition off whenever the operator (when attached to the lanyard) moves far enough away from the operator's position to activate the switch. Refer to **Lanyard Stop Switch** for information on the use of this switch.

**Control Handle** - Operation of the shift and throttle are controlled by the movement of the control handle. Push the control handle forward from neutral with a quick, firm motion to the first detent for forward gear. Continue pushing forward to increase speed. Pull the control handle back from neutral with a quick, firm motion to the first detent for reverse gear and continue pushing back to increase speed.

**Shift Lock** - Pressing the shift lock allows the engine to shift. The shift lock must always be pressed when moving the control handle out of the neutral position.

**Throttle Only Button** - Allows engine throttle advancement without shifting the engine. The throttle only button can be depressed only when the remote control is in the neutral position, and should only be used to assist in starting or warming up the engine.

**Start/Stop Button** - Allows the boat operator to start or stop the engine without using the ignition key.

**Detent Tension Adjustment Screw** - This screw can be adjusted to increase or decrease the effort required to move the control handle out of the detent positions (cover must be removed). Turning the screw clockwise will increase tension.

**Control Handle Friction Adjustment Screw** - This screw can be adjusted to increase or decrease the tension on the control handle (cover must be removed). This will help prevent unwanted motion of the handle in rough water. Turn the screw clockwise to increase tension and counterclockwise to decrease tension.

## Console Mount Features - Single Engine

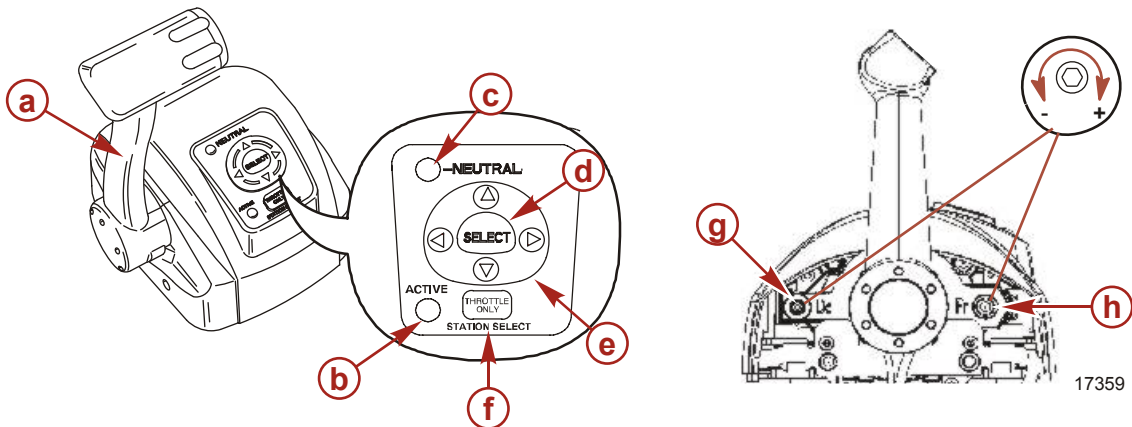

- a - Control handle
- b - Active light
- c - Neutral light
- d - Select key
- e - Arrow trackpad
- f - Throttle only/station select key
- g - Detent tension adjustment
- h - Control handle friction adjustment screw

**Control Handle** - Operation of the shift and throttle are controlled by the movement of the control handle. Push the control handle forward from neutral with a quick, firm motion to the first detent for forward gear. Continue pushing forward to increase speed. Pull the control handle back from neutral with a quick, firm motion to the first detent for reverse gear and continue pushing back to increase speed.

**Active Light** - The active light is illuminated to show the remote control is active and ready for use.

**Neutral Light** - The neutral light is illuminated when the engine is in neutral gear position.

**Select Key** - Selects System View on-screen options and confirms data entries.

**Arrow Trackpad** - Navigates through System View on-screen function messages.

**Throttle Only/Station Select Key** - Allows engine throttle advancement without shifting the engine. The throttle only/station select button also allows the boat operator to select which remote control is in control of the engine operation when operating with multiple helms. Refer to **Dual Helm Station Transfer**.

**Detent Tension Adjustment Screw** - This screw can be adjusted to increase or decrease the effort required to move the control handle out of the detent positions (cover must be removed). Turning the screw clockwise will increase tension.

**Control Handle Friction Adjustment Screw** - This screw can be adjusted to increase or decrease the tension on the control handle (cover must be removed). This will help prevent unwanted motion of the handle in rough water. Turn the screw clockwise to increase tension and counterclockwise to decrease tension.

## Slim Binnacle Console Mount Features - Single Engine

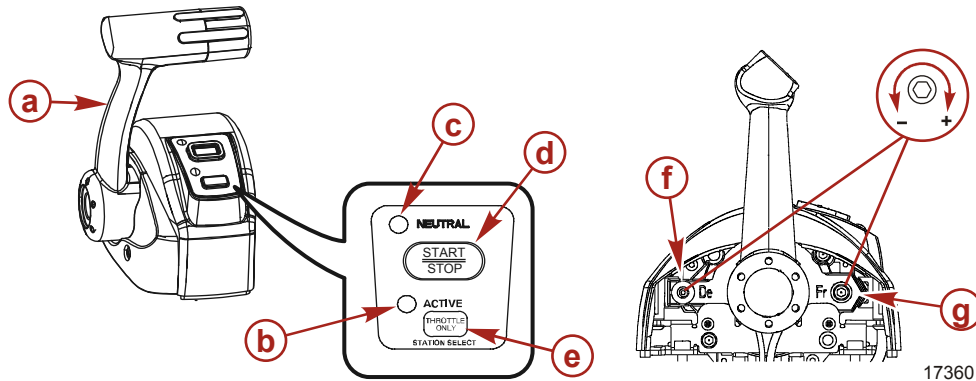

- a - Control handle
- b - Active light
- c - Neutral light
- d - Start/stop button
- e - Throttle only/station select key
- f - Detent tension adjustment
- g - Control handle friction adjustment screw

**Control Handle** - Operation of the shift and throttle are controlled by the movement of the control handle. Push the control handle forward from neutral with a quick, firm motion to the first detent for forward gear. Continue pushing forward to increase speed. Pull the control handle back from neutral with a quick, firm motion to the first detent for reverse gear and continue pushing back to increase speed.

**Active Light** - The active light is illuminated to show the remote control is active and ready for use.

**Neutral Light** - The neutral light is illuminated when the engine is in neutral gear position.

**Start/Stop Button** - Allows the boat operator to start or stop the engine without using the ignition key.

**Throttle Only/Station Select Key** - Allows engine throttle advancement without shifting the engine. The throttle only/station select button also allows the boat operator to select which remote control is in control of the engine operation when operating with multiple helms. Refer to **Dual Helm Station Transfer**.

**Detent Tension Adjustment Screw** - This screw can be adjusted to increase or decrease the effort required to move the control handle out of the detent positions (cover must be removed). Turning the screw clockwise will increase tension.

**Control Handle Friction Adjustment Screw** - This screw can be adjusted to increase or decrease the tension on the control handle (cover must be removed). This will help prevent unwanted motion of the handle in rough water. Turn the screw clockwise to increase tension and counterclockwise to decrease tension.

## Console Mount Features- Dual Engine

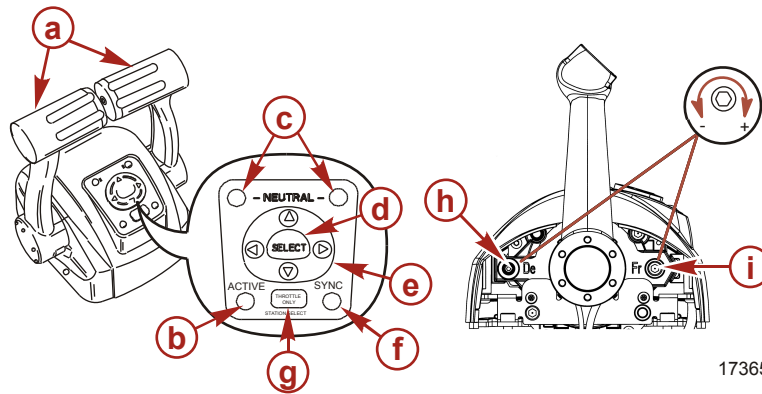

- a - Control handles
- b - Active light
- c - Neutral light
- d - Select key
- e - Arrow trackpad

- f - Sync light
- g - Throttle only/station select key
- h - Detent tension adjustment
- i - Control handle friction adjustment screw

**Control Handle** - Operation of the shift and throttle are controlled by the movement of the control handle. Push the control handle forward from neutral with a quick, firm motion to the first detent for forward gear. Continue pushing forward to increase speed. Pull the control handle back from neutral with a quick, firm motion to the first detent for reverse gear and continue pushing back to increase speed.

**Active Light** - The active light is illuminated to show the remote control is active and ready for use.

**Neutral Light** - The neutral light is illuminated when the engine is in neutral gear position.

**Select Key** - Selects System View on-screen options and confirms data entries.

**Arrow Trackpad** - Navigates through System View on-screen function messages.

**Sync Light** - The sync light is illuminated when the RPM of the two engines are being synchronized by the DTS system.

**Throttle Only/Station Select Key** - Allows engine throttle advancement without shifting the engine. The throttle only/station select button also allows the boat operator to select which remote control is in control of the engine operation when operating with multiple helms. Refer to **Dual Helm Station Transfer**.

**Detent Tension Adjustment Screw** - This screw can be adjusted to increase or decrease the effort required to move the control handle out of the detent positions (cover must be removed). Turning the screw clockwise will increase tension.

**Control Handle Friction Adjustment Screw** - This screw can be adjusted to increase or decrease the tension on the control handle (cover must be removed). This will help prevent unwanted motion of the handle in rough water. Turn the screw clockwise to increase tension and counterclockwise to decrease tension.

## Synchronizing Dual Engines

The auto synchronizing feature, when engaged, will automatically adjust the port engine speed to match the speed of the starboard engine.

Synchronizing of engines will automatically engage when the speed of both engines are over 900 RPM for two seconds and remote control handles are positioned within 5° of each other.

Auto Synchronizing will stay engaged up to 95% throttle opening. The Sync light will turn on when the engines are synchronized.

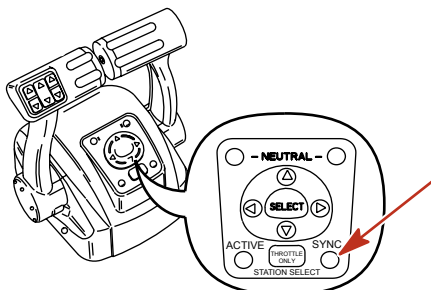

3434

To disengage, move one or both control handles until they are more than 5° apart, reduce engine speed below 900 RPM, or increase engine speed beyond 95%.

## Dual Helm Station Transfer

The throttle only/station select button allows the boat operator to select which remote control is in control of the engine operation.

The active light is illuminated at the remote control station that is in control of the engine.

### ⚠ WARNING

Avoid serious injury or death from loss of boat control. The boat operator should never leave the active station while engine is in gear. Helm transfer should only be attempted while both stations are manned. One person helm transfer should only be performed while engine is in neutral.

**NOTE:** Idle position is preferred when doing a station transfer. If conditions do not allow the remote control to be placed at idle position, a station transfer can be done while in gear.

**NOTE:** Pressing and releasing station select button at new station allows the engine control to be transferred to the new station. The control will automatically start adjusting engine RPM and gear position to match the control handle setting at the new station. Adjust control handles to the desired throttle and gear position.

1. Place active remote control lever to idle position.
2. Proceed to the inactive helm station and position remote control lever to the idle position.
3. Press throttle only/station select button once. The "ACTIVE" light will illuminate to indicate the remote control station is in control of the engine.

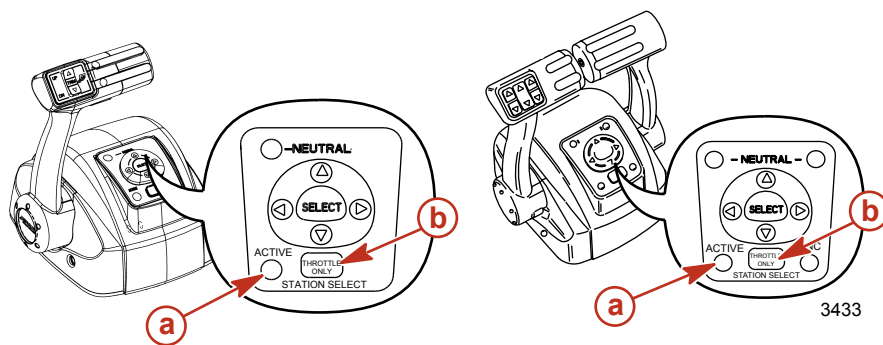

**a** - Active light

**b** - Throttle only/station select button

4. The active light will switch off at the original remote control station.

## SYNCHRONIZING DUAL HELMS PRIOR TO STATION TRANSFER

Pressing the station select button and holding it in allows the boat operator 10 seconds to match up the control handle settings at the new station with the handle settings that are at the old (to be inactive) station. If the handles are not matched, the neutral light will flash. The light blinks faster as the handles are nearing match position. Once the light stays on continuously, the handles are matched and the button can be released. Transfer process is complete and the new station is now in control. If the button is held for over 10 seconds, the station transfer is cancelled.

## Zero Effort Features

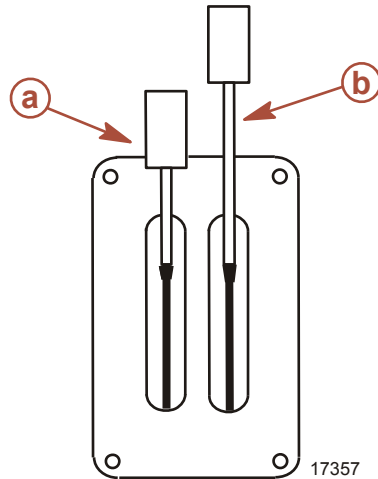

a - Shift lever

b - Throttle lever

**Shift Lever** - Shift functions are controlled by the movement of the shift lever. Shift into reverse by moving the shift lever to its aft position. Shift into neutral by moving the shift lever to its center position. Shift into forward by moving the shift lever to its forward position.

**Throttle Lever** - Throttle functions are controlled by the movement of the throttle lever. Increase the RPM by moving the throttle lever forward. Achieve Wide Open Throttle (WOT) by placing the throttle lever in its full forward position. Decrease RPM by moving the throttle lever back. Achieve minimum RPM (idle) by placing the throttle lever in its full aft position.

## Electrical System Overload Protection

If an electrical overload occurs, a fuse will blow or the circuit breaker will trip open. The cause must be found and corrected before replacing the fuse or resetting the circuit breaker.

**NOTE:** *In an emergency, when the engine must be operated and the cause for the high current draw cannot be located and corrected, turn off or disconnect all accessories connected to the engine and instrumentation wiring. Reset the circuit breaker. If the breaker remains open, the electrical overload has not been eliminated. Further checks must be made on the electrical system. Contact your authorized dealer.*

1. A circuit breaker provides protection for engine wiring harness and the instrumentation power lead. Reset by pushing the red "RESET" button in, or by pushing down the yellow lever.

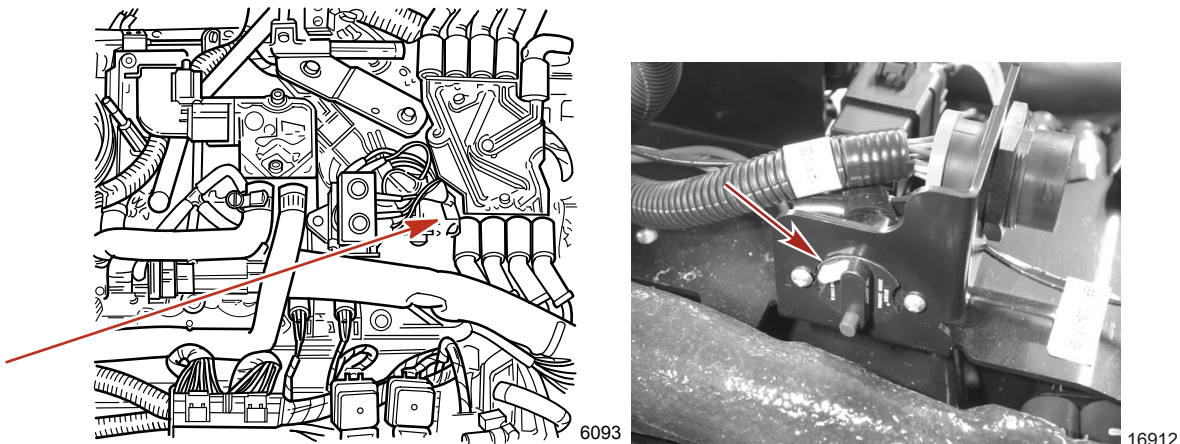

2. A 90 amp fuse is located on the large post of the starter solenoid. This fuse is designed to protect the engine wiring harness if an electrical overload occurs.

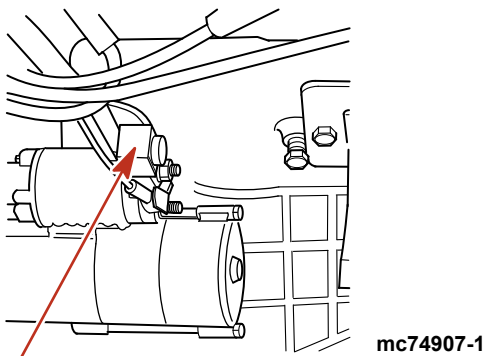

3. Four fuses are located on the port side of the engine. These fuses protect the main power, fuel pump, ignition, and SmartCraft circuits.

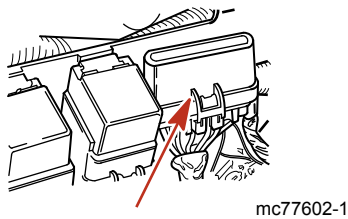

4. A 20 amp fuse may be located in the ignition switch "I" terminal lead to protect the electrical system. Check for blown fuse if the ignition key is turned to the "START" position and nothing happens (and circuit breaker is not tripped).

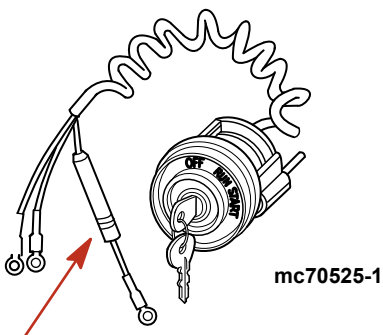

## Audio Warning System

Your Mercury MerCruiser power package may be equipped with an Audio Warning System. The Audio Warning System will not protect the engine from damage. It is designed to warn the operator that a problem has occurred.

The audio warning system will sound with a continuous horn if one of the following occurs:

- Engine oil pressure too low
- Engine temperature too hot
- Seawater pressure too low

The audio warning system will sound with an intermittent beeping if the following occurs:

- Transmission fluid temperature too hot
- Transmission pressure too low

### CAUTION

**Operation of the engine after the audio warning system alarm has sounded could result in damage to the power package. Do not operate engine once the alarm has sounded except to avoid a hazardous situation.**

If the alarm sounds, stop the engine immediately. Investigate cause and correct it, if possible. If the cause cannot be determined, contact your authorized Mercury MerCruiser dealer.

## Testing The Audio Warning System

1. Turn the ignition switch to the "ON" position without cranking the engine.
2. Listen for the audio alarm. The alarm will sound if the system is functioning correctly.

## Engine Guardian Strategy

**IMPORTANT: Boat speed could be reduced to idle and may not respond to the throttle.**

Engine Guardian Strategy is designed to help reduce the potential for engine damage by reducing engine power when a potential problem is sensed by the ECM. Engine Guardian monitors:

- Oil pressure
- Coolant temperature
- Seawater pressure
- Engine overspeed
- Exhaust Manifold Temperature [8.1 liter (496 cid) engines only]

Also the Engine Guardian Strategy will reduce engine power to 90 percent of maximum if any sensor on the power package fails.

For example, if the water inlet becomes partially blocked, Engine Guardian Strategy will reduce the available power level of the engine to help prevent damage from decreased water flow to the engine. If the debris passes through and full water flow is restored, engine power levels are restored to normal.

To avoid a possible recurrence of the problem you should contact an authorized dealer. The ECM stores the fault and with this information the technician will be able to more rapidly diagnose problems.



## Transmission Guardian Strategy

**IMPORTANT: Boat speed could be reduced to idle and may not respond to the throttle.**

Transmission Guardian is a MerCruiser DTS feature that protects transmissions from clutch damage. Transmission Guardian monitors the clutch pack pressure in forward and reverse gears. If the transmission fluid pressure drops below a predetermined level, Transmission Guardian lowers the engine torque and speed to prevent clutch slippage.

To avoid possible recurrence of the problem, you should contact an authorized dealer. The ECM stores the fault and with this information the technician will be able to more rapidly diagnose problems.

## Warning Horn Signals

Most faults will cause the warning horn circuit to activate. How the warning horn activates depends on how serious the problem is. There are four warning horn states:

- Caution - horn signal varies with product line and calibration. Minimal guardian.
- Warning - horn signal varies with product line and calibration.
- Severe - horn is beeping constantly.
- Critical - horn is beeping constantly and guardian will be at forced idle.

In addition, depending on the gauge package, there will be warning icons and fault messages on the dash mounted gauges.

## Emissions Information

### Emission Control Information Label

A tamper-resistant Emission Control Information label is affixed in a visible location to the engine at time of manufacture by Mercury MerCruiser. In addition to the required emissions statement, the label lists the engine serial number, family, FEL (emission level), date of manufacture (month, year), and the engine displacement. Please note that the low emissions certification will not affect the fit, function, or performance of the engines. Boatbuilders and dealers may not remove the label or the part it is affixed to before sale. If modifications are necessary, contact Mercury MerCruiser about the availability of replacement decals before proceeding.

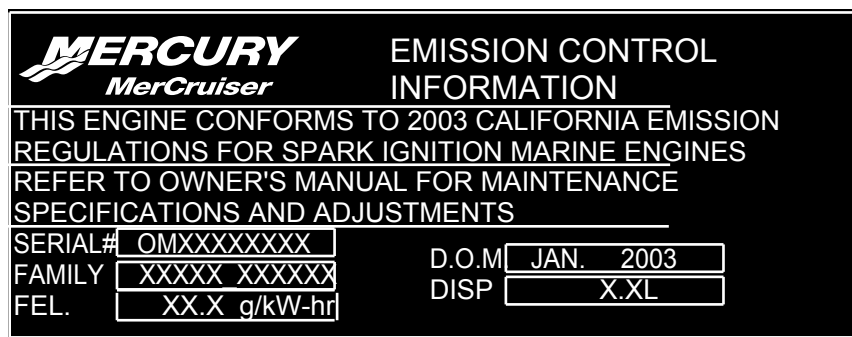

11018

#### Emission Control Label - Non CE Marked

"SERIAL#" - Engine Serial Number

"FAMILY" - Engine Family

"FEL." - Family Emission Limit

"D.O.M." - Date of Manufacture

"DISP" - Piston Displacement

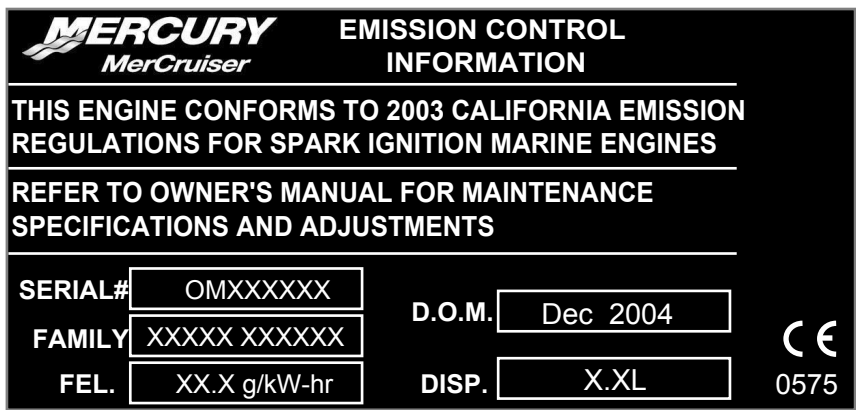

10652

**Emission Control Label - CE Marked**

"SERIAL#" - Engine Serial Number

"FAMILY" - Engine Family

"FEL." - Family Emission Limit

"D.O.M." - Date of Manufacture

"DISP" - Piston Displacement

CE - When this mark is present in the lower right corner of the Emission Control Information Label, on the engine, the Declaration of Conformance applies. Refer to the front page of this Manual for further information.

**OWNER RESPONSIBILITY**

The owner/operator is required to have routine engine maintenance performed to maintain emission levels within prescribed certification standards.

The owner/operator is not to modify the engine in any manner that would alter the horsepower or allow emissions levels to exceed their predetermined factory specifications.

**Star Label**

Beginning January 1, 2003, one Three-Star label will be included with each factory-certified Mercury MerCruiser engine.



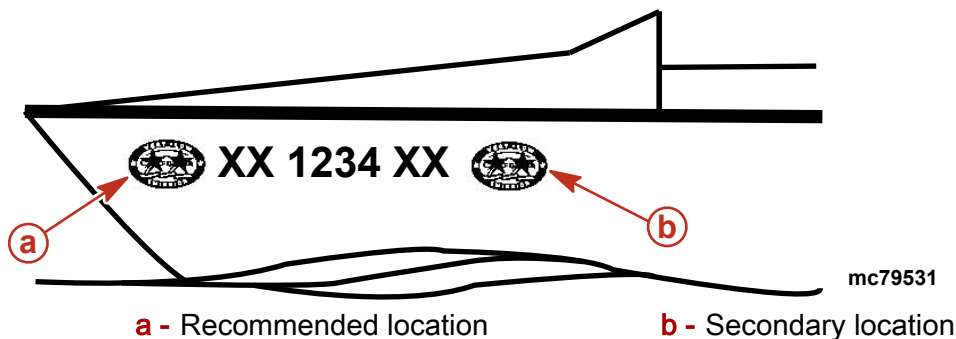

All Mercury MerCruiser engines (500 hp and below) will have a Three-Star Ultra Low Emission rating. The Three-Star label identifies that these engines meet the California Air Resources Board's Sterndrive and Inboard marine engine 2003 exhaust emission standards. Engines meeting these standards have 65% lower emissions than One-Star - Low Emissions engines.

The Three-Star label will be affixed on the left side of the hull as shown.



**a** - Recommended location

**b** - Secondary location

<b>One Star - Low emission</b>	
 <p>The logo features a single star with a banner below it. The text 'LOW' is at the top, 'CALIFORNIA EMISSIONS STANDARDS' is in a curve above the star, and 'EMISSION' is at the bottom. The code 'mc79569-1' is to the right.</p>	<p>The one-star label identifies personal watercraft, outboard, sterndrive and inboard engines that meet the Air Resources Board's Personal Watercraft and Outboard marine engine 2001 exhaust emission standards. Engines meeting these standards have 75% lower emissions than conventional carbureted two-stroke engines. These engines are equivalent to the U.S. EPA's 2006 standards for marine engines.</p>
<b>Two Stars - Very Low emission</b>	
 <p>The logo features two stars with a banner below them. The text 'VERY LOW' is at the top, 'CALIFORNIA EMISSIONS STANDARDS' is in a curve above the stars, and 'EMISSION' is at the bottom. The code 'mc79570-1' is to the right.</p>	<p>The two-star label identifies personal watercraft, outboard, sterndrive and inboard engines that meet the Air Resources Board's Personal Watercraft and Outboard marine engine 2004 exhaust emission standards. Engines meeting these standards have 20% lower emissions than One Star - Low-Emission engines.</p>
<b>Three Stars - Ultra Low emission</b>	
 <p>The logo features three stars with a banner below them. The text 'ULTRA LOW' is at the top, 'CALIFORNIA EMISSIONS STANDARDS' is in a curve above the stars, and 'EMISSION' is at the bottom. The code 'mc79571-1' is to the right.</p>	<p>The three-star label identifies engines that meet the Air Resources Board's Personal Watercraft and Outboard marine engine 2008 exhaust emission standards or the Sterndrive and Inboard marine engine 2003 exhaust emission standards. Engines meeting these standards have 65% lower emissions than One Star - Low Emission engines.</p>
<b>Four Stars - Super Ultra Low emission</b>	
 <p>The logo features four stars with a banner below them. The text 'SUPER ULTRA LOW' is at the top, 'CALIFORNIA EMISSIONS STANDARDS' is in a curve above the stars, and 'EMISSION' is at the bottom. The code 'mc79572-1' is to the right.</p>	<p>The Four Star label identifies engines that meet the Air Resources Board's Sterndrive and Inboard marine engine 2009 exhaust emission standards. Personal Watercraft and Outboard marine engines may also comply with these standards. Engines meeting these standards have 90% lower emissions than One Star - Low Emission engines.</p>

## Notes:

## Section 3 - On The Water

### Table of Contents

Safe Boating Suggestions.....	30	While You Are Cruising .....	38
Be Alert To Carbon Monoxide Poisoning.....	31	While Boat Is Stationary .....	38
Good Ventilation .....	32	High-Speed And High-Performance Boat Operation .....	38
Poor Ventilation .....	32	Passenger Safety In Pontoon Boats And Deck Boats.....	38
Basic Boat Operation (Non-DTS Models).....	32	Boats Having An Open Front Deck .....	38
Launching and Boat Operation.....	32	Boats With Front-Mounted, Raised Pedestal Fishing Seats .....	39
Operation Chart .....	33	Wave And Wake Jumping.....	39
Starting and Stopping the Engine.....	33	Impact With Underwater Hazards.....	40
Starting the Engine .....	33	Conditions Affecting Operation.....	41
Stopping the Engine .....	34	Weight Distribution (Passengers and Gear) Inside the Boat.....	41
Throttle Only Operation.....	34	Bottom Of Boat.....	41
Freezing Temperature Operation.....	34	Cavitation.....	41
Drain Plug and Bilge Pump.....	34	Ventilation.....	41
Basic Boat Operation (DTS Models).....	35	Elevation And Climate.....	41
Launching and Boat Operation.....	35	Getting Started.....	42
Operation Chart .....	35	20-Hour Break-In Period.....	42
Starting and Stopping the Engine.....	35	After Break-In Period.....	42
Starting the Engine .....	35	End of First Season Checkup.....	42
Stopping the Engine .....	36		
Throttle Only Operation.....	37		
Freezing Temperature Operation.....	37		
Drain Plug and Bilge Pump.....	37		
Protecting People In The Water.....	38		

## Safe Boating Suggestions

In order to safely enjoy the waterways, familiarize yourself with local and all other governmental boating regulations and restrictions, and consider the following suggestions.

### **Know and obey all nautical rules and laws of the waterways.**

- Mercury MerCruiser strongly recommends that all powerboat operators complete a boating safety course. Courses are offered in the U.S.A. by: The U.S. Coast Guard Auxiliary, The Power Squadron, The Red Cross and your state or provincial boating law enforcement agency. Inquiries may be made to the Boating Hotline at 1-800-368-5647 or the Boat U.S. Foundation at 1-800-336-BOAT.

### **Perform safety checks and required maintenance.**

- Follow a regular schedule and ensure that all repairs are properly made.

### **Check safety equipment on board.**

- Here are some suggestions of the types of safety equipment to carry when boating:
  - Approved fire extinguishers
  - Signal devices: flashlight, rockets or flares, flag and whistle or horn
  - Tools necessary for minor repairs
  - Anchor and extra anchor line
  - Manual bilge pump and extra drain plugs
  - Drinking water
  - Transistor radio
  - Paddle or oar
  - Spare propeller, thrust hubs, and an appropriate wrench
  - First aid kit and instructions
  - Water-proof storage containers
  - Spare operating equipment, batteries, bulbs and fuses
  - Compass and map or chart of the area
  - Personal flotation device (1 per person on board)

### **Watch for signs of weather change and avoid foul weather and rough-sea boating.**

### **Tell someone where you are going and when you expect to return.**

### **Passenger boarding.**

- Stop the engine whenever passengers are boarding, unloading or are near the back (stern) of the boat. Shifting the drive unit into neutral is not sufficient.

### **Use personal flotation devices.**

- Federal Law requires that there be a U. S. Coast Guard approved life jacket (personal flotation device), correctly sized and readily accessible for every person on board, plus a throwable cushion or ring. We strongly advise that everyone wear a life jacket at all times while in the boat.

### **Prepare other boat operators.**

- Instruct at least 1 person on board in the basics of starting and operating the engine and boat handling in case the driver becomes disabled or falls overboard.

### **Do not overload your boat.**

- Most boats are rated and certified for maximum load (weight) capacities (refer to your boat capacity plate). Know your boat's operating and loading limitations. Know if your boat will float if full of water. When in doubt, contact your authorized Mercury MerCruiser dealer or the boat manufacturer.

**Ensure that everyone in the boat is properly seated.**

- Do not allow anyone to sit or ride on any part of the boat that was not intended for such use. This includes the backs of seats, gunwales, transom, bow, decks, raised fishing seats and any rotating fishing seat; anywhere that sudden unexpected acceleration, sudden stopping, unexpected loss of boat control or sudden boat movement could cause a person to be thrown overboard or into the boat. Ensure that all passengers have a proper seat and are in it before any boat movement.

**Never be under the influence of alcohol or drugs while boating (it is the law).**

- They impair your judgment and greatly reduce your ability to react quickly.

**Know your boating area and avoid hazardous locations.****Be alert.**

- The operator of the boat is responsible by law to maintain a proper lookout by sight and hearing. The operator must have an unobstructed view particularly to the front. No passengers, load or fishing seats should block the operators view when the boat is above idle or planing transition speed. Watch out for others, the water and your wake.

**Never drive your boat directly behind a water skier in case the skier falls.**

- As an example, your boat traveling at 40 km/h (25 MPH) will overtake a fallen skier who was 61 m (200 ft.) in front of you in 5 seconds.

**Watch fallen skiers.**

- When using your boat for water skiing or similar activities, always keep a fallen or down skier on the operator's side of the boat while returning to attend to the skier. The operator should always have the down skier in sight and never back up to the skier or anyone in the water.

**Report accidents.**

- Boat operators are required by law to file a Boating Accident Report with their state boating law enforcement agency when their boat is involved in certain boating accidents. A boating accident must be reported if 1) there is loss of life or probable loss of life, 2) there is personal injury requiring medical treatment beyond first aid, 3) there is damage to boats or other property where the damage value exceeds \$500.00 or 4) there is complete loss of the boat. Seek further assistance from local law enforcement.

## Be Alert To Carbon Monoxide Poisoning

Carbon monoxide is present in the exhaust fumes of all internal combustion engines including the outboards, sterndrives and inboard engines that propel boats, as well as the generators that power various boat accessories. Carbon monoxide is a deadly gas that is odorless, colorless and tasteless.

Early symptoms of carbon monoxide poisoning, which should not be confused with seasickness or intoxication, include headache, dizziness, drowsiness and nausea.

** WARNING**

**Avoid prolonged exposure to carbon monoxide. Carbon monoxide poisoning can lead to unconsciousness, brain damage or death. Ensure that the boat, while at rest or underway, is well ventilated.**

## Good Ventilation

Ventilate the passenger area, open the side curtains or forward hatches to remove fumes.

1. Example of desired air flow through the boat.



mc79553-1

## Poor Ventilation

Under certain conditions, permanently enclosed or canvas enclosed cabins or cockpits with insufficient ventilation may draw in carbon monoxide. Install one or more carbon monoxide detectors in your boat.

Although the occurrence is rare, on a very calm day, swimmers and passengers in an open area of a stationary boat that contains or is near an operating engine may be exposed to a hazardous level of carbon monoxide.

1. Examples of poor ventilation while a boat is stationary:

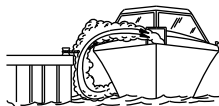

**a**

**a** - Operating the engine when the boat is moored in a confined space



**b**

**b** - Mooring close to another boat with its engine operating

mc79554-1

2. Examples of poor ventilation while a boat is moving:



**a**

**a** - Operating the boat with the trim angle of the bow too high



**b**

**b** - Operating the boat with no forward hatches open (station wagon effect)

mc79556-1

## Basic Boat Operation (Non-DTS Models)

### Launching and Boat Operation

**IMPORTANT:** Install bilge drain plug prior to launching boat.

#### **CAUTION**

To avoid possible ingestion of water that can damage engine components, do not turn the ignition key off when the engine is above idle speed. When launching your boat from a steep ramp, enter the water slowly. Do not use the lanyard stop switch to shut off the engine above idle speed. When coming off plane, if a large following wave may roll over the boat's transom, apply a short, light burst of throttle to minimize the wave action against the stern of the boat. Do not come off plane quickly, shift into reverse and shut off engine.



## OPERATION CHART

Operation Chart			
BEFORE STARTING	AFTER STARTING	WHILE UNDERWAY	AFTER STOPPING
Install bilge drain plug.	Observe all gauges to check condition of engine. If not normal, stop engine.	Observe all gauges to check condition of engine. If not normal, stop engine.	Turn ignition key to the "OFF" position.
Open engine hatch.	Check for fuel, oil, water, fluid and exhaust leaks.	Listen for the audio alarm.	Turn battery switch to the "OFF" position.
Turn battery switch on.	Check shift and throttle control operation.		Close fuel shut off valve.
Operate bilge blowers.	Check steering operation.		Close seacock, if equipped.
Open fuel shut off valve.			Flush cooling system if in saltwater.
Open seacock, if equipped.			Drain bilge.
Close the drain system.			
Check the engine oil.			
Perform all other checks specified by your dealer and/or boat builder.			
Listen for Audio Warning Alarm to sound when the ignition switch is in the "ON" position.			

## Starting and Stopping the Engine

*NOTE: Only perform those functions applicable to your power package.*

## STARTING THE ENGINE

1. Check all items listed in the Operation Chart.
2. Place the remote control handle in neutral.

**⚠ CAUTION**

Overheating from insufficient cooling water will cause engine and drive system damage. Ensure that there is sufficient water always available at water inlet holes during operation.

**⚠ WARNING**

Explosive gasoline fumes collect in the engine compartment. Avoid injury or property damage, operate the bilge blower for at least 5 minutes prior to starting the engine. If the boat is not equipped with a bilge blower, open the engine hatch and leave it open while starting the engine.

3. Turn ignition key to "START". Release key when engine starts and allow switch to return to "ON" position. Allow engine to warm up (6-10 minutes on first start of the day). The engine will normally idle at 900-1000 RPM and then return to normal idle RPM of approximately 750 RPM.

*NOTE: If the engine has not run for a long period of time it may require a couple of attempts while the fuel bowl refills.*

4. If engine does not start after 3 attempts:

- a. Push the **throttle only** button and position the remote control handle/throttle lever to the 1/4 throttle position.
  - b. Turn ignition key to "START". Release key when engine starts and allow switch to return to "ON" position.
5. If engine does not start after step 4:
- a. Move the remote control handle/throttle lever to full throttle position, then return to 1/4 throttle.
  - b. Turn ignition key to "START". Release key when engine starts and allow switch to return to "ON" position.
6. Inspect the power package for fuel, oil, water and exhaust leaks.
7. Move control handle with a firm, quick motion forward to shift to forward gear, or backward to shift to reverse. After shifting, advance throttle to desired setting.

 **CAUTION**

**Avoid damage to the drive system. Shifting the drive system at RPMs greater than engine idle speed may cause internal damage to the drive system. Shift the drive system only when the engine is at idle RPM.**

## STOPPING THE ENGINE

1. Move the remote control handle to neutral/idle and allow the engine to slow to idle speed. If engine has been operated at high speed for a long period of time, allow the engine to cool at idle speed for 3 to 5 minutes.
2. Turn ignition key to the "OFF" position.

## Throttle Only Operation

1. Refer to **Remote Controls** section for remote control features.
2. Move the control lever to the idle/neutral position.
3. Depress and hold the throttle only button, and move the control lever to the idle/forward or idle/reverse position.
4. Advancing the control lever beyond the idle/forward or idle/reverse position will cause engine speed to increase.

**IMPORTANT: Moving the control lever back to the idle/neutral position will disengage the throttle only button and allow the engine to shift into gear.**

5. Throttle only mode is deactivated by moving the control lever to the idle/neutral position. Moving the control lever from the idle/neutral position to the idle/forward or idle/reverse position without pressing the throttle only button will shift the unit into the chosen gear.

## Freezing Temperature Operation

**IMPORTANT: If the boat is operated during periods of freezing temperature, precautions must be taken to prevent freeze damage to the power package. Damage caused by freezing is not covered by Mercury MerCruiser Limited Warranty.**

## Drain Plug and Bilge Pump

The engine compartment in your boat is a natural place for water to collect. For this reason, boats are normally equipped with a drain plug and/or a bilge pump. It is very important to check these items on a regular basis to ensure that the water level does not come into contact with your power package. Components on your engine will be damaged if submerged. Damage caused by submersion is not covered by the Mercury MerCruiser Limited Warranty.

## Basic Boat Operation (DTS Models)

### Launching and Boat Operation

**IMPORTANT:** Install bilge drain plug prior to launching boat.

#### CAUTION

To avoid possible ingestion of water that can damage engine components, do not turn the ignition key off when the engine is above idle speed. When launching your boat from a steep ramp, enter the water slowly. Do not use the lanyard stop switch to shut off the engine above idle speed. When coming off plane, if a large following wave may roll over the boat's transom, apply a short, light burst of throttle to minimize the wave action against the stern of the boat. Do not come off plane quickly, shift into reverse and shut off engine.

### OPERATION CHART

Operation Chart			
BEFORE STARTING	AFTER STARTING	WHILE UNDERWAY	AFTER STOPPING
Install bilge drain plug.	Observe all gauges to check condition of engine. If not normal, stop engine.	Observe all gauges to check condition of engine. If not normal, stop engine.	Turn ignition key to the "OFF" position.
Open engine hatch.	Check for fuel, oil, water, fluid and exhaust leaks.	Listen for the audio alarm.	Turn battery switch to the "OFF" position.
Turn battery switch on.	Check shift and throttle control operation.		Close fuel shut off valve.
Operate bilge blowers.	Check steering operation.		Close seacock, if equipped.
Open fuel shut off valve.			Flush cooling system if in saltwater.
Open seacock, if equipped.			Drain bilge.
Close the drain system.			
Check the engine oil.			
Perform all other checks specified by your dealer and/or boat builder.			
Listen for Audio Warning Alarm to sound when the ignition switch is in the "ON" position.			

### Starting and Stopping the Engine

MerCruiser DTS models are equipped with SmartStart. The SmartStart feature incorporates push button starting. Rather than holding the start button or key switch to start the engine and then releasing it when the engine starts, SmartStart completely controls the starting process. When the start button is pushed, the DTS system signals the engine PCM to start the engine. If the engine does not start, the starting process times out after eight seconds or when the engine reaches 400 RPM. Attempting to start the engine with the engine already running will turn the engine off.

#### STARTING THE ENGINE

1. Check all items listed in the Operation Chart.

2. Place the remote control handle in neutral.

**⚠ CAUTION**

Overheating from insufficient cooling water will cause engine and drive system damage. Ensure that there is sufficient water always available at water inlet holes during operation.

**⚠ WARNING**

Explosive gasoline fumes collect in the engine compartment. Avoid injury or property damage, operate the bilge blower for at least 5 minutes prior to starting the engine. If the boat is not equipped with a bilge blower, open the engine hatch and leave it open while starting the engine.

3. Turn ignition key to "RUN" position.
4. Turn the ignition key switch to the "START" position then release immediately, or depress the start/stop button, if equipped. The DTS control system will engage the starter until one of the following occurs:
  - a. Engine starts
  - b. 8 seconds elapses (3 seconds when there is no crank position sensor signal)
  - c. Control system detects a condition that makes starting the engine inappropriate
5. If the engine is cold, allow the engine to operate at idle for 1 to 2 minutes or until the engine temperature reaches 60 °C (140 °F).
6. Inspect the power package for fuel, oil, water, and exhaust leaks.
7. Move the control handle with a firm, quick motion forward to shift to forward gear, or backward to shift to reverse. After shifting, advance throttle to desired setting.

**⚠ CAUTION**

Avoid damage to the drive system. Shifting the drive system at RPMs greater than engine idle speed may cause internal damage to the drive system. Shift the drive system only when the engine is at idle RPM.

## STOPPING THE ENGINE

1. Move the remote control handle to neutral/idle and allow the engine to slow to idle speed. If engine has been operated at high speed for a long period of time, allow the engine to cool at idle speed for 3 to 5 minutes.
2. The engine can be stopped by any one of the following 4 methods:
  - a. Move the ignition key switch to the "ACCESSORY" or "OFF" position. The engine will stop and the control system will be deactivated.
  - b. Depress the start/stop button, if equipped. The engine will stop and the control system will remain active.
  - c. Momentarily move the ignition key switch to the "START" position, then release immediately. The control system will recognize that the engine is running and will stop the engine. The control system will remain active. Moving the ignition key switch to the "START" position again will issue a start request to the control system and the control system will start the engine, if appropriate.
  - d. Activate the lanyard stop switch, if equipped. The engine will stop, but the control system will remain active. The control system will not allow the engine to start if the lanyard stop switch is activated.

## Throttle Only Operation

**NOTE:** When operating in throttle only (neutral) mode, the DTS Control System will not allow the engine speed to increase above 3500 RPM.

**Zero effort remote controls:** Zero effort remote controls have separate throttle control and shift control levers. Advancing the throttle control lever beyond the idle position while the shift control lever is in the neutral position will cause engine speed to increase, but only up to the maximum neutral engine speed of 3500 RPM.

### WARNING

When using a Digital Throttle and Shift (DTS) Zero Effort shift control lever, the DTS Control System can shift the sterndrive unit or transmission at engine speeds greater than idle. The resulting forward or reverse motion of the boat at engine speeds greater than idle could be sudden and unexpected or create a hazardous situation, resulting in injury or death and property damage, caused by a loss of boat control. Always place the throttle control lever in the idle position before moving the DTS shift control lever into forward or reverse gear position.

**Panel Mount and Console Mount Remote Controls:** Panel mount and console mount remote controls are equipped with a throttle only button. To activate throttle only mode:

1. Refer to **Remote Controls** section for remote control features.
2. Move the control lever to the idle/neutral position.
3. Depress the throttle only button, and move the control lever to the idle/forward or idle/reverse position. The DTS control system will sound two beeps on the audio warning horn to indicate throttle only mode is active. On console mount remote controls, the neutral light will begin to blink.
4. Advancing the control lever beyond the idle/forward or idle/reverse position will cause engine speed to increase.

**IMPORTANT:** Moving the control lever back to the idle/neutral position will deactivate the throttle only mode and allow the engine to shift into gear.

5. Throttle only mode is deactivated by moving the control lever to the idle/neutral position. Moving the control lever from the idle/neutral position to the idle/forward or idle/reverse position without pressing the throttle only button will shift the unit into the chosen gear.

## Freezing Temperature Operation

**IMPORTANT:** If the boat is operated during periods of freezing temperature, precautions must be taken to prevent freeze damage to the power package. Damage caused by freezing is not covered by Mercury MerCruiser Limited Warranty.

## Drain Plug and Bilge Pump

The engine compartment in your boat is a natural place for water to collect. For this reason, boats are normally equipped with a drain plug and/or a bilge pump. It is very important to check these items on a regular basis to ensure that the water level does not come into contact with your power package. Components on your engine will be damaged if submerged. Damage caused by submersion is not covered by the Mercury MerCruiser Limited Warranty.

## Protecting People In The Water

### While You Are Cruising

It is very difficult for a person in the water to take quick action to avoid a boat heading in their direction, even at slow speeds.



Always slow down and exercise extreme caution any time you are boating in an area where there might be people in the water.

Whenever a boat is moving (even coasting) and the gear shift is in neutral, there is sufficient force by the water on the propeller to cause the propeller to rotate. This neutral propeller rotation can cause serious injury.

### While Boat Is Stationary

#### **⚠ WARNING**

**Stop your engine immediately whenever anyone in the water is near your boat. Serious injury to the person in the water is likely if contacted by a rotating propeller, a moving boat, a moving gearcase, or any solid device rigidly attached to a moving boat or gearcase.**

Shift into neutral and shut off the engine before allowing people to swim or be in the water near your boat.

## High-Speed And High-Performance Boat Operation

If your boat is considered a high-speed or high-performance boat with which you are unfamiliar, we recommend that you never operate it at its high speed capability without first requesting an initial orientation and demonstration ride with your dealer or an operator experienced with your boat. For additional information, refer to **Hi-Performance Boat Operation** booklet (90-849250-R2) from your dealer, distributor or Mercury Marine.

## Passenger Safety In Pontoon Boats And Deck Boats

Whenever the boat is in motion, observe the location of all passengers. Do not allow any passengers to stand or use seats other than those designated for traveling faster than idle speed. A sudden reduction in boat speed, such as plunging into a large wave or wake, a sudden throttle reduction, or a sharp change of boat direction, could throw them over the front of boat. Falling over the front of the boat between the two pontoons will position them to be run over.

### Boats Having An Open Front Deck

No one should ever be on the deck in front of the fence while the boat is in motion. Keep all passengers behind the front fence or enclosure.

Persons on the front deck could easily be thrown overboard or persons dangling their feet over the front edge could get their legs caught by a wave and pulled into the water.

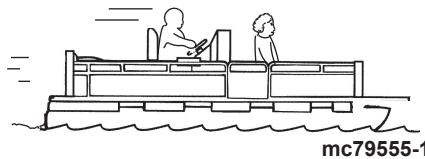
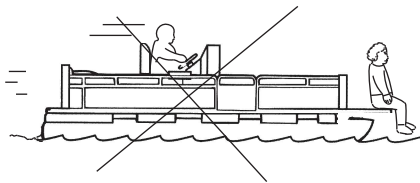

**⚠ WARNING**

**Avoid serious injury or death from falling over the front end of a pontoon or deck boat and being run over. Stay back from the front end of the deck and remain seated while the boat is in motion.**

### Boats With Front-Mounted, Raised Pedestal Fishing Seats

Elevated fishing seats are not intended for use when the boat is traveling faster than idle or trolling speed. Sit only in seats designated for traveling at faster speeds.

Any unexpected, sudden reduction in boat speed could result in the elevated passenger falling over the front of the boat.

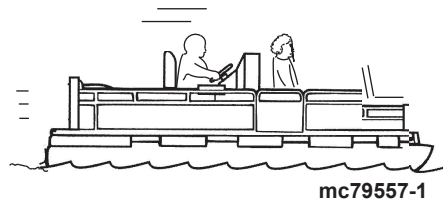
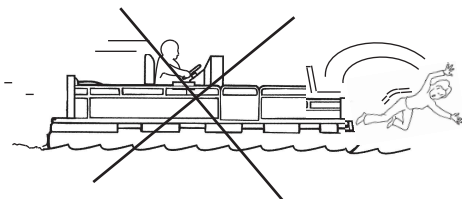

### Wave And Wake Jumping

**⚠ WARNING**

**Avoid serious injury or death from being thrown within or out of a boat when it lands after jumping a wave or wake. Avoid wave or wake jumping whenever possible. Instruct all occupants that if a wake or wave jump occurs, get low and hang on to a boat hand hold.**

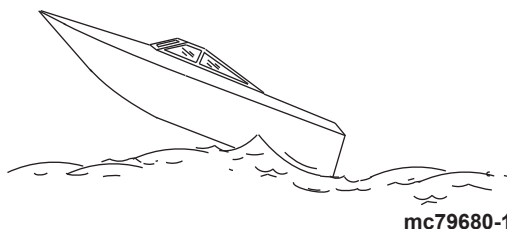

Operating recreational boats over waves and wakes is a natural part of boating. However, when this activity is done with enough speed to force the boat hull partially or completely out of the water, certain hazards arise, particularly when the boat re-enters the water.

The primary concern is the boat changing direction while in the midst of the jump. In such cases the landing may cause the boat to violently veer in a new direction. Such a sharp change in direction or turn can cause occupants to be thrown out of their seats or out of the boat.

There is another less common hazardous result from allowing your boat to launch off of a wave or wake. If the bow of your boat pitches down far enough while airborne, upon water contact it may penetrate under the water surface and submarine for an instant. This will bring the boat nearly to a stop in an instant and can send the occupants flying forward. The boat may also veer sharply to one side.

## Impact With Underwater Hazards

Reduce speed and proceed with caution whenever you're driving a boat in shallow water or in areas where the waters are suspected of having underwater obstacles that could be struck by the underwater drive components, rudder or the boat bottom.

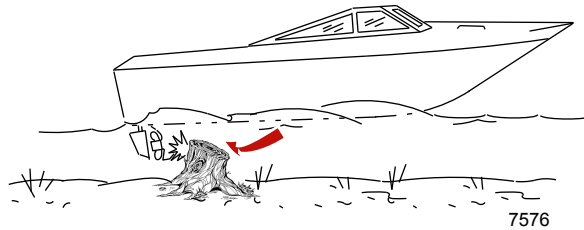

**IMPORTANT:** The most important thing you can do to help reduce injury or impact damage from striking a floating or underwater object is control the boat speed. Under these conditions, boat speed should be kept to a maximum speed of 24 to 40 km/h (15 to 25 MPH).

Striking a floating/underwater object may result in an infinite number of situations. Some of these situations could result in the following:

- The boat could move suddenly in a new direction. Such a sharp change in direction or turn can cause occupants to be thrown out of their seats or out of the boat.
- A rapid reduction in speed. This will cause occupants to be thrown forward, even out of the boat.
- Impact damage to the underwater drive components, rudder and/or boat.

Keep in mind, one of the most important things you can do to help reduce injury or impact damage in these situations is control the boat speed. Boat speed should be kept to a minimum planing speed when driving in waters known to have underwater obstacles.

After striking a submerged object, stop the engine as soon as possible and inspect the drive system for any broken or loose parts. If damage is present or suspected, the power package should be taken to an authorized Mercury MerCruiser dealer for a thorough inspection and necessary repair.

The boat should be checked for hull fractures, transom fractures and water leaks.

Operating with damaged underwater drive components, rudder or boat bottom could cause additional damage to other parts of the power package, or could affect control of the boat. If continued operation is necessary, do so at greatly reduced speeds.

### **WARNING**

**Avoid serious injury or death from loss of boat control. Continued boating with major impact damage can result in sudden component failure with or without subsequent impacts. Have the power package thoroughly inspected and any necessary repairs made.**



---

## Conditions Affecting Operation

### Weight Distribution (Passengers and Gear) Inside the Boat

#### Shifting weight to rear (stern):

- Generally increases speed and engine RPM
- Causes bow to bounce in choppy water
- Increases danger of following wave splashing into the boat when coming off plane
- At extremes, can cause the boat to porpoise

#### Shifting weight to front (bow):

- Improves ease of planing
- Improves rough water ride
- At extremes, can cause the boat to veer back and forth (bow steer)

### Bottom Of Boat

To maintain maximum speed, the boat bottom should be:

- Clean, free of barnacles and marine growth
- Free of distortion; nearly flat where it contacts the water
- Straight and smooth, fore and aft

Marine vegetation may accumulate when the boat is docked. This growth must be removed before operation; it may clog the water inlets and cause the engine to overheat.

### Cavitation

Cavitation occurs when water flow cannot follow the contour of a fast-moving underwater object, such as a gear housing or a propeller. Cavitation permits the propeller to speed up, but the boat speed to reduce. Cavitation can seriously erode the surface of the gear housing or the propeller. Common causes of cavitation are:

- Weeds or other debris snagged on the propeller
- Bent propeller blade
- Raised burrs or sharp edges on the propeller

### Ventilation

Ventilation is caused by surface air or exhaust gases that are introduced around the propeller resulting in propeller speed-up and a reduction in boat speed. Air bubbles strike the propeller blade and cause erosion of the blade surface. If allowed to continue, eventual blade failure (breakage) will occur. Excessive ventilation is usually caused by:

- Drive unit trimmed out too far.
- A missing propeller diffuser ring.
- A damaged propeller or gear housing, which allows exhaust gases to escape between propeller and gear housing.
- Drive unit installed too high on transom.

### Elevation And Climate

Elevation and climate changes will affect the performance of your power package. Loss of performance can be caused by:

- Higher elevations
- Higher temperatures
- Low barometric pressures
- High humidity

For you to have optimum engine performance under changing weather conditions, it is essential that the engine be propped to allow the engine to operate at or near the top end of the specified maximum RPM range with a normal boat load during your normal boating weather conditions.

In most cases, recommended RPM can be achieved by changing to a lower pitch propeller.

## Getting Started

### 20-Hour Break-In Period

**IMPORTANT: The first 20 hours of operation is the engine break-in period. Correct break-in is essential to obtain minimum oil consumption and maximum engine performance. During this break-in period, the following rules must be observed:**

- Do not operate below 1500 RPM for extended periods of time for the first 10 hours. Shift into gear as soon as possible after starting and advance the throttle above 1500 rpm if conditions permit safe operation.
- Do not operate at one speed consistently for extended periods.
- Do not exceed 3/4 throttle during the first 10 hours. During the next 10 hours, occasional operation at full throttle is permissible (5 minutes at a time maximum).
- Avoid full throttle acceleration from idle speed.
- Do not operate at full throttle until the engine reaches normal operating temperature.
- Frequently check engine oil level. Add oil as needed. It is normal for oil consumption to be high during the break-in period.

### After Break-In Period

To help extend the life of your Mercury MerCruiser power package, the following recommendations should be considered;

- Ensure that propeller allows the engine to operate at or near the top of the specified WOT RPM range (Refer to **Specifications** and **Maintenance**) when at full throttle with a normal boat load.
- Operation at 3/4 throttle setting or lower is recommended. Refrain from prolonged operation at WOT RPM.
- Change the engine oil and oil filter. Refer to **Maintenance**.
- Change the transmission oil and filter. Refer to **Maintenance** (ZF Transmission models).<sup>1</sup>.

### End of First Season Checkup

At the end of the first season of operation, contact an authorized Mercury MerCruiser dealer to discuss and/or perform scheduled maintenance items. If you are in an area where the product is operated continuously, year-round, you should contact your dealer at the end of the first 100 hours of operation or once yearly, whichever occurs first.

1. Require fluid and filter change after the first 25 hours and then every 100 hours.

## Section 4 - Specifications

### Table of Contents

---

Cruising RPM.....	44	Engine Specifications.....	46
Fuel Requirements.....	44	Tow Sports Models .....	46
Fuel Ratings .....	44	Inboard Models .....	47
Using Reformulated (Oxygenated) Gasolines		Fluid Specifications.....	47
(USA Only) .....	44	Engine .....	47
Gasolines Containing Alcohol .....	44	Transmission .....	48
Engine Oil.....	45		

---

## Cruising RPM

Modern inboard engines operate at higher engine speeds than those produced just a few years ago. This increased RPM along with better breathing is largely responsible for the significant increase in horsepower of these new engines. Along with the higher WOT RPM comes higher cruising RPM. This higher RPM is critical for optimum performance and efficiency. The materials and design of the new engines allow these higher speeds without durability penalty. In fact, over-propping the boat to reduce the cruising RPM to previous levels will increase the susceptibility to engine damage from detonation and pre-ignition. The recommended cruising RPM ranges are:

Cruising RPM for Peak Efficiency	
Model	RPM Range
350 MAG MPI	3400-3800
350 MAG MPI Horizon	3400-3800
MX 6.2L MPI	3600-4000

## Fuel Requirements

**IMPORTANT: Use of improper gasoline can damage your engine. Engine damage resulting from the use of improper gasoline is considered misuse of the engine, and damage caused thereby will not be covered under the limited warranty.**

### Fuel Ratings

Mercury MerCruiser engines will operate satisfactorily when using a major brand of unleaded gasoline meeting the following specifications:

**USA and Canada** - having a posted pump Octane Rating of 87 (R+M)/2 minimum. Premium gasoline [92 (R+M)/2 Octane] is also acceptable. Do not use leaded gasoline.

**Outside USA and Canada** - having a posted pump Octane Rating of 90 RON minimum. Premium gasoline (98 RON) is also acceptable. If unleaded gasoline is not available, use a major brand of leaded gasoline.

### Using Reformulated (Oxygenated) Gasolines (USA Only)

This type of gasoline is required in certain areas of the USA. The 2 types of oxygenates used in these fuels is Alcohol (Ethanol) or Ether (MTBE or ETBE). If Ethanol is the oxygenate that is used in the gasoline in your area, refer to Gasolines Containing Alcohol.

These Reformulated Gasolines are acceptable for use in your Mercury MerCruiser engine.

### Gasolines Containing Alcohol

If the gasoline in your area contains either methanol (methyl alcohol) or ethanol (ethyl alcohol), you should be aware of certain adverse effects that can occur. These adverse effects are more severe with methanol. Increasing the percentage of alcohol in the fuel can also worsen these adverse effects.

Some of these adverse effects are caused because the alcohol in the gasoline can absorb moisture from the air, resulting in a separation of the water/alcohol from the gasoline in the fuel tank.

The fuel system components on your Mercury MerCruiser engine will withstand up to 10% alcohol content in the gasoline. We do not know what percentage your boat's fuel system will withstand. Contact your boat manufacturer for specific recommendations on the boat's fuel system components (fuel tanks, fuel lines, and fittings). Be aware that gasolines containing alcohol may cause increased:

- Corrosion of metal parts
- Deterioration of rubber or plastic parts
- Fuel permeation through rubber fuel lines
- Starting and operating difficulties

**⚠ WARNING**

**FIRE AND EXPLOSION HAZARD:** Fuel leakage from any part of the fuel system can be a fire and explosion hazard which can cause serious bodily injury or death. Careful periodic inspection of entire fuel system is mandatory, particularly after storage. All fuel components should be inspected for leakage, softening, hardening, swelling or corrosion. Any sign of leakage or deterioration requires replacement before further engine operation.

Because of possible adverse effects of alcohol in gasoline, it is recommended that only alcohol-free gasoline be used where possible. If only fuel containing alcohol is available, or if the presence of alcohol is unknown, increased inspection frequency for leaks and abnormalities is required.

**IMPORTANT:** When operating a Mercury MerCruiser engine on gasoline containing alcohol, storage of gasoline in the fuel tank for long periods should be avoided. Long periods of storage, common to boats, create unique problems. In cars alcohol-blend fuels normally are consumed before they can absorb enough moisture to cause trouble, but boats often sit idle long enough for phase separation to take place. In addition, internal corrosion may take place during storage if alcohol has washed protective oil films from internal components.

## Engine Oil

To help obtain optimum engine performance and to provide maximum protection, we strongly recommend the use of the following oils listed in the order of recommendation:

1. MerCruiser / Quicksilver Synthetic Blend, NMMA FC-W rated, 4 cycle oil.
2. MerCruiser / Quicksilver 25W40 NMMA FC-W rated oil.
3. A NMMA FC-W rated oil.
4. MerCruiser / Quicksilver 4-cycle 25W40, non FC-W rated oil.
5. A good grade straight weight detergent automotive oil per the operating chart below.

**NOTE:** The use of non-detergent oils, multi-viscosity oils (other than as specified), non FC-W rated synthetic oils, low quality oils or oils that contain solid additives are specifically not recommended.

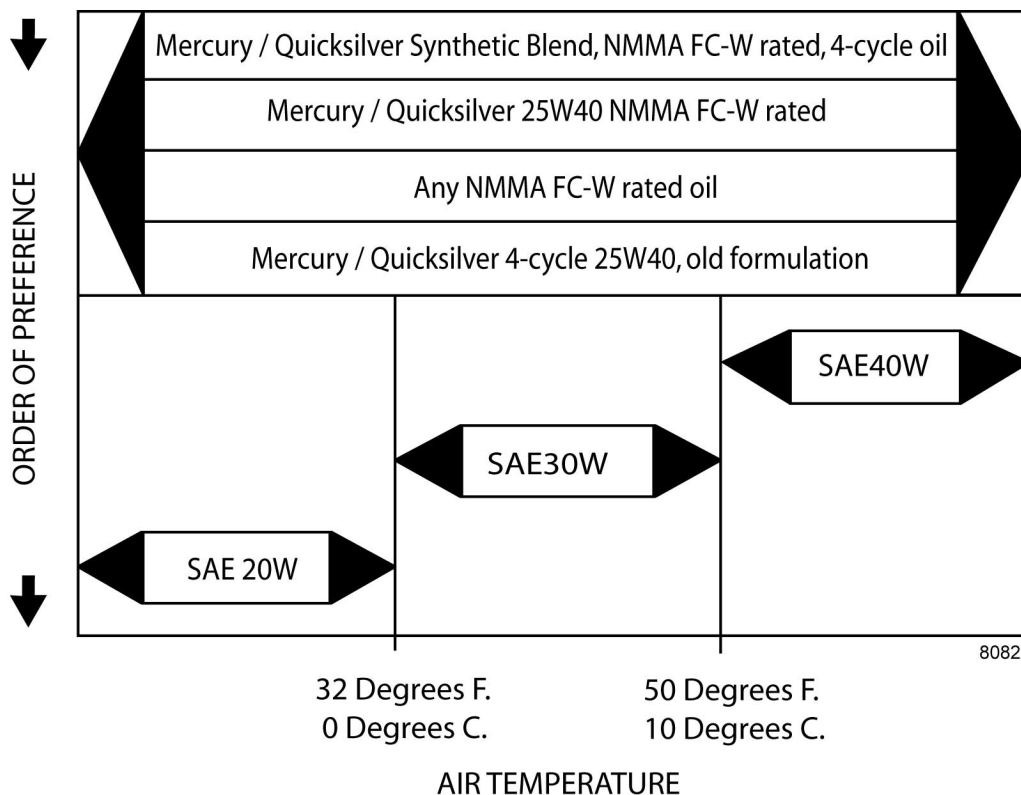

## Engine Specifications

### Tow Sports Models

Models	350 MAG MPI Tow Sports	MX 6.2 MPI Tow Sports
Horsepower <sup>1</sup> .	315	320
Kilowatts <sup>1</sup> .	235	239
Displacement	5.7 L (350cid)	6.2 L (377cid)
Specified WOT RPM Range <sup>2</sup> .	4600-5000	4800-5200
Idle RPM in Neutral <sup>2</sup> .	600 <sup>3</sup> .	
Minimum Oil Pressure @ Idle <sup>4</sup> .	41 kPa (6 psi)	
Minimum Oil Pressure @ 2000 RPM <sup>4</sup> .	124 kPa (18 psi)	
Thermostat, seawater cooled models	71° C (160° F)	
Thermostat, closed cooled models	77° C (170° F)	
Timing @ Idle <sup>3</sup> .	Not Adjustable	
Firing Order	1-8-4-3-6-5-7-2	
Electrical System	12 Volt Negative (-) Ground	
Alternator Rating - Hot Operating Amps	65 amp	

1. Performance obtained and corrected in accordance with SAE J1228/ISO 8665 Crankshaft Power.
2. Measured using an accurate service tachometer with the engine at normal operating temperatures.
3. Idle speed and timing on EFI models are not adjustable
4. Oil pressure must be checked with the engine at normal operating temperature.

Models	350 MAG MPI Tow Sports	MX 6.2 MPI Tow Sports
Alternator Rating - Cold Operating Amps	72 amp	
Recommended Battery Rating (Minimum)	750 CCA, 950 MCA, or 180 Ah	
Spark Plug Type	AC Platinum (AC 41-983)	
Spark Plug Gap	1.5 mm (0.060 in.)	

## Inboard Models

Models	350 MAG MPI	350 MAG MPI Horizon	MX 6.2 MPI	MX 6.2 MPI Horizon
Horsepower <sup>5</sup> .	300	300	320	320
Kilowatts <sup>5</sup> .	224	224	239	239
Displacement	5.7 L (350 cid)		6.2 L (377 cid)	
Specified WOT RPM Range <sup>6</sup> .	4600-5000		4800-5200	
Idle RPM in Neutral <sup>6</sup> .	600 <sup>7</sup> .			
Minimum Oil Pressure @ Idle <sup>8</sup> .	41 kPa (6 psi)			
Minimum Oil Pressure @ 2000 RPM <sup>8</sup> .	124 kPa (18 psi)			
Thermostat, seawater cooled models	71° C (160° F)			
Thermostat, closed cooled models	77° C (170° F)			
Timing @ Idle <sup>7</sup> .	Not Adjustable			
Firing Order	1-8-4-3-6-5-7-2			
Electrical System	12 Volt Negative (-) Ground			
Alternator Rating - Hot Operating Amps	65 amp			
Alternator Rating - Cold Operating Amps	72 amp			
Recommended Battery Rating (DTS Models) (Minimum)	750 CCA, 950 MCA, or 180 Ah			
Recommended Battery Rating (Non-DTS Models) (Minimum)	800 CCA, 1000 MCA, or 190 Ah			
Spark Plug Type	AC Platinum (AC 41-983)			
Spark Plug Gap	1.5 mm (0.060 in.)			

## Fluid Specifications

### Engine

**IMPORTANT: All capacities are approximate fluid measures.**

**IMPORTANT: It may be necessary to adjust oil levels depending on installation angle and cooling systems (heat exchanger and fluid lines).**

5. Performance obtained and corrected in accordance with SAE J1228/ISO 8665 Crankshaft Power.
6. Measured using an accurate service tachometer with the engine at normal operating temperatures.
7. Idle speed and timing on EFI models are not adjustable
8. Oil pressure must be checked with the engine at normal operating temperature.

## Specifications

All Models	Capacity	Fluid Type
Engine Oil (With Filter) <sup>1</sup> .	4.25 liters (4.5 U.S. qts)	Quicksilver Synthetic Blend, NMMA FC-W rated, 4 cycle oil
Seawater Cooling System <sup>2</sup> .	20 liters (21 U.S. qts)	Propylene Glycol and Purified Water
Closed Cooling System	19 liters (20 U.S. qts)	Mercury Extended Life Coolant/Antifreeze or Extended Life Ethylene Glycol 5/100 Antifreeze/ Coolant mixed 50/50 with Purified Water

## Transmission

Model	Capaci	Fluid Type
5000A	2.84L (3 qts)	Dexron III Automatic Transmission Fluid or Equivalent
5000V	3.30L (3-1/2 qts)	
71C In-Line	1.66L (1-3/4 qts)	Mobil 424 or Dexron III Automatic Transmission Fluid Do Not Mix!
71C Gear Reduction	2.84L (3 qts)	
71C Remote V-Drive	1.66L (1-3/4 qts)	
72C In-Line	1.66L (1-3/4 qts)	Mobil 424 or Universal Tractor H Mobil Hydraulic Oil Do Not Mix!
72C Gear Reduction	1.66L (1-3/4 qts)	
72C Remote V-Drive	1.66L (1-3/4 qts)	
72C V-Drive	3.79L (4 qts)	
63A	4.00L (4-1/2 qts)	Dexron III Automatic Transmission Fluid
63V	4.00L (4-1/2 qts)	
45C Tow Sports	1.77L (60 oz)	
45C Remote V-Drive <sup>3</sup> .	1.90L (64 oz)	
45C In-Line	1.94L (66 oz)	

1. Always use the dipstick to determine the exact quantity of oil or fluid required.
2. Seawater Cooling System capacity information is for winterization use only.
3. Refer to manufacturers owners manual for information concerning remote V-drive fluid capacities.



## Section 5 - Maintenance

### Table of Contents

Owner/Operator Responsibilities.....	50	Checking While Engine is Cold .....	57
Dealer Responsibilities.....	50	Changing .....	57
Maintenance.....	50	Engine Coolant.....	57
Do It Yourself Maintenance Suggestions.....	51	Checking .....	57
Inspection.....	51	Filling .....	58
Maintenance Schedule - Inboard Models.....	52	Changing .....	59
Routine Maintenance .....	52	Cleaning The Flame Arrestor.....	59
Each Day Start .....	52	Positive Crankcase Ventilation Valve (PCV)	
Each Day End .....	52	.....	60
Weekly .....	52	Changing .....	60
Every Two Months or 50 Hours .....	52	Changing Water Separating Fuel Filter.....	61
Scheduled Maintenance .....	52	GEN II Models .....	61
Every 100 Hours or Annually (Whichever		GEN III Models .....	62
Occurs First) .....	52	In-line Fuel Filter.....	64
Every 300 Hours or 3 Years .....	52	Lubrication.....	66
Every 5 Years .....	53	Throttle Cable.....	66
Maintenance Log.....	53	Transmission Linkage.....	66
Engine Oil.....	53	Serpentine Drive Belt.....	67
Checking .....	53	Checking .....	67
Filling .....	54	Replacing Belt and/or Adjusting Tension ....	68
Changing Oil and Filter .....	55	Flushing The Power Package.....	69
Easy Engine Oil Drain System .....	55	Inboards .....	69
Engine Oil Drain Pump .....	55	Tow Sports .....	70
Changing Filter .....	56	Battery.....	72
Transmission Fluid.....	57	Multiple EFI Engine Battery Precautions.....	73
Checking While the Engine is Warm .....	57		

## Owner/Operator Responsibilities

It is the operator's responsibility to perform all safety checks, to ensure that all lubrication and maintenance instructions are complied with for safe operation and to return the unit to an authorized Mercury MerCruiser dealer for a periodic checkup.

Normal maintenance service and replacement parts are the responsibility of the owner/operator and as such, are not considered defects in workmanship or material within the terms of the warranty. Individual operating habits and usage contribute to the need for maintenance service.

Proper maintenance and care of your power package will ensure optimum performance and dependability and will keep your overall operating expenses at a minimum. See your authorized Mercury MerCruiser dealer for service aids.

## Dealer Responsibilities

In general, a dealer's responsibilities to the customer include predelivery inspection and preparation such as:

- Ensure that the boat is properly equipped.
- Prior to delivery, make certain that the Mercury MerCruiser power package and other equipment are in proper operating condition.
- Make all necessary adjustments for maximum efficiency.
- Familiarize the customer with the on-board equipment.
- Explain and demonstrate the operation of the power package and boat.
- Provide you with a copy of a Predelivery Inspection Checklist.
- Your selling dealer should fill out the Warranty Registration Card completely and mail it to the factory immediately upon sale of the new product.

## Maintenance

<b>⚠ WARNING</b>
<b>Avoid injury or death and product damage from an electrical shock, fire or explosion. Always disconnect both battery cables from the battery before servicing the power package.</b>

<b>⚠ WARNING</b>
<b>Fuel vapors can be present in the engine compartment. Avoid injury or power package damage caused by fuel vapors or explosion. Always ventilate the engine compartment prior to servicing the power package.</b>

**IMPORTANT:** Refer to the maintenance schedule for complete listing of all scheduled maintenance to be performed. Some listings can be done by owner/operator, while others should be performed by an authorized Mercury MerCruiser dealer. Before attempting maintenance or repair procedures not covered in this manual, it is recommended that a Mercury MerCruiser Service Manual be purchased and read thoroughly.

*NOTE: Maintenance points are color coded for ease of identification. See the decal on engine for identification.*

Maintenance Point Color Codes	
Blue	Coolant

Maintenance Point Color Codes	
Yellow	Engine Oil
Orange	Fuel
Black	Gear Lube Oil (Sterndrive models only)
Brown	Transmission (Inboard models only)

## Do It Yourself Maintenance Suggestions

Present day marine equipment, such as your Mercury MerCruiser power package, are highly technical pieces of machinery. Electronic ignition and special fuel delivery systems provide greater fuel economies, but also are more complex for the untrained mechanic.

If you are one of those persons who likes to do it yourself, here are some suggestions for you.

- Do not attempt any repairs unless you are aware of the Cautions, Warnings and procedures required. Your safety is our concern.
- If you attempt to service the product yourself, we suggest you order the service manual for that model. The service manual outlines the correct procedures to follow. It is written for the trained mechanic, so there may be procedures you don't understand. Do not attempt repairs if you do not understand the procedures.
- There are special tools and equipment that are required to perform some repairs. Do not attempt these repairs unless you have these special tools and/or equipment. You can cause damage to the product in excess of the cost a dealer would charge you.
- Also, if you partially disassemble an engine or drive assembly and are unable to repair it, the dealer's mechanic must reassemble the components and test to determine the problem. This will cost you more than taking it to the dealer immediately upon having a problem. It may be a very simple adjustment to correct the problem.
- Do not telephone the dealer, service office or the factory to attempt for them to diagnose a problem or to request the repair procedure. It is difficult for them to diagnose a problem over the telephone.

Your authorized dealer is there to service your power package. They have qualified factory trained mechanics.

It is recommended you have the dealer do periodic maintenance checks on your power package. Have them winterize it in the fall and service it before the boating season. This will reduce the possibility of any problems occurring during your boating season when you want trouble free boating pleasure.

## Inspection

Inspect your power package often, and at regular intervals, to help maintain its top operating performance and correct potential problems before they occur. The entire power package should be checked carefully, including all accessible engine parts.

- Check for loose, damaged or missing parts, hoses and clamps; tighten or replace as necessary.
- Check plug leads and electrical leads for damage.
- Remove and inspect the propeller. If badly nicked, bent or cracked, contact your authorized Mercury MerCruiser dealer.
- Repair nicks and corrosion damage on power package exterior finish. Contact your authorized Mercury MerCruiser dealer.

## Maintenance Schedule - Inboard Models

### Routine Maintenance

*NOTE: Only perform maintenance which applies to your particular power package.*

#### EACH DAY START

- Check the crankcase oil (interval can be extended based on experience).
- Check the transmission fluid level.

#### EACH DAY END

- If operating in salt, brackish or polluted waters, flush the cooling system after each use.

#### WEEKLY

- Check the water inlets for debris or marine growth. Check the seawater strainer and clean.
- Check the coolant level.
- Check the transmission fluid.

#### EVERY TWO MONTHS OR 50 HOURS

- Operating in saltwater or brackish or polluted water only: treat the power package with Corrosion Guard.
- Check the battery connections and the fluid level.
- Ensure that the gauges and the wiring connections are secure. Clean the gauges.<sup>1</sup>

### Scheduled Maintenance

*NOTE: Only perform maintenance which applies to your particular power package.*

#### EVERY 100 HOURS OR ANNUALLY (WHICHEVER OCCURS FIRST)

- Touch-up the paint on the power package.
- Change the crankcase oil and filter.
- Change the transmission fluid (ZF Transmission Models)<sup>2</sup>.
- Replace the water separating fuel filter element.
- Check the steering system and the remote control for loose, missing or damaged parts. Lubricate the cables and the linkages.
- Inspect the condition of the belts.
- Clean the flame arrestor, IAC muffler (MPI engines), and the crankcase ventilation hoses. Inspect the PCV valve, if equipped.

#### EVERY 300 HOURS OR 3 YEARS

- Check the engine mount for tightness and retorque if necessary.
- Check the distributor cap, if equipped.
- Check the electrical system for loose, damaged, or corroded fasteners.
- Check the cooling system and the exhaust system hose clamps for tightness. Inspect both systems for damage or leaks.
- Disassemble and inspect the seawater pump and replace worn components.
- Clean the seawater section of the closed cooling system. Clean, inspect, and test the pressure cap.
- Inspect the exhaust system components and verify that the flapper valves are not missing or worn, if equipped.

1. If operating in saltwater, interval is reduced to every 25 hours or 30 days whichever occurs first.

2. Require fluid and filter change after the first 25 hours and then every 100 hours.

**EVERY 5 YEARS**

- Replace the coolant (every two years if extended life antifreeze coolant is not being used).

**Maintenance Log**

Record all maintenance performed on your power package here. Be sure to save all work orders and receipts.

Date	Maintenance Performed	Engine Hours

**Engine Oil****⚠ CAUTION**

**ENVIRONMENTAL HAZARD!** Discharge of oil or oil waste into the environment is restricted by law. Do not spill oil or oil waste into the environment when using or servicing your boat. Contain and dispose of oil or oil waste as defined by local authorities.

**Checking**

1. Stop the engine. Allow approximately 5 minutes for the oil to drain into the oil pan. The boat must be at rest in the water.
2. Remove the dipstick. Wipe clean and reinstall fully into the dipstick tube. Wait 60 seconds to allow trapped air to vent.

**NOTE:** Ensure that dipstick is installed with oil level indication marks facing the rear of the engine (flywheel end).

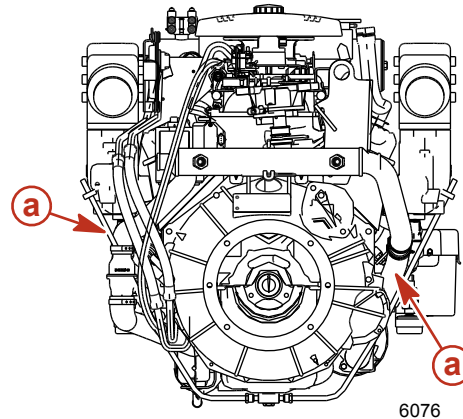

**a** - Dipstick tube

**IMPORTANT:** Add the specified engine oil to bring the level up to, but not over, the full or OK range mark on the dipstick.

3. Remove the dipstick and observe the oil level. Oil level must be between full or OK range and add. Reinstall dipstick into dipstick tube.

## Filling

**IMPORTANT:** Do not overfill the engine with oil.

**IMPORTANT:** Always use the dipstick to determine the exact quantity of oil or fluid required.

1. Remove oil fill cap.

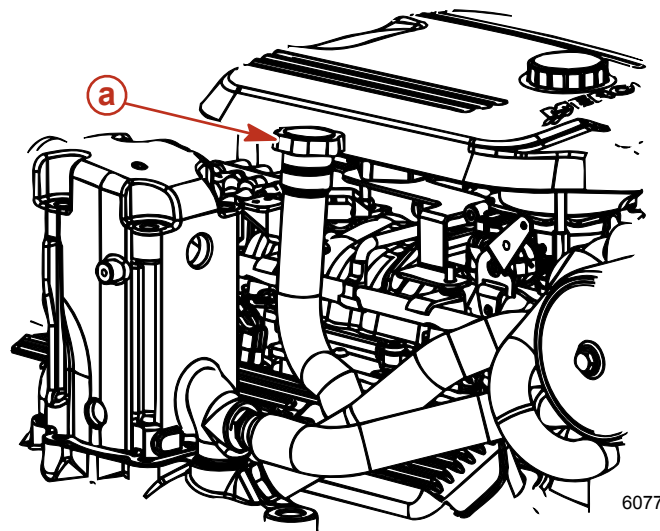

**a** - Oil fill cap

**IMPORTANT:** Add the specified engine oil to bring the level up to, but not over, the full or OK range mark on the dipstick.

2. Add the specified engine oil to bring the level up to, but not over, the full or OK range mark on the dipstick. Recheck oil level.
3. Replace the fill cap.

Models	Capacity	Fluid Type
Engine Oil (With Filter)	4.25 liters (4.5 U.S. Quart)	Mercury/Quicksilver Synthetic Blend MerCruiser Engine Oil 25W-40

## Changing Oil and Filter

Refer to the Maintenance schedule for the change interval. Engine oil should be changed before placing the boat in storage.

**IMPORTANT:** Change engine oil when the engine is warm from operation. Warm oil flows more freely, carrying away more impurities. Use only recommended engine oil (refer to Specifications).

### EASY ENGINE OIL DRAIN SYSTEM

*NOTE: Boat must be out of water to perform this procedure.*

1. Loosen the oil filter to vent the system.
2. Remove the bilge drain plug.
3. Pull tether through the bilge drain.

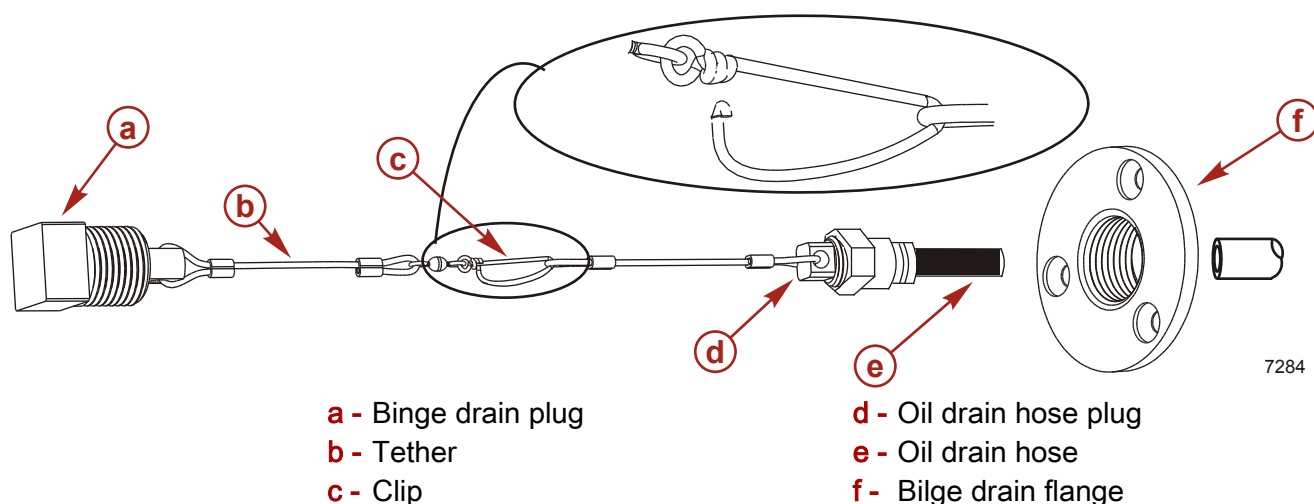

4. Place the oil drain hose in a suitable container.
5. Remove the drain plug from the oil drain hose.
6. After oil has drained completely, install the drain plug in the oil drain hose.
7. Push the hose through bilge drain and install the plug.

### ENGINE OIL DRAIN PUMP

1. Loosen the oil filter to vent the system.
2. Remove the dipstick.

3. Install the oil pump onto the dipstick tube.

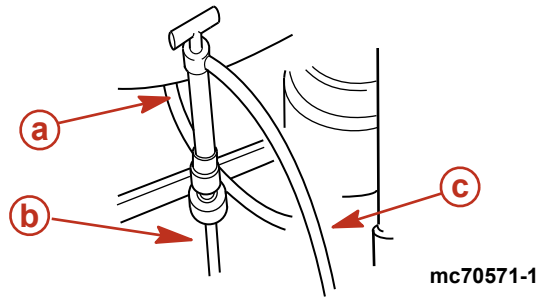

- a - Typical oil pump
- b - Dipstick tube
- c - Oil drain hose

4. Insert the hose end of the crankcase oil pump onto an appropriate container and, using the handle, pump until the crankcase is empty.
5. Remove the pump.
6. Install the dipstick.

**CHANGING FILTER**

1. Remove and discard oil filter.

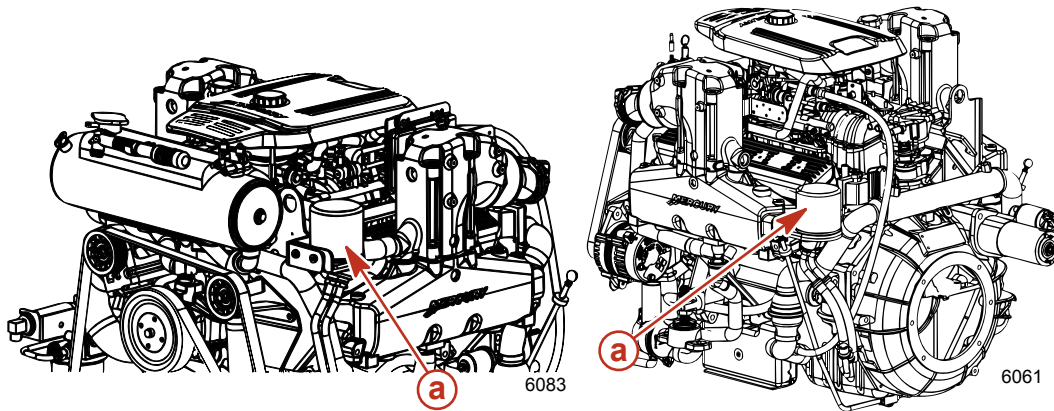

**In-line exhaust**

**V-drive exhaust**

- a - Oil filter

2. Coat sealing ring on new filter with engine oil and install.
3. Tighten oil filter securely (following filter manufacturer's instructions). Do not overtighten.
4. Remove oil fill cap.

**IMPORTANT:** Always use dipstick to determine exactly how much oil is required.

5. Add recommended engine oil to bring level up to the bottom of the OK range on the dipstick.
6. With the boat at rest in the water, check the oil level and add specified fluid to bring the oil level up to, but not over, the full or OK range.

**NOTE:** Adding 0.95 liters (1 quart) of engine oil will raise the level from the add mark to the top of the OK range.

Models	Capacity	Fluid Type
Engine Oil (With Filter)	4.25 liters (4.5 U.S. Quart)	Mercury/Quicksilver Synthetic Blend MerCruiser Engine Oil 25W-40



7. Start the engine, run the engine for three minutes, and check for leaks. Stop the engine. Allow approximately 5 minutes for the oil to drain into the oil pan. The boat must be at rest in the water.

## Transmission Fluid

### Checking While the Engine is Warm

1. Velvet Drive Transmissions - Stop the engine and immediately check fluid level by turning T-handle counterclockwise, to remove dipstick. Fluid level should be up to full mark. If low, add specified fluid through dipstick tube on transmissions.
2. ZF Marine Transmissions - Stop the engine and remove the dipstick to check level. If fluid is below top (full) line, add specified fluid through dipstick hole. Do not overfill. Reinstall dipstick with cap fully seated.
3. Walter V-Drive Transmissions - Stop the engine and remove the dipstick to check the level. If the fluid is below the top (full) line, add the specified fluid through the breather elbow. Do not overfill. Reinstall the dipstick with the cap fully seated.

### Checking While Engine is Cold

**NOTE:** Cold fluid level check: To ease checking the fluid level, the dipstick can be marked or scribed with a cold level mark.

1. Follow the procedure for the warm fluid level check, then allow the boat to sit overnight.

**IMPORTANT:** Be sure to push the dipstick all the way down into the dipstick tube when checking the fluid level.

2. Remove the dipstick, wipe clean and reinsert.
3. Remove the dipstick, observe the fluid level and mark the cold fluid level.
4. Reinstall the dipstick, tighten the T-handle securely. Do not overtighten.

## Changing

Contact your authorized Mercury MerCruiser dealer.

## Engine Coolant

### Checking

#### WARNING

Allow the engine to cool down before removing the coolant pressure cap. A sudden loss of pressure could cause hot coolant to boil and discharge violently. After the engine has cooled, turn the cap 1/4 turn to allow any pressure to escape slowly, then push down and turn the cap all the way off.

1. Remove the cap from the heat exchanger and observe the fluid level.

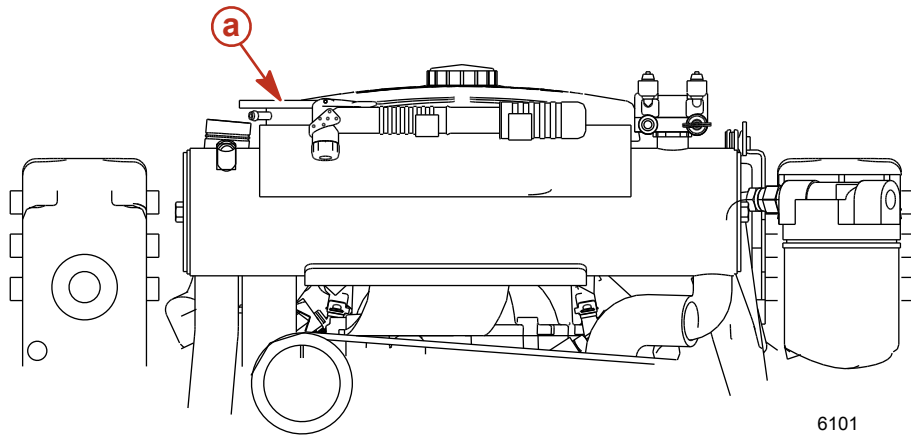

a - Heat exchanger cap

2. The coolant level in the heat exchanger should be at the bottom of the filler neck. If the coolant level is low, contact your authorized Mercury MerCruiser dealer.
  3. Install the cap onto the heat exchanger.
- IMPORTANT: When reinstalling the pressure cap, be sure to tighten it until it seats on the filler neck.**
4. With the engine at normal operating temperature, check the coolant level in the coolant recovery bottle.
  5. The coolant level should be between the "ADD" and "FULL" marks.

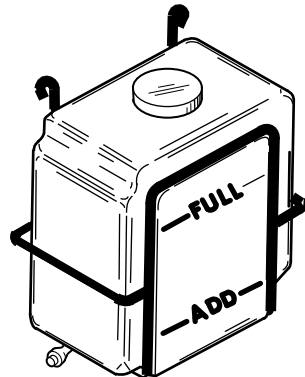

6102

6. Add the specified fluid as necessary.

Tube Ref No.	Description	Where Used	Part No.
 122	Extended Life Antifreeze/ Coolant	Closed Cooling System	92-877770K1

## Filling

**⚠ CAUTION**

Alcohol or Methanol based antifreeze or plain water, are not recommended for use in the coolant section of the Closed Cooling System at any time.

**⚠ CAUTION**

Overheating from insufficient cooling water will cause engine and drive system damage. Ensure that there is sufficient water always available at water inlet holes during operation.

**⚠ CAUTION**

Air trapped in the closed cooling section of an engine cooling system can cause the engine to overheat resulting in engine damage. To minimize the possibility of trapping air when initially filling the closed cooling system, position the boat so that the front of the engine is higher than the rear of the engine.

*NOTE: Add coolant only when engine is at normal operating temperature.*

1. Remove the fill cap from the coolant recovery bottle.
2. Fill to the "FULL" line with the specified coolant.

Tube Ref No.	Description	Where Used	Part No.
 122	Extended Life Antifreeze/ Coolant	Closed Cooling System	92-877770K1

3. Install the fill cap onto the coolant recovery bottle.

## Changing

Contact your authorized Mercury MerCruiser dealer.

## Cleaning The Flame Arrestor

**⚠ WARNING**

Avoid gasoline fire or explosion. Gasoline is extremely flammable and highly explosive under certain conditions. Be careful when cleaning flame arrestor; ensure that ignition is off. Do not smoke or allow sources of spark or open flame in area when cleaning flame arrestor.

1. Remove the engine cover.
2. Disconnect and remove the crankcase ventilation hose from the fitting on the flame arrestor and valve cover.
3. Remove the flame arrestor.

**⚠ WARNING**

Avoid gasoline fire or explosion. Gasoline is extremely flammable and highly explosive under certain conditions. Never use gasoline as a cleaning solvent.

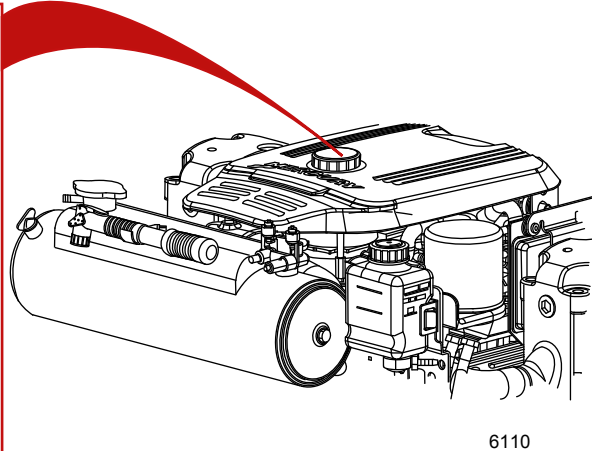
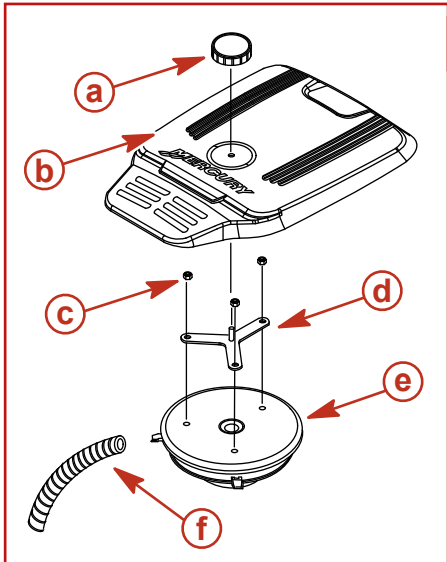

6110

- a** - Engine cover knob
- b** - Engine cover
- c** - Nuts, flame arrestor
- d** - Cover mount bracket
- e** - Flame arrestor
- f** - Crankcase ventilation hose

4. Clean the flame arrestor with warm water and a mild detergent.
5. Inspect the flame arrestor for holes, cracks or deterioration. Replace if necessary.
6. Allow the flame arrestor to air dry completely before use.
7. Clean the crankcase ventilation hose with warm water and a mild detergent. Dry with compressed air or allow to air dry completely.
8. Inspect the crankcase ventilation hose for cracks or deterioration. Replace if necessary.
9. Install the flame arrestor and flame arrestor bracket. Torque the flame arrestor bracket nuts.

Description	Nm	lb. in.	lb. ft.
Flame arrestor bracket nut	12	106	

10. Connect the crankcase ventilation hose to the fitting on the flame arrestor and valve cover.
11. Install the engine cover.

## Positive Crankcase Ventilation Valve (PCV) CHANGING

**IMPORTANT:** Use only Mercury MerCruiser replacement parts to ensure compliance with emission regulations.

**NOTE:** On V6 models the PCV valve is non-serviceable and is an internal component of the valve cover.

1. Remove the PCV valve from the port valve cover.

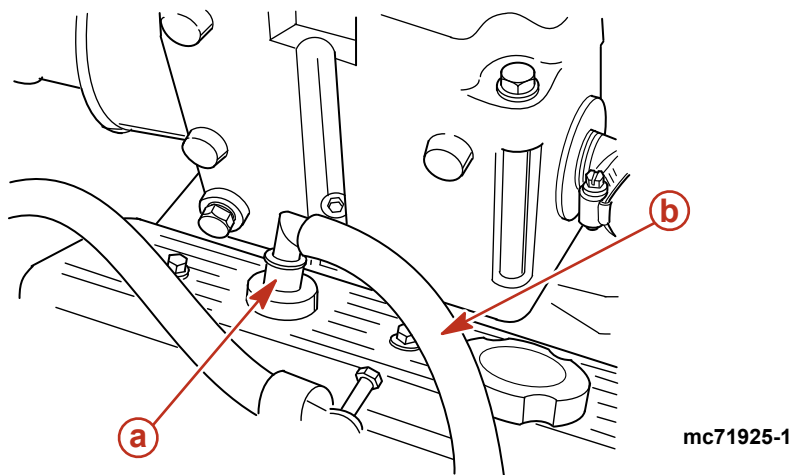

a - PCV valve

b - Hose

2. Disconnect the PCV valve from the hose and discard the valve.
3. Install a new PCV valve in the valve cover and reconnect the hose.
4. Ensure the PCV valve is tightly seated in the valve cover.

## Changing Water Separating Fuel Filter

### ▲ WARNING

Avoid serious injury or death from a gasoline fire or explosion; gasoline is extremely flammable and highly explosive under certain conditions. When servicing the fuel system components ensure that the engine is cool, the ignition switch is in the off position, and that the lanyard stop switch, if equipped, is in the off position. Do not smoke or allow spark or open flame in the area. Wipe up any spilled fuel immediately. Ensure that no fuel leaks exist before closing the engine hatch.

### GEN II Models

1. Allow the engine to cool down.
- NOTE:** Mercury MerCruiser recommends that the engine be shut off for 12 hours prior to filter removal.
2. Close fuel supply valve, if equipped.
  3. Wrap the water separating fuel filter with a cloth to help catch any fuel spills or spray.
  4. Remove and discard the water separating fuel filter and sealing ring from the mounting bracket.
  5. Coat the sealing ring on the new filter with engine oil.

Tube Ref. No.	Description	Where Used	Part No.
	Synthetic Blend MerCruiser Engine Oil SAE25W-40	Filter sealing ring	92-883725K01

6. Thread filter onto the mounting bracket and tighten securely by hand. Do not use a filter wrench.

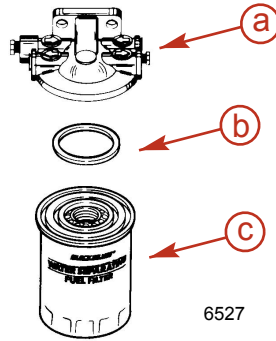

- a** - Fuel filter mounting bracket                      **c** - Fuel filter  
**b** - Sealing ring

7. Open fuel supply valve, if equipped.
8. Ensure that engine compartment is properly ventilated.
9. Supply cooling water to the engine.
10. Start the engine. Check for gasoline leaks around the fuel filter assembly. If leaks exist, stop the engine immediately. Recheck the filter installation, wipe up any spilled fuel, and properly ventilate the engine compartment. If leaks continue, stop engine immediately and contact your authorized Mercury MerCruiser dealer.

## GEN III Models

1. Allow the engine to cool down.  
**NOTE:** Mercury MerCruiser recommends that the engine be shut off for 12 hours prior to filter removal.
2. Close fuel supply valve, if equipped.
3. Disconnect the Cool Fuel Module harness from the engine wiring harness.
4. Turn the key switch to the start position and allow the starter to operate for 5 seconds.
5. Turn key switch to off position.

6. Loosen each filter assembly retaining screw until the screw is disengaged from the Cool Fuel Module. Do not remove the filter assembly retaining screws from the filter cap.

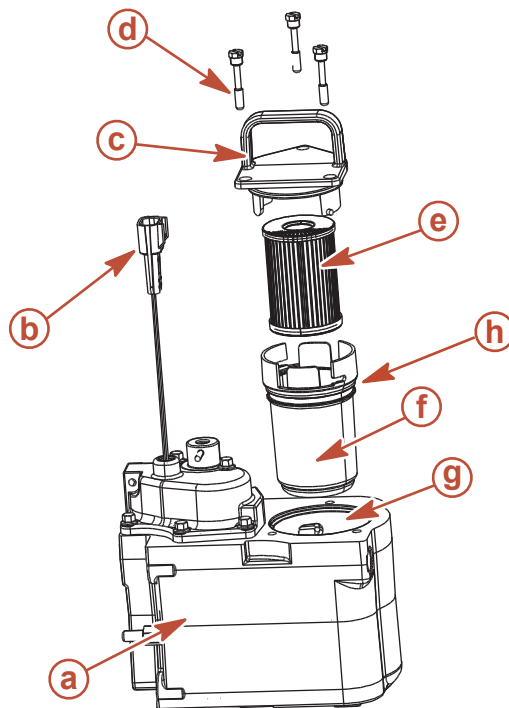

8837

- |  |  |
|--|--|
| <b>a</b> - Cool Fuel Module                | <b>e</b> - Fuel filter element               |
| <b>b</b> - Cool Fuel Module harness        | <b>f</b> - Filter cup                        |
| <b>c</b> - Filter cap                      | <b>g</b> - Cool Fuel Module filter reservoir |
| <b>d</b> - Filter assembly retaining screw | <b>h</b> - O-ring                            |

7. Unseat the filter assembly by grasping the filter assembly handle and pulling upward. Do not remove the filter assembly from the Cool Fuel Module at this time.
8. Allow any fuel that may be in the filter assembly to drain out through the bottom of the filter assembly and into the Cool Fuel Module filter reservoir.
9. Remove the filter cup from the filter cap by grasping the filter cap and rotating it in a clockwise direction while holding the filter cup stationary.
10. Remove the used water separating fuel filter element from the filter cup, place it in a clean, approved container.
11. Dispose of any water or debris that may be in the filter cup.
12. Install a new water separating fuel filter element into the filter cup. Push the element into the cup until completely seated.
13. Install new O-ring on the filter cup.
14. Attach the filter cap to the filter cup by grasping the filter cap and rotating it in a counter clockwise direction while holding the filter cup stationary, until the filter cap locks securely into place.
15. Install the fuel filter assembly slowly into the Cool Fuel Module to prevent spilling fuel, and align the screws retained in the filter cap with the screw holes in the Cool Fuel Module. Tighten the filter assembly retaining screws until hand tight.
16. Ensure that the filter cap is firmly seated against the Cool Fuel Module and torque each filter assembly retaining screw.

Description	Nm	lb. in.	lb. ft.
Filter assembly retaining screw	6	53	

17. Open fuel supply valve, if equipped.
18. Reconnect the Cool Fuel Module harness to the engine wiring harness.
19. Supply cooling water to the engine.
20. Properly ventilate the engine compartment.
21. Start the engine. Check for gasoline leaks around the fuel filter assembly. If leaks exist, stop the engine immediately. Recheck the filter installation, clean spilled fuel and properly ventilate the engine compartment. If leaks continue, stop engine immediately and contact your authorized Mercury MerCruiser dealer.

## In-line Fuel Filter

⚠ WARNING
<p>Avoid serious injury or death from a gasoline fire or explosion; gasoline is extremely flammable and highly explosive under certain conditions. When servicing the fuel system components ensure that the engine is cool, the ignition switch is in the off position, and that the lanyard stop switch, if equipped, is in the off position. Do not smoke or allow spark or open flame in the area. Wipe up any spilled fuel immediately. Ensure that no fuel leaks exist before closing the engine hatch.</p>

1. Allow the engine to cool down.
- NOTE:** Mercury MerCruiser recommends that the engine be shut off for 12 hours prior to filter removal.
2. Close fuel supply valve, if equipped.
  3. Wrap the water separating fuel filter with a cloth to help catch any fuel spills or spray.
  4. Remove and discard the in-line fuel filter.
  5. Select appropriate size connector for the fuel line and install the connector on the new filter.
  6. Apply sealant to the male pipe threads on the connectors.

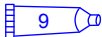
Tube Ref No.	Description	Where Used	Part No.
	Loctite 567 PST Pipe Sealant	Male threads	92-809822

7. Torque each connector using a backup wrench on the hex fitting nearest to the connector.

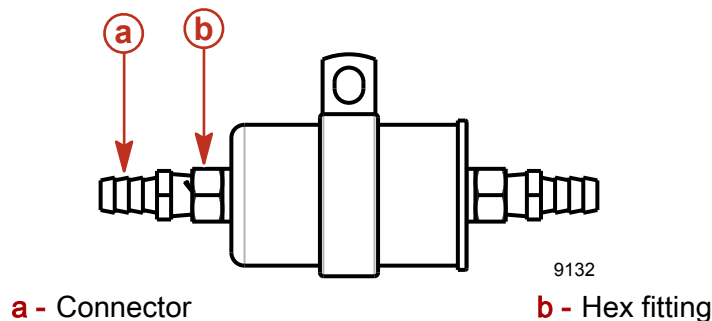

Description	Nm	lb. in.	lb. ft.
Connectors	19-27		14-20



8. Insert filter into mounting clip.

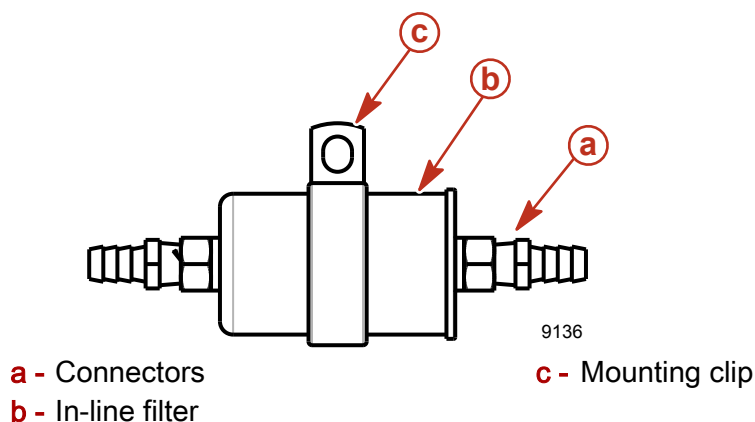

9. Install and torque screw and washer through the mounting clip into the stringer.

Description	Nm	lb. in.	lb. ft.
Mounting clip screw	12.2		9

10. Insert the hoses onto the barb fittings and fasten using hose clamps.

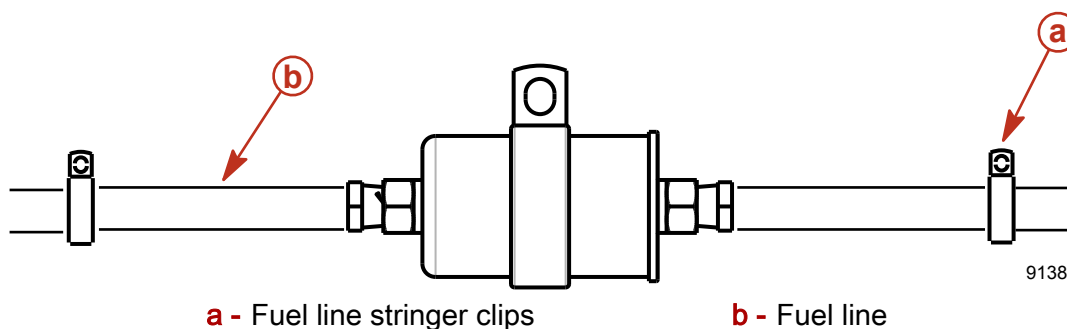

Description	Nm	lb. in.	lb. ft.
Hose clamps	3.4-6.8	30-60	

11. Open fuel supply valve, if equipped.

12. Ensure that engine compartment is properly ventilated.

13. Supply cooling water to the engine.

14. Start the engine. Check for gasoline leaks around the fuel filter assembly. If leaks exist, stop the engine immediately. Recheck the filter installation, clean spilled fuel and properly ventilate the engine compartment. If leaks continue, stop engine immediately and contact your authorized Mercury MerCruiser dealer.

# Lubrication

## Throttle Cable

1. Lubricate the pivot points and the guide contact surfaces.

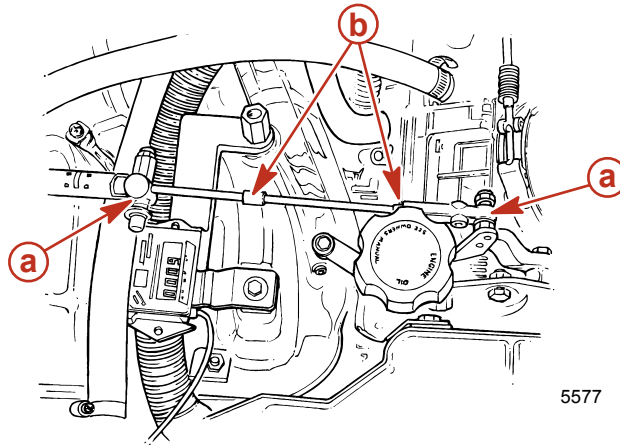

**a** - Pivot points

**b** - Guide contact surfaces

Tube Ref. No.	Description	Where Used	Part No.
	Synthetic Blend MerCruiser Engine Oil SAE25W-40	Throttle cable pivot points & guide contact surfaces	92-883725K01

## Transmission Linkage

**IMPORTANT:** The poppet ball must be centered in the detent hole for each F-N-R position.

1. Lubricate the detent ball and the holes in the shift lever.

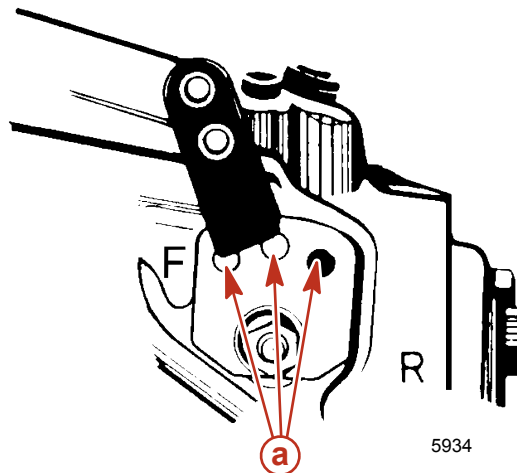

**In-Line Transmission**

Tube Ref. No.	Description	Where Used	Part No.
	Synthetic Blend MerCruiser Engine Oil SAE25W-40	Detent ball and shift lever holes	92-883725K01

- Lubricate the shift cable pivot points.

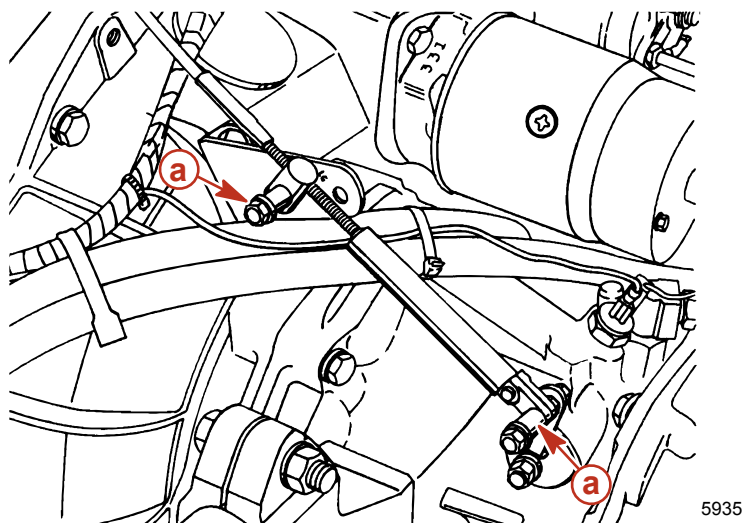

**a** - Pivot points

Tube Ref. No.	Description	Where Used	Part No.
	Synthetic Blend MerCruiser Engine Oil SAE25W-40	Shift cable pivot points	92-883725K01

## Serpentine Drive Belt

### ⚠ WARNING

Avoid possible serious injury. Make sure engine is shut off and ignition key is removed before inspecting belt.

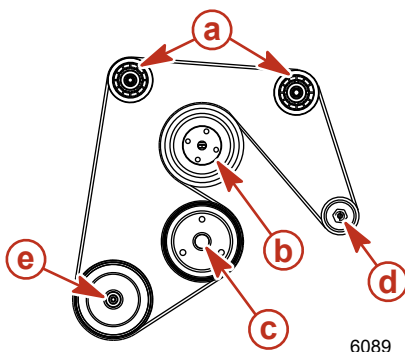

- 6089
- a** - Idler pulley
  - b** - Circulating pump pulley
  - c** - Crankshaft pulley
  - d** - Alternator pulley
  - e** - Seawater pump pulley

## Checking

- Inspect the drive belt for proper tension and for the following:
  - Excessive wear
  - Cracks

**NOTE:** Minor, transverse cracks (across the belt width) may be acceptable. Longitudinal cracks (in the direction of belt length) that join transverse cracks are NOT acceptable.

- Fraying

- Glazed surfaces
- Proper tension - 13 mm (1/2 in.) deflection, with moderate thumb pressure, on the belt at the location that has the longest distance between two pulleys.

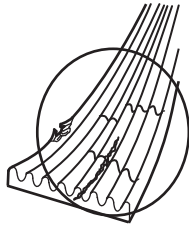

mc75130-1

## Replacing Belt and/or Adjusting Tension

**IMPORTANT:** If a belt is to be reused, it should be installed in the same direction of rotation as before.

**NOTE:** Belt deflection is to be measured on the belt at the location that has the longest distance between two pulleys.

1. Loosen the 16 mm (5/8 in.) locking nut on the adjustment stud.
2. Turn the adjustment stud and loosen the belt.
3. If a new serpentine drive belt is required, remove the old belt and install a new belt onto the pulleys.
4. Put a wrench on the adjustment stud 16 mm (5/8 in.) locking nut.
5. Use a 8 mm (5/16 in.) socket and tighten adjusting the stud to adjust the belt deflection.
6. Using one of the 2 methods following, check for correct deflection.
  - a. Push down with moderate thumb pressure on the longest stretch of belt. Proper deflection is 13 mm (1/2 in.).
  - b. Attach the Kent Moore© Belt Tension Gauge to the belt. The gauge has different ranges for new and used belts.

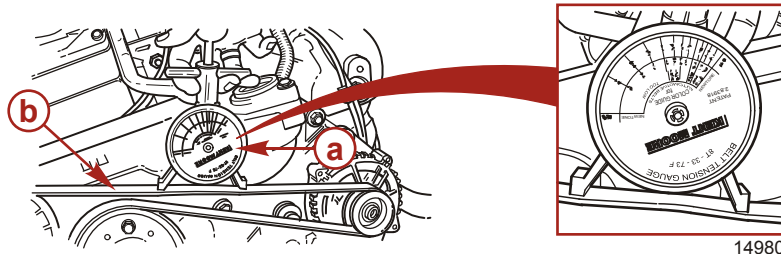

a - Kent Moore© Tension Gauge

b - Serpentine belt

7. While holding the adjustment stud at the correct belt tension, tighten the 16 mm (5/8 in.) locking nut.

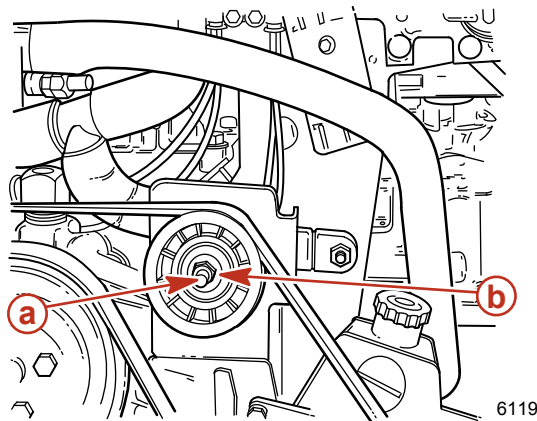

**a** - 8 mm (1/16 in.) adjusting stud

**b** - 16 mm (5/8 in.) locking nut

8. Operate the engine for a short period of time and recheck the belt adjustment.

## Flushing The Power Package

### Inboards

**NOTE:** Flushing is needed only for salty, brackish, mineral laden or polluted water applications. Flushing is recommended after each outing for best results.

1. Close the seacock, if equipped, or remove the water inlet hose and plug the inlet.
2. Drain the seawater from the engine.
3. Attach the quick connect fitting to a water hose.
4. Open the water source completely.
5. Remove the blue cap from the flush socket on the engine

#### ⚠ CAUTION

Overheating from insufficient cooling water will cause engine and drive system damage. Ensure that there is sufficient water always available at water inlet holes during operation.

#### ⚠ CAUTION

Do not let water run more than 15 seconds with engine not operating or too much flushing water will collect in the muffler.

6. Snap the quick connect fitting and the water hose into the flush socket on the engine.

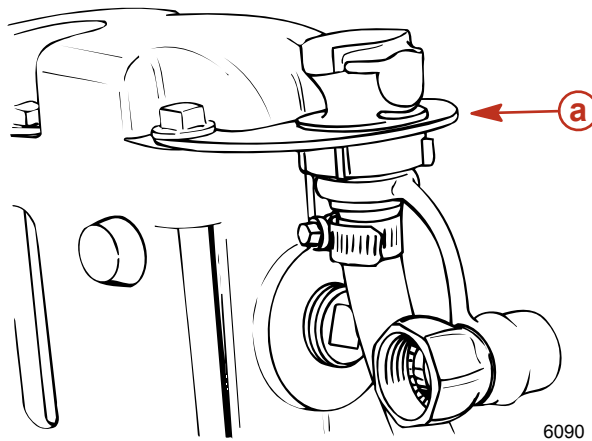

**a** - Quick connect fitting

7. Start the engine within 15 seconds.
8. Operate the engine between 600 RPM and 800 RPM. Do NOT exceed 800 RPM.
9. Allow engine to reach normal operating temperature. Watch the temperature gauge on the dash to ensure that the engine does not overheat.
10. Flush the engine for 10 minutes or until discharge water is clear.
11. Shut off the engine.

**⚠ CAUTION**

Engine overheating can cause engine damage. To avoid, observe the water temperature gauge and ensure that the engine is operating in the normal range.

**⚠ CAUTION**

Do not let water run more than 15 seconds with engine not operating or too much flushing water will collect in the muffler.

12. Within 15 seconds, disconnect the quick connect fitting and water hose from the flush socket on the engine by pressing the release button on the flush socket.
13. Attach to the next engine, if equipped, and repeat procedure.
14. Turn off the water source.
15. Remove the quick connect fitting from the water hose.
16. Replace the blue cap into the flush socket on the engine.
17. Open the seacock, if equipped, or unplug and reconnect the water inlet hose prior to operating the engine.

**NOTE:** *If the unit is to be stored in the water, the seacock should remain closed until time of usage. If unit is to be stored out of the water, open the seacock.*

## Tow Sports

1. **If flushing the engine with the boat in the water,** close the seacock or remove and plug the water inlet hose.

- a. **Models with Water V-Drive Transmissions:** Disconnect water inlet hose from the transmission fitting. Using appropriate connector, connect water hose to water source. Proceed to Step 3.

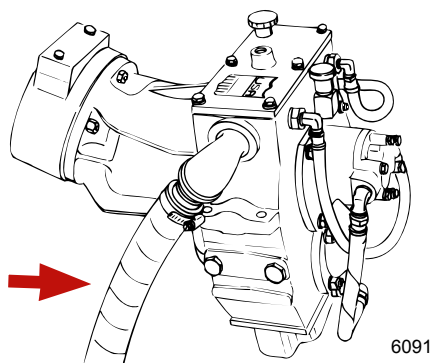

- b. **All other models:** Using appropriate connector, connect the flushing hose from the water source to the water inlet hose (upper hose) of the seawater pickup pump. Proceed to Step 3.

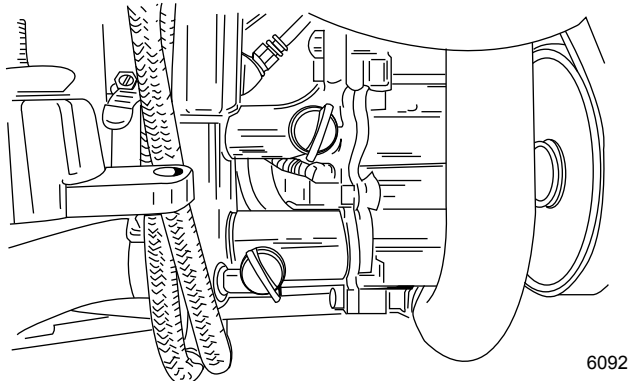

**⚠ WARNING**

Contact with moving drive components and the propeller can cause personal injury or death. To avoid possible injury, remove the propeller and ensure that no people or animals are in the area of the drive unit while flushing.

2. **If flushing the engine with the boat out of the water,** remove the propeller. Refer to boat manufacturers' instructions.
- a. **Models with Water V-Drive Transmissions:** Disconnect water inlet hose from transmission fitting. Using appropriate connector, connect the flushing hose. Proceed to Step 3.

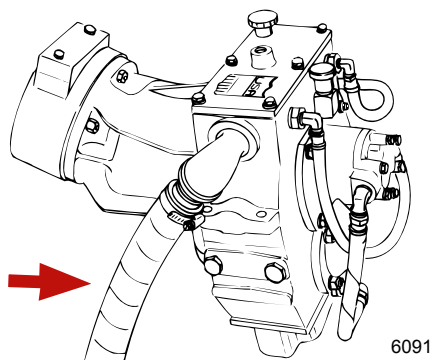

- b. **All other models:** Using appropriate connector, connect the flushing hose from the water to the water inlet hose (upper hose) of the seawater pickup pump. Proceed to Step 3.

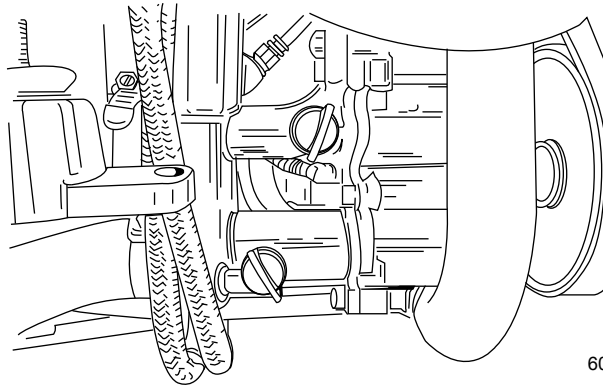

- 3. Open the water source.
- 4. Place remote control in neutral, idle speed position, and start engine. Operate engine at idle speed, in neutral, for about 10 minutes or until discharge water is clear.
- 5. Stop the engine.
- 6. Remove the flushing connector from the water inlet.
- 7. Reconnect the water inlet hose.
- 8. Tighten hose clamp securely.
- 9. Attach to the next engine, if equipped, and repeat procedure.
- 10. Turn off the water source.
- 11. Open the seacock, if equipped, or unplug and reconnect the water inlet hose prior to operating the engine.

**NOTE:** *If the unit is to be stored in the water, the seacock should remain closed until time of usage. If unit is to be stored out of the water, open the seacock.*

- 12. Replace the propeller if removed. Refer to the boat manufacturers' instructions.

## Battery

Refer to specific instructions and warnings accompanying your battery. If this information is not available, observe the following precautions when handling a battery.

**⚠ WARNING**

**Avoid serious injury from fire or explosion. Do not use jumper cables and a booster battery to start engine. Do not recharge a weak battery in the boat. Remove battery and recharge in a ventilated area away from fuel vapors, sparks or flames.**

**⚠ WARNING**

**Batteries contain acid which can cause severe burns. Avoid contact with skin, eyes and clothing. If electrolyte is spilled or splashed on any part of the body, immediately flush the exposed area with liberal amounts of water and obtain medical aid as soon as possible. Safety glasses and rubber gloves are recommended when handling batteries or filling with electrolyte.**



---

## Multiple EFI Engine Battery Precautions

**Alternators:** Alternators are designed to charge the battery that supplies electrical power to the engine that the alternator is mounted on. When batteries for 2 different engines are connected, one alternator will supply all of the charging current for both batteries. Normally, the other engine's alternator will not be required to supply any charging current.

**EFI Electronic Control Module (ECM):** The ECM requires a stable voltage source. During multiple engine operation, an onboard electrical device may cause a sudden drain of voltage at the engine's battery. The voltage may go below the ECM's minimum required voltage. Also, the alternator on the other engine may now start charging. This could cause a voltage spike in the engine's electrical system.

In either case, the ECM could shut off. When the voltage returns to the range that the ECM requires, the ECM will reset itself, and the engine will operate normally. The ECM shuts off and resets itself so quickly that the engine may only seem to have an ignition miss.

**Batteries:** Boats with multi-engine EFI power packages require each engine be connected to its own battery. This ensures that the engine's ECM has a stable voltage source.

**Battery Switches:** Battery switches should always be positioned so each engine is operating off of its own battery. Do not operate engines with switches in both or all position. In an emergency, another engine's battery can be used to start an engine with a dead battery.

**Battery Isolators:** Isolators can be used to charge an auxiliary battery used for powering accessories in the boat. They should not be used to charge the battery of another engine in the boat unless the type of isolator is specifically designed for this purpose.

**Generators:** The generators battery should be considered another engine's battery.

## Notes:

## Section 6 - Storage

### Table of Contents

Cold Weather or Extended Storage.....	76	Air Actuated Single Point Drain System.....	78
Preparing Power Package for Storage.....	76	Boat in the Water .....	78
Engine and Fuel System Preparation ....	77	Boat out of the Water .....	80
Draining the Seawater System.....	77	Three Point Manual Drain System.....	82
Drain System Identification.....	78	Boat in the Water .....	82
Air Actuated Single Point Drain System		Boat out of the Water .....	84
.....	78	Battery Storage.....	84
Three Point Manual Drain System .....	78	Power Package Recommissioning.....	84

## Cold Weather or Extended Storage

**IMPORTANT:** Mercury MerCruiser strongly recommends that this service should be performed by an authorized Mercury MerCruiser dealer. Damage caused by freezing temperatures IS NOT covered by the Mercury MerCruiser Limited Warranty.

### CAUTION

Seawater that is trapped in or remains in the cooling system seawater section during cold weather or winter storage can freeze resulting in cooling system or engine damage. Completely drain the seawater from the cooling system seawater section for winter storage or immediately after cold weather operation when the possibility of freezing temperatures exist.

**IMPORTANT:** Mercury MerCruiser requires that propylene glycol antifreeze, mixed to the manufacturers instructions, be used in the seawater section of the cooling system for freezing temperatures or extended storage. Make sure that the propylene glycol antifreeze contains a rust inhibitor and is recommended for use in marine engines. Be certain to follow the propylene glycol manufacturer's recommendations.

## Preparing Power Package for Storage

1. Fill the fuel tanks with fresh gasoline (that does not contain alcohol) and a sufficient amount of Quicksilver Gasoline Stabilizer for Marine Engines to treat the gasoline. Follow instructions on the container.
2. If the boat is to be placed in storage with fuel containing alcohol in fuel tanks (if fuel without alcohol is not available): Fuel tanks should be drained as low as possible and Mercury/Quicksilver Gasoline Stabilizer for Marine Engines added to any fuel remaining in the tank. Refer to **Fuel Requirements** for additional information.
3. Flush the cooling system. Refer to the **Maintenance** section.
4. Operate the engine sufficiently to bring it up to normal operating temperature and allow fuel with Mercury/Quicksilver Gasoline Stabilizer to circulate through the fuel system. Shut off the engine.
5. Change the oil and oil filter.
6. Prepare the engine and fuel system for storage. Refer to **Engine and Fuel System Preparation**.
7. Drain the engine seawater cooling system. Refer to **Draining the Seawater System**.

### CAUTION

If boat is in the water, seacock must remain closed until engine is to be re-started to prevent water from flowing back into cooling system and/or boat. If boat is not fitted with a seacock, water inlet hose must be left disconnected and plugged to prevent water from flowing back into cooling system and/or boat. As a precautionary measure, attach a tag to the ignition switch or steering wheel of the boat with the warning: Open seacock or reconnect water inlet hose before starting engine.

8. For additional assurance against freezing and rust, after draining, fill the seawater cooling system with propylene glycol mixed to the manufacturer's recommendation to protect engine to the lowest temperature to which it will be exposed during freezing temperatures or extended storage.
9. Store the battery according to the manufacturer's instructions.

## ENGINE AND FUEL SYSTEM PREPARATION



**⚠ WARNING**

Avoid serious injury or death from a gasoline fire or explosion; gasoline is extremely flammable and highly explosive under certain conditions. When servicing the fuel system components ensure that the engine is cool, the ignition switch is in the off position, and that the lanyard stop switch, if equipped, is in the off position. Do not smoke or allow spark or open flame in the area. Wipe up any spilled fuel immediately. Ensure that no fuel leaks exist before closing the engine hatch.

**⚠ WARNING**

Fuel vapors can be present in the engine compartment. Avoid injury or power package damage caused by fuel vapors or explosion. Always ventilate the engine compartment prior to servicing the power package.

1. In a 23 liter (6 U.S.gal.) remote fuel tank mix:
  - a. 19 liter (5 U.S. gal) regular unleaded 87 octain (90 RON) gasoline
  - b. 1.89 liter (2 U.S. qts.) Premium Plus 2-Cycle TC-W3 Outboard Oil
  - c. 150 ml (5 ounces) Fuel System Treatment and Stabilizer or 30 ml (1 ounce) Fuel System Treatment and Stabilizer Concentrate

Tube Ref No.	Description	Where Used	Part No.
 115	Premium Plus 2-cycle TC-W3 Outboard Oil	Fuel system	92-802824A1
 124	Fuel System Treatment & Stabilizer	Fuel system	802875A1

2. Allow the engine to cool down.

**IMPORTANT: Immediately wipe up any fuel spills or sprays.**

3. Close the fuel shut off valve, if equipped. Disconnect and plug the fuel inlet fitting if not equipped with a fuel shut off valve.
4. Connect the remote fuel tank (with the fogging mixture) to the fuel inlet fitting.

**IMPORTANT: Supply cooling water to the engine.**

5. Start and operate the engine at 1300 rpm for 5 minutes.
6. After specified operating time is complete, slowly return throttle to idle rpm and shut engine off.

**IMPORTANT: Ensure that some fogging mixture remains in the engine. Do not allow the engines fuel system to become completely dry.**

7. Replace the water separating fuel filter element. Refer to Section 5 for proper procedure.

## Draining the Seawater System

**⚠ CAUTION**

Excess water in the bilge can damage the engine or cause the boat to sink. Ensure that the boat is out of the water, the seacock is closed (if equipped) or the seawater inlet hose is disconnected and plugged on both ends, and the bilge pump is operating before beginning the draining procedure.

**⚠ CAUTION**

Excess water in the bilge can damage the engine or cause the boat to sink. When the drain system is open excess water can enter the bilge. Do not operate the engine with the drain system open.

**IMPORTANT:** Only drain the seawater section of the closed cooling system.

**IMPORTANT:** The boat must be as level as possible to ensure complete draining of the cooling system.

Your power package is equipped with a drain system. Refer to **Drain System Identification** to determine which instructions apply to your power package.

**IMPORTANT:** The engine must not be operating at any point during the draining procedure.

**Drain System Identification**

**AIR ACTUATED SINGLE POINT DRAIN SYSTEM**

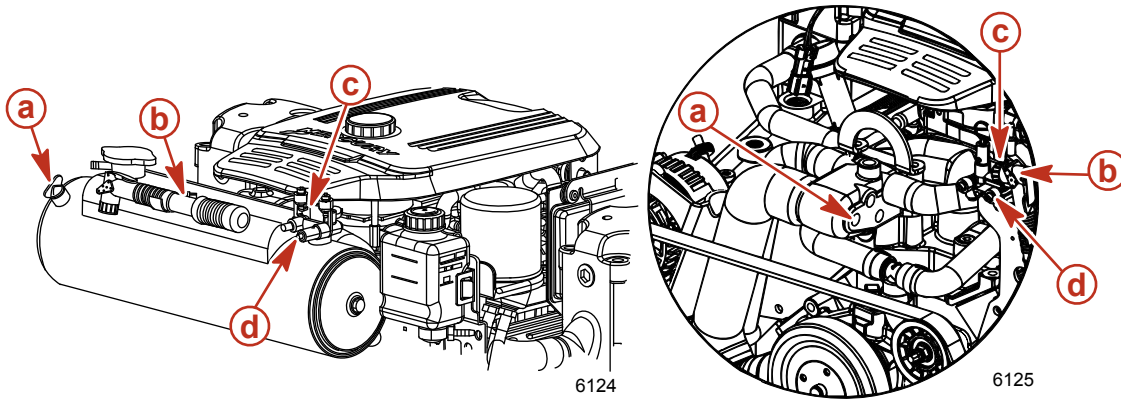

**Closed Cooled Models**

- a** - Blue drain plug location
- b** - Blue air pump

**Seawater Cooled Models**

- c** - Air manifold
- d** - Green indicators

**THREE POINT MANUAL DRAIN SYSTEM**



- a** - Blue drain plug

**Air Actuated Single Point Drain System**

**BOAT IN THE WATER**

**NOTE:** This procedure is written for the air pump that is attached to the engine. However, any air source can be used.

1. Close the seacock (if equipped) or remove and plug the water inlet hose.

2. Remove the air pump from the engine.
3. Ensure that the lever on top of the pump is flush with the handle (horizontal).
4. Install the air pump on the actuator fitting.
5. Pull lever on air pump (vertical) to lock pump on the fitting.

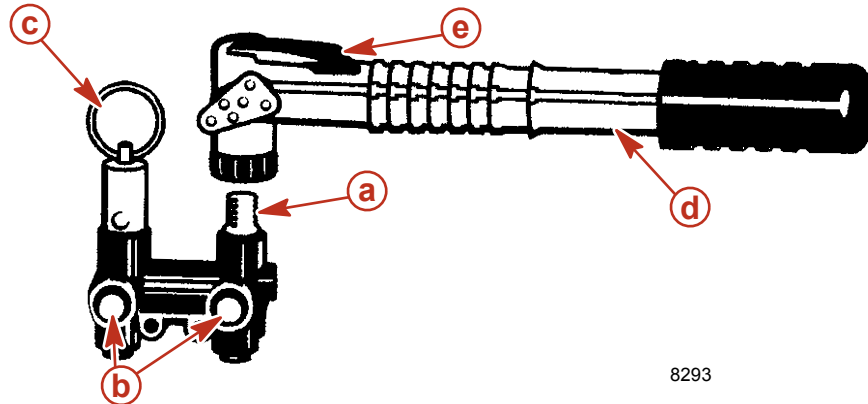

8293

- |                                 |                            |
|---------------------------------|----------------------------|
| <b>a</b> - Actuator fitting     | <b>d</b> - Air pump        |
| <b>b</b> - Green indicators     | <b>e</b> - Lever (locking) |
| <b>c</b> - Manual release valve |                            |

6. Pump air into the system until both green indicators extend and water drains from both sides of the engine. The port side will begin draining before the starboard side.
7. Immediately remove the blue drain plug from the side of the thermostat housing or the heat exchanger. This must be removed within 30 seconds to properly vent the cooling system.

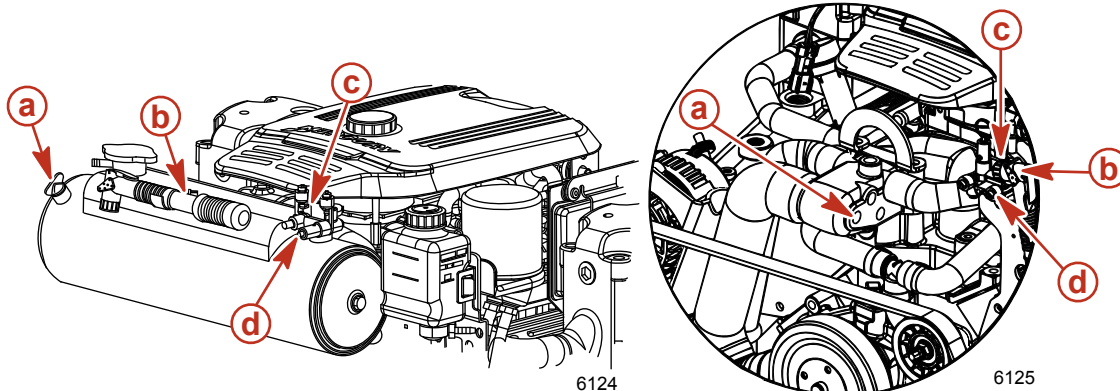

#### Closed Cooled Models

- |                                     |
|-------------------------------------|
| <b>a</b> - Blue drain plug location |
| <b>b</b> - Blue air pump            |

#### Seawater Cooled Models

- |                             |
|-----------------------------|
| <b>c</b> - Air manifold     |
| <b>d</b> - Green indicators |

- Verify that water is draining from each opening. If not, use the **Three Point Manual Drain System** instructions.

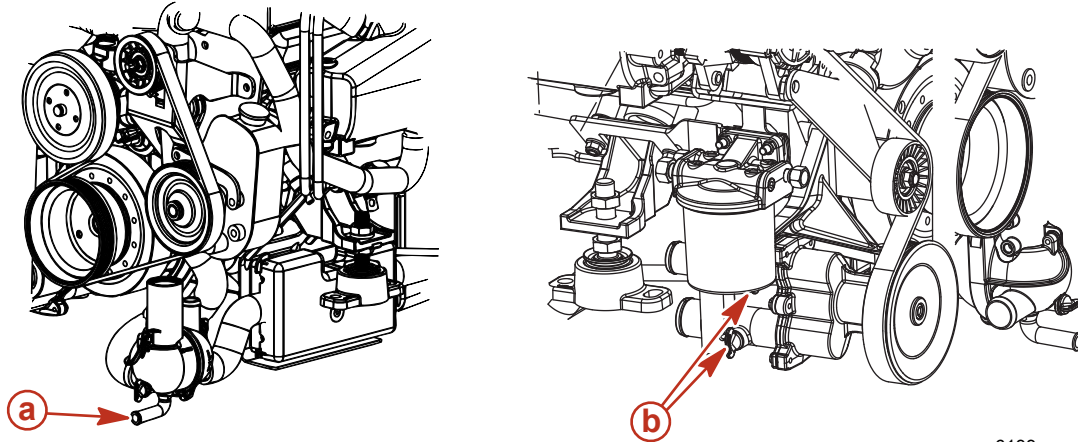

**a** - Port side drain location

**b** - Starboard side drain location

- Allow the system to drain for a minimum of five minutes. Pump air as necessary to keep the green indicators extended.
- Crank the engine over slightly with the starter motor to purge any water trapped in the seawater pump. Do not allow engine to start.
- Reinstall the blue drain plug in the thermostat housing or heat exchanger.
- Remove the air pump from the air manifold and return it to the mounting bracket.
- Mercury MerCruiser recommends leaving the drain system open while transporting the boat or while performing other maintenance. This helps ensure that all water is drained.
- Before launching the boat, pull up on the manual release valve. Verify that the green indicators are no longer extended.

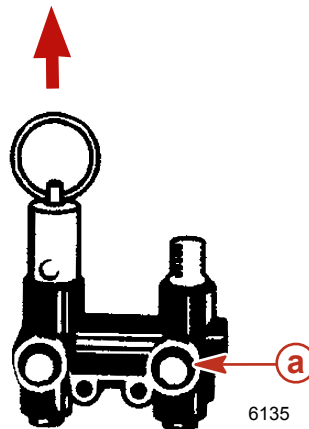

**a** - Green indicators

- Open the seacock, if equipped, or unplug and reconnect the water inlet hose prior to operating the engine.

### BOAT OUT OF THE WATER

**NOTE:** This procedure is written for the air pump that is attached to the engine. However, any air source can be used.

- Place the boat on a level surface to ensure complete draining of system.
- Remove the air pump from the engine.



3. Ensure that the lever on top of the pump is flush with the handle (horizontal).
4. Install the air pump on the actuator fitting.
5. Pull lever on air pump (vertical) to lock pump on the fitting.

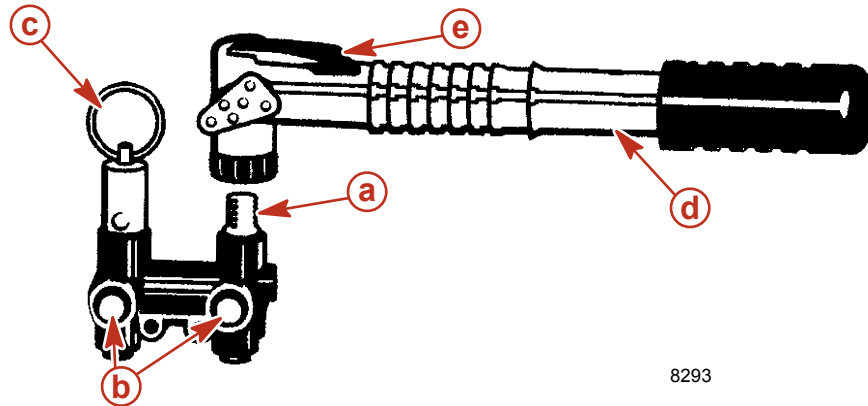

8293

- a** - Actuator fitting
- b** - Green indicators
- c** - Manual release valve
- d** - Air pump
- e** - Lever (locking)

6. Pump air into the system until both green indicators extend and water drains from both sides of the engine. The port side will begin draining before the starboard side.

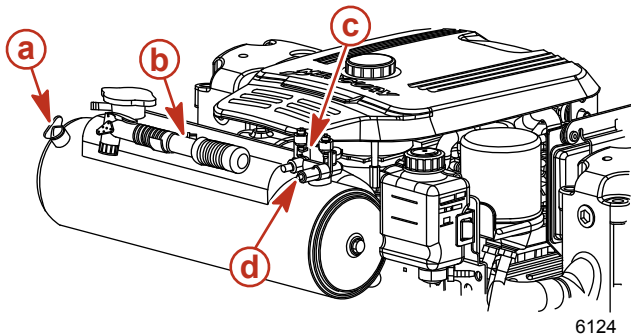

6124

#### Closed Cooled Models

- a** - Blue drain plug location
- b** - Blue air pump

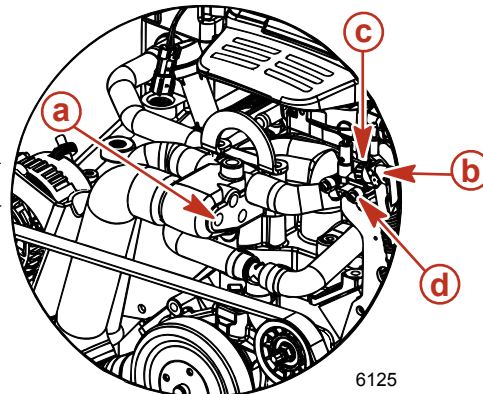

6125

#### Seawater Cooled Models

- c** - Air manifold
- d** - Green indicators

7. Verify that water is draining from each opening. If not, use the **Three Point Manual Drain System** instructions.

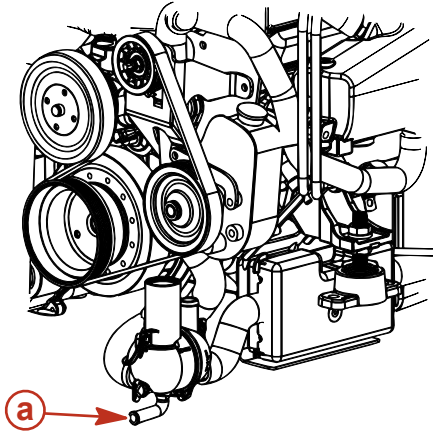

**a** - Port side drain location

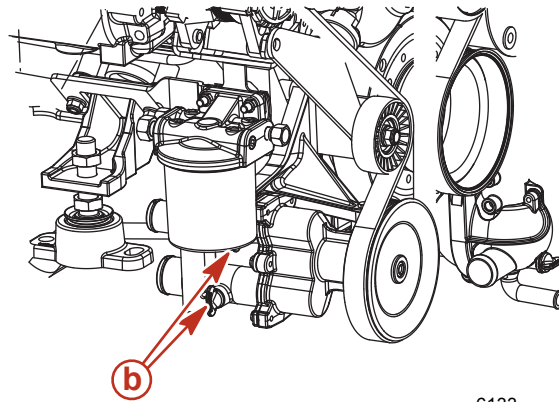

**b** - Starboard side drain location

6133

8. Allow the system to drain for a minimum of five minutes. Pump air as necessary to keep the green indicators extended.
9. Crank the engine over slightly with starter motor to purge any water trapped in the seawater pump. Do not allow engine to start.
10. Remove the air pump from the air manifold and return it to the mounting bracket.
11. Mercury MerCruiser recommends leaving the drain system open while transporting the boat or while performing other maintenance. This helps ensure that all water is drained.
12. Before launching the boat, pull up on the manual release valve. Verify that the green indicators are no longer extended.

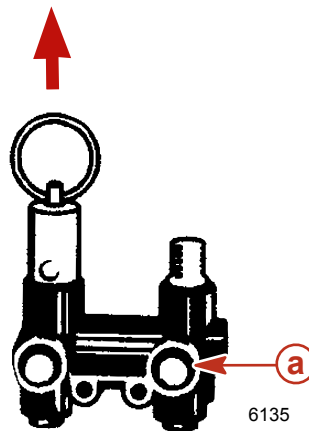

**a** - Green indicators

6135

## Three Point Manual Drain System

### BOAT IN THE WATER

**NOTE:** Use this procedure if your engine is not equipped with an air actuated single point drain system or if the air actuated single point drain system fails.

1. Close the seacock (if equipped) or remove and plug the water inlet hose.

- Remove the blue drain plug from the distribution housing (lower front, port side).

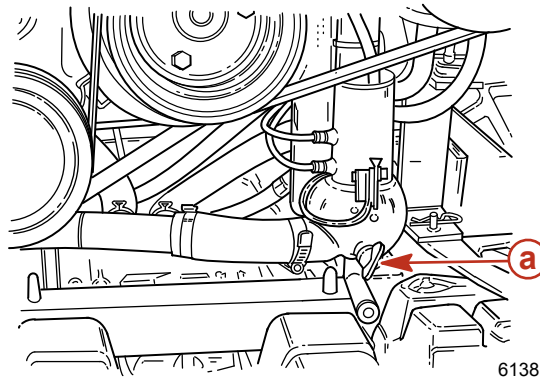

**a** - Blue drain plug

- To properly vent the cooling system, remove the blue drain plug from the side of the thermostat housing within 30 seconds.

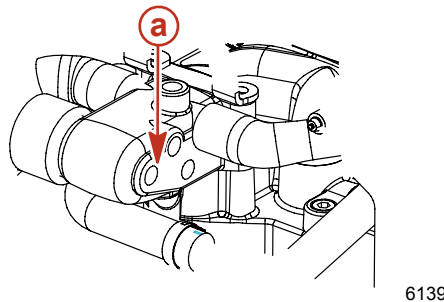

**a** - Blue drain plug location

- Remove the two blue drain plugs from the seawater pickup pump (front, starboard side).

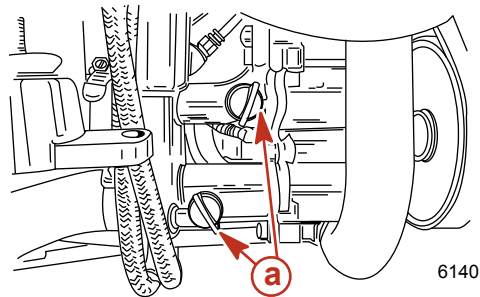

**a** - Blue drain plugs

- Verify that water is draining from each opening.
- Allow the system to drain for a minimum of five minutes. Mercury MerCruiser recommends leaving the drain system open while transporting the boat or while performing other maintenance to ensure that all water is drained.
- Crank the engine over slightly with starter motor to purge any water trapped in the seawater pickup pump. Do not allow the engine to start.
- Prior to launching the boat or starting the engine, close the drain system by installing the four blue drain plugs.
- Open the seacock, if equipped, or unplug and reconnect the water inlet hose prior to operating the engine.

## BOAT OUT OF THE WATER

**NOTE:** Use this procedure if your engine is not equipped with an air actuated single point drain system or if the single point drain system fails.

1. Place the boat on a level surface to ensure complete draining of the system.
2. Remove three blue drain plugs: one from the distribution housing (lower front, port side) and two from the seawater pickup pump (front, starboard side).

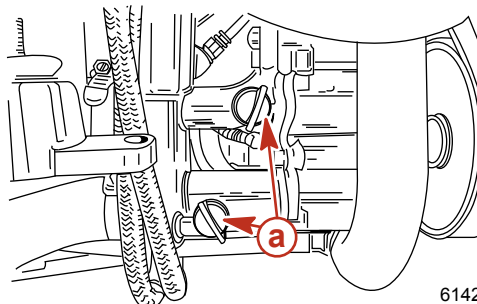
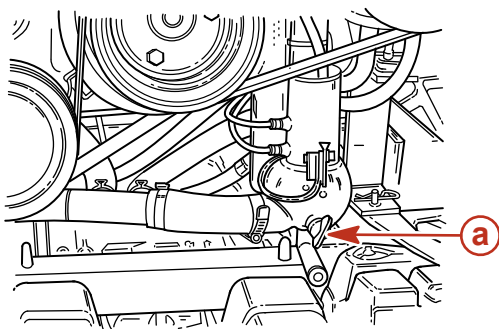

6142

**a** - Blue drain plug

3. Verify that water is draining from each opening.
4. Allow the system to drain for a minimum of five minutes. Mercury MerCruiser recommends leaving the drain system open while transporting the boat or while performing other maintenance to ensure that all water is drained.
5. Crank the engine over slightly with starter motor to purge any water trapped in the seawater pickup pump. Do not allow the engine to start.
6. Prior to launching the boat or starting the engine, close the drain system by installing the three blue drain plugs.

## Battery Storage

Whenever the battery will be stored for an extended period of time, be sure the cells are full of water and the battery is fully charged and in good operating condition. It should be clean and free of leaks. Follow the battery manufacturer's instructions for storage.

## Power Package Recommissioning

1. Ensure that all cooling system hoses are connected properly and hose clamps are tight.

### ⚠ CAUTION

Avoid electrical system damage. When installing the battery, be sure to connect the negative (-) battery cable to the negative (-) battery terminal and the positive (+) battery cable to the positive (+) battery terminal.

2. Install a fully charged battery. Clean the battery cable clamps and terminals and reconnect cables. Tighten each cable clamp securely when connecting.
3. Coat the terminal connections with a battery terminal anti-corrosion agent.
4. Perform all the checks in the before starting column of the **Operation Chart**.

### ⚠ CAUTION

Overheating from insufficient cooling water will cause engine and drive system damage. Ensure that there is sufficient water always available at water inlet holes during operation.

5. Start the engine and closely observe instrumentation to ensure that all systems are functioning correctly.
6. Carefully inspect the engine for fuel, oil, fluid, water and exhaust leaks.
7. Inspect the steering system, shift and throttle control for proper operation.

Notes:

# Section 7 - Troubleshooting

## Table of Contents

---

Diagnosing EFI Problems.....	88	Excessive Engine Temperature.....	89
Diagnosing DTS Problems.....	88	Insufficient Engine Temperature.....	90
Engine Guardian System.....	88	Low Engine Oil Pressure.....	90
Starter Motor Will Not Crank Engine, Or Cranks		Battery Will Not Come Up On Charge.....	90
Slow.....	88	Remote Control Operates Hard, Binds, Has	
Engine Will Not Start Or Is Hard To Start.....	88	Excessive Free-play Or Makes Unusual Sounds	
Engine Runs Rough, Misses And/Or Backfires		.....	90
.....	89	Steering Wheel Turns Hard Or Jerky.....	90
Poor Performance.....	89		

---



## Diagnosing EFI Problems

Your authorized Mercury MerCruiser dealer has the proper service tools for diagnosing problems on Electronic Fuel Injection (EFI) Systems. The Electronic Control Module (ECM) on these engines has the ability to detect some problems with the system when they occur, and store a Trouble Code in the ECM's memory. This code can then be read later by a service technician using a special diagnostic tool.

## Diagnosing DTS Problems

Your authorized Mercury MerCruiser dealer has the proper service tools for diagnosing problems on Digital Throttle and Shift (DTS) Systems. The Electronic Control Module (ECM)/Propulsion Control Module (PCM) on these engines has the ability to detect some problems with the system when they occur, and store a Trouble Code in the ECM/PCM's memory. This code can then be read later by a service technician using a special diagnostic tool.

## Engine Guardian System

The Engine Guardian System monitors the critical sensors on the engine for any early indications of problems. The system will respond to a problem by emitting a continuous beep and/or reducing engine power in order to provide engine protection.

If Guardian System has been activated, reduce throttle speed. The horn will turn off when throttle speed is within the allowable limit. Consult an authorized Mercury MerCruiser dealer for assistance.

## Starter Motor Will Not Crank Engine, Or Cranks Slow

Possible Cause	Remedy
Battery switch turned off.	Turn the switch on.
Remote control not in neutral position.	Position the control lever in neutral.
Open circuit breaker or blown fuse.	Check and reset the circuit breaker or replace fuse.
Loose or dirty electrical connections or damaged wiring.	Check all electrical connections and wires (especially battery cables). Clean and tighten all faulty connections.
Bad battery or low battery voltage.	Test the battery and charge if necessary; replace if bad.
Lanyard stop switch activated.	Check the lanyard stop switch.

## Engine Will Not Start Or Is Hard To Start

Possible Cause	Remedy
Lanyard stop switch activated.	Check the lanyard stop switch.
Improper starting procedure.	Read the starting procedure.
Insufficient fuel supply.	Fill fuel tank or open valve.
Faulty ignition system component.	Service the ignition system.
Clogged fuel filter.	Replace fuel filter.
Stale or contaminated fuel.	Drain fuel tank. Fill with fresh fuel.
Fuel line or tank vent line kinked or clogged.	Replace kinked lines or blow out lines with compressed air to remove obstruction.
Faulty wire connections.	Check wire connections.



Possible Cause	Remedy
EFI system fault.	Have EFI System checked by an authorized Mercury MerCruiser dealer.

## Engine Runs Rough, Misses And/Or Backfires

Possible Cause	Remedy
Clogged fuel filter.	Replace filter.
Stale or contaminated fuel.	If contaminated, drain tank. Fill with fresh fuel.
Kinked or clogged fuel line or fuel tank vent line.	Replace kinked lines or blow out lines with compressed air to remove obstruction.
Flame Arrestor dirty.	Clean Flame Arrestor.
Faulty ignition system component.	Service ignition system.
Idle speed too low.	Have EFI system checked by an authorized Mercury MerCruiser dealer.
EFI System fault.	Have EFI System checked by an authorized Mercury MerCruiser dealer.

## Poor Performance

Possible Cause	Remedy
Throttle not fully open.	Inspect the throttle cable and linkages for proper operation.
Damaged or improper propeller.	Replace the propeller.
Excessive bilge water.	Drain and check for cause of entry.
Boat overloaded or load improperly distributed.	Reduce load or redistribute load more evenly.
Flame arrestor dirty.	Clean the flame arrestor.
Boat bottom fouled or damaged.	Clean or repair as necessary.
Ignition problem.	See <b>Engine Runs Rough, Misses or Backfires</b> .
Engine overheating.	See <b>Excessive Engine Temperature</b> .
EFI System fault	Have EFI System checked by an authorized Mercury MerCruiser dealer.

## Excessive Engine Temperature

Possible Cause	Remedy
Water inlet or seacock closed.	Open.
Drive belt loose or in poor condition.	Replace or adjust belt.
Seawater pickups or sea strainer obstructed.	Remove obstruction.
Faulty thermostat.	Replace.
Coolant level (if equipped) low in closed cooling section.	Check for cause of low coolant level and repair. Fill system with proper coolant solution.
Heat Exchanger or Fluid Cooler plugged with foreign material	Clean Heat Exchanger, Engine Oil Cooler, and Transmission Oil Cooler (if equipped).
Loss of pressure in closed cooling section.	Check for leaks. Clean, inspect and test pressure cap.
Faulty seawater pickup pump.	Repair.
Seawater discharge restricted or plugged.	Clean exhaust elbows.

## Insufficient Engine Temperature

Possible Cause	Remedy
Faulty thermostat.	Replace.

## Low Engine Oil Pressure

Possible Cause	Remedy
Insufficient oil in crankcase.	Check and add oil.
Excessive oil in crankcase (causing it to become aerated).	Check and remove required amount of oil. Check for cause of excessive oil (improper filling).
Diluted or improper viscosity oil.	Change oil and oil filter, using correct grade and viscosity oil. Determine cause for dilution (excessive idling).

## Battery Will Not Come Up On Charge

Possible Cause	Remedy
Excessive current draw from battery.	Turn off non-essential accessories.
Alternator drive belt loose or in poor condition.	Replace and/or adjust.
Unacceptable battery condition.	Test battery, replace if necessary.
Loose or dirty electrical connections or damaged wiring.	Check all associated electrical connections and wires (especially battery cables). Clean and tighten faulty connections. Repair or replace damaged wiring.
Faulty alternator	Test alternator output, replace if necessary.

## Remote Control Operates Hard, Binds, Has Excessive Free-play Or Makes Unusual Sounds

Possible Cause	Remedy
Insufficient lubrication on shift and throttle linkage fasteners.	Lubricate.
Obstruction in shift or throttle linkages.	Remove obstruction.
Loose or missing shift and throttle linkages.	Check all throttle linkages. If any are loose or missing, see authorized Mercury MerCruiser dealer immediately.
Shift or throttle cable kinked.	Straighten cable or have authorized Mercury MerCruiser dealer replace cable if damaged beyond repair.

## Steering Wheel Turns Hard Or Jerky

Possible Cause	Remedy
Low power steering pump fluid level.	Check for leak. Refill system with fluid.
Drive belt loose or in poor condition.	Replace and/or adjust.
Insufficient lubrication on steering components.	Lubricate.
Loose or missing steering fasteners or parts.	Check all parts and fasteners if any are loose or missing, see authorized Mercury MerCruiser dealer immediately.
Contaminated power steering fluid.	See authorized Mercury MerCruiser dealer.

## Section 8 - Customer Assistance Information

### Table of Contents

---

Owner Service Assistance.....	92	Parts And Accessories Inquiries .....	93
Local Repair Service .....	92	Resolving A Problem .....	93
Service Away From Home .....	92	Mercury Marine Service Offices .....	93
Stolen Power Package .....	92	Ordering Literature.....	94
Attention Required After Submersion .....	92	United States and Canada .....	94
Replacement Service Parts .....	92	Outside The United States and Canada .....	94

---

## Owner Service Assistance

### Local Repair Service

Always return your Mercury MerCruiser powered boat to your authorized dealer should the need for service arise. Only he has the factory trained mechanics, knowledge, special tools and equipment and the genuine Quicksilver parts and accessories<sup>1</sup> to properly service your engine should the need occur. He knows your engine best.

### Service Away From Home

If you are away from your local dealer and the need arises for service, contact the nearest authorized dealer. Refer to the Yellow Pages of the telephone directory. If, for any reason, you cannot obtain service, contact the nearest Regional Service Center. Outside the United States and Canada, contact the nearest Marine Power International Service Center.

### Stolen Power Package

If your power package is stolen, immediately advise the local authorities and Mercury Marine of the model and serial numbers and to whom the recovery is to be reported. This information is maintained in a database at Mercury Marine to aid authorities and dealers in recovery of stolen power packages.

### Attention Required After Submersion

1. Before recovery, contact an authorized Mercury MerCruiser dealer.
2. After recovery, immediate service by an authorized Mercury MerCruiser dealer is required to reduce the possibility of serious engine damage.

### Replacement Service Parts

#### **WARNING**

**Serious injury or death may occur to the boating public if boat systems are incorrectly designed, manufactured, or installed. To minimize risks of fire or explosion, electrical, ignition and fuel system components on Mercury Marine power products are designed and manufactured to comply with numerous international directives, federal regulations, voluntary standards, and product installation instructions.**

**Use or installation of replacement electrical, ignition or fuel system components, which do not comply with these directives, regulations, standards and instructions could result in a fire or explosion hazard and should be avoided.**

Marine engines are expected to operate at or near full throttle for most of their life. They are also expected to operate in both fresh and saltwater environments. These conditions require numerous special parts. Care should be exercised when replacing marine engine parts as specifications are quite different from those of the standard automotive engine.

For example, one of the most important, and probably the least suspected special replacement part, is the cylinder head gasket. Since saltwater is highly corrosive, the steel-type automotive head gasket cannot be used. A marine engine head gasket uses special materials to resist corrosive action.

Since marine engines must be capable of running at or near maximum RPM much of the time, special valve springs, valve lifters, pistons, bearings, camshafts and other heavy duty moving parts are required for long life and peak performance.

These are but a few of the many special modifications that are required in Mercury MerCruiser marine engines to provide long life and dependable performance.

1. Quicksilver parts and accessories are engineered and built by Mercury Marine, specifically for Mercury MerCruiser sterndrives and inboards.

## PARTS AND ACCESSORIES INQUIRIES

All inquiries concerning Quicksilver replacement parts and accessories should be directed to your local authorized dealer. The dealer has the necessary information to order parts and accessories for you should he not have them in stock. Only authorized dealers can purchase genuine Quicksilver parts and accessories from the factory. Mercury Marine does not sell to unauthorized dealers or retail customers. When inquiring on parts and accessories, the dealer requires the **engine model** and **serial numbers** to order the correct parts.

## Resolving A Problem

Satisfaction with your Mercury MerCruiser product is very important to your dealer and to us. If you ever have a problem, question or concern about your power package, contact your dealer or any authorized Mercury MerCruiser dealership. If additional assistance is required, take these steps:

1. Talk with the dealership's sales manager or service manager. If this has already been done, then contact the owner of the dealership.
2. Should you have a question, concern or problem that cannot be resolved by your dealership, please contact Mercury Marine Service Office for assistance. Mercury Marine will work with you and your dealership to resolve all problems.

The following information will be needed by the service office:

- Your name and address
- Daytime telephone number
- Model and serial numbers for your power package
- The name and address of your dealership
- Nature of problem

Mercury Marine Service Offices are listed on the next page.

## Mercury Marine Service Offices

For assistance, call, fax or write. Please include your daytime telephone number with mail and fax correspondence.

Telephone	Fax	Mail
(405) 743 6566	(405) 743 6570	Mercury MerCruiser 3003 N. Perkins Rd. Stillwater, OK 74075
(905) 567 MERC (6372)	(905) 567 8515	Mercury Marine Ltd. 2395 Meadowpine Blvd. Mississauga, Ontario L5N 7W6 Canada
(61) (3) 9791 5822	(61) (3) 9793 5880	Mercury Marine Australia 132-140 Frankston Road Dandenong, Victoria 3164 Australia
(32) (87) 32 32 11	(32) (87) 31 19 65	Marine Power - Europe, Inc. Parc Industriel de Petit-Rechain B-4800 Verviers, Belgium

## Customer Assistance Information

---

Telephone	Fax	Mail
(954) 744 3500	(954) 744 3535	Mercury Marine - Latin America & Caribbean 11650 Interchange Circle North, Miramar, FL 33025 U.S.A.
(81) 53 423 2500	(81) 53 423 2510	Mercury Marine - Japan 283-1 Anshin-cho Hamamatsu, Shizuoka 435-0005 Japan
(65) 6546 6160	(65) 6546 7789	Mercury Marine Singapore 72 Loyang Way , 508762 Singapore

## Ordering Literature

Before ordering literature, please have the following information about your power package available:

- Model
- Serial Number
- Horsepower
- Year built

## United States and Canada

For information on additional literature that is available for your particular Mercury MerCruiser power package and how to order that literature contact your nearest dealer or contact

Mercury Marine Publications  
P.O. Box 1939  
Fond du Lac, WI 54936-1939  
(920) 929-5110  
Fax (920) 929-4894

## Outside The United States and Canada

Contact your nearest dealer or Marine Power Service Center for information on additional literature that is available for your particular Mercury MerCruiser power package and how to order that literature.

Please return with payment to:  
Mercury Marine  
Attn: Publications Department  
W6250 West Pioneer Road  
P.O. Box 1939  
Fond du Lac, WI 54936-1939

### **Ship To: (Please Print Or Type - This Is Your Shipping Label)**

Name

Address

City State ZIP