

Gasoline Engines - Inboard Models

Identification Record

Please record the following information:

1.	Engine Model and Horsepower	Engine Serial Number	
2.	Transom Assembly Serial Number (Sterndrive)	Gear Ratio	Sterndrive Unit Serial Number
3.	Transmission Model (Inboard)	Gear Ratio	Transmission Serial Number
4.	Propeller Number	Pitch	Diameter
5.	Hull Identification Number (HIN)	Purchase Date	
6.	Boat Manufacturer	Boat Model	Length
7.	Exhaust Gas Emissions Certificate Number (Europe Only)		

Serial Numbers

The serial numbers are the manufacturer's keys to numerous engineering details which apply to your MerCruiser® power package. When contacting your Authorized MerCruiser Dealer about service, **always specify model and serial numbers.**

The description and specifications contained herein were in effect at the time this guide was approved for printing. Mercury Marine, whose policy is one of continuous improvement, reserves the right to discontinue models at any time, or to change specifications or designs, without notice and without incurring obligation.

Mercury Marine, Fond du Lac, Wisconsin, U.S.A.

Printed in U.S.A.

©1999, Mercury Marine

The following are registered trademarks of Brunswick Corporation: AutoBlend, Jet-Prop, Mariner, Merc, MerCathode, MerCruiser, Mercury, Mercury Marine, Quicksilver, RideGuide, and Thruster.

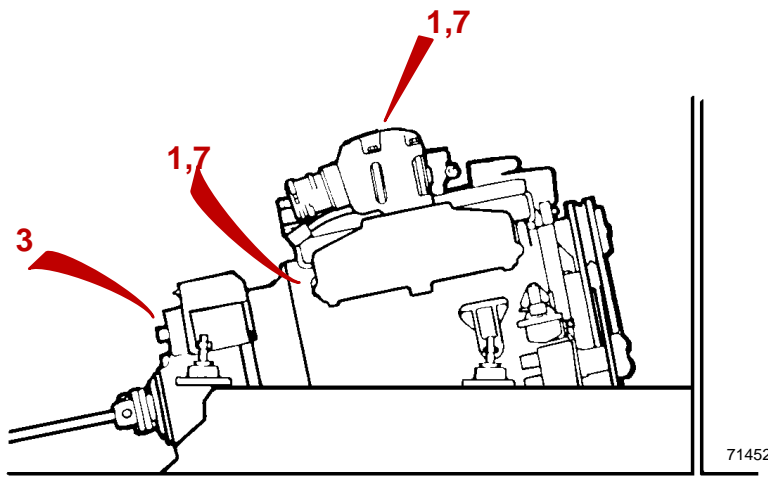

Welcome!

You have selected one of the finest marine power packages available. It incorporates numerous design features to assure operating ease and durability.

With proper care and maintenance, you will thoroughly enjoy using this product for many boating seasons. To ensure maximum performance and carefree use, we ask that you thoroughly read this manual.

The Operation, Maintenance and Warranty Manual contains specific instructions for using and maintaining your product. We suggest that this manual remain with the product for ready reference whenever you are on the water.

Thank you for purchasing one of our MerCruiser products. We sincerely hope your boating will be pleasant!

Consumer Affairs Department

Warranty Message

The product you have purchased comes with a **limited warranty** from Mercury Marine; the terms of the warranty are set forth in the *Warranty* Sections of this manual. The warranty statement contains a description of what is covered, what is not covered, the duration of coverage, how to best obtain warranty coverage, **important disclaimers and limitations of damages**, and other related information. Please review this important information.

IMPORTANT: This manual contains basic Operation, Maintenance and Warranty information for your MerCruiser power package. If you desire to perform some of the maintenance items on your own, you should obtain a copy of the Service Manual for your particular power package. Information for obtaining this manual is located at the back of this manual.

Table of Contents

	Page
Warranty Information	4
Owner Warranty Registration	4
International Owner Registration	5
MerCruiser Limited Warranty - Gasoline Engines	6
MerCruiser International Warranty - Gasoline Engines	7
3 Year Limited Warranty Against Corrosion Failure	8
Read This Manual Thoroughly	11
General Information	13
Lanyard Stop Switch	13
Exhaust Emissions	15
Safe Boating Suggestions	16
Protecting People In The Water	17
High-Speed And High-Performance Boat Operation	17
Conditions Affecting Operation	18
Important Information	21
Operation And Maintenance	21
Freezing Temperature Operation	21
Drain Plug and Bilge Pump	21
Attention Required After Submersion	21
Launching And Boat Operation Care	22
Stolen Power Package	22
Replacement Service Parts	22
Do-It-Yourself Maintenance Suggestions	23
Multiple EFI Engine Battery Precautions	23
Diagnosing EFI Problems	24
Water Separating Fuel Filter	24
20-Hour Break-In Period	25
After Break-In Period	25
End of First Season Checkup	25
Operation	26
Instrumentation	26
Audio Warning System	27
Electrical System Overload Protection	29
Remote Controls	31
Starting, Shifting And Stopping	33
Operation Chart	34
Specifications	35
Crankcase Oil	36
Engine Specifications	37

Maintenance	39
Maintenance Aids	39
Maintenance Chart	39
Checking Fluid Levels	43
Changing Fluids	45
Changing Water Separating Fuel Filter	47
Lubrication	49
Flushing Cooling System	50
Serpentine Drive Belt	51
Emissions (Europe Only)	53
Battery	54
Bottom Of Boat	55
Inspection And Maintenance	55
Cold Weather or Extended Storage	57
Power Package Lay Up	57
Draining Instructions	61
Battery Winter Storage	66
Do-It-Yourself Maintenance	66
Power Package Recommissioning	66
Troubleshooting	67
Owner Service Assistance	71

Warranty Information

Owner Warranty Registration

UNITED STATES AND CANADA ONLY

- It is important that your selling dealer fills out the Warranty Registration Card completely and mails it to the factory immediately upon sale of the new product.
- It identifies name and address of the original purchaser, product model and serial number(s), date of sale, type of use and selling dealer's code, name and address. The dealer also certifies that you are the original purchaser and user of the product.
- Upon receipt of the Warranty Registration Card at the factory, you will be issued a plastic Owner Warranty Registration Card which is your only valid registration identification. It must be presented to the servicing dealer should warranty service be required. Warranty claims will not be accepted without presentation of this card.
- A temporary Owner Warranty Registration Card will be presented to you when you purchase the product. It is valid only for 30 days from date of sale while your plastic Owner Warranty Registration Card is being processed. Should your product need service during this period, present the temporary registration card to the dealer. He will attach it to your warranty claim form.
- Because of your selling dealer's continuing personal interest in your satisfaction, the product should be returned to him for warranty service.
- If your plastic card is not received within 30 days from date of new product sale, please contact your selling dealer.
- The product warranty is not effective until the product is registered at the factory.
- NOTICE: Registration lists must be maintained by factory and dealer on marine products sold in the United States, should notification under the Federal Boat Safety Act be required.

International Owner Registration

OUTSIDE THE UNITED STATES AND CANADA

- It is important that your selling dealer fills out the Warranty Registration Card completely and mails it to the distributor or Marine Power Service Center responsible for administering the warranty registration/claim program for your area.
- The Warranty Registration Card identifies your name and address, product model and serial number(s), date of sale, type of use and the selling distributor's/dealer's code number, name and address. The distributor/dealer also certifies that you are the original purchaser and user of the product.
- A copy of the Warranty Registration Card, designated as the "Purchaser's Copy", MUST be given to you immediately after the card has been completely filled out by the selling distributor/dealer. This card represents your factory registration identification, and should be retained by you for future use when required. Should you ever require warranty service on this product, your dealer may ask you for the Warranty Registration Card to verify date of purchase and to use the information on the card to prepare the warranty claim form (s).
- In some countries, the Marine Power Service Center will issue you a permanent (plastic) Warranty Registration Card within 30 days after receiving the "Factory Copy" of the Warranty Registration Card from your distributor/dealer. If you receive a plastic Warranty Registration Card, you may discard the "Purchaser's Copy" that you received from the distributor/dealer when you purchased the product. Ask your distributor/dealer if this plastic card program applies to you.
- For further information concerning the Warranty Registration Card and its relationship to Warranty Claim processing, refer to the "International Warranty". Refer to "Table of Contents".

IMPORTANT: Registration lists must be maintained by the factory and dealer in some countries by law. It is our desire to have ALL products registered at the factory should it ever be necessary to contact you. Make sure your dealer/distributor fills out the warranty registration card immediately and sends the factory copy to the Marine Power International Service Center for your area.

Warranty Policies

MerCruiser Limited Warranty - Gasoline Engines

UNITED STATES AND CANADA ONLY

- I. We warrant each new production (not those made for high performance purposes) MerCruiser Sterndrive Power Package, Inboard Engine and accessories attached thereto, (hereafter referred to as "Product") to be free from defects in material and workmanship, but only when the customer purchases or obtains predelivery service from a Dealer authorized by us to distribute MerCruiser Product in the country in which the sale or predelivery service occurred.
- II. This warranty shall become effective only upon our receipt of a completed Warranty Registration Card, which shall identify the Product so registered by serial number. This warranty shall remain in effect for a period of one (1) year from date of purchase.
- III. Since this warranty applies to defects in material and workmanship, it does not apply to normal worn parts, adjustments, tune-ups or to damage caused by: 1) Neglect, lack of maintenance, accident, abnormal operation or improper installation or service; 2) Use of an accessory or part not manufactured or sold by us; 3) Operation with fuels, oils or lubricants which are not suitable for use with the Product; 4) Participating in or preparing for racing or other competitive activity or operating with a racing type lower unit; 5) Alteration or removal of parts; or 6) Water entering engine cylinder/s through the exhaust system or carburetor/s.
- IV. Reasonable access must be provided to the Product for warranty service. This warranty will not apply to: 1) Haul-out, launch, towing and storage charges; telephone or rental charges of any type, inconvenience, or loss of time or income; or other consequential damages; or 2) Removal and/or replacement of boat partitions or material because of boat design for necessary access to the Product.
- V. Claim shall be made under this warranty by delivering the Product for inspection to a MerCruiser dealer authorized to service the Purchaser's product. If purchaser cannot deliver Product to such authorized dealer, he may give notice in writing to the Company. We shall then arrange for the inspection and repair, provided such service is covered under this warranty. Purchaser shall pay for all related transportation charges and/or travel time. If the service is not covered by this warranty purchaser shall pay for all related labor and material and any other expenses associated with that service. Any Product or parts shipped by purchaser for inspection or repair must be shipped with transportation charges prepaid. The Warranty Registration Card is the only valid registration identification and must be presented at the time warranty service is required. Warranty claims will not be accepted without presentation of the Warranty Registration Card.
- VI. Our sole and exclusive obligation under this Warranty shall be limited to repairing a defective part, or at our option, refunding the purchase price or replacing such part or parts with new or Mercury certified remanufactured parts as shall be necessary to remedy any malfunction resulting from defects in material or workmanship as covered by this Warranty. We reserve the right to improve the design of any Product without assuming any obligation to modify any Product previously manufactured.
- VII. ALL INCIDENTAL AND/OR CONSEQUENTIAL DAMAGES ARE EXCLUDED FROM THIS WARRANTY. WARRANTIES OF MERCHANTABILITY AND FITNESS ARE EXCLUDED FROM THIS WARRANTY. IMPLIED WARRANTIES ARE LIMITED TO THE LIFE OF THIS WARRANTY. SOME STATES OR COUNTRIES DO NOT ALLOW LIMITATIONS ON HOW LONG AN IMPLIED WARRANTY LASTS OR THE EXCLUSION OR LIMITATION OF INCIDENTAL OR CONSEQUENTIAL DAMAGES, SO THE ABOVE LIMITATION OR EXCLUSIONS MAY NOT APPLY TO YOU.**
- VIII. This warranty gives you specific legal rights, and you may also have other legal rights which vary from state to state.

MerCruiser International Warranty - Gasoline Engines

OUTSIDE THE UNITED STATES AND CANADA

- I. We warrant each new production (not those made for high performance purposes) MerCruiser Stern-drive Power Package, Inboard Engine and accessories attached thereto, (hereafter referred to as "Product") to be free from defects in material and workmanship, but only when the customer purchases or obtains predelivery service from a Dealer authorized by us to distribute MerCruiser Product in the country in which the sale or predelivery service occurred. This warranty shall remain in effect for a period of one (1) year from date of purchase.
- II. Since this warranty applies to defects in material and workmanship, it does not apply to normal worn parts, adjustments, tune-ups or to damage caused by: 1) Neglect, lack of maintenance, accident, abnormal operation or improper installation or service; 2) Use of an accessory or part not manufactured or sold by us; 3) Operation with fuels, oils or lubricants which are not suitable for use with the Product; 4) Participating in or preparing for racing or other competitive activity or operating with a racing type lower unit; or 5) Alteration or removal of parts or 6) Water entering engine cylinder/s through exhaust system or carburetor/s.
- III. Reasonable access must be provided to the Product for warranty service. This warranty will not apply to: 1) Haul-out, launch, towing and storage charges, telephone or rental charges of any type, inconvenience, or loss of time or income or other consequential damages or 2) Removal and/or replacement of boat partitions or material because of boat design for necessary access to the Product.
- IV. Claim shall be made under this warranty by delivering the Product for inspection to a MerCruiser dealer authorized to service the Product. If purchaser cannot deliver Product to such authorized dealer, he may give notice in writing to the Marine Power Service Center or distributor. The Marine Power Service Center or distributor shall then arrange for the inspection and repair, provided such service is covered under this warranty. Purchaser shall pay for all related transportation charges and/or travel time. If the service is not covered by this warranty purchaser shall pay for all related labor and material, and any other expenses associated with that service. Any Product or parts shipped by purchaser for inspection or repair must be shipped with transportation charges prepaid.
- V. Purchaser must provide "proof of purchase" and substantiate "date of purchase" by presenting the "Purchaser's Copy" of the "Warranty Registration Card" or the plastic "Warranty Registration Card" to the dealer authorized to service the Product. If either of these items is not available purchaser must provide a copy of the original "Bill of Sale" (Sales Contract) for the Product to be serviced. Warranty claims will not be accepted until adequate "proof of purchase" is presented by purchaser and "date of purchase" has been substantiated.
- VI. Our sole and exclusive obligation under this Warranty shall be limited to repairing a defective part or AT OUR OPTION, refunding the purchase price or replacing such part or parts with new or Mercury certified remanufactured parts as shall be necessary to remedy any malfunction resulting from defects in material or workmanship as covered by this Warranty. We reserve the right to improve the design of any Product without assuming any obligation to modify any Product previously manufactured.

VII. ALL INCIDENTAL AND/OR CONSEQUENTIAL DAMAGES ARE EXCLUDED FROM THIS WARRANTY. WARRANTIES OF MERCHANTABILITY AND FITNESS ARE EXCLUDED FROM THIS WARRANTY. IMPLIED WARRANTIES ARE LIMITED TO THE LIFE OF THIS WARRANTY. SOME COUNTRIES DO NOT ALLOW LIMITATIONS ON HOW LONG AN IMPLIED WARRANTY LASTS OR THE EXCLUSION OR LIMITATION OF INCIDENTAL OR CONSEQUENTIAL DAMAGES, SO THE ABOVE LIMITATION OR EXCLUSIONS MAY NOT APPLY TO YOU.

- VIII. This warranty gives you specific legal rights, and you may also have other legal rights which vary from country to country.

MARINE POWER INTERNATIONAL
Division of Brunswick Corporation
Fond du Lac, Wisconsin 54935 U.S.A.

3 Year Limited Warranty Against Corrosion Failure

(Applicable In The United States, Canada And Australia)

- I. We warrant parts and assemblies of each 1988 and newer production MerCruiser (Product) sold with a one year limited Product warranty or the Bravo and TRS Drive Units on performance Products that have a 90 day limited warranty rendered inoperative as a direct result of corrosion, provided the following simple precautionary steps which are specified in Owner's Manuals have been taken:
 1. Specified maintenance procedures (such as replacement of sacrificial anodes, specified lubrication and touch-up of nicks and scratches) have been implemented on a timely basis.
 2. Recommended corrosion prevention devices have been employed (details below).
- II. This warranty shall become effective upon receipt of a completed standard Product warranty registration card and shall remain effective for a period of three years from the date of purchase.
- III. This warranty does not cover: (1) electrical system corrosion; (2) corrosion resulting from damage, abuse or improper service; (3) corrosion to accessories, instruments, steering systems; (4) damage due to marine growth; (5) Product sold with less than a one year limited Product warranty except for Bravo and TRS Drive Units; nor (6) Product used in commercial application.

IV. ALL INCIDENTAL AND/OR CONSEQUENTIAL DAMAGES ARE EXCLUDED FROM THIS WARRANTY. WARRANTIES OF MERCHANTABILITY AND FITNESS ARE EXCLUDED FROM THIS WARRANTY. IMPLIED WARRANTIES ARE LIMITED TO THE LIFE OF THIS WARRANTY. SOME COUNTRIES DO NOT ALLOW LIMITATIONS ON HOW LONG AN IMPLIED WARRANTY LASTS OR THE EXCLUSION OR LIMITATION OF INCIDENTAL OR CONSEQUENTIAL DAMAGES, SO THE ABOVE LIMITATION OR EXCLUSIONS MAY NOT APPLY TO YOU.

- V. This warranty gives you specific legal rights, and you may also have other legal rights which vary from state to state (or country to country).
- VI. Other details of this warranty are contained in paragraphs IV, V and VI of the (United States and Canada) Product Warranty, and paragraphs III, IV, V and VI of the (International) Product Warranty, contained in this manual, which paragraphs are incorporated herein by reference.

Mercury Marine products are built using the most advanced corrosion protection process available. This manufacturing system, complemented by dealer and customer participation in an anti-corrosion preventive maintenance program, provides protection against repair costs incurred by the effects of marine corrosion.

OWNER'S RESPONSIBILITY

Protection against certain types of corrosion damage must be provided by using such systems as the Quicksilver MerCathode System and/or Galvanic Isolator. These certain types of corrosion damage are: damage due to stray electrical currents (on-shore power connections, nearby boats, submerged metal), or improper application of copper base anti-fouling paint.

If anti-fouling protection is required, Tri-Butyl-Tin-Adipate (TBTA) base anti-fouling paints are recommended on MerCruiser boating applications. In areas where Tri-Butyl-Tin-Adipate base paints are prohibited by law, copper base paints can be used on the boat hull and transom. Do not apply paint to the MerCruiser drive unit or transom assembly. In addition, care must be taken to avoid an electrical interconnection between the MerCruiser Product and the paint. Corrosion damage that results from the improper application of copper base paint will not be covered by this limited warranty.

TRANSFER OF WARRANTY

This Limited Warranty is transferable to subsequent purchasers for the remainder of the unused portion of the 3-year limited corrosion warranty.

Warranty Coverage

The purpose of this section is to help eliminate some of the more common misunderstandings regarding warranty coverage. The table explains some of the types of services that are not covered by warranty.

Keep in mind that warranty covers repairs that are needed within the warranty period because of defects in material and workmanship. Installation errors, accidents, normal wear, and a variety of other causes that affect the product are not covered.

Warranty is limited to defects in material or workmanship, but only when the consumer sale is made in the country to which distribution is authorized by us.

Should you have any questions concerning warranty coverage, contact your authorized dealer. They will be pleased to answer any questions that you may have.

Warranty Does Not Apply To The Following:

- Minor adjustments and tune-ups, including checking, cleaning or adjusting spark plugs, ignition components, carburetor settings, filters, belts, controls, and checking lubrication made in connection with normal services.
- Damage caused by neglect, lack of maintenance, accident, abnormal operation or improper installation or service, or freezing temperatures.
- Haul-out, launch, towing charges; removal and/or replacement of boat partitions or material because of boat design for necessary access to the product; all related transportation charges and/or travel time, etc. Reasonable access must be provided to the product for warranty service. Customer must deliver product to an Authorized Dealer.
- Additional service work requested by customer other than that necessary to satisfy the warranty obligation.
- Labor performed by other than an Authorized Dealer may be covered only under following circumstances: When performed on emergency basis (providing there are no Authorized Dealers in area who can perform the work required or have no facilities to haul out, etc., and prior factory approval has been given to have the work performed at this facility).
- All incidental and/or consequential damages (storage charges, telephone or rental charges of any type, inconvenience or loss of time or income) are the owner's responsibility.
- Use of other than Quicksilver replacement parts when making warranty repairs.
- Oils, lubricants or fluids changed as a matter of normal maintenance is customer's responsibility unless loss or contamination of same is caused by product failure that would be eligible for warranty consideration.
- Participating in or preparing for racing or other competitive activity.
- Engine noise does not necessarily indicate a serious engine problem. If diagnosis indicates a serious internal engine condition which could result in a failure, condition responsible for noise should be corrected under the warranty.
- Lower unit and/or propeller damage caused by striking a submerged object is considered a marine hazard.
- Water entering the engine via the carburetor or exhaust system or submersion. Also water in the starter motor.
- Starter motors and/or armatures or field coil assembly, which are burned, or where lead is thrown out of commutator because of excess cranking.
- Valve or valve seat grinding required because of wear.
- Failure of any parts caused by lack of cooling water, which results from starting power package out of water, foreign material blocking inlets or power package being mounted too high.
- Use of fuels and lubricants which are not suitable for use with or on the product.
- Our limited warranty does not apply to any damage to our products caused by the installation or use of parts and accessories which are not manufactured or sold by us. Failures which are not related to the use of those parts or accessories, are covered under warranty, if they otherwise meet the terms of the limited warranty for that product.

Transferable Warranty

The product warranty is transferable to a subsequent purchaser, but only for the remainder of the unused portion of the limited warranty. This will not apply to products used for commercial applications.

Direct Sale By Owner

- The second owner can be registered as the new owner and retain the unused portion of the limited warranty by sending the former owner's plastic Owner Warranty Registration Card and a copy of the bill of sale to show proof of ownership. In the United States and Canada, mail to:

Mercury Marine

Attn: Warranty Registration Department

W6250 West Pioneer Road

P.O. Box 1939

Fond du Lac, WI 54936-1939

- A new Owner Warranty Registration Card will be issued with the new owner's name and address. Registration records will be changed on the factory computer registration file.
- There is no charge for this service.

Outside the United States and Canada, please contact the distributor in your country, or the Marine Power International Service Center closest to you, for the transferable warranty procedure that would apply to you.

CA765

Mercury Product Protection Plan

United States And Canada Only

(Certain performance products, triple engine installations, and commercial applications are excluded)

The Mercury Product Protection Plan provides coverage against unexpected mechanical and electrical breakdowns that may occur beyond the standard limited warranty.

The optional Mercury Product Protection Plan is the only Factory Plan available for your engine.

Two, three or four - year term plans can be purchased up to 12 months after the original engine registration date.

See your participating MerCruiser dealer for complete program details.

Read This Manual Thoroughly

IF YOU DON'T UNDERSTAND ANY PORTION, CONTACT YOUR DEALER FOR A DEMONSTRATION OF ACTUAL STARTING AND OPERATING PROCEDURES.

NOTICE

Throughout this publication, and on your power package, **WARNINGS** and **CAUTIONS**, accompanied by the International Hazard Symbol , may be used to alert the installer/user to special instructions concerning a particular service or operation that may be hazardous if performed incorrectly or carelessly. **Observe them carefully.**

These "Safety Alerts" alone cannot eliminate the hazards that they signal. Strict compliance with these special instructions while performing the service, plus "common sense" operation, are major accident prevention measures.

WARNING

WARNING-Hazards or unsafe practices which could result in severe personal injury or death.

CAUTION

CAUTION-Hazards or unsafe practices which could result in minor personal injury or product or property damage.

IMPORTANT: - Indicates information or instructions that are necessary for proper operation and /or maintenance.

WARNING

The operator (driver) is responsible for the correct and safe operation of the boat, the equipment aboard and the safety of all occupants aboard. We strongly recommend that the operator read this Operation, Maintenance and Warranty Manual and thoroughly understand the operational instructions for the power package and all related accessories before the boat is used.

THIS PAGE IS INTENTIONALLY BLANK

General Information

CA619

Lanyard Stop Switch

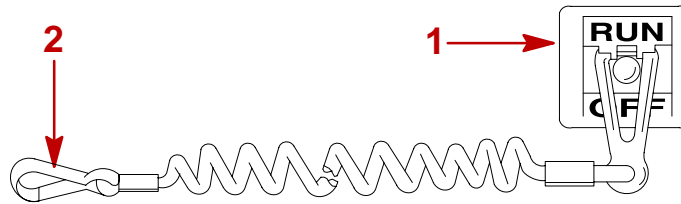

74608

The purpose of a lanyard stop switch (1) is to turn off the engine when the operator moves far enough away from the operator's position (as in accidental ejection from the operator's position) to activate the switch. Some remote control units are equipped with a lanyard stop switch. A lanyard stop switch can be installed on the dashboard or side adjacent to the operator's position.

The lanyard is a cord usually between 4 and 5 feet (1220 and 1524 mm) in length when stretched out with an element on one end made to be inserted into the switch and a snap (2) on the other end for attaching to the operator. The lanyard is coiled to make its at-rest condition as short as possible so as to minimize the likelihood of lanyard entanglement with nearby objects. It is made as long as it is in its stretched condition to minimize the likelihood of accidental activation should the operator choose to move around in an area close to the normal operator's position. If it is desired to have a shorter lanyard, wrap the lanyard around the operator's wrist or leg, or tie a knot in the lanyard.

IMPORTANT: The purpose of a lanyard stop switch is to stop the engine when the operator moves far enough away from the operator's position to activate the switch. This would occur if the operator accidentally falls overboard or moves within the boat a sufficient distance from the operator's position. Accidental ejections and falls overboard are more likely to occur in certain types of boats such as low sided sport boats or bass boats, and high-performance boats. Accidental ejections and falls overboard are also likely to occur as a result of poor operating practices such as sitting on the back of the seat or gunwale at planing speeds, standing at planing speeds, sitting on elevated fishing boat decks, operating at planing speeds in shallow or obstacle-infested waters, releasing your grip on a steering wheel that is pulling in one direction, drinking alcohol or consuming drugs, or daring, high-speed boat maneuvers.

While activation of the lanyard stop switch will stop the engine immediately, a boat will continue to coast for some distance depending upon the velocity and degree of any turn at shut-down. However, the boat will not complete a full circle. While the boat is coasting, it can cause injury to anyone in the boat's path as seriously as the boat would when under power.

We strongly recommend that other occupants be instructed on proper starting and operating procedures should they be required to operate the engine in an emergency (e.g. if the operator is accidentally ejected).

⚠ WARNING

Should the operator fall out of the boat, the possibility of serious injury or death from being run over by the boat can be greatly reduced by stopping the engine immediately. Always properly connect both ends of the stop switch lanyard to the stop switch and the operator.

Accidental or unintended activation of the switch during normal operation is also a possibility. This could cause any, or all, of the following potentially hazardous situations:

- 1 Occupants could be thrown forward due to unexpected loss of forward motion – a particular concern for passengers in the front of the boat who could be ejected over the bow and possibly struck by the gear case or propeller.
- 2 Loss of power and directional control in heavy seas, strong current or high winds.
- 3 Loss of control when docking.

⚠ WARNING

Avoid serious injury or death from deceleration forces resulting from accidental or unintended stop switch activation. The boat operator should never leave the operator's station without first disconnecting the stop switch lanyard from the operator.

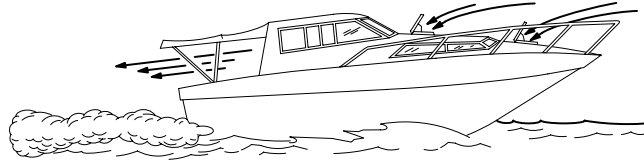

1

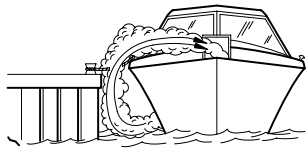

2A

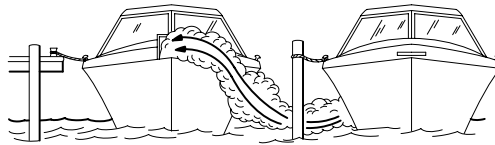

2B

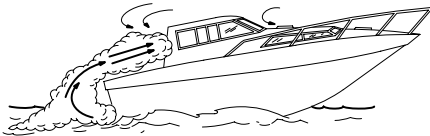

3A



3B

Exhaust Emissions

Be Alert To Carbon Monoxide Poisoning

Carbon monoxide is present in the exhaust fumes of all internal combustion engines including the outboards, stern drives and inboard engines that propel boats, as well as the generators that power various boat accessories. Carbon monoxide is a deadly gas that is odorless, colorless and tasteless.

Early symptoms of carbon monoxide poisoning which should not be confused with seasickness or intoxication, include headache, dizziness, drowsiness, and nausea.

WARNING

Avoid the combination of a running engine and poor ventilation. Prolonged exposure to carbon monoxide in sufficient concentration can lead to unconsciousness, brain damage or death.

GOOD VENTILATION

Ventilate passenger area, open side curtains, or forward hatches to remove fumes.

1 Example of desired air flow through the boat.

CA643

POOR VENTILATION

Under certain running and/or wind conditions, permanently enclosed or canvas enclosed cabins or cockpits with insufficient ventilation may draw in carbon monoxide. Install one or more carbon monoxide detectors in your boat.

Although the occurrence is rare, on a very calm day, swimmers and passengers in an unclosed area of a stationary boat that contains or is near a running engine may be exposed to a hazardous level of carbon monoxide.

2 Examples of poor ventilation while boat is stationary:

A Running the engine when the boat is moored in a confined space.

B Mooring close to another boat that has its engine running.

3 Examples of poor ventilation while boat is moving:

A Running the boat with the trim angle of the bow too high.

B Running the boat with no forward hatches open (station wagon effect).

Safe Boating Suggestions

In order to safely enjoy the waterways, familiarize yourself with local and other governmental boating regulations and restrictions, and consider the following suggestions.

- **Know and obey all nautical rules and laws of the waterways.** Boat operators should complete a boating safety course. Courses are offered in the U.S.A. by (1) The U.S. Coast Guard Auxiliary, (2) The Power Squadron, (3) The Red Cross and (4) your state or provincial boating law enforcement agency. Inquiries may be made to the Boating Hotline, 1-800-368-5647 or the Boat U.S. Foundation information number 1-800-336-BOAT.

We strongly recommend that all powerboat operators attend one of these courses.

You should also review the NMMA Sources of Waterway Information booklet. It lists regional sources of safety, cruising and local navigation and is available at no charge by writing to:

Sources of Waterway Information
National Marine Manufacturers Association
410 N. Michigan Avenue
Chicago, IL 60611 U.S.A.

- **Perform safety checks and required maintenance.** Follow a regular schedule and ensure that all repairs are properly made.
- **Check safety equipment on board.** Here are suggestions of the types of safety equipment to carry when boating:
 - 1 Approved fire extinguisher(s); paddle or oar.
 - 2 Signal devices: flashlight, rockets or flares, flag and whistle or horn.
 - 3 Spare propeller, thrust hubs and an appropriate wrench.
 - 4 Tools for necessary minor repairs; first aid kit and book.
 - 5 Anchor and extra anchor line; water-proof storage containers.
 - 6 Manual bilge pump and extra drain plugs; compass and map or chart of area.
 - 7 Spare operating equipment; batteries, bulbs, fuses, etc.
 - 8 Transistor radio.
 - 9 Drinking water.
- **Know signs of weather change and avoid foul weather and rough-sea boating.**
- **Tell someone where you are going and when you expect to return.**
- **Passenger boarding.** Stop the engine whenever passengers are boarding, unloading or are near the back (stern) of the boat. Just shifting the drive unit into neutral is not sufficient.
- **Use personal flotation devices.** Federal Law requires that there be a U.S. Coast Guard approved, wearable-type life jacket (personal flotation device), correctly sized and readily accessible for every person on board, plus a throwable cushion or ring. We strongly advise that everyone wear a life jacket at all times while in the boat.
- **Prepare other boat operators.** Instruct at least one person on board in the basics of starting and operating the engine and boat handling in case the driver becomes disabled or falls overboard.
- **Do not overload your boat.** Most boats are rated and certified for maximum load (weight) capacities (refer to your boat capacity plate). Know your boat's operating and loading limitations. Know if your boat will float if full of water. When in doubt, contact your dealer or the boats manufacturer.

- **Make sure everyone in the boat is properly seated.** Don't allow anyone to sit or ride on any part of the boat that was not intended for such use. This includes backs of seats, gunwales, transom, bow, decks, raised fishing seats, any rotating fishing seat; anywhere that sudden unexpected acceleration, sudden stopping, unexpected loss of boat control or sudden boat movement could cause a person to be thrown overboard or into the boat. See that all passengers have a proper seat and are in it before any boat movement.
- **Never be under the influence of alcohol or drugs while boating (it is the law).** They impair your judgment and greatly reduce your ability to react quickly.

CA282

Protecting People In The Water

While You Are Cruising

It is very difficult for a person standing or floating in the water to take quick action to avoid a boat heading in his/her direction even at slow speed.

Always slow down and exercise extreme caution any time you are boating in an area where there might be people in the water.

Whenever a boat is moving (coasting) and the drive unit is in neutral position, there is sufficient force by the water on the propeller to cause the propeller to rotate. This neutral propeller rotation can cause serious injury.

While Boat Is Stationary

Shift the drive unit into neutral and shut off the engine before allowing people to swim or be in the water near your boat.

WARNING

Stop your engine immediately whenever anyone in the water is near your boat. Serious injury to the person in the water is likely if contacted by a rotating propeller, a moving boat, a moving gear case, or any solid device rigidly attached to a moving boat or gear case.

CC828

High-Speed And High-Performance Boat Operation

If your boat is considered a high-speed or high-performance boat with which you are unfamiliar, we recommend that you never operate it at its high speed capability without first requesting an initial orientation and familiarization demonstration ride with your dealer or an operator experienced with your boat. For additional information, obtain a copy of our "Hi-Performance Boat Operation" booklet (Part Number 90-849250--1) from your dealer, distributor, or Mercury Marine.

Conditions Affecting Operation

Weight Distribution

Positioning of weight (passengers and gear) inside the boat has the following effects:

Shifting weight to rear (stern) will:

- Generally increases speed and engine RPM.
- At extremes can cause boat to porpoise.
- Causes bow to bounce in choppy water.
- Increases danger of following wave splashing into boat when coming off plane.

Shifting weight to front (bow) will:

- Improve ease of planing.
- Improve rough water ride.
- At extremes, can cause boat to veer back and forth (bow steer).

Bottom Of Boat

To maintain maximum speed, the following conditions of the boat bottom should be observed.

- A. Clean, free of barnacles and marine growth.
- B. Free of distortion; nearly flat where it contacts the water.
- C. Straight and smooth, fore and aft.

Marine vegetation may accumulate when boat is docked. This growth must be removed before operation; it may clog water inlets and cause engine to overheat.

Propeller Selection

IMPORTANT: Installed propeller must allow engine to run at its specified maximum wide-open-throttle revolutions per minute (rpm). Use an accurate service tachometer to verify engine operating rpm.

It is the responsibility of the boat manufacturer and/or the selling dealer to equip the power package with the correct propeller(s). Specified engine wide-open-throttle (WOT) and operating rpm range are listed in "SPECIFICATIONS".

IMPORTANT: The engines covered in this manual are equipped with an rpm rev-limiter that is set to an upper (or limited) rpm amount. This limit is slightly above the normal operating range of the engine and is designed to help prevent damage from excessive engine rpm. Once the rpm drop into the recommended operating rpm range normal engine operation resumes.

Select a propeller that will allow the engine power package to operate at or near the top end of the recommended wide-open-throttle operating rpm range with a normal load. Generally, there is a 150 rpm difference between 1 inch changes in propeller diameter or pitch.

If full throttle operation is below the recommended range, the propeller must be changed to prevent loss of performance and possible engine damage. On the other hand, operating an engine above the recommended operating rpm range will cause higher than normal wear and/or damage.

After initial propeller selection, the following common problems may require that the propeller be changed to a lower pitch:

- Warmer weather and greater humidity cause an rpm loss.
- Operating in a higher elevation causes an rpm loss.
- Operating with a damaged propeller or dirty boat bottom causes an rpm loss.
- Operating with increased load (additional passengers, pulling skiers, etc.).

For better acceleration, such as is needed for water skiing, use the next lower pitch propeller. However, do not operate at full throttle when using the lower pitch propeller but not pulling skiers.

How Elevation And Climate Affect Performance

Elevation has a very noticeable effect on the wide-open-throttle power of an engine. Since air (containing oxygen) gets thinner as elevation increases, the engine begins to starve for air. Humidity, barometric pressure and temperature do have a noticeable effect on the density of air. Heat and humidity thin the air. This condition can become particularly annoying when the propeller testing was done on a cool, dry day. Then later; on a hot, sultry day, the boat doesn't seem to have the same performance.

Although some performance can be regained by dropping to a lower pitch propeller, the basic problem still exists. In some cases, a gear ratio change to more reduction is possible and very beneficial.

Summer conditions of high temperature, low barometric pressure and high humidity all combine to reduce the engine power. This, in turn, is reflected in decreased boat speeds, as much as 2 or 3 miles per hour in some cases. Nothing will regain this speed for the boater, but the coming of cool, dry weather.

In pointing out the practical consequences of weather effects, an engine running on a hot, humid, summer day, may encounter a loss of as much as 14% of the horsepower it would produce on a dry, brisk spring or fall day. With the drop in available horsepower, this propeller will, in effect, become too large. Consequently, the engine operates at less than its recommended RPM. This will result in further loss of horsepower at the propeller with another decrease in boat speed. This secondary loss, however, can be somewhat regained by switching to a lower-pitch propeller that allows the engine to again run at recommended RPM.

For boaters to realize optimum engine performance under changing weather conditions, it is essential that the engine be propped to allow it to operate at or near the top end of the recommended maximum RPM range at wide-open-throttle with a normal boat load.

Not only does this allow the engine to develop full power, but equally important is the fact that the engine also will be operating in an RPM range that discourages damaging detonation. This, of course, enhances overall reliability and durability of the engine.

Important Information

Operation And Maintenance

OWNER/OPERATOR RESPONSIBILITIES

It is the operator's responsibility to perform all safety checks; to ensure that all lubrication and maintenance instructions are complied with for safe operation and to return the unit to an Authorized MerCruiser Dealer for a periodic checkup.

Normal maintenance service and replacement parts are the responsibility of the owner/operator and as such, are not considered defects in workmanship or material within the terms of the warranty. Individual operating habits and usage contribute to the need for maintenance service.

Proper maintenance and care of your power package will assure optimum performance and dependability, and will keep your overall operating expenses at a minimum. See your Authorized MerCruiser Dealer for service aids.

CA14

DEALER RESPONSIBILITIES

In general, a dealer's responsibilities to the customer include predelivery inspection and preparation such as:

- Make sure that the boat is properly equipped.
- Prior to delivery, make certain that the MerCruiser power package and other equipment are in proper operating condition.
- Make all necessary adjustments for maximum efficiency.
- Familiarize the customer with the on-board equipment.
- Explain and demonstrate the operation of the power package and boat.
- At the time of delivery, the dealer should provide you with a copy of a Predelivery Inspection Checklist.
- Your selling dealer should fill out the Warranty Registration Card completely and mail it to the factory immediately upon sale of the new product.

CA407

Freezing Temperature Operation

IMPORTANT: If boat is operated during periods of freezing temperature, precautions must be taken to prevent freezing damage to power package. Damage caused by freezing IS NOT covered by MerCruiser Limited Warranty.

CA408

Drain Plug and Bilge Pump

The engine compartment in your boat is a natural place for water to collect. For this reason, boats are normally equipped with a drain plug and/or a bilge pump. It is very important to check these items on a regular basis to ensure that the water level does not rise to come in contact with your power package. Components on your engine will be damaged if submerged. Damage caused by submersion is not covered by the MerCruiser Limited Warranty.

CA409

Attention Required After Submersion

- Before recovery, contact an Authorized MerCruiser Dealer.
- After recovery, immediate service by an Authorized MerCruiser Dealer is required to prevent serious damage to power package.

Launching And Boat Operation Care

⚠ CAUTION

During launching from a trailer, if the unloading ramp is steep or the trailer bed must be tilted, the boat may enter the water rapidly and at a steep angle. This may force water through the exhaust system into the cylinders. The more weight on the transom, the more likely this is to occur.

Slowing down rapidly or stopping suddenly may cause a following wave to “swamp” the transom. In this instance, water may enter the cylinders through the exhaust system.

When backing up rapidly, the same situation may occur as stated in the preceding paragraph.

In any of these situations, water entering the engine could cause severe damage to internal parts. Refer to “Attention Required After Submersion”.

Stolen Power Package

If your power package is stolen, immediately advise the local authorities and Mercury Marine of the model and serial number(s) and to whom the recovery is to be reported. This “Stolen Motor” information is placed into a file at Mercury Marine to aid authorities and dealers in recovery of stolen motors.

Replacement Service Parts

⚠ WARNING

Electrical, ignition and fuel system components on MerCruiser gasoline power packages are designed and manufactured to comply with U.S. Coast Guard rules and regulations to minimize risks of fire or explosion.

Use of replacement electrical, ignition or fuel system components, which do not comply to these rules and regulations, could result in a fire or explosion hazard and should be avoided.

When servicing the electrical, ignition and fuel systems, it is extremely important that all components are properly installed and tightened. If not, any electrical or ignition component could permit sparks to ignite fuel vapors from fuel system leaks, if they existed.

Marine engines are expected to operate at or near full-throttle for most of their life. They are also expected to operate in both fresh and saltwater environments. These conditions require numerous special parts. Care should be exercised when replacing marine engine parts as specifications are quite different from those of the standard automotive engine.

For example, one of the most important, and probably the least suspected special replacement part, is the cylinder head gasket. Since saltwater is highly corrosive, the steel-type automotive head gasket cannot be used. A marine engine head gasket uses special materials to resist corrosive action.

Since marine engines must be capable of running at or near maximum RPM much of the time, special valve springs, valve lifters, pistons, bearings, camshafts and other heavy-duty moving parts are required for long life and peak performance.

These are but a few of the many special modifications that are required in MerCruiser marine engines to provide long life and dependable performance.

Do-It-Yourself Maintenance Suggestions

If you are one of those persons who likes to do-it-yourself, here are some suggestions for you.

- Present-day marine equipment, such as your MerCruiser power package, are highly technical pieces of machinery. Electronic ignition and special fuel delivery systems provide greater fuel economies, but also are more complex for the untrained mechanic.
- Do not attempt any repairs which are not covered in this manual unless you are aware of the precautions (“Cautions” and “Warnings”) and procedures required. Your safety is of our concern.
- If you attempt to service the product yourself, we suggest you order the service manual for that model. This manual outlines the correct procedures to follow. Do not attempt repairs if you do not understand the procedures.
- There are special tools and equipment that are required to perform some repairs. Do not attempt these repairs unless you have these special tools and/or equipment. You can cause damage to the product in excess of the cost a dealer would charge you.
- Also, if you partially disassemble an engine or drive assembly and are unable to repair it, the dealer's mechanic must reassemble the components and test to determine the problem. This will cost you more than taking it to the dealer immediately upon having a problem. It may be a very simple adjustment to correct the problem.
- Do not telephone the dealer, service office or the factory to attempt for them to diagnose a problem or request the repair procedure. It is difficult for them to diagnose a problem over the telephone.
- Your Authorized Dealer is there to service your power package. They have qualified factory-trained mechanics.

It is recommended you have the dealer do periodic maintenance checks on your power package. Have them winterize it in the fall and service it before the boating season. This will reduce the possibility of any problems occurring during your boating season when you want trouble-free boating pleasure.

Multiple EFI Engine Battery Precautions

Situation

Alternators: Alternators are designed to charge the battery that supplies electrical power to the engine that the alternator is mounted on. When batteries for two different engines are connected, one alternator will supply all of the charging current for both batteries. Normally, the other engine's alternator will not be required to supply any charging current.

EFI Electronic Control Module (ECM): The ECM requires a stable voltage source. During multiple engine operation, an onboard electrical device may cause a sudden drain of voltage at the engine's battery. The voltage may go below the ECM's minimum required voltage. Also, the alternator on the other engine may now start charging. This could cause a voltage spike in the engine's electrical system.

In either case, the ECM could shut off. When the voltage returns to the range that the ECM requires, the ECM will reset itself. The engine will now run normally. This ECM shut down usually happens so fast that the engine just appears to have an ignition miss.

Recommendations

Batteries: Boats with multi-engine EFI power packages require each engine be connected to its own battery. This ensures that the engine's Electronic Control Module (ECM) has a stable voltage source.

Battery Switches: Battery switches should always be positioned so each engine is running off its own battery. DO NOT operate engines with switches in **BOTH** or **ALL** position. In an emergency, another engine's battery can be used to start an engine with a dead battery.

Battery Isolators: Isolators can be used to charge an auxiliary battery used for powering accessories in the boat. They should not be used to charge the battery of another engine in the boat unless the type of isolator is specifically designed for this purpose.

Generators: The generator's battery should be considered another engine's battery.

Diagnosing EFI Problems (If Equipped)

NOTE: All references to EFI models apply to EFI and MPI engines.

Your Authorized MerCruiser Dealer has the proper service tools for diagnosing problems on Electronic Fuel Injection (EFI) Systems. The Electronic Control Module (ECM) on these engines have the ability to detect some problems with the system when they occur, and store a "Trouble Code" in the ECM's memory. This code can then be read later by a service technician using a special diagnostic tool.

Water Separating Fuel Filter

CAUTION

The electric fuel pump and factory installed water separating fuel filter have been carefully designed to function properly together. Do not install additional fuel filters and/or water separating fuel filters between fuel tank and engine.

The installation of additional filters may cause:

- Fuel Vapor Locking
- Difficult Warm-Starting
- Piston Detonation Due to Lean Fuel Mixture
- Poor Driveability

CA413

20-Hour Break-In Period

IMPORTANT: The first 20 hours of operation is the engine break-in period. Correct break-in is essential to obtain minimum oil consumption and maximum engine performance. During this break-in period, the following rules must be observed:

- Do not operate below 1500 RPM for extended periods of time for first 10 hours. Shift into gear as soon as possible after starting and advance throttle above 1500 RPM **if conditions permit safe operation.**
- Do not operate at one speed consistently for extended periods.
- Do not exceed 3/4 throttle during first 10 hours. During next 10 hours, occasional operation at full throttle is permissible (5 minutes at a time maximum).
- Avoid full throttle acceleration from IDLE speed.
- Do not operate at full throttle until engine reaches normal operating temperature.
- Frequently check crankcase oil level. Add oil if needed. It is normal for oil consumption to be high during break-in period.

CA211

After Break-In Period

To help extend the life of your MerCruiser power package, the following recommendations should be considered;

- Use a propeller that allows the engine to operate at or near the top of the maximum RPM range (See “Specifications” section) when at full throttle with a normal boat load.
- Operation at 3/4 throttle setting or lower is recommended. Refrain from prolonged operation at maximum (full throttle) RPM.

CA414

End of First Season Checkup

At the end of the first season of operation, an Authorized MerCruiser Dealer should be contacted to discuss and/or perform various scheduled maintenance items. If you are in an area where the product is operated continuously (year-round operation), you should contact your dealer at the end of the first 100 hours of operation, or once yearly, whichever occurs first.

Operation

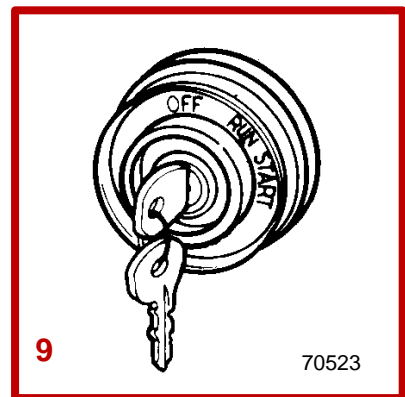
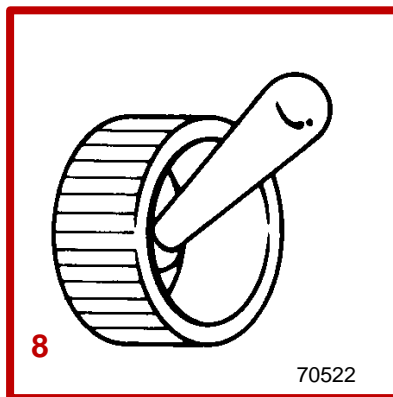
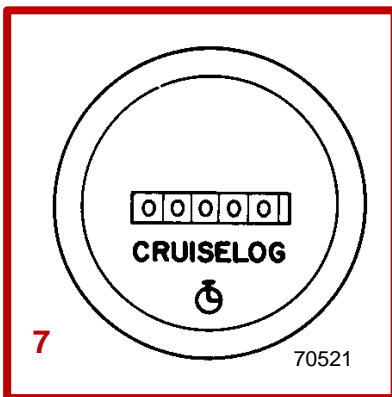
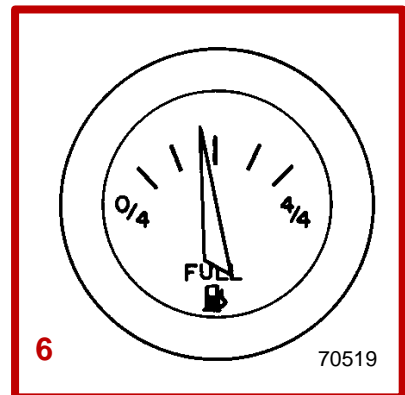
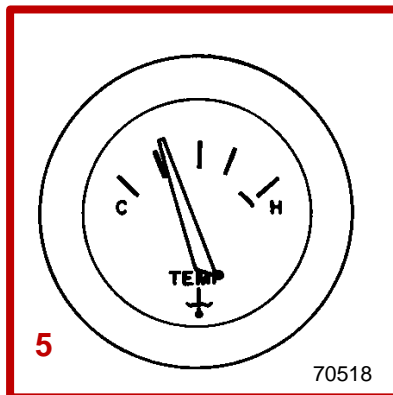
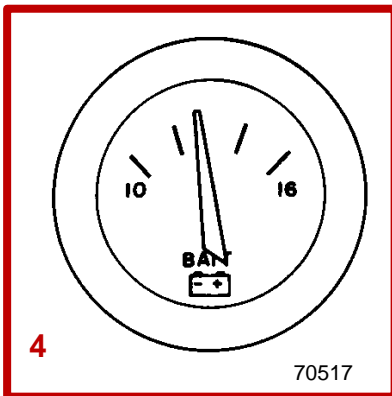
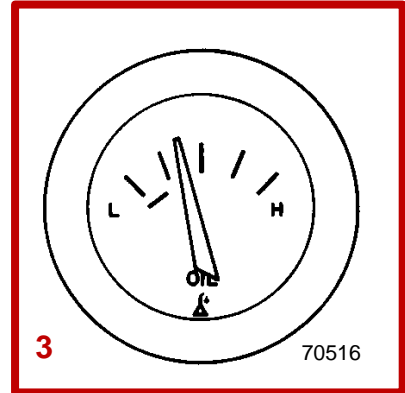
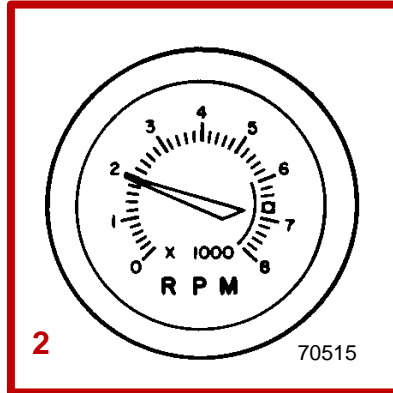
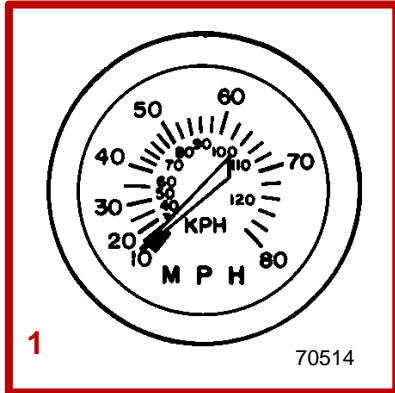

Instrumentation

The following is a brief explanation of instrumentation typically found on some boats. The owner/operator should be familiar with all instruments and their functions on the boat.

- 1 **Speedometer** - indicates boat speed.
- 2 **Tachometer** - indicates engine RPM.
- 3 **Oil Pressure Gauge** - indicates engine oil pressure.
- 4 **Battery Meter** - indicates battery voltage.
- 5 **Water Temperature Gauge** - indicates engine operating temperature.
- 6 **Fuel Gauge** - Indicates quantity of fuel in tank.
- 7 **Hour Meter** - records engine running time.
- 8 **Bilge Blower Switch** - Operates bilge blower (If equipped - See "Starting, Shifting and Stopping").
- 9 **Ignition Switch** - allows operator to start and stop engine.

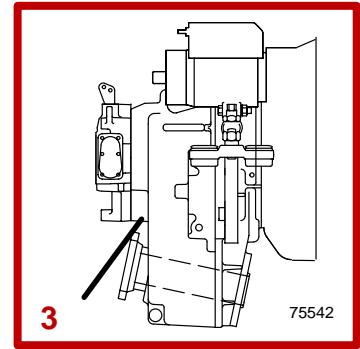
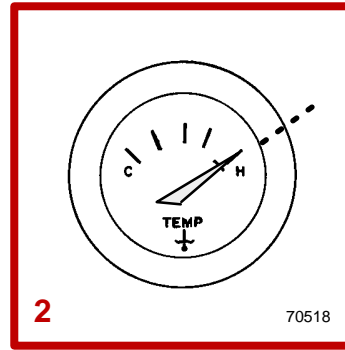
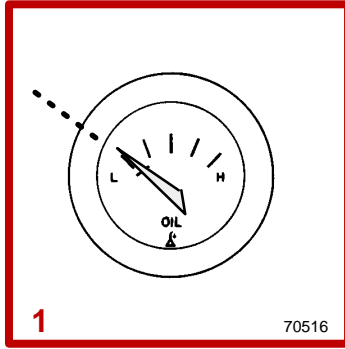

Audio Warning System

Your MerCruiser power package may be equipped with an Audio Warning System.

The audio warning system buzzer will sound if one of the following occur:

- 1 Engine Oil Pressure Too Low
- 2 Engine Temperature Too Hot
- 3 Transmission Fluid Temperature Too Hot

NOTE: To test the system:

Turn the ignition switch to the ON position without cranking the engine. The buzzer will sound if the system is working correctly.

CAUTION

Avoid engine damage. Do not operate engine once the buzzer has sounded EXCEPT TO AVOID A HAZARDOUS SITUATION. The Audio Warning System will not protect the engine from damage. It is designed to warn the operator that a problem has occurred.

When the buzzer sounds with the engine running, stop engine immediately. Investigate cause and correct it, if possible. If cause cannot be determined, consult your Authorized MerCruiser Dealer.

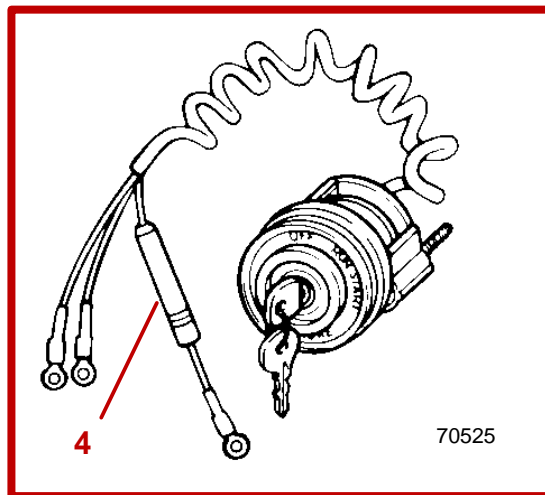
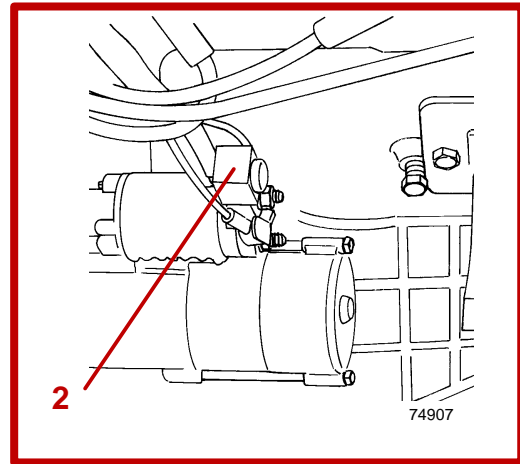
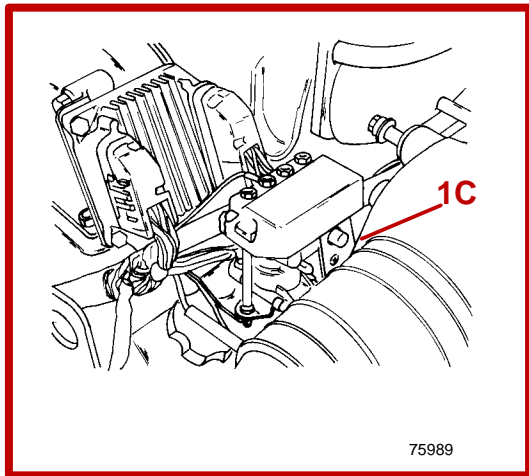
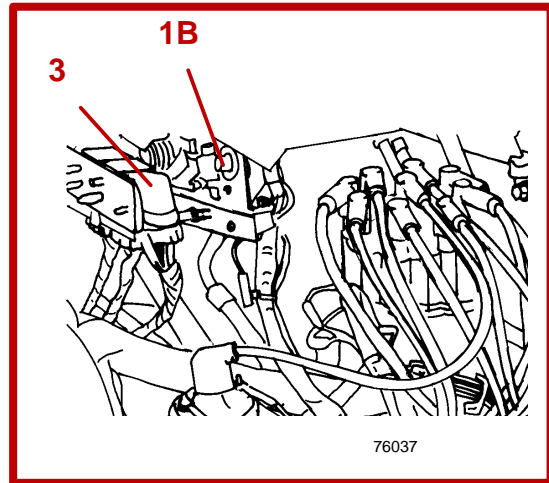
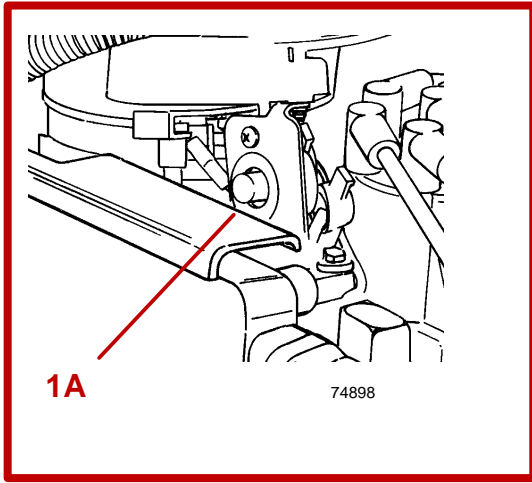

Electrical System Overload Protection

If an electrical overload occurs, a fuse will blow or the circuit breaker will trip open. The cause must be found and corrected before replacing fuse or resetting circuit breaker.

1 A circuit breaker provides protection for engine wiring harness and instrumentation power lead. Reset by pushing RESET button IN.

A Carburetor Models

B EFI Models Except 7.4L MPI

C 7.4L MPI

NOTE: *In an emergency, when engine must be operated and cause for high current draw cannot be located and corrected, turn OFF or disconnect all accessories connected to engine and instrumentation wiring. Reset circuit breaker. If breaker remains open, electrical overload has not been eliminated. Further checks must be made on electrical system.*

2 A 90 Amp fuse is located on the large post of the starter solenoid. This fuse is designed to protect the engine wiring harness if an electrical overload occurs.

3 On EFI Models: Three fuses are located on the port side of the engine. These fuses control various EFI circuits.

A Fuel Pump Fuse - 15 Amp

B ECM / Injector Fuse - 10 Amp

C ECM / Battery Fuse - 15 Amp

4 A 20 amp fuse may be located in ignition switch "I" terminal lead to protect electrical system. Check for blown fuse if key is turned to START and nothing happens (and circuit breaker is not tripped).

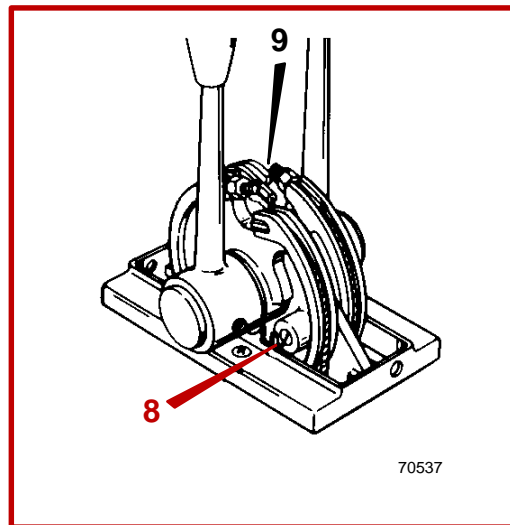
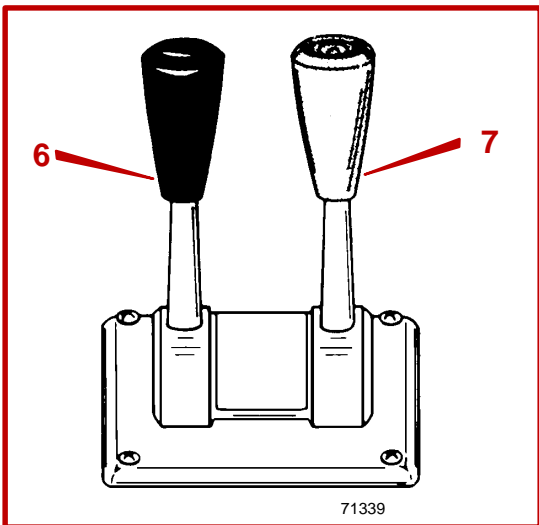
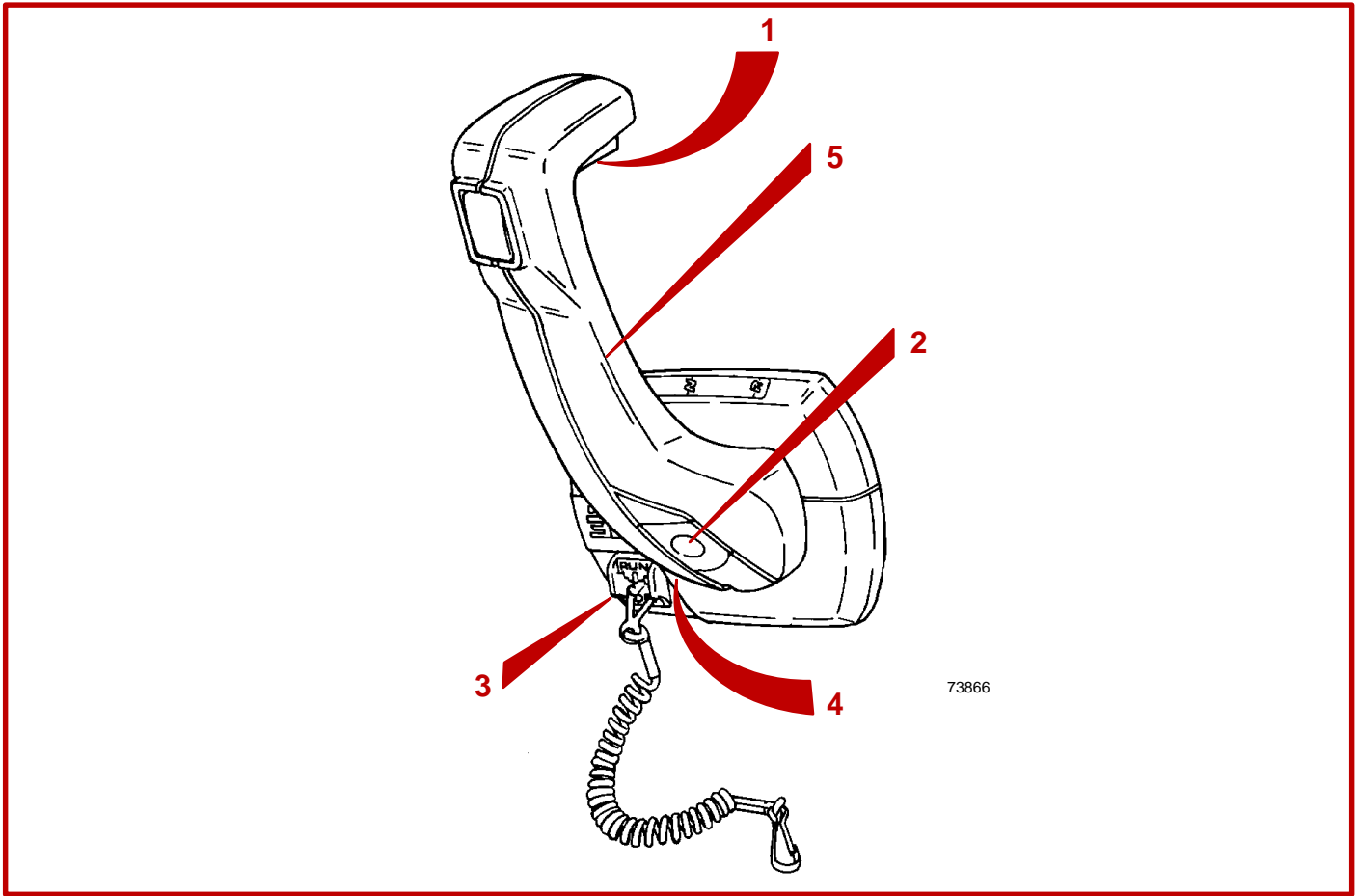

Remote Controls (Panel Mounted)

- 1 Neutral Lock Bar** - Prevents accidental shift and throttle engagement. Neutral lock bar must be pulled “Up” to move the control handle out of neutral.
- 2 Throttle Only Button** - Allows engine throttle advancement without shifting the engine. This is done by disengaging the shift mechanism from the control handle. The throttle only button can be depressed only when the remote control handle is in the “Neutral” position, and should only be used to assist in starting the engine.
- 3 Lanyard Stop Switch** - Turns ignition “Off” whenever the operator (when attached to the lanyard) moves far enough away from the operator’s position to activate the switch. See “Lanyard Stop Switch” at the front of this manual for safety warning on the use of this switch.
- 4 Control Handle Tension Adjustment Screw** - This screw can be adjusted to “Increase” or “Decrease” the tension on the control handle. This will help prevent “Creep” of the remote control handle. Turn screw “Clockwise” to increase tension and “Counterclockwise” to decrease tension. Adjust to tension desired.
- 5 Control Handle** - Operation of the shift and throttle are controlled by the movement of the control handle. “Push” the control handle forward from “Neutral” with a quick firm motion to the first detent for “Forward” gear. Continue pushing forward to increase speed. Pull the control handle back from “Neutral” with a quick firm motion to the first detent for “Reverse” gear. Continue pulling back to increase speed.

⚠ CAUTION

DO NOT shift the control handle into “Reverse” when the engine is not running. Forcing the shift mechanism into “Reverse” when the engine is not running could damage the remote control mechanism.

Remote Controls (Two Lever)

Your boat may be equipped with one of many Quicksilver® remote controls available. All controls feature an integral safety switch that allows starting engine in NEUTRAL only. Also, all controls may not have all features shown.

NOTE: If boat is equipped with a remote control other than shown, consult your dealer for a description and/or demonstration of the control.

- 6 Shift Lever** - shifts unit into gear with full lever movement. Move lever forward to shift to FORWARD gear. Move lever backward to shift to REVERSE gear. Lever in full vertical position shifts to NEUTRAL.

⚠ CAUTION

Never shift unit into or out of gear unless throttle lever is at idle RPM.

- 7 Throttle Lever** - allows engine RPM to be increased or decreased.
- 8 FRICTION Screw** - adjusts control handle friction so motor speed can be set and driver does not have to hold handle.
Turn screw clockwise to increase friction. Do not thread screw all the way out.
- 9 DETENT Screw** - controls the effort needed to move control handle out of NEUTRAL. To increase tension, turn screw clockwise; to decrease, turn screw counterclockwise. Do not thread screw all the way out.

IMPORTANT: Boats equipped with dual power packages may have both shift levers on one control and both throttle levers on the other control.

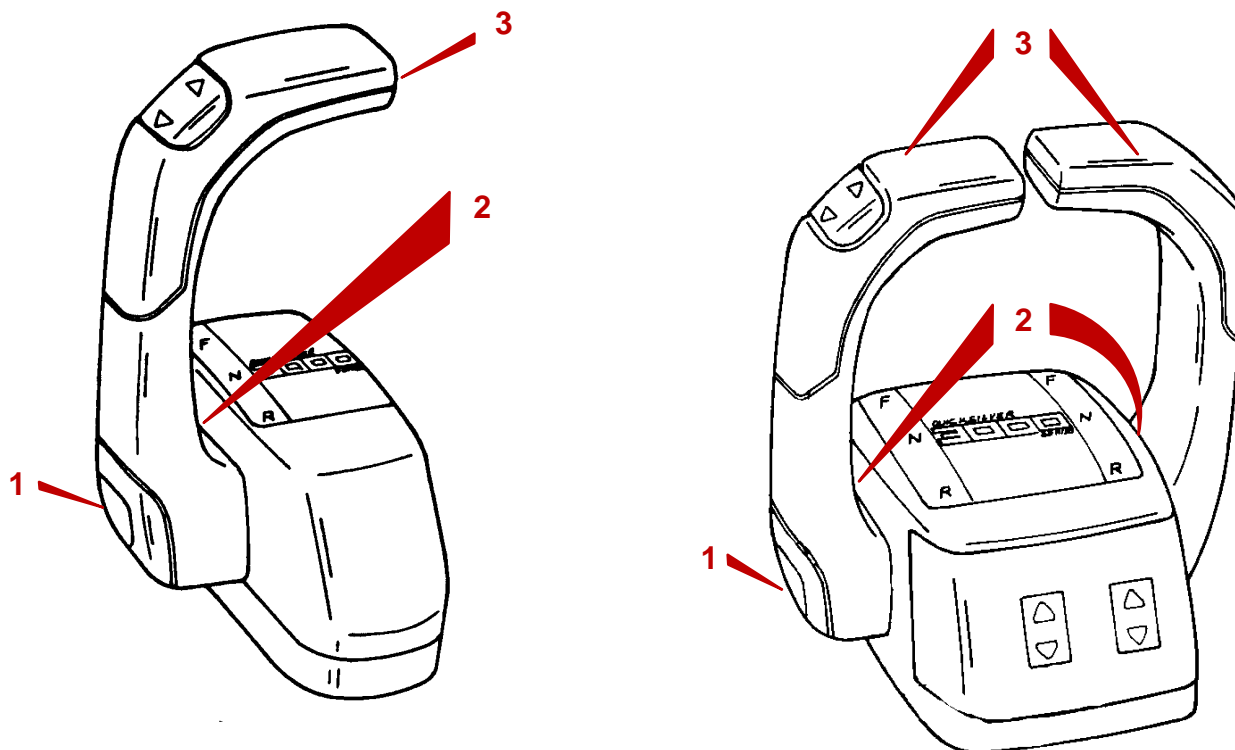

CE159

Remote Controls (Console Mounted)

Your boat may be equipped with one of many Quicksilver® remote controls available. All controls feature an integral safety switch that allows starting engine in NEUTRAL only. Also, all controls may not have all features shown.

NOTE: If boat is equipped with a remote control other than shown, consult your dealer for a description and/or demonstration of the control.

1 Throttle Only Button - Allows engine throttle advancement without shifting the engine. This is done by disengaging the shift mechanism from the control handle. The throttle only button can be depressed only when the remote control handle is in the “Neutral” position, and should only be used to assist in starting the engine.

2 Control Handle Tension Adjustment Screw - This screw can be adjusted to “Increase” or “Decrease” the tension on the control handle (cover must be removed to adjust). This will help prevent “Creep” of the remote control handle. Turn screw “Clockwise” to increase tension and “Counterclockwise” to decrease tension. Adjust to tension desired.

3 Control Handle(s) - Operation of the the shift and throttle are controlled by the movement of the control handle. “Push” the control handle forward from “Neutral” with a quick firm motion to the first detent for “Forward” gear. Continue pushing forward to increase speed. Pull the control handle back from “Neutral” with a quick firm motion to the first detent for “Reverse” gear. Continue pushing back to increase speed.

Starting, Shifting And Stopping

WARNING

Before starting engine, operate bilge blower for at least five minutes to remove any explosive fumes from engine compartment. If boat is not equipped with a bilge blower, open engine hatch and leave open while starting engine.

CAUTION

It is good practice to ventilate the engine compartment prior to servicing any engine components to remove any fuel vapors which may cause difficulty breathing or be an irritant.

IMPORTANT: Observe the following:

- Do not start engine without water being supplied to seawater pickup pump (to prevent pump or engine damage).
- Do not operate starter motor continuously for more than 30 seconds.
- On Carbureted Engines: When engine starts, quickly reduce throttle setting to avoid exceeding 1500 RPM.
- Never shift drive unit unless engine is at Idle RPM.

Perform the following as appropriate:

- 1 Check all items listed in OPERATION CHART.
- 2 Perform any other necessary checks, as indicated by your dealer, or specified in your boat owner's manual.
- 3 Place control handle in NEUTRAL.
- 4 Refer to A or B as appropriate for your model.
- A Carbureted Engine - Push THROTTLE ONLY button and position throttle setting as follows:
 - COLD ENGINE** - Move control/throttle lever to full throttle, then return to about 1/4 throttle. In extreme cold it may be necessary to pump lever more than once.
 - WARM ENGINE** - Move control/throttle lever to 1/4 throttle position.
 - FLOODED ENGINE** - Move control/throttle lever to full throttle. Be prepared to decrease engine speed to 1000-1500 RPM as soon as engine starts.
- B EFI Engine - Position throttle setting as follows:
 - COLD ENGINE** - Leave in neutral/idle speed position.
 - WARM ENGINE** - Leave in neutral/idle speed position.
 - FLOODED ENGINE** - Turn ignition switch to ON position. Push the THROTTLE ONLY button and place the throttle lever at 50% position. Attempt to start engine. As soon as engine starts, return throttle to the idle position.
- 5 Turn ignition key to START. Release key when engine starts and allow switch to return to RUN position.
- 6 Carbureted Engines - Move control / throttle lever back to decrease engine RPM to 1000-1500 RPM if necessary.
- 7 Check oil pressure gauge immediately after engine starts. If oil pressure is not within specified range (see SPECIFICATIONS), stop engine immediately and determine cause.
- 8 If engine is cold, run engine for 1 or 2 minutes at fast idle (1000-1500 RPM).
- 9 After engine has warmed up, check water temperature gauge to ensure that engine temperature is not abnormally high. If it is, stop engine immediately and determine cause.
- 10 Be sure charging system is functioning correctly.
- 11 Observe power package for fuel, oil, water and exhaust leaks.
- 12 To shift unit into gear, move control/shift lever with a firm, quick motion forward to shift to FORWARD gear, or backward to shift to REVERSE. After shifting unit, advance throttle to desired setting.

13 To shift unit out of gear, move control/shift lever to NEUTRAL and allow engine to drop to IDLE speed. If engine has been run at high speed for a long period of time, allow engine to cool by running at IDLE speed for 3 to 5 minutes.

14 Turn ignition key to OFF.

CC829

⚠ CAUTION

To avoid possible ingestion of water that can damage engine components:

- Do not turn the ignition key off when the engine is running above idle speed.
- Do not use the lanyard stop switch to shut off the engine above idle speed.
- When coming off plane, if a large following wave may roll over the boat's transom, apply a short, light burst of throttle to minimize the wave action against the stern of the boat.
- Do not come off plane quickly, shift into reverse and shut off engine.

CC683

Operation Chart

BEFORE STARTING	AFTER STARTING	WHILE UNDERWAY	AFTER STOPPING
Open engine hatch.	Observe all gauges to check condition of engine. If not normal, stop engine.	Observe all gauges to monitor engine condition. If not normal, stop engine.	Turn ignition key off.
Check engine oil level.	Check for fuel, oil, water, fluid and exhaust leaks, ect.		Turn battery switch OFF (if equipped).
Turn battery switch ON (if equipped).	Check shift and throttle control operation.		Close fuel valve (if equipped).
Operate bilge blowers (if equipped).	Check steering operation.		Close seacock (if equipped).
Open fuel shutoff valve (if equipped).			Flush cooling system (if in saltwater area).

Specifications

Fuel Recommendations

IMPORTANT: Use of improper gasoline can damage your engine seriously. Engine damage resulting from use of improper gasoline is considered misuse of engine, and damage caused thereby will not be covered under the limited warranty.

FUEL RATINGS

MerCruiser engines will operate satisfactorily when using a major brand of unleaded gasoline as follows:

USA and Canada - having a posted pump Octane Rating of 87 (R+M)/2 minimum. Premium gasoline [92 (R+M)/2 Octane] is also acceptable. DO NOT use leaded gasoline.

Outside USA and Canada - having a posted pump Octane Rating of 90 RON minimum. Premium gasoline (98 RON) is also acceptable. If unleaded gasoline is not available, use a major brand of leaded gasoline.

CA291

USING REFORMULATED (OXYGENATED) GASOLINES (USA ONLY)

This type of gasoline is required in certain areas of the USA. The two types of “oxygenates” used in these fuels is Alcohol (Ethanol) or Ether (MTBE or ETBE). If Ethanol is the “oxygenate” that is used in the gasoline in your area, refer to “Gasolines Containing Alcohol” also.

These “Reformulated Gasolines” are acceptable for use in your MerCruiser engine.

CA618

GASOLINES CONTAINING ALCOHOL

If the gasoline in your area contains either “methanol” (methyl alcohol) or “ethanol” (ethyl alcohol), you should be aware of certain adverse effects that can occur. These adverse effects are more severe with “methanol”. Increasing the percentage of alcohol in the fuel can also worsen these adverse effects.

Some of these adverse effects are caused because the alcohol in the gasoline can absorb moisture from the air, resulting in a separation of the water/alcohol from the gasoline in the fuel tank.

The fuel system components on your MerCruiser engine will withstand up to 10% alcohol content in the gasoline. We do not know what percentage your boat’s fuel system will withstand. Contact your boat manufacturer for specific recommendations on the boat’s fuel system components (fuel tanks, fuel lines, and fittings). Be aware that gasolines containing alcohol may cause increased:

- Corrosion of metal parts.
- Deterioration of rubber or plastic parts.
- Fuel permeation through rubber fuel lines.
- Starting and operating difficulties.

WARNING

FIRE AND EXPLOSION HAZARD: Fuel leakage from any part of fuel system can be a fire and explosion hazard which can cause serious bodily injury or death. Careful periodic inspection of entire fuel system is mandatory, particularly after storage. All fuel components including fuel tanks, whether plastic metal or fiberglass, fuel lines, fittings, fuel filters and carburetors/fuel injection components should be inspected for leakage, softening, hardening, swelling or corrosion. Any sign of leakage or deterioration requires replacement before further engine operation.

Because of possible adverse effects of alcohol in gasoline, it is recommended that only alcohol-free gasoline be used where possible. If only fuel containing alcohol is available, or if the presence of alcohol is unknown, increased inspection frequency for leaks and abnormalities is required.

IMPORTANT: When operating a MerCruiser engine on gasoline containing alcohol, storage of gasoline in the fuel tank for long periods should be avoided. Long periods of storage, common to boats, create unique problems. In cars alcohol-blend fuels normally are consumed before they can absorb enough moisture to cause trouble, but boats often sit idle long enough for phase separation to take place. In addition, internal corrosion may take place during storage if alcohol has washed protective oil films from internal components.

CC540

Seacock Size Recommendation

Seacock used, must have an internal cross-sectional area equal to or greater than hose to prevent restricting waterflow. Install valve in an area where it will be easily accessible and supported adequately to prevent hose fatigue. A 1-1/4 in. (32mm) brass ball or gate valve is suggested.

CC16

Sea Strainer Recommendation

Strainer used must be of sufficient size to ensure that an adequate supply of water will be maintained for cooling engine. A minimum of 30 gallons per minute (114 litres per minute) flow rate, is required.

CA693

Crankcase Oil

To help obtain optimum engine performance and to provide maximum protection, we strongly recommend the use of Quicksilver 4-Cycle 25W-40 Marine Engine Oil. This oil is a special blend of 25-weight and 40-weight oils for marine engines. If not available, a good grade, straight weight, detergent automotive oil of correct viscosity, with an API classification of SH, CF/CF-2, may be used.

In those areas where Quicksilver 4-Cycle 25W-40 Marine Engine Oil or a recommended straight weight oil are not available, a multi-viscosity 20W-40 or, as a second but less preferable choice, 20W-50, with API service ratings of SH, CF/CF-2 may be used.

IMPORTANT: The use of non-detergent oils, multi-viscosity oils (other than Quicksilver 25W-40 or a good quality 20W-40 or 20W-50), synthetic oils, low quality oils or oils that contain solid additives are specifically not recommended.

The chart below is a guide to crankcase oil selection. The oil filter should always be changed when changing engine oil.

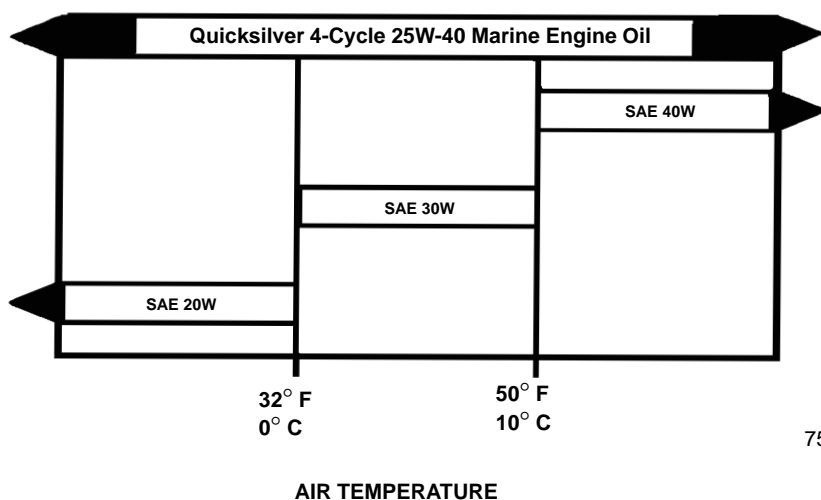

Engine Specifications

Models	5.7L	350 Mag MPI
Propshaft Horsepower (SAV1 Rating)	260 ¹	300 ¹ (290 ²)
Propshaft Kilowatts (SAV1 Rating)	194 ¹	224 ¹ (216 ²)
Displacement	350 cid (5.7L)	
Maximum rpm @ WOT ³	4200-4600 rpm	4400-4800 rpm
Idle rpm in NEUTRAL (Models with SAV1 Emissions Kit) ³	650 RPM ⁵	600 RPM ⁶
Oil Pressure @ 2000 rpm	30-70 psi (207-483 kPa)	
Min. Oil Pressure @ Idle	4 psi (28 kPa)	
Thermostat	160° F (71° C)	
Timing @ Idle rpm ⁴	10° BTDC	8° BTDC
Firing Order	1-8-4-3-6-5-7-2	
Electrical System	12-Volt Negative (-) Ground	
Alternator Rating	65 Amps	65 Amps
Recommended Battery Rating	Min. 375 cca / 475 mca / 90 Ah	Min. 550 cca / 700 mca / 120 Ah

¹ Power Rated in Accordance with NMMA (National Marine Manufacturers' Association) rating procedures.

² Power Rated in Accordance with SAV1 rating procedures. This rating procedure is used to certify that the engine complies with "Stage 1" Bodensee and Swiss Regulations. Horsepower differences shown result from differences in test rpm, allowable test tolerances, and/or installation of special kit components.

³ Measured using an accurate service tachometer, with engine at normal operating temperature.

⁴ A special procedure must be followed to check or adjust timing. Consult your Authorized Mercury MerCruiser Dealer before attempting this procedure.

⁵ A special procedure must be followed to adjust idle rpm. Consult your Authorized Mercury MerCruiser Dealer before attempting this procedure.

⁶ Idle speed on EFI models is not adjustable.

Engine Specifications

Models	7.4L MPI	8.2L MPI
Propshaft HorsePower (SAV1 Rating)	310 ¹ (300 ²)	400 ¹
Propshaft Kilowatts (SAV1 Rating)	231 ¹ (224 ²)	298 ¹
Displacement	454 cid (7.4L)	502 cid (8.2L)
Maximum rpm @ WOT ³	4000-4400 RPM ³	4400-4800 RPM ³
Idle rpm in NEUTRAL ³	600 rpm ⁶	
Oil Pressure @ 2000 rpm	30-70 psi (207-414 kPa)	
Min. Oil Pressure @ Idle	4 psi (28 kPa)	
Thermostat	160° F (71° C)	
Timing @ Idle rpm	8° BTDC ⁴	
Firing Order	1-8-4-3-6-5-7-2	
Electrical System	12-Volt Negative (-) Ground	
Alternator Rating	65 Amps ⁷	
Recommended Battery Rating	Min. 650 cca / 825 mca / 180 Ah	

¹ Power Rated in Accordance with NMMA (National Marine Manufacturers' Association) rating procedures.

² Power Rated in Accordance with SAV1 rating procedures. This rating procedure is used to certify that the engine complies with "Stage 1" Bodensee and Swiss Regulations. Horsepower differences shown result from differences in test rpm, allowable test tolerances, and/or installation of special kit components.

³ Measured using an accurate service tachometer, with engine at normal operating temperature.

⁴ A special procedure must be followed to check or adjust timing. Consult your Authorized Mercury MerCruiser Dealer before attempting this procedure.

⁵ A special procedure must be followed to adjust idle rpm. Consult your Authorized Mercury MerCruiser Dealer before attempting this procedure.

⁶ Idle speed on EFI models is not adjustable.

⁷ Some models may be equipped with a higher rated alternator. See your authorized Mercury MerCruiser Dealer for service.

Maintenance

⚠ WARNING

Always disconnect battery cables from battery before working around electrical system components to prevent injury to yourself or damage to electrical system.

IMPORTANT: Refer to MAINTENANCE CHART for complete listing of all scheduled maintenance to be performed. Some listings can be done by owner/operator, while others should be performed by an Authorized MerCruiser Dealer. Before attempting maintenance or repair procedures not covered in this manual, it is recommended that a MerCruiser Maintenance Procedures Manual or Service Manual be purchased and read thoroughly.

NOTE: Maintenance points are color coded for ease of identification. See the decal on engine for identification.

Maintenance Aids

- 1 Transmission - Dexron III Transmission Fluid.
- 2 Crankcase Oil - Quicksilver 4-Cycle Marine Engine Oil. (Refer to SPECIFICATIONS for alternatives and oil recommendations for varying ambient temperatures.)
- 3 All Exterior Surfaces - Quicksilver Primer and Spray Paint and Quicksilver Corrosion Guard.
- 4 Closed Cooling System Coolant - Extended Life Ethylene Glycol 5/100 Antifreeze/Coolant mixed 50/50 with purified water. If this is not available, use a 50/50 mixture of ethylene glycol antifreeze and tap water. Areas where temperatures generally do not go below 32° F (0° C), rust inhibitor and tap water is acceptable.

CC857

- 5 Walter RV 36 V-drive - SAE 30W Engine Oil.

NOTE: If engine is equipped with a Walter V-Drive, the transmission level should also be checked on the Velvet Drive Transmission. It is also important to note that the two units use a different type of fluid. Refer to "Maintenance Aids" section found earlier in this manual for fluid specifications.

CC917

IMPORTANT: This manual contains basic Operation, Maintenance and Warranty information for your MerCruiser power package. If you desire to perform some of the maintenance items on your own, you should obtain a copy of the Service Manual for your particular power package. Information for obtaining this manual is located at the back of this manual.

CC923

Gas Inboard

Routine Maintenance *	Each Day Start	Each Day End	Weekly	Every Two Months
Check crankcase oil (interval can be extended based on experience).	•			
If operating in salt, brackish or polluted waters, flush cooling system after each use.		•		
Check transmission fluid.			•	
Check water pickups for debris or marine growth. Check water strainer and clean. Check coolant level.			•	

* Only perform maintenance which applies to your particular power package

Gas Inboard(Continued)

Scheduled Maintenance *									
	Annually	Every 100 hours or Annually ◆	Every 200 hours or 3 years ◆	Every 300 hours or 3 years ◆	Every 2 years	Every 5 years	Every 500 hours or 5 years ◆	Every 1000 hours or 5 years ◆	Per OEM
Touch-up paint power package and spray with corrosion guard.	•								
Change crankcase oil and filter.		•							
Change transmission fluid.		•							
Replace fuel filter(s).		•							
Check steering system and remote control for loose, missing or damaged parts. Lubricate cables and linkages.		•							
Retorque engine mounts.		•							
Check spark plugs, wires, distributor cap and ignition timing. Check and adjust idle speed.		•							
Clean flame arrestor and crankcase ventilation hoses. Replace PCV valve.		•							
Check electrical system for loose, damaged or corroded fasteners.		•							
Inspect condition and tension of belts.		•							
Check cooling system and exhaust system hose clamps for tightness. Inspect both systems for damage or leaks.		•							
Disassemble and inspect seawater pump and replace worn components.		•							
Clean seawater section of closed cooling system. Clean, inspect and test pressure cap.		•							
Replace coolant.					•	♠			
Check engine-to-propeller shaft alignment.									•

* Only perform maintenance which applies to your particular power package

◆ Whichever Occurs First

♠ Interval Can Be Used On Any Model By Using Extended Life Coolant

THIS PAGE IS INTENTIONALLY BLANK

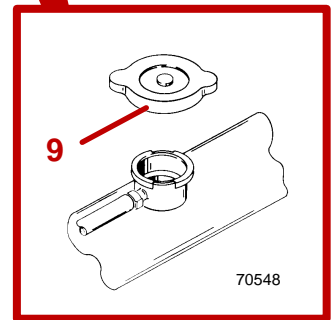
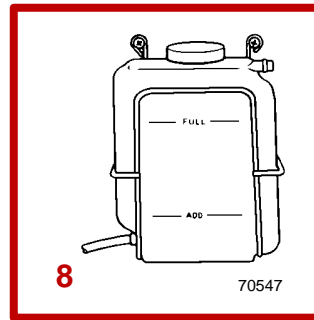
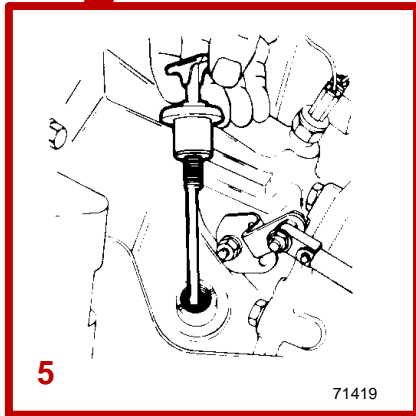
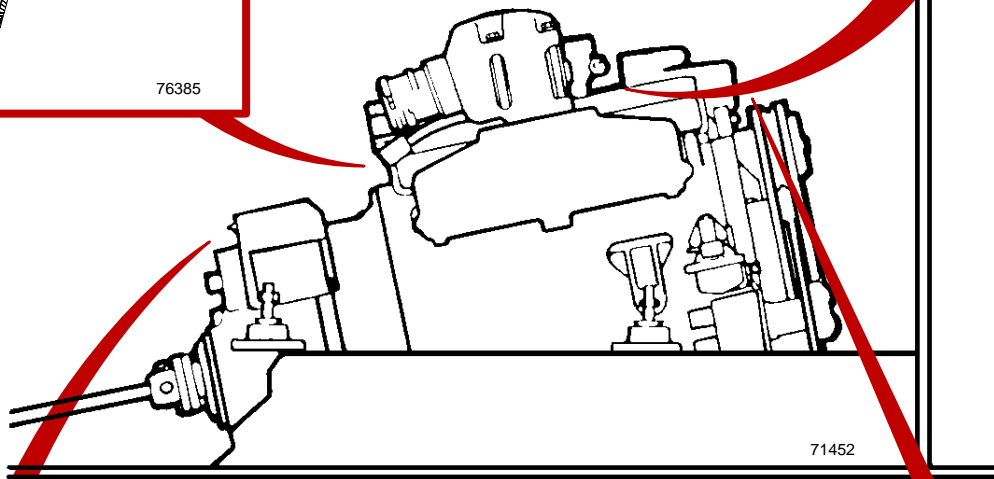
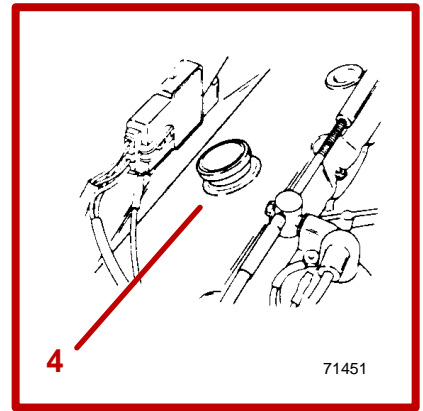
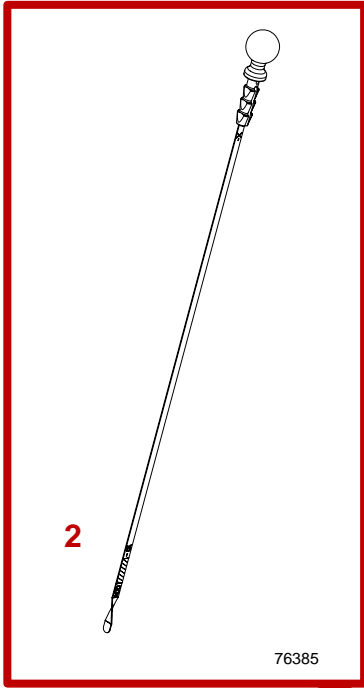

Checking Fluid Levels

CHECKING CRANKCASE OIL

NOTE: 8.2L : ENGINE CRANKCASE OIL MUST BE CHECKED AT INTERVALS SPECIFIED IN “MAINTENANCE CHART.” It is normal for an engine to use a certain amount of oil in the process of lubricating and cooling the engine. Oil consumption will be higher on the 8.2L. This engine uses forged (rather than cast) aluminum pistons to withstand the higher stresses created by its higher horsepower output. The forged pistons require increased piston-to-cylinder bore clearance to accommodate their higher thermo-expansion rate and thus, it is normal for some oil to get past the piston rings and be burnt-up in the combustion chambers. The amount of oil consumption is greatly dependent upon engine speed, with consumption being highest at wide-open-throttle and decreasing substantially as engine speed is reduced.

- 1 Stop engine. Allow approximately five minutes for oil to drain into oil pan. Boat must be at rest in water.
- 2 Remove dipstick. Wipe clean and reinstall fully into dipstick tube.
- 3 Remove dipstick and observe oil level. Oil level must be between FULL or OK and ADD. If oil level is below ADD:
- 4 Remove oil filler cap. Add specified oil to bring level up to, but not over, FULL or OK mark on dipstick.

IMPORTANT: Do not overfill crankcase oil.

CHECKING TRANSMISSION FLUID

IMPORTANT: Engine must be run at 1500 RPM for 2 minutes immediately prior to checking level.

- 5 Velvet Drive Transmissions – Stop engine and quickly check fluid level by turning T-handle counterclockwise, to remove dipstick. Fluid level should be up to full mark. If low, add specified fluid through dipstick tube on transmissions.

CC814

- 6 Hurth Transmissions - Stop engine and remove dipstick to check level. If fluid is below top (full) line, add specified fluid through dipstick hole. Do not overfill. Reinstall dipstick with cap fully seated.

CC858

- 7 Walter V-Drive Transmissions - Stop engine and remove dipstick to check level. If fluid is below top (full) line, add specified fluid through breather elbow. Do not overfill. Reinstall dipstick with cap fully seated.

CA477

CHECKING ENGINE COOLANT - CLOSED COOLED MODELS ONLY

WARNING

Avoid serious injury from burns. Do not remove coolant cap when engine is hot. Coolant may discharge violently.

- 8 Check coolant level in coolant recovery bottle. Add specified coolant as required.
- 9 Periodically remove cap from coolant reservoir to ensure that coolant recovery system is functioning properly. Coolant level must be at top of reservoir filler neck. If coolant is low, inspect gasket in cap for damage and replace if necessary. To have cap tested, contact your Authorized MerCruiser Dealer. Inspect coolant recovery system for leaks.

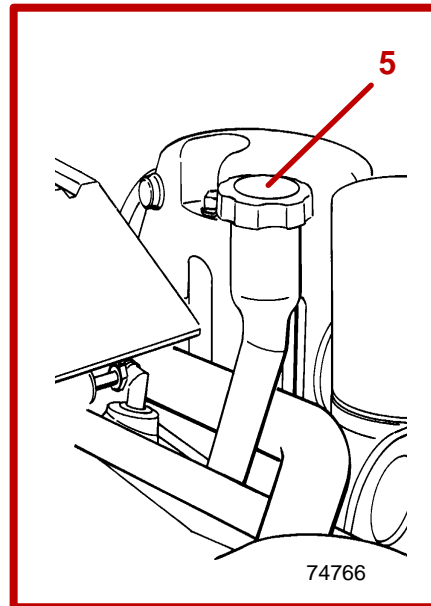
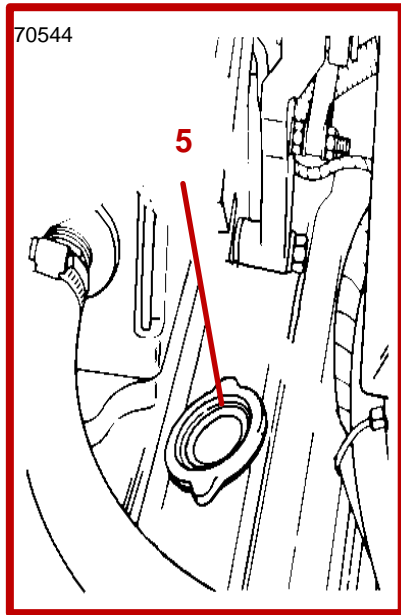
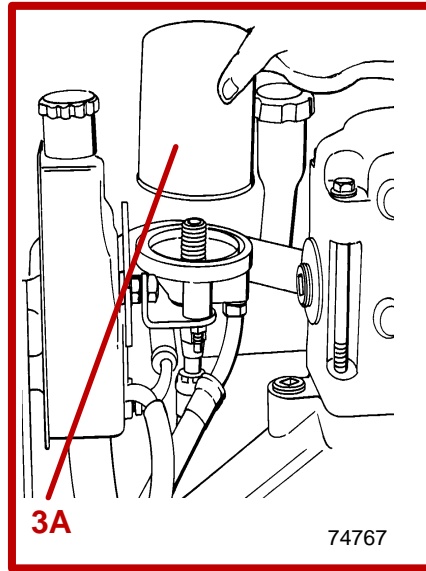
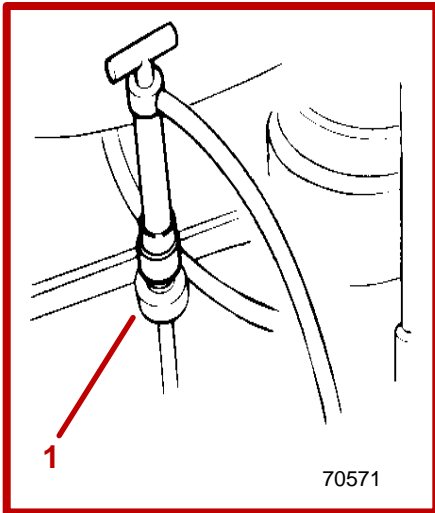

Changing Fluids

See MAINTENANCE SCHEDULE for lubricant change frequency. Lubricant should be changed before placing boat in storage.

Power Trim or Power Steering fluids do not require changing.

Changing Crankcase Oil and Filter

IMPORTANT: Change oil when engine is warm from operation. Warm oil flows more freely, carrying away more impurities. Use only recommended motor oil (see SPECIFICATIONS).

- 1 With engine at normal operating temperature, remove dipstick. Install Quicksilver Crankcase Oil Pump onto dipstick tube.
- 2 Insert hose end of crankcase oil pump into an appropriate container and using pump handle, pump until crankcase is empty. Remove crankcase oil pump.

NOTE: *Alternately the oil may be drained using the oil drain plug and a suitable container placed under the engine. Tighten the oil pan drain plug securely upon installation.*

- 3 Remove and discard old oil filter and old sealing ring.
 - A Models with remote oil filter.
 - B Models with side mounted oil filter.
- 4 Coat sealing ring on new filter with motor oil. Install new filter. Tighten filter securely. Hand tighten only, do not use a filter wrench. Do not overtighten.
- 5 Remove oil filler cap. Add correct type oil (see SPECIFICATIONS) to bring level up to, but not over FULL or OK mark on dipstick.

IMPORTANT: Always use dipstick to determine exactly how much oil is required.

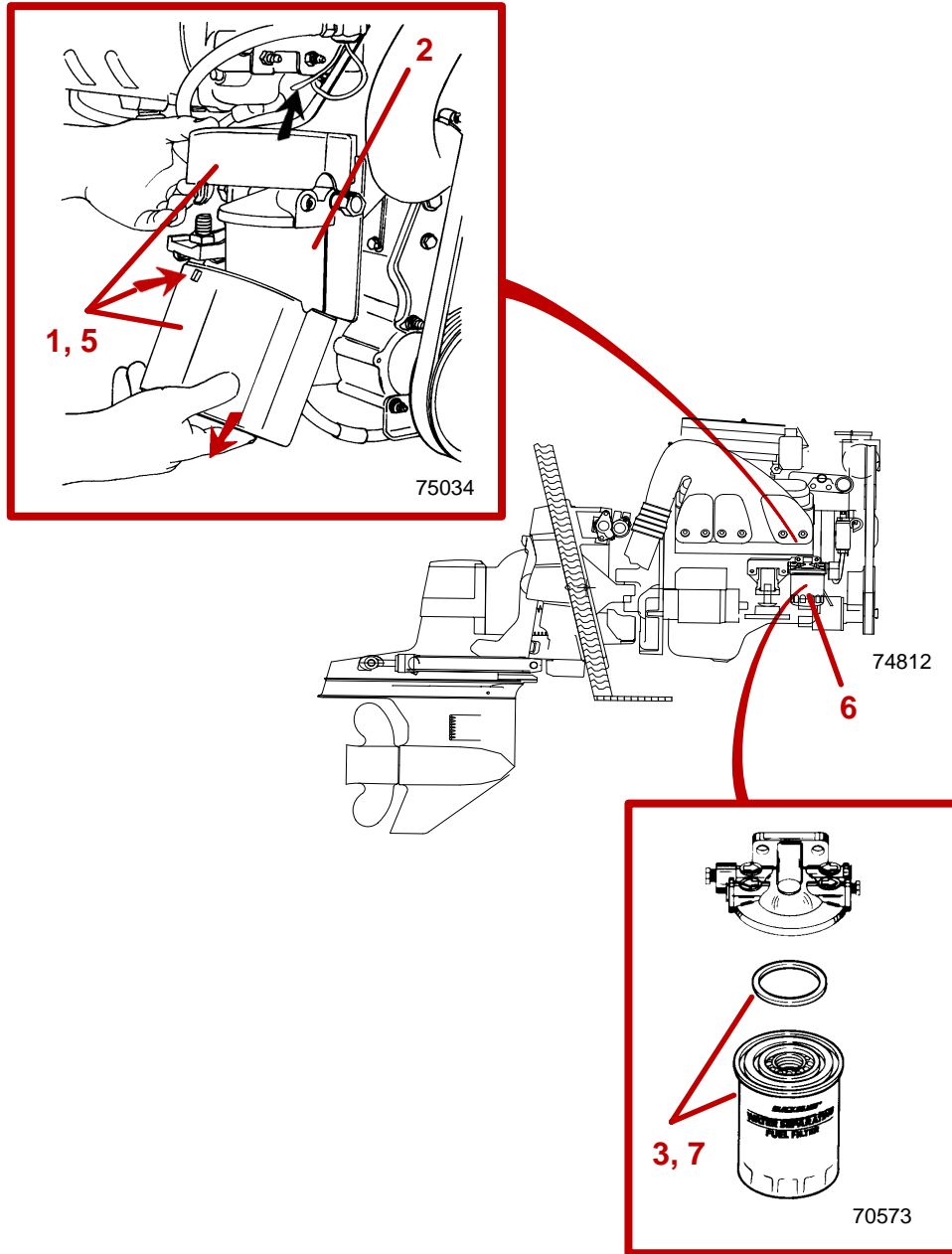

Changing Water Separating Fuel Filter

⚠ WARNING

Be careful when changing water separating fuel filter. Gasoline is extremely flammable and highly explosive under certain conditions. Be sure ignition key is OFF. Do not smoke or allow spark or open flame in area when changing fuel filter. Wipe up any spilled fuel immediately.

⚠ WARNING

Make sure no fuel leaks exist before closing engine hatch.

EFI Models

⚠ CAUTION

The electric fuel pump and factory installed water separating fuel filter have been carefully designed to function properly together. Do not install additional fuel filters and/or water separating fuel filters between fuel tank and engine.

The installation of additional filters may cause:

- Fuel Vapor Locking
- Difficult Warm-Starting
- Piston Detonation Due to Lean Fuel Mixture
- Poor Driveability

1 Unsnap latch and slide top and bottom cover pieces from around the water separating fuel filter and bracket.

NOTE: Top and bottom cover pieces are formed with a groove on each side that slides around the brackets outer edges.

2 Remove water separating fuel filter and sealing ring from mounting bracket and discard.

3 Coat sealing ring on new filter with motor oil. Thread filter onto bracket and tighten securely by hand. Do not use a filter wrench.

4 Start and run engine. Check filter connection for gasoline leaks. If leaks exist, recheck filter installation. If leaks continue, stop engine immediately and contact your Authorized MerCruiser Dealer.

5 Install cover pieces around fuel filter. Be certain top part of cover latches to lower part.

CA659

Carbureted Models

6 Remove water separating fuel filter and sealing ring from mounting bracket and discard.

7 Coat sealing ring on new filter with motor oil. Thread filter onto bracket and tighten securely by hand. Do not use a filter wrench.

8 Start and run engine. Check filter connection for gasoline leaks. If leaks exist recheck filter installation. If leaks continue stop engine immediately and contact your Authorized MerCruiser Dealer.

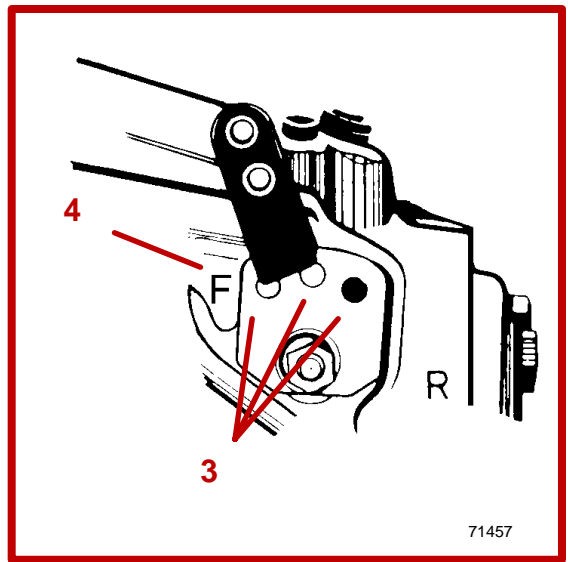
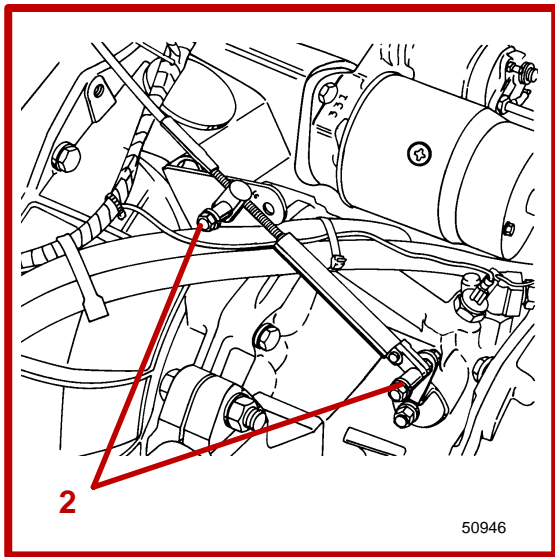
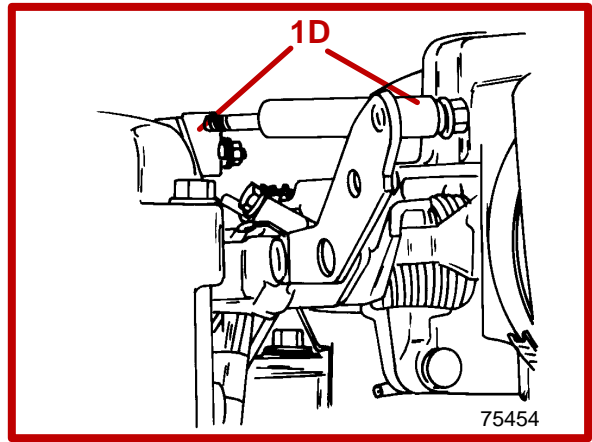
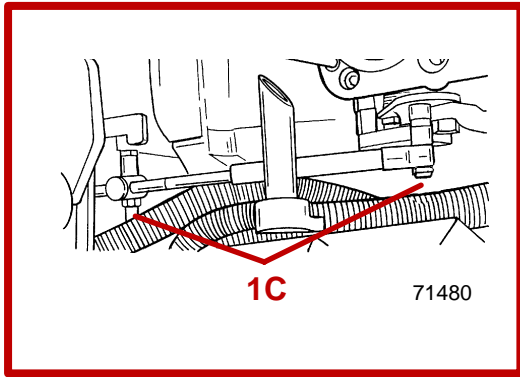
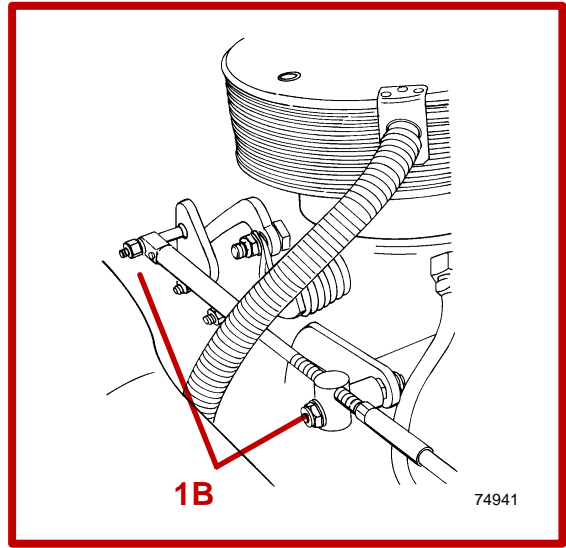
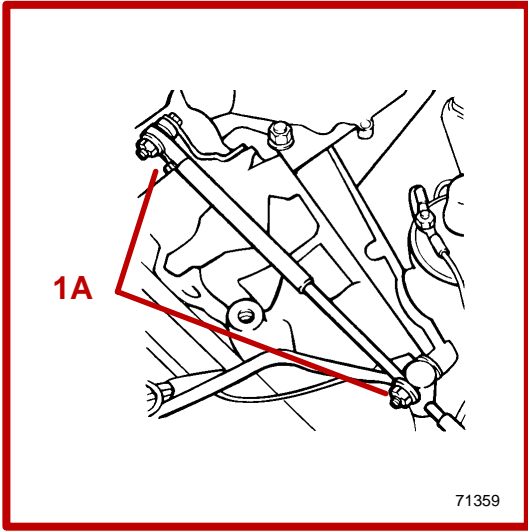

Lubrication

Throttle Cable

- 1 Lubricate pivot points with SAE 30W motor oil.
 - A Carbureted Models
 - B EFI Models
 - C 350 Magnum MPI Models
 - D 454 Magnum MPI Models

CC714

Shift Cable

- 2 Lubricate pivot points with SAE 30W motor oil.
- 3 Lubricate poppet ball and holes in lever with SAE 30W motor oil.

IMPORTANT: Poppet Ball MUST BE centered in detent hole for each F-N-R position.

- 4 Shift lever must be over this letter when propelling boat FORWARD. This does not apply to Velvet Drive Down-Angle Transmission. On this transmission, the shift lever will be positioned aft (rear) for “Forward Gear - Right Hand Rotation Propeller” and will be positioned forward (front) for “Forward Gear - Left Hand Rotation Propeller”.

IMPORTANT: Remote control shift cable and linkages must position transmission shift lever so that it is fully in the FORWARD and REVERSE gear detent positions with the lever over the letter “F” on transmission case when propelling boat forward. There are no letters “F or R” on Velvet Drive Down-Angle and V-Drive Transmissions. IMPROPER POSITIONING OF SHIFT LEVER MAY CAUSE TRANSMISSION TO FAIL. Damage caused to transmission as a result of improper shift lever positioning will not be covered by Velvet Drive Transmission Warranty.

To obtain service and/or parts literature for your Velvet Drive transmission, contact:

Velvet Drive
 Marine and Industrial Transmissions
 Theodore Rice Boulevard
 Industrial Park
 New Bedford, MA 02745 U.S.A.

CC846

To obtain service and/or parts literature for your Hurth transmission, contact:

Mercury Marine
 Publications Department
 P.O. Box 1939
 Fond du Lac, WI 54936-1939

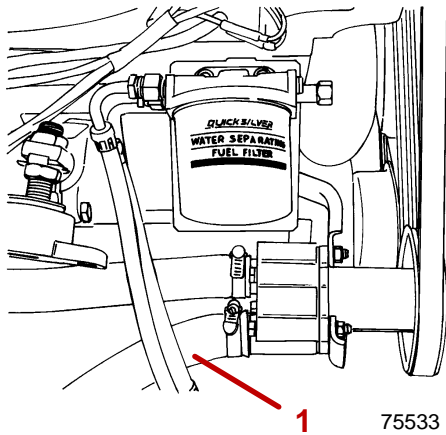

75533

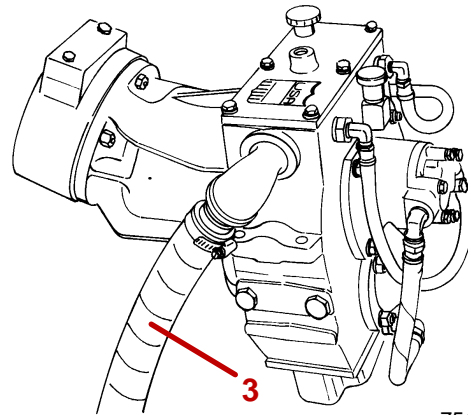

75191

Flushing Cooling System

⚠ WARNING

When flushing, be certain the area around propeller is clear, and no one is standing nearby. To avoid possible injury, remove propeller.

⚠ CAUTION

Do not run engine above 1500 rpm when flushing. Suction created by seawater pickup pump may collapse flushing hose, causing engine to overheat.

⚠ CAUTION

Watch temperature gauge on dash to ensure that engine does not overheat.

⚠ CAUTION

If cooling system is to be flushed with boat in the water, water inlet valve (if so equipped) must be closed, or water inlet hose must be disconnected and plugged to prevent water from flowing into boat.

⚠ CAUTION

If boat is in the water, do not open water inlet valve until engine is to be restarted, to prevent contaminated water from flowing back into engine.

NOTE: To prevent silt and/or salt buildup in cooling system, flush with freshwater at specified intervals.

- 1** If boat is equipped with a circulating pump hose flush device, attach water hose to flush device on circulating pump hose.
- 2** If boat is not equipped with a circulating pump hose flush device, disconnect water inlet hose (lower hose) from aft end of seawater pickup pump. Using appropriate connector, connect hose between connector and water tap.
- 3 Models with Walter V-Drive Transmissions:** Disconnect water inlet hose from transmission fitting.
- 4** Partially open water tap (about 1/2 maximum).
- 5** Place remote control in NEUTRAL, idle speed position, and start engine. Operate engine at idle speed, in NEUTRAL, for about 10 minutes or until discharge water is clear.
- 6** Stop engine. Shut off water, remove flushing connector from pump inlet and reconnect water inlet hose. Tighten hose clamp securely.
- 7** Attach water hose to flush device on circulating pump hose.
- 8** Partially open water tap (about 1/2 maximum).
- 9** Do NOT start engine. Allow water to run for approximately 5 minutes. Shut off water and remove water hose from flush device.

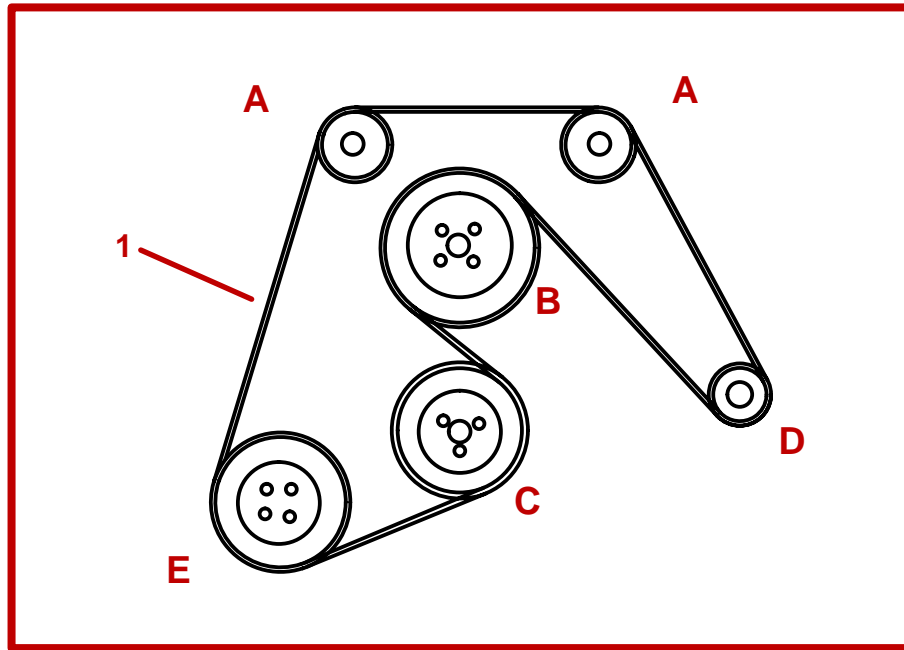

CC908

Serpentine Drive Belt

⚠ WARNING

Avoid injury caused by hands or clothing being caught between belts and pulleys. Make sure engine is shut off and ignition key is removed before inspecting belts.

Belt must be periodically inspected for condition and tension.

NOTE: Belt deflection is to be measured on the belt at the location that has the longest distance between two pulleys. Normally this location is between the seawater and belt adjustment idler pulleys.

1 Check the tension of the serpentine drive belt. If there is more than 1/4 in. deflection, see your Authorized MerCruiser Dealer to have the tension adjusted.

2 5.7L and 350 Mag MPI

3 7.4L MPI and 8.2L MPI

If any drive belt needs replacement or tension needs adjustment, see your Authorized MerCruiser Dealer.

A Idler Pulley

B Circulating Pump Pulley

C Crankshaft Pulley

D Alternator Pulley

E Seawater Pump Pulley

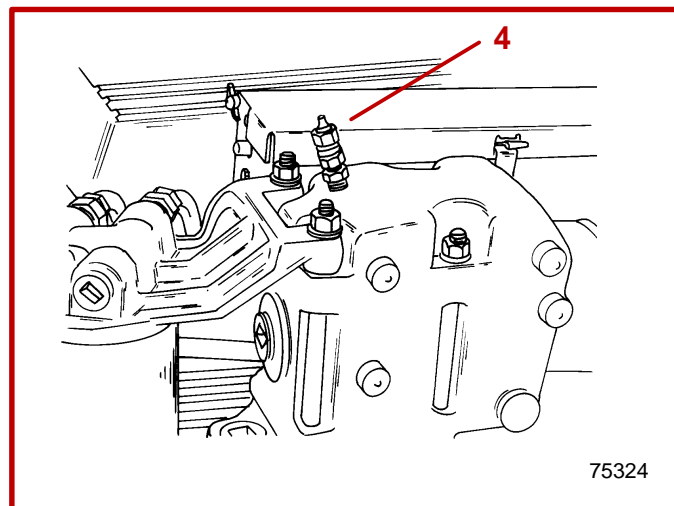
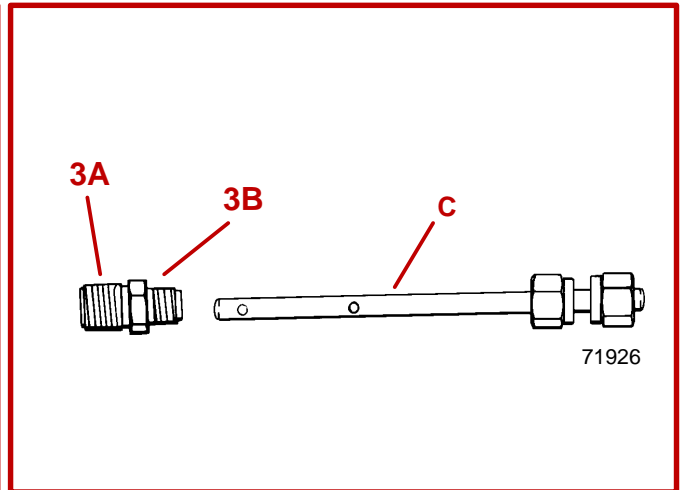
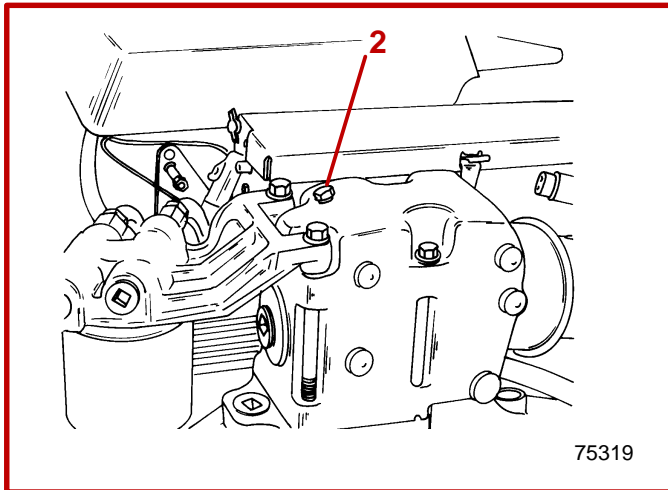
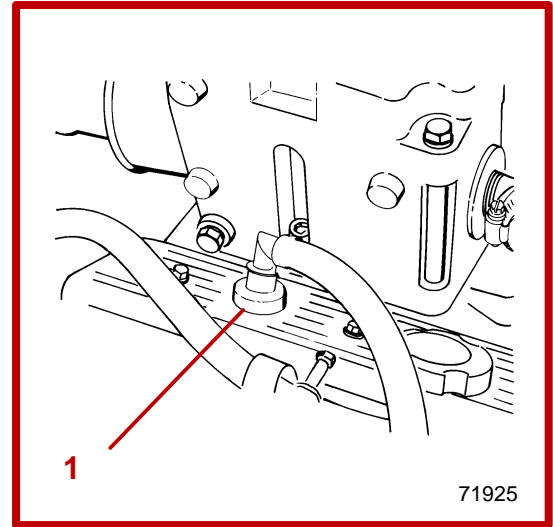
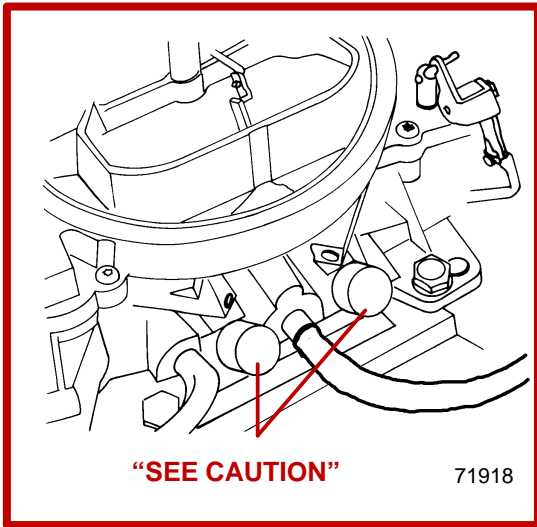

Emissions (Europe Only)

CA399

The following information applies only to engines with a special emissions kit installed. If the kit has been installed, your engine complies with “Stage 1” Bodensee and Swiss Regulations.

CA398

Sealed Carburetor Mixture Screws

The carburetor on this engine has seals on the carburetor mixture screws. These seals prevent adjustment of the fuel mixture settings.

CAUTION

Do not remove mixture screw seals and/or attempt to adjust fuel mixture setting. Tampering with the mixture setting on this engine could affect the exhaust emissions level, thus voiding the emissions certification. These seals should only be removed by an authorized dealer or emissions testing agency.

CA99

Changing Positive Crankcase Ventilation Valve (PCV)

This engine is equipped with a positive crankcase ventilation valve (PCV). This valve should be changed every 100 hours of operation or at least once a year, whichever occurs first.

1 Remove PCV valve from port valve cover. Disconnect it from the hose and discard valve. Install new PCV valve in valve cover and reconnect hose. Ensure valve is tightly seated in valve cover.

CA100

Emissions Testing

Your engine is equipped with special design features and special tuning to minimize the emission output from the engine. You should follow:

- Recommended maintenance schedules particularly as to the ignition system.
- Proper engine tuning procedures to ensure these features remain in good operating order.
- Proper steps to maintain the engine within specifications.

Use only MerCruiser replacement parts to ensure compliance with emission regulations.

CA638

Installing Test Probes

IMPORTANT: The testing dealer or agency will be equipped with the appropriate test equipment and adapters for this engine. The test probes should be installed as follows:

- 2** Remove plugs from both exhaust elbows.
- 3** Install exhaust elbow adapter fittings as follows.
 - A** Apply Loctite Pipe Sealant with Teflon to threads that go into elbow.
 - B** Install fittings into elbows. Tighten fittings securely.
- 4** Insert exhaust probes (**C**) into fittings and tighten securely.

The testing agency will connect their adapters and test equipment to the probes to conduct the test. Once the test is complete, they should remove the test probes and fittings, apply Quicksilver Perfect Seal to the threads of both plugs and reinstall them into elbows.

Miscellaneous Maintenance

Battery

All lead acid batteries discharge when not in use. Recharge every 30 to 45 days, or when specific gravity drops below battery manufacturer's specifications.

Refer to specific instructions and warnings accompanying your battery. If this information is not available, observe the following precautions when handling a battery.

WARNING

Avoid serious injury from gasoline fire or explosion. Do not use jumper cables and a booster battery to start engine. Do not recharge a weak battery in the boat. Remove battery and recharge in a ventilated area away from fuel vapors, sparks or flames.

WARNING

Batteries contain acid which can cause severe burns-Avoid contact with skin, eyes and clothing. Batteries also produce hydrogen and oxygen gases when being charged. This explosive gas escapes fill/vent cell caps and may form an explosive atmosphere around the battery for several hours after it has been charged. Sparks or flames can ignite the gas and cause an explosion which may shatter the battery and could cause blindness or other serious injury.

Safety glasses and rubber gloves are recommended when handling batteries or filling with electrolyte. Hydrogen gases that escape from the battery during charging are explosive. When charging batteries, be sure battery compartment or area where batteries are located, is well-vented. Battery electrolyte is a corrosive acid and should be handled with care. If electrolyte is spilled or splashed on any part of the body, immediately flush the exposed area with liberal amounts of water and obtain medical aid as soon as possible.

CA104

Bottom Of Boat

To maintain maximum speed, the following conditions of the boat bottom should be observed:

- Clean, free of barnacles and marine growth.
- Free of distortion, nearly flat where it contacts water.
- Straight and smooth, fore and aft.

CA105

Inspection And Maintenance

Inspect power package often, and at regular intervals, to help maintain its top operating performance, and correct potential problems before they occur. The entire power package should be checked carefully, including all accessible engine parts.

Check for loose, damaged or missing parts, hoses and clamps; tighten or replace as required.

Check plug leads and electrical leads for damage.

Remove and inspect propeller. If badly nicked, bent or cracked, see your dealer.

Repair nicks and corrosion damage on power package exterior finish. Use Quicksilver spray paints - see your Authorized MerCruiser Dealer.

THIS PAGE IS INTENTIONALLY BLANK

Cold Weather Or Extended Storage

Power Package Lay Up

ALL MODELS

IMPORTANT: MerCruiser strongly recommends that this service should be performed by an Authorized MerCruiser Dealer. Damage caused by freezing IS NOT covered by the MerCruiser Limited Warranty.

WARNING

Be sure engine compartment is well ventilated and no gasoline vapors are present during the following operation to prevent a potential fire hazard.

WARNING

BE CAREFUL while working on fuel system; gasoline is extremely flammable and highly explosive under certain conditions. Be sure that ignition key is OFF and do not smoke or allow sources of spark and/or open flames in the area.

CAUTION

DO NOT operate engine without water flowing through seawater pickup pump, as pump impeller may be damaged and subsequent overheating damage to engine may result.

IMPORTANT: Before starting engine, a water source must be attached to the seawater pickup pump. Follow all warnings and flushing attachments procedures stated, in “FLUSHING COOLING SYSTEM.”

- 1 Follow instructions “a” or “b” depending on type of fuel available during layup:
 - A If boat is to be placed in storage with fuel in fuel tanks that does not contain alcohol:** Fill fuel tank(s) with fresh gasoline that does not contain alcohol and a sufficient amount of Quicksilver Gasoline Stabilizer for Marine Engines to treat the gasoline. Follow instructions on container.
 - B If boat is to be placed in storage with fuel in fuel tanks that does contain alcohol (if fuel without alcohol is unavailable):** Fuel tanks should be drained as completely as possible and Quicksilver Gasoline Stabilizer for Marine Engines added to any fuel remaining in the tank. Follow instructions on container.

NOTE: If desired, a portable fuel tank can be used to perform the remainder of the power package lay up procedures. Be sure to add an appropriate amount of Gasoline Stabilizer to the portable tank.

- 2 Replace the water separating fuel filter as outlined in “Changing Water Separating Fuel Filter.”
- 3 Supply water to the seawater pickup pump as outlined in “Flushing Cooling System.”
- 4 Start the engine and check for fuel leaks. If leaks exist, stop engine immediately. Recheck filter installation.
- 5 Start the engine. Operate at idle RPM until it reaches normal operating temperature and the fuel stabilizer has been circulated. Shut off the engine.
- 6 Change the engine oil and filter.
- 7 If boat has been operated in salty, polluted or mineral-laden waters, flush cooling system as outlined in “Flushing Cooling System.”
- 8 Proceed to the following instructions appropriate for your model for additional fuel system preparation.

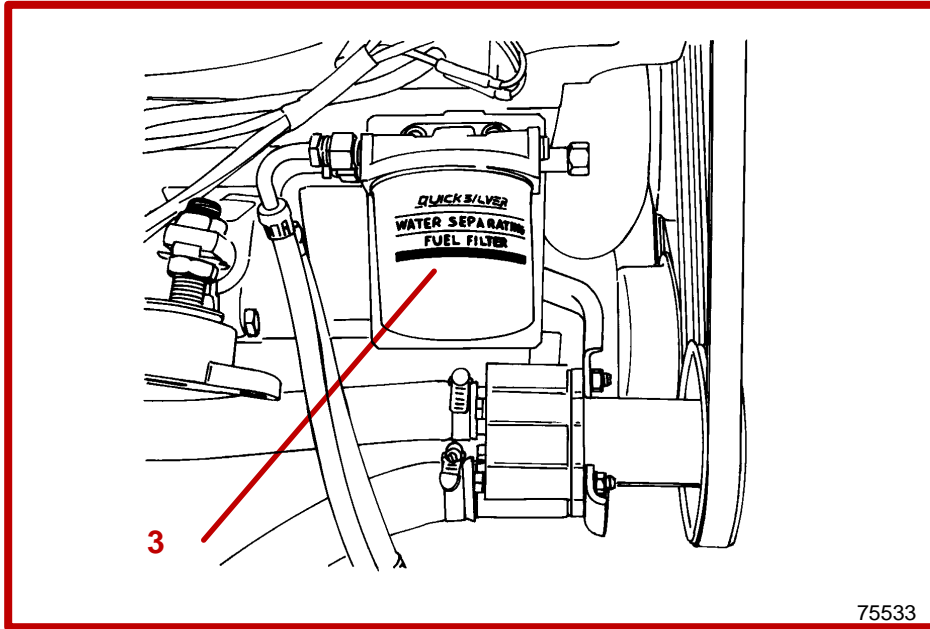

75533

Power Package Lay Up (continued)

EFI MODELS

WARNING

Avoid Fire or Explosion: Be sure engine compartment is well ventilated and no gasoline vapors are present during the following operation.

WARNING

Avoid Fire or Explosion: Fuel injection system is pressurized during operation. Use care when removing water separating fuel filter. Fuel could spray on hot engine causing fire or explosion. Allow engine to cool down before attempting to remove the water separating fuel filter in the following procedure. Also, hold a clean shop towel over the water separating fuel filter when removing it, to help avoid fuel spraying on the engine.

- 1 Close the fuel shut-off valve, if equipped. If no fuel shut-off valve is present, a suitable method must be employed to STOP the flow of fuel from the fuel tank to the engine before proceeding.
- 2 Allow engine to cool down.
- 3 Remove the water separating fuel filter.
- 4 Pour out a small amount of fuel into a suitable container, then add approximately 2 fluid ounces (60 ml) of Quicksilver 2-Cycle Outboard Oil to fuel in the water separating fuel filter.
- 5 Reinstall water separating fuel filter.
- 6 Start the engine and check for fuel leaks. If leaks exist, stop the engine immediately. Recheck filter installation.
- 7 Start and operate engine at idle speed until the water separating fuel filter and fuel injection system are empty and engine stops.
- 8 Refer to "Flushing Cooling System" and appropriately remove water supply to the seawater pickup pump.
- 9 After fuel system preparation, complete the following steps as appropriate for your model:
 - A Clean flame arrestor and crankcase ventilation hoses as outlined in "Cleaning Flame Arrestor and Related Components."
 - B Drain seawater section of cooling system as outlined in "Draining Instructions."
 - C **Closed Cooling System Models:** Test coolant to ensure that it will protect against freezing to the lowest temperature expected during storage.
 - D Lubricate all items outlined in "Lubrication."
 - E Service batteries. Refer to manufacturer's instructions.
 - F Clean outside of engine and repaint any areas required with Quicksilver Primer and Spray Paint. After paint has dried, spray Quicksilver Corrosion Guard or wipe down with Quicksilver Storage Seal or SAE 20W engine oil.

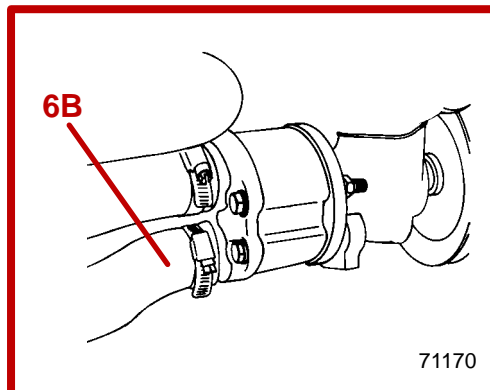
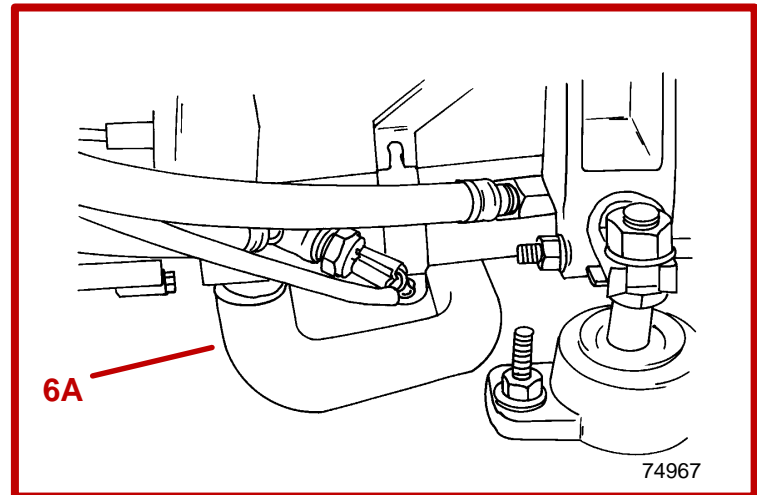
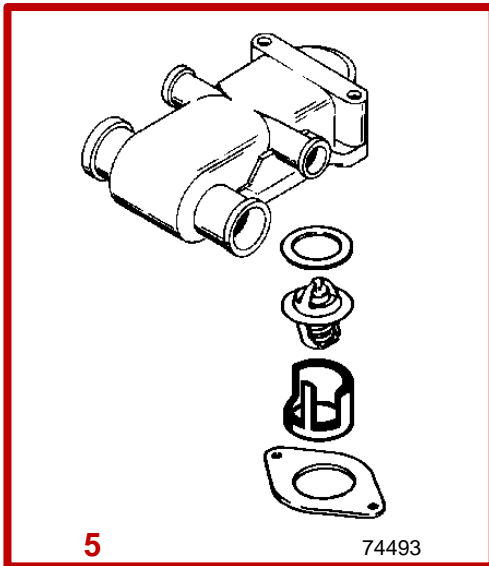
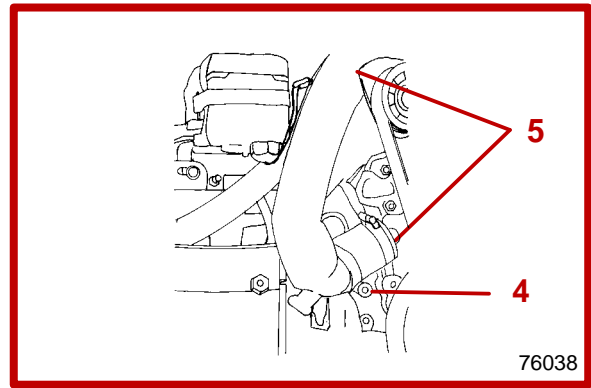
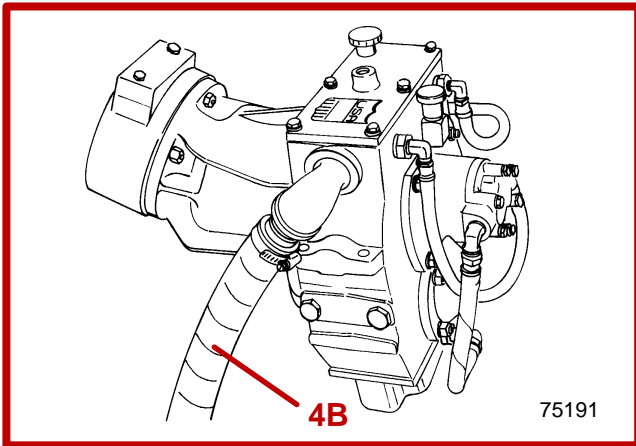
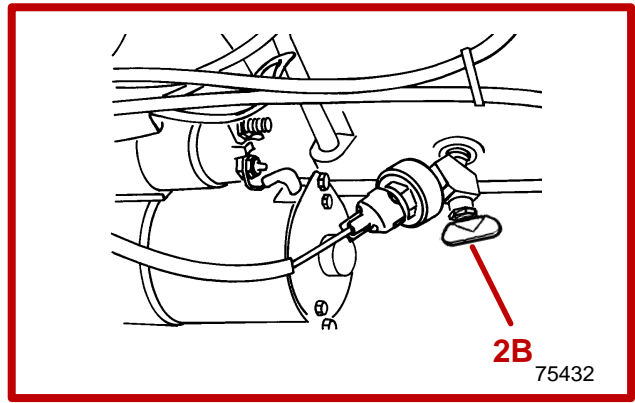
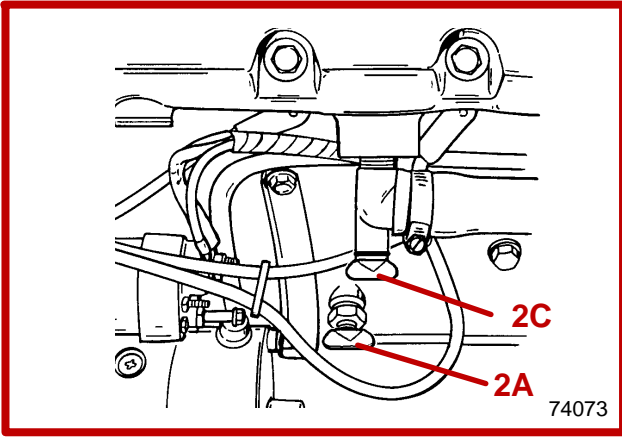

Draining Instructions for Seawater (Raw-Water) Cooled Models

CARBURETED MODELS

⚠ CAUTION

If boat is to remain in water after draining, seawater inlet hose must be removed and plugged to prevent a siphoning action that may occur, allowing seawater to flow from the drain holes or removed hoses.

IMPORTANT: Boat must be as level as possible to ensure complete draining of cooling system.

⚠ CAUTION

Seawater section of cooling system **MUST BE COMPLETELY** drained for winter storage, or immediately after cold weather use, if the possibility of freezing temperatures exist. Failure to comply may result in trapped water causing freeze and/or corrosion damage to engine.

- 1 Ensure engine is as level as possible to ensure complete draining of cooling system.
- 2 Remove drain plugs from following locations:
 - A Port Side - from cylinder block.

⚠ CAUTION

Avoid product damage. Do not disturb the Y-fitting when removing the drain plug. There is an ignition control "Knock Sensor" in the upper hole of the fitting. This sensor must not be loosened or removed. It is tightened to a critical specification at the factory.

- B Starboard Side - from Y-fitting.
 - C Bottom of exhaust manifolds (port and starboard).
 - 3 Repeatedly clean out drain holes using a stiff piece of wire. Do this until entire system is drained.
- NOTE:** It may be necessary to lift or bend hoses to allow water to drain completely. Crank engine over slightly to purge any water trapped in seawater pickup pump. Do not allow engine to start.
- 4 **Models equipped with circulating pump hose drain plug:** Remove drain plug.
 - 5 **Models without circulating pump hose drain plug:** Loosen hose clamps and disconnect hose from thermostat housing or circulating pump. Allow water to drain.
 - 6 Loosen hose clamps and remove the following hoses:
 - A From seawater pickup pump (bottom hose) or from fitting on Walter V-Drive transmission, if equipped.
 - B From transmission cooler.

After cooling system has been drained completely, install drain plugs, reconnect hoses and tighten all hose clamps securely.

IMPORTANT: MerCruiser recommends that propylene glycol (a nontoxic and environmentally safe) antifreeze be used in the seawater section of the cooling system for cold weather or extended storage. Make sure that the propylene glycol antifreeze contains a rust inhibitor and is recommended for use in marine engines. Be certain to follow the propylene glycol manufacturer's recommendations.

- 7 For additional assurance against freezing and rust, remove the thermostat cover and thermostat. Fill the engine seawater cooling system with a mixture of antifreeze and tap water mixed to manufacturer's recommendation to protect engine to the lowest temperature to which it will be exposed during cold weather or extended storage. Using a new gasket, reinstall thermostat and cover. Tighten cover bolts securely.

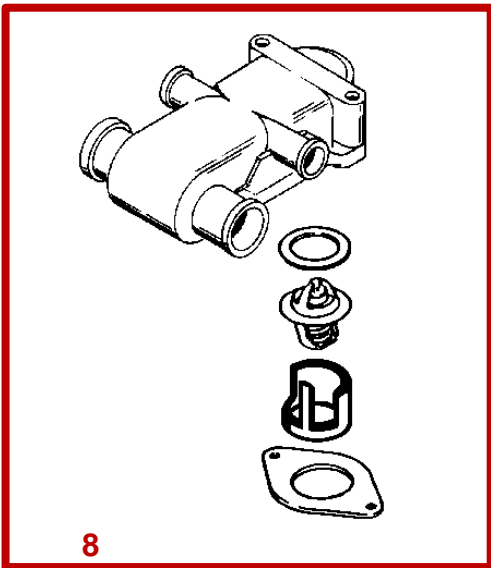
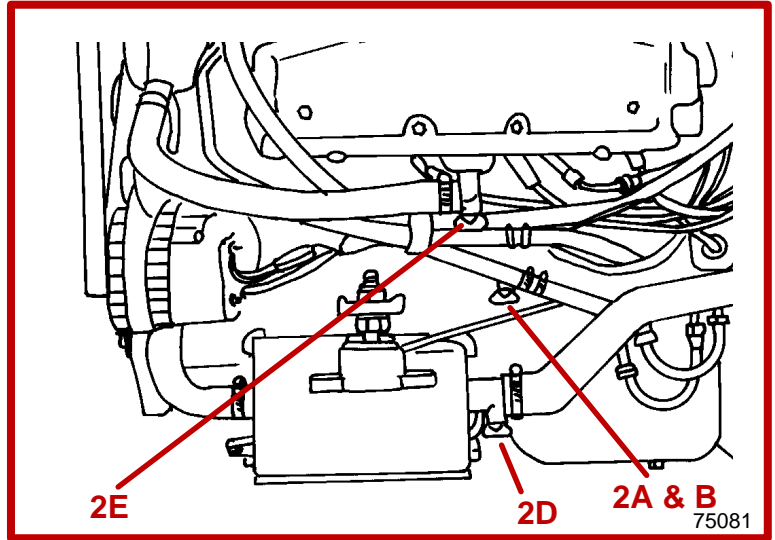
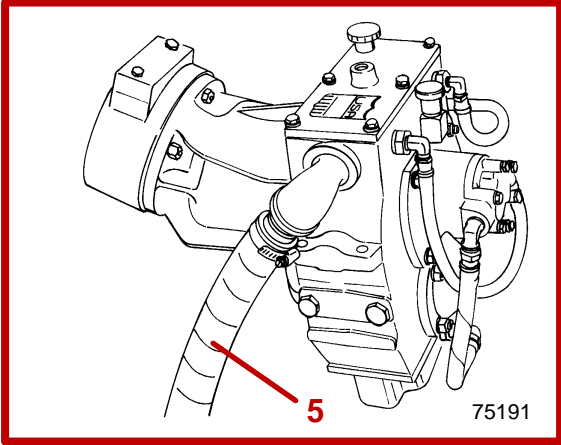
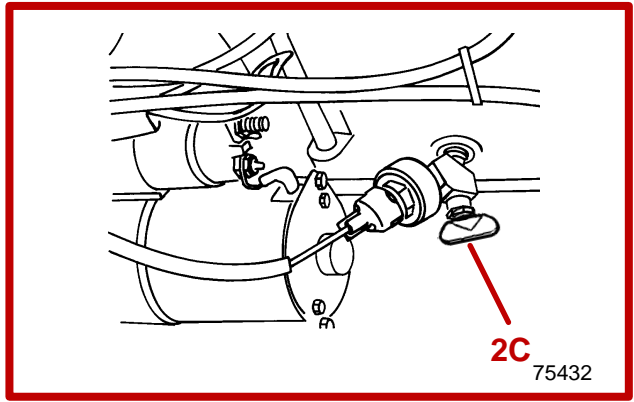
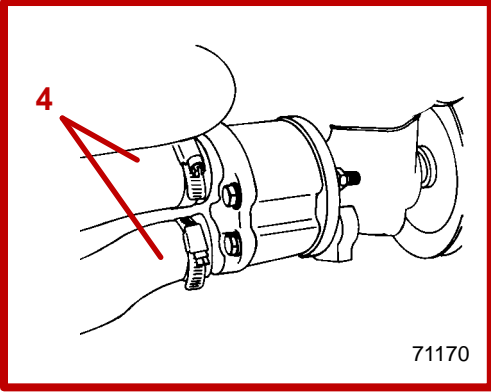

Draining Instructions for Seawater (Raw-Water) Cooled Models (continued)

EFI MODELS

⚠ CAUTION

If boat is to remain in water after draining, seawater inlet hose must be removed and plugged to prevent a siphoning action that may occur, allowing seawater to flow from the drain holes or removed hoses.

IMPORTANT: Boat must be as level as possible to ensure complete draining of cooling system.

⚠ CAUTION

Seawater section of cooling system **MUST BE COMPLETELY** drained for winter storage, or immediately after cold weather use, if the possibility of freezing temperatures exist. Failure to comply may result in trapped water causing freeze and/or corrosion damage to engine.

- 1 Ensure engine is as level as possible to ensure complete draining of cooling system.
- 2 Remove drain plugs from the following locations:
 - A On 454 cid (7.4L) and 502 cid (8.2L) Port and Starboard Side - from cylinder block.
 - B On 350 cid (5.7L) Port Side - from cylinder block.

⚠ CAUTION

Avoid product damage. Do not disturb the Y-fitting when removing the drain plug. There is an ignition control "Knock Sensor" in the upper hole of the fitting. This sensor must not be loosened or removed. It is tightened to a critical specification at the factory.

- C On 350 cid (5.7L) Starboard Side - from Y-fitting.
 - D Fuel cooler.
 - E Bottom of exhaust manifolds (port and starboard).
- 3 Repeatedly clean out drain holes using a stiff piece of wire. Do this until entire system is drained.

NOTE: It may be necessary to lift or bend hoses to allow water to drain completely. Crank engine over slightly to purge any water trapped in seawater pickup pump. Do not allow engine to start.
- 4 Loosen hose clamps and remove both hoses from seawater pump.
- 5 Loosen hose from fitting on Walter V-Drive transmission, if equipped.
- 6 **Models equipped with circulating pump hose drain plug:** Remove drain plug.
- 7 **Models without circulating pump hose drain plug:** Loosen hose clamps and disconnect hose from thermostat housing or circulating pump. Allow water to drain.
- 8 After cooling system has been drained completely, install drain plugs, reconnect hoses and tighten all hose clamps securely.

IMPORTANT: MerCruiser recommends that propylene glycol antifreeze (a nontoxic and environmentally safe) antifreeze be used in seawater section of the cooling system for cold weather or extended storage. Make sure that the propylene glycol antifreeze contains a rust inhibitor and is recommended for use in marine engines. Be certain to follow the propylene glycol manufacturer's recommendations.

- 9 For additional assurance against freezing and rust, remove the thermostat cover and thermostat. Fill the engine seawater cooling system with a mixture of antifreeze and tap water mixed to manufacturer's recommendation to protect engine to the lowest temperature to which it will be exposed during cold weather or extended storage. Using a new gasket, reinstall thermostat and cover. Tighten cover bolts securely.

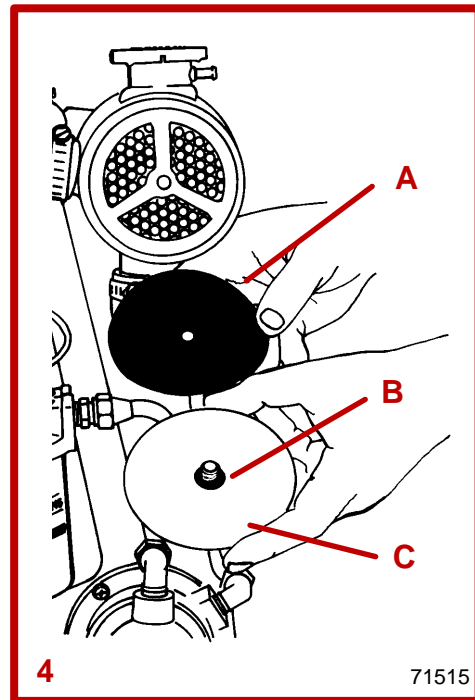
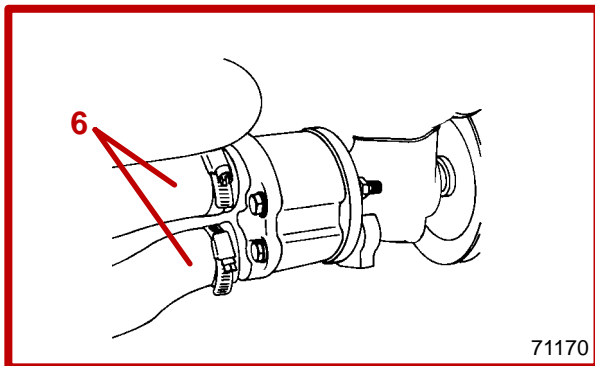
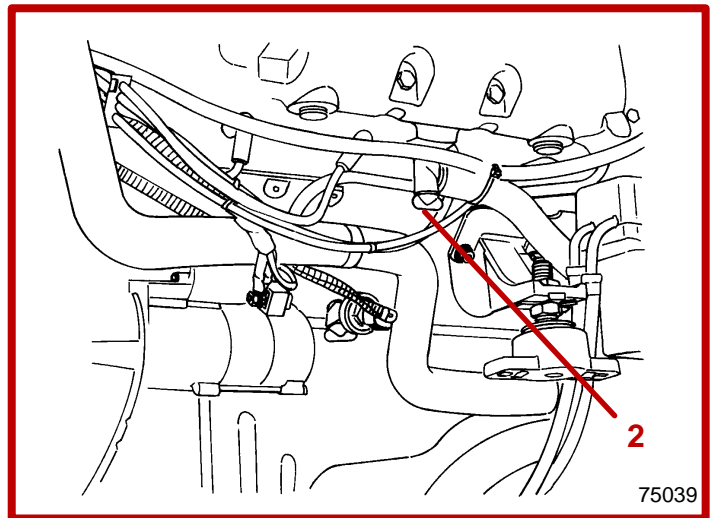
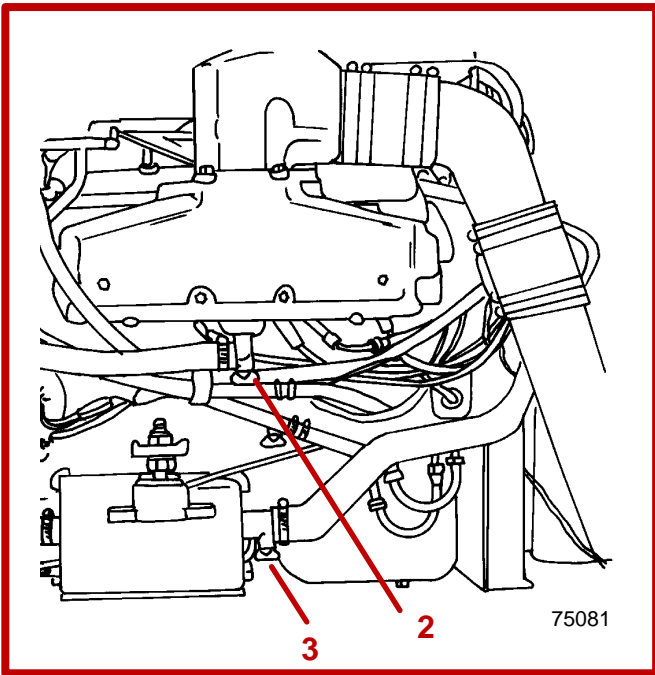

Draining Instructions for Closed Cooled (Coolant) Models

CARBURETED AND EFI MODELS

IMPORTANT: Drain seawater section of closed cooling system only. The coolant should not be drained for cold weather or extended storage.

⚠ CAUTION

If boat is to remain in water after draining, seawater inlet hose must be removed and plugged to prevent a siphoning action that may occur, allowing seawater to flow from the drain holes or removed hoses.

IMPORTANT: Boat must be as level as possible to ensure complete draining of cooling system.

⚠ CAUTION

Seawater section of cooling system **MUST BE COMPLETELY** drained for winter storage, or immediately after cold weather use, if the possibility of freezing temperatures exist. Failure to comply may result in trapped water causing freeze and/or corrosion damage to engine.

IMPORTANT: Closed cooling section must be kept filled year-round with recommended coolant. See "Maintenance Aids" for recommended coolant. If engine will be exposed to freezing temperatures, make sure closed cooling section is filled with an ethylene glycol antifreeze and water solution properly mixed to protect engine to lowest temperature to which it will be exposed.

IMPORTANT: Do not use Propylene Glycol Antifreeze in the closed cooling section of the engine.

- 1 Ensure engine is as level as possible to ensure complete draining of cooling system.
- 2 Remove drain plugs (port and starboard) from bottom of exhaust manifolds.
- 3 Remove drain plug from fuel cooler, if equipped.
- 4 Remove end caps (C), sealing washers (B) and gaskets (A) from the heat exchanger.

IMPORTANT: Use compressed air to blow any remaining water from the tubes in the heat exchanger.

- 5 Repeatedly clean out drain holes using a stiff piece of wire. Do this until entire system is drained.
- 6 Loosen hose clamps and remove both hoses from seawater pickup pump.
- 7 Crank engine over slightly with starter motor to purge any water trapped in seawater pickup pump. **DO NOT** allow engine to start.
- 8 After seawater section of cooling system has been drained completely, reconnect all hoses, reinstall heat exchanger end caps with new gaskets, and reinstall drain plugs.

CA115

Battery Winter Storage

Follow battery manufacturer's instructions for storage.

CA645

Do-It-Yourself Maintenance

If you desire to perform your own maintenance, contact an Authorized MerCruiser Dealer to obtain a "Maintenance Procedures Manual." Refer to the Do-It-Yourself Maintenance Suggestions at the front of the manual for additional information.

CC898

Power Package Recommissioning

WARNING

To prevent possible injury or damage to equipment, do not install battery until all maintenance has been performed on engine.

- 1 Check that all cooling system hoses are connected properly and hose clamps are tight.

CAUTION

When installing battery, be sure to connect POSITIVE (+) battery cable to POSITIVE (+) battery terminal FIRST, and NEGATIVE (-) battery cable to NEGATIVE (-) battery terminal LAST. If battery cables are reversed, or connection order is reversed, electrical system damage will result.

- 2 Install fully-charged battery. Clean battery cable clamps and terminals and reconnect cables (see CAUTION listed above). Tighten each cable clamp securely when connecting.
- 3 Coat terminal connections with a battery terminal anti-corrosion agent.
- 4 Perform all checks in Operation, Maintenance and Warranty Manual "Operation Chart" in the "Before Starting" column.

CAUTION

Refer to FLUSHING COOLING SYSTEM before starting engine.

- 5 Start engine and closely observe instrumentation to make sure that all systems are functioning correctly.
- 6 Carefully inspect engine for fuel, oil, fluid, water and exhaust leaks.
- 7 Check steering system, shift and throttle control for proper operation.

Troubleshooting

Starter Motor Will Not Crank Engine, Or Cranks Slow

Possible Cause	Remedy
Battery switch turned off.	Turn switch on.
Remote control not in neutral position.	Position control lever in neutral.
Open circuit breaker or blown fuse.	Check and reset circuit breaker or replace fuse.
Loose or dirty electrical connections or damaged wiring.	Check all electrical connections and wires (especially battery cables). Clean and tighten faulty connection.
Bad battery.	Test and replace if bad.

Engine Will Not Start, Or Is Hard To Start

Possible Cause	Remedy
Improper starting procedure.	Read starting procedure.
Empty fuel tank or fuel shutoff valve closed.	Fill tank or open valve.
Choke not operating properly.	Carburetor Models: Check choke linkages for freedom of movement.
Engine flooded.	Do not attempt to start engine for at least 5 minutes. Refer to Starting Procedures.
Faulty ignition system component.	Service ignition system.
Clogged fuel filters.	Replace filters.
Stale or contaminated fuel.	If contaminated, drain tank. Fill with fresh fuel.
Fuel line or tank vent line kinked or clogged.	Replace kinked lines or blow out lines with compressed air to remove obstruction.
EFI System Fault (If So Equipped).	Have EFI System checked by an Authorized MerCruiser Dealer.

Engine Runs Rough, Misses And/Or Backfires

Possible Cause	Remedy
Idle speed too low.	EFI Models: Have EFI system checked by an Authorized MerCruiser Dealer.
Choke not operating properly.	Carburetor Models: Check choke linkages for binding or an obstruction.
Ignition System Fault.	Service ignition system.
Clogged fuel filter.	Replace filter.
Stale or contaminated fuel.	If contaminated, drain tank. Fill with fresh fuel.
Kinked or clogged fuel line or fuel tank vent line.	Replace kinked lines or blow out lines with compressed air to remove obstruction.
Flame Arrestor plugged with foreign material.	Clean Flame Arrestor.
EFI System Fault (If So Equipped).	Have EFI System checked by an Authorized MerCruiser Dealer.

Poor Performance

Possible Cause	Remedy
Throttle not fully open.	Inspect throttle cable and linkages for proper operation.
Damaged or improper propeller.	Replace propeller.
Excessive bilge water.	Drain and check for cause of entry.
Boat overloaded or load improperly distributed.	Reduce load or redistribute load more evenly.
Boat bottom fouled or damaged.	Clean or repair as necessary.
Flame Arrestor dirty.	Clean Flame Arrestor.
Ignition or carburetion problem.	See "Engine Runs Rough, Misses or Backfires."
Engine overheating.	See "Excessive Engine Temperature."
EFI System fault (If So Equipped).	Have EFI System checked by an Authorized MerCruiser Dealer.

CC522

Excessive Engine Temperature

Possible Cause	Remedy
Water Inlet valve closed (If So Equipped).	Open valve completely.
Drive belt loose or in poor condition.	Replace or adjust belt.
Seawater pickups obstructed.	Remove obstruction.
Faulty thermostat.	Replace.
Coolant level low in fresh water section. (If So Equipped)	Check for cause of low coolant level and repair. Fill system with proper coolant solution.
Heat Exchanger Cores plugged with foreign material (If So Equipped).	Clean Heat Exchanger.
Loss of pressure in fresh water section (If So Equipped).	Check for leaks. Clean, inspect and test pressure cap.
Kinked, collapsed, or broken hose.	Straighten or replace hose.
Transmission fluid cooler and/or engine oil cooler plugged with foreign material.	Disconnect hoses from coolers and flush out with a water hose in direction opposite normal water flow.

CA448

Insufficient Engine Temperature

Possible Cause	Remedy
Faulty Thermostat.	Replace.

CC523

Low Engine Oil Pressure

Possible Cause	Remedy
Insufficient oil in crankcase.	Check and add oil.
Excessive oil in crankcase (causing the oil to become aerated).	Check and remove required amount of oil. Check for cause of excessive oil (improper filling, bad fuel pump, etc.).
Engine oil cooler hose kinked (if so equipped) causing excessive oil temperature and thinning of the oil.	Straighten hose or replace, if damaged.
Diluted or improper viscosity oil.	Change oil and oil filter, using correct grade and viscosity oil. Determine cause for dilution (excessive idling, faulty fuel pump, etc.).

Excessive Transmission Fluid Temperature or Slipping Transmission

Possible Cause	Remedy
Low fluid level.	Maintain fluid level.
Transmission shift lever not positioned properly (causing clutches to slip and overheat fluid).	Inspect shift linkages and shift lever positioning.
Fluid cooler hoses kinked.	Straighten hoses or replace, if damaged.

CA450

Battery Will Not Come Up On Charge

Possible Cause	Remedy
Excessive current draw from battery.	Turn off non-essential accessories.
Loose or dirty electrical connections or damaged wiring.	Check all associated electrical connections and wires (especially battery cables). Clean and tighten faulty connections. Repair or replace damaged wiring.
Alternator drive belt loose or in poor condition.	Replace and/or adjust.
Unacceptable battery condition.	Test battery.

CA451

Remote Control Operates Hard, Binds, Has Excessive Free-play Or Makes Unusual Sounds

Possible Cause	Remedy
Insufficient lubrication on shift and throttle linkage fasteners.	Lubricate.
Loose or missing shift and throttle linkages.	Check all throttle linkages. If any are loose or missing, see Authorized MerCruiser Dealer immediately.
Obstruction in shift or throttle linkages.	Remove obstruction.
Shift or throttle cable kinked.	Straighten cable or have dealer replace cable if damaged beyond repair.

Owner Service Assistance

Local Repair Service

Always return your MerCruiser powered boat to your local Authorized Dealer, should the need for service arise. Only he has the factory trained mechanics, knowledge, special tools and equipment and the genuine Quicksilver parts and accessories* to properly service your engine should the need occur. He knows your engine best.

* Quicksilver parts and accessories are engineered and built by Mercury Marine, specifically for MerCruiser® sterndrives and inboards.

Service Away From Home

If you are away from your local dealer and the need arises for service, contact the nearest Authorized Dealer. Refer to the Yellow Pages of the telephone directory. If, for any reason, you cannot obtain service, contact the nearest Regional Service Center. Outside the United States and Canada, contact the nearest Marine Power International Service Center.

Parts And Accessories Inquiries

All inquiries concerning Quicksilver replacement parts and accessories should be directed to your local Authorized Dealer. The dealer has the necessary information to order parts and accessories for you should he not have them in stock. Only Authorized Dealers can purchase genuine Quicksilver parts and accessories from the factory. Mercury Marine does not sell to unauthorized dealers or retail customers. When inquiring on parts and accessories, the dealer requires the **motor model** and **serial number(s)** to order the correct parts.

Resolving A Problem

Satisfaction with your MerCruiser product is very important to your dealer and to us. If you ever have a problem, question or concern about your power package, contact your dealer or any Authorized Mercruiser Dealership. If additional assistance is required, take these steps.

1 *Talk with the dealership's sales manager or service manager. If this has already been done, then contact the owner of the dealership.*

2 *Should you have a question, concern or problem that cannot be resolved by your dealership, please contact Mercury Marine Service Office for assistance. Mercury Marine will work with you and your dealership to resolve all problems.*

The following information will be needed by the service office:

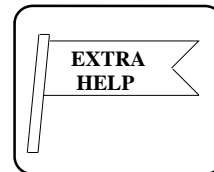
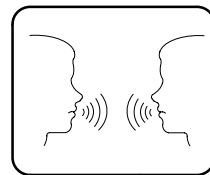

- Your name and address
- Daytime telephone number
- Model and serial numbers for your power package.
- The name and address of your dealership
- Nature of problem

Mercury Marine Service Offices are listed on the next page.



Mercury Marine Service Offices

For assistance, call, fax, or write. Please include your daytime telephone number with mail and fax correspondence.

Telephone 	Fax 	Mail 
United States		
(405) 743-6566	(405) 743-6570	MerCruiser 3003 N. Perkins Rd. Stillwater, OK 74075
Canada		
(905) 567-MERC (6372)	(905) 567-8515	Mercury Marine Ltd. 2395 Meadowpine Blvd. Mississauga, Ontario Canada L5N 7W6
Australia, Pacific		
(61) (3) 791-5822	(61) (3) 793-5880	Mercury Marine Australia 132-140 Frankston Road Dandenong, Victoria 3164 Australia
Europe, Middle East, Africa		
(32) (87) 32 • 32 • 11	(32) (87) 31 • 19 • 65	Marine Power - Europe, Inc. Parc Industriel de Petit-Rechain B-4800 Verviers Belgium
Mexico, Central America, South America, Caribbean		
(305) 385-9585	(305) 385-5507	Mercury Marine - Latin America & Caribbean 9010 S.W. 137th Ave. Suite 226 Miami, FL 33186 U.S.A.
Japan		
(81) 543/34-2500	(81) 543/34-2022	Mercury Marine - Japan No. 27-2 Muramatsu Chisaki-Shinden Shimizu City Shizuoka Prefecture Japan 424
Asia, Singapore		
5466160	5467789	Mercury Marine Singapore 72 Loyang Way Singapore 508762

Customer Service Literature

English Language

English language publications are available from:

Mercury Marine
Attn: Publications Department
W6250 West Pioneer Road
P.O. Box 1939
Fond du Lac, WI 54936-1939

Outside the United States and Canada, contact the nearest Mercury Marine or Marine Power International Service Center for further information.

When ordering be sure to:

1. List your product, model, year and serial number(s).
2. Check the literature and quantities you want.
3. Enclose full remittance in check or money order (NO C.O.D.'s).

CA781

Other Languages

To obtain an Operation and Maintenance and Warranty Manual in another language, contact the nearest Mercury Marine or Marine Power International Service Center for information. A list of part numbers for other languages is provided with your power package.

caa781

Andre sprog

Kontakt det nærmeste Mercury Marine eller Marine Power International servicecenter for oplysninger om hvordan du kan anskaffe en Betjenings- og vedligeholdelsesmanual på et andet sprog. En liste med reservedelsnumre for andre sprog leveres sammen med din power-pakke.

cab781

Andere talen

Voor het verkrijgen van een Handleiding voor gebruik en onderhoud in andere talen dient u contact op te nemen met het dichtstbijzijnde internationale servicecentrum van Mercury Marine of Marine Power voor informatie hierover. Een lijst met onderdeelnummers voor andere talen wordt bij uw motorinstallatie geleverd.

cac781

Muut kielet

Saadaksesi Käyttö- ja huolto-ohjekirjoja muilla kielillä, ota yhteys lähimpään Mercury Marine tai Marine Power International huoltokeskukseen, josta saat lähempiä tietoja. Moottorisi mukana seuraa monikielinen varaosanumeroluettelo.

cad781

Autres langues

Pour obtenir un Manuel d'utilisation et d'entretien dans une autre langue, contactez le centre de service après-vente international Mercury Marine ou Marine Power le plus proche pour toute information. Une liste des numéros de pièces en d'autres langues accompagne votre bloc-moteur.

cae781

Andere Sprachen

Um eine Betriebs- und Wartungsanleitung in einer anderen Sprache zu erhalten, wenden Sie sich an das nächste Mercury Marine oder Marine Power International Service Center. Eine Liste mit Teilenummern für Fremdsprachen ist im Lieferumfang Ihres Motors enthalten.

caf781

Altre lingue

Per ottenere il manuale di funzionamento e manutenzione in altra lingua, contattate il centro assistenza internazionale Mercury Marine o Marine Power più vicino. In dotazione con il gruppo motore, viene fornito l'elenco dei codici prodotto dei componenti venduti all'estero.

cag781

Andre språk

Ytterligere informasjon om bruks- og vedlikeholdshåndbok på andre språk kan fås ved henvendelse til nærmeste internasjonale servicecenter for Mercury Marine eller Marine Power. En liste over delenumre for andre språk følger med aggregatet.

cah781

Outros Idiomas

Para obter um Manual de Operação e Manutenção em outro idioma, contate o Centro de Serviço Internacional de "Marine Power" (Potência Marinha) ou a Mercury Marine mais próxima para obter informações. Uma lista de números de referência para outros idiomas é fornecida com o seu pacote de propulsão.

caj781

Otros idiomas

Para obtener un Manual de operación y mantenimiento en otro idioma, póngase en contacto con el centro de servicio más cercano de Mercury Marine o Marine Power International para recibir información. Con su conjunto motriz se entrega una lista de los números de pieza para los otros idiomas.

cak781

Andra språk

För att få Instruktions- och underhållsböcker på andra språk, kontakta närmaste Mercury Marine eller Marine Power International servicecenter, som kan ge ytterligare information. En förteckning över artikelnummer på andra språk medföljer ditt kraftpaket.

CAm781

Άλλες γλώσσες

Για να αποκτήσετε ένα Εγχειρίδιο Λειτουργίας και Συντήρησης σε άλλη γλώσσα, επικοινωνήστε με το πλησιέστερο Διεθνές Κέντρο Σέρβις της Mercury Marine ή της Marine Power για πληροφορίες. Το πακέτο ισχύος σας συνοδεύεται από έναν κατάλογο αριθμών παραγγελίας για άλλες γλώσσες.

Ordering Literature

Before ordering literature, please have the following information about your power package available:



Model _____ **Horsepower** _____

Serial Number _____ **Year** _____

United States and Canada

For information on additional literature that is available for your particular MerCruiser power package and how to order that literature contact your nearest dealer or contact:

Mercury Marine

Telephone 	Fax 	Mail 
(920) 929-5110	(920) 929-4894	Mercury Marine Attn: Publications Department P.O. Box 1939 Fond du Lac, WI 54936-1939

Outside The United States and Canada

Contact your nearest dealer or Marine Power Service Center for information on additional literature that is available for your particular MerCruiser power package and how to order that literature.