

Gasoline Engines - Bravo Models

Identification Record

PLEASE RECORD THE FOLLOWING INFORMATION:

1.

 Engine Model and
Horsepower

 Engine
Serial Number

2.

 Transom Assembly Serial
Number (Sterndrive)

 Gear
Ratio

 Sterndrive Unit
Serial Number

3.

 Transmission Model
(Inboard)

 Gear
Ratio

 Transmission
Serial Number

4.

 Propeller Number

Pitch

 Diameter

5.

 Hull Identification Number
(HIN)

 Purchase
Date

6.

 Boat Manufacturer

 Boat
Model

 Length

7.

 Exhaust Gas Emissions Certificate Number (Europe Only)

SERIAL NUMBERS

The serial numbers are the manufacturer's keys to numerous engineering details which apply to your MerCruiser® power package. When contacting your Authorized MerCruiser Dealer about service, **always specify model and serial numbers.**

The description and specifications contained herein were in effect at the time this guide was approved for printing. Mercury Marine, whose policy is one of continuous improvement, reserves the right to discontinue models at any time, or to change specifications or designs, without notice and without incurring obligation.

Mercury Marine, Fond du Lac, Wisconsin, U.S.A.

Printed in U.S.A.

©1998, Mercury Marine

The following are registered trademarks of Brunswick Corporation: Auto-blend, Jet-Prop, Mariner, Merc, MerCathode, MerCruiser, Mercury, Mercury Marine, Quicksilver, Ride-Guide, and Thruster.

MERCURISER
Division of Mercury Marine
Stillwater, OK, U.S.A.

SPECIFICATIONS

MODEL . MCM 4 3LX4 3LXH GEN +
DISPLACEMENT 282 CID
IGNITION TIMING 10 BTDC
CYL. FIRING ORDER ... 1-6-5-4-3-2
SPARK PLUGS AC-MR43LTS
ENGINE ROTATION LH
MAX. W.O.T. RPM 4400-4800
IDLE RPM IN NEUTRAL 650
PLUG GAP045

For Fuel and Oil requirements refer to
Operators & Maintenance Manual

SERIAL NUMBERS

COLOR CODE

1,2 74677

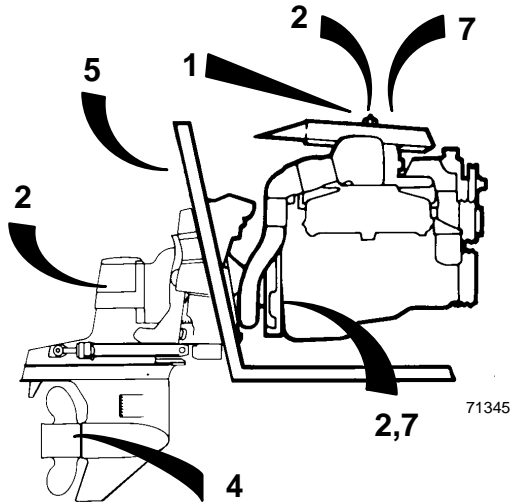
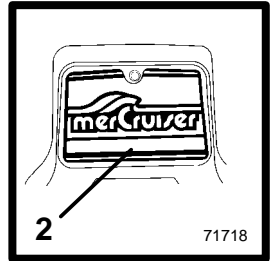
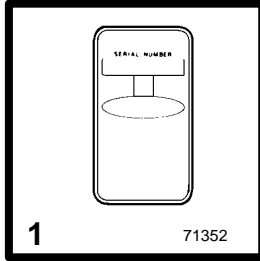

ABC12345Z123

5

-19

4

48-12345

4

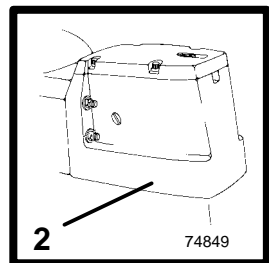

TABLE OF CONTENTS

	Page
Welcome!	4
Warranty Message	4
Read This Manual Thoroughly	5
Lanyard Stop Switch	6
Exhaust Emissions	9
Be Alert To Carbon Monoxide Poisoning	9
Safe Boating Suggestions	12
Protecting People In The Water	15
While You Are Cruising	15
While Boat Is Stationary	15
High-Speed And High-Performance Boat Operation	15
Conditions Affecting Operation	16
Weight Distribution	16
Bottom Of Boat	16
Cavitation	17
Ventilation	17
Propeller Selection	17
How Elevation And Climate Affect Performance	19
Important Information	20
Operation And Maintenance	20
Freezing Temperature Operation	21
Drive Unit Impact Protection	21
Drain Plug and Bilge Pump	21
Emissions Information (Europe Only)	22
Attention Required After Submersion	22
Trailing Boat	22
Launching And Boat Operation Care	23
Stolen Power Package	23
Replacement Service Parts	24
Do-It-Yourself Maintenance Suggestions	25
Multiple EFI Engine Battery Precautions	26
Diagnosing EFI Problems (If Equipped)	27
Water Separating Fuel Filter	27
20-Hour Break-In Period	28
After Break-In Period	29
End of First Season Checkup	29
Operation	31
Instrumentation	31
Audio Warning System	33
Electrical System Overload Protection	35
Remote Controls (Panel Mounted)	39
Remote Controls (Console Mounted)	41
Remote Controls (Two Lever)	43

	Page
Power Trim	45
Starting, Shifting And Stopping	52
Operation Chart	55
Specifications	56
Fuel Recommendations	56
Crankcase Oil	58
Engine Specifications (V-6 Models)	59
Engine Specifications (V-8 Models)	60
Maintenance	64
Maintenance Aids	64
Maintenance Chart	65
Checking Fluid Levels	71
Propellers (Bravo One and Two)	75
Propellers (Bravo Three)	79
Flushing Cooling System	83
Serpentine Drive Belt	85
Corrosion And Corrosion Protection	87
Emissions (Europe Only)	93
Sealed Carburetor Mixture Screws	93
Changing Positive Crankcase Ventilation Valve (PCV) ...	93
Emissions Testing	95
Installing Test Probes	95
Miscellaneous Maintenance	96
Battery	96
Bottom Of Boat	97
Inspection And Maintenance	97
Cold Weather Or Extended Storage	98
Power Package Lay Up	98
Battery Winter Storage	98
Do-It-Yourself Maintenance	98
Power Package Recommissioning	98
Troubleshooting	100
Warranty Information	107
Warranty Policies	109
3 Year Limited Warranty Against Corrosion Failure	114
Warranty Coverage	116
Transferable Warranty	119
Q-Guard Product Protection Plan	120
Owner Service Assistance	121
Customer Service Literature	124
Literature Order Form	127

Welcome!

You have selected one of the finest marine power packages available. It incorporates numerous design features to assure operating ease and durability.

With proper care and maintenance, you will thoroughly enjoy using this product for many boating seasons. To ensure maximum performance and carefree use, we ask that you thoroughly read this manual.

The Operation and Maintenance Manual contains specific instructions for using and maintaining your product. We suggest that this manual remain with the product for ready reference whenever you are on the water.

Thank you for purchasing one of our MerCruiser products. We sincerely hope your boating will be pleasant!

Consumer Affairs Department

Warranty Message

The product you have purchased comes with a **limited warranty** from Mercury Marine; the terms of the warranty are set forth in the *Warranty* Sections of this manual. The warranty statement contains a description of what is covered, what is not covered, the duration of coverage, how to best obtain warranty coverage, **important disclaimers and limitations of damages**, and other related information. Please review this important information.

IMPORTANT: This manual contains basic Operation and Maintenance information for your MerCruiser power package. If you desire to perform some of the maintenance items on your own, you should obtain a copy of the “Maintenance Procedures” Manual for your particular power package. Information for obtaining this manual is located at the back of this manual.

Read This Manual Thoroughly

IF YOU DON'T UNDERSTAND ANY PORTION, CONTACT YOUR DEALER FOR A DEMONSTRATION OF ACTUAL STARTING AND OPERATING PROCEDURES.

NOTICE

Throughout this publication, and on your power package, **WARNINGS** and **CAUTIONS**, accompanied by the International Hazard Symbol , may be used to alert the installer/user to special instructions concerning a particular service or operation that may be hazardous if performed incorrectly or carelessly. **Observe them carefully.**

These "Safety Alerts" alone cannot eliminate the hazards that they signal. Strict compliance with these special instructions while performing the service, plus "common sense" operation, are major accident prevention measures.

WARNING

WARNING-Hazards or unsafe practices which could result in severe personal injury or death.

CAUTION

CAUTION-Hazards or unsafe practices which could result in minor personal injury or product or property damage.

IMPORTANT: Indicates information or instructions that are necessary for proper operation and /or maintenance.

WARNING

The operator (driver) is responsible for the correct and safe operation of the boat, the equipment aboard and the safety of all occupants aboard. We strongly recommend that the operator read this Operation and Maintenance Manual and thoroughly understand the operational instructions for the power package and all related accessories before the boat is used.

Lanyard Stop Switch

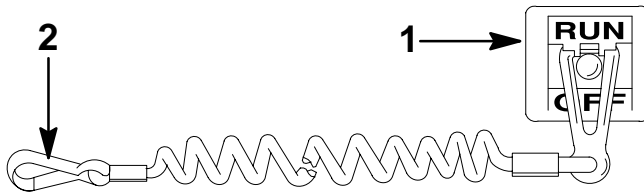

74608

The purpose of a lanyard stop switch (1) is to turn off the engine when the operator moves far enough away from the operator's position (as in accidental ejection from the operator's position) to activate the switch. Some remote control units are equipped with a lanyard stop switch. A lanyard stop switch can be installed on the dashboard or side adjacent to the operator's position.

The lanyard is a cord usually between 4 and 5 feet (1220 and 1524 mm) in length when stretched out with an element on one end made to be inserted into the switch and a snap (2) on the other end for attaching to the operator. The lanyard is coiled to make its at-rest condition as short as possible so as to minimize the likelihood of lanyard entanglement with nearby objects. It is made as long as it is in its stretched condition to minimize the likelihood of accidental activation should the operator choose to move around in an area close to the normal operator's position. If it is desired to have a shorter lanyard, wrap the lanyard around the operator's wrist or leg, or tie a knot in the lanyard.

IMPORTANT: The purpose of a lanyard stop switch is to stop the engine when the operator moves far enough away from the operator's position to activate the switch. This would occur if the operator accidentally falls overboard or moves within the boat a sufficient distance from the operator's position. Accidental ejections and falls overboard are more likely to occur in certain types of boats such as low sided sport boats or bass boats, and high-performance boats. Accidental ejections and falls overboard are also likely to occur as a result of poor operating practices such as sitting on the back of the seat or gunwale at planing speeds, standing at planing speeds, sitting

on elevated fishing boat decks, operating at planing speeds in shallow or obstacle-infested waters, releasing your grip on a steering wheel that is pulling in one direction, drinking alcohol or consuming drugs, or daring, high-speed boat maneuvers.

While activation of the lanyard stop switch will stop the engine immediately, a boat will continue to coast for some distance depending upon the velocity and degree of any turn at shut-down. However, the boat will not complete a full circle. While the boat is coasting, it can cause injury to anyone in the boat's path as seriously as the boat would when under power.

We strongly recommend that other occupants be instructed on proper starting and operating procedures should they be required to operate the engine in an emergency (e.g. if the operator is accidentally ejected).

 WARNING

Should the operator fall out of the boat, the possibility of serious injury or death from being run over by the boat can be greatly reduced by stopping the engine immediately. Always properly connect both ends of the stop switch lanyard to the stop switch and the operator.

Accidental or unintended activation of the switch during normal operation is also a possibility. This could cause any, or all, of the following potentially hazardous situations:

- 1** Occupants could be thrown forward due to unexpected loss of forward motion – a particular concern for passengers in the front of the boat who could be ejected over the bow and possibly struck by the gear case or propeller.
- 2** Loss of power and directional control in heavy seas, strong current or high winds.
- 3** Loss of control when docking.

 WARNING

Avoid serious injury or death from deceleration forces resulting from accidental or unintended stop switch activation. The boat operator should never leave the operator's station without first disconnecting the stop switch lanyard from the operator.

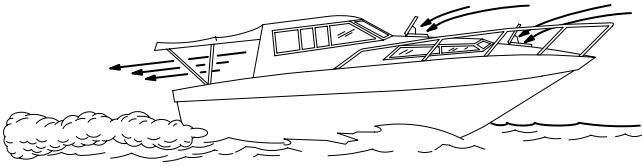

1

Exhaust Emissions

Be Alert To Carbon Monoxide Poisoning

Carbon monoxide is present in the exhaust fumes of all internal combustion engines including the outboards, sterndrives and inboard engines that propel boats, as well as the generators that power various boat accessories. Carbon monoxide is a deadly gas that is odorless, colorless and tasteless.

Early symptoms of carbon monoxide poisoning, which should not be confused with seasickness or intoxication, include headache, dizziness, drowsiness, and nausea.

WARNING

Avoid the combination of a running engine and poor ventilation. Prolonged exposure to carbon monoxide in sufficient concentration can lead to unconsciousness, brain damage or death.

GOOD VENTILATION

Ventilate passenger area, open side curtains, or forward hatches to remove fumes.

- 1 Example of desired air flow through the boat.

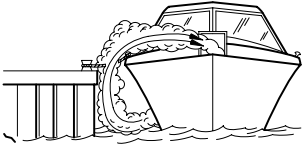

2A

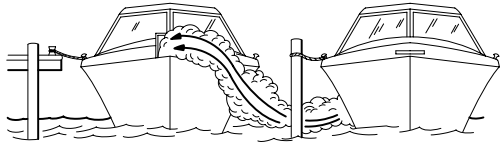

2B



3A



3B

POOR VENTILATION

Under certain running and/or wind conditions, permanently enclosed or canvas enclosed cabins or cockpits with insufficient ventilation may draw in carbon monoxide. Install one or more carbon monoxide detectors in your boat.

Although the occurrence is rare, on a very calm day, swimmers and passengers in an unclosed area of a stationary boat that contains or is near a running engine may be exposed to a hazardous level of carbon monoxide.

2 Examples of poor ventilation while boat is stationary:

A Running the engine when the boat is moored in a confined space.

B Mooring close to another boat that has its engine running.

3 Examples of poor ventilation while boat is moving:

A Running the boat with the trim angle of the bow too high.

B Running the boat with no forward hatches open (station wagon effect).

Safe Boating Suggestions

In order to safely enjoy the waterways, familiarize yourself with local and other governmental boating regulations and restrictions, and consider the following suggestions.

- **Know and obey all nautical rules and laws of the waterways.** Boat operators should complete a boating safety course. Courses are offered in the U.S.A. by (1) The U.S. Coast Guard Auxiliary, (2) The Power Squadron, (3) The Red Cross and (4) your state or provincial boating law enforcement agency. Inquiries may be made to the Boating Hotline, 1-800-368-5647 or the Boat U.S. Foundation information number 1-800-336-BOAT.

We strongly recommend that all powerboat operators attend one of these courses.

You should also review the NMMA Sources of Waterway Information booklet. It lists regional sources of safety, cruising and local navigation and is available at no charge by writing to:

Sources of Waterway Information
National Marine Manufacturers Association
410 N. Michigan Avenue
Chicago, IL 60611 U.S.A.

- **Perform safety checks and required maintenance.** Follow a regular schedule and ensure that all repairs are properly made.
- **Check safety equipment on board.** Here are suggestions of the types of safety equipment to carry when boating:
 - 1 Approved fire extinguisher(s); paddle or oar.
 - 2 Signal devices: flashlight, rockets or flares, flag and whistle or horn.
 - 3 Spare propeller, thrust hubs and an appropriate wrench.
 - 4 Tools for necessary minor repairs; first aid kit and book.
 - 5 Anchor and extra anchor line; water-proof storage containers.
 - 6 Manual bilge pump and extra drain plugs; compass and map or chart of area.
 - 7 Spare operating equipment; batteries, bulbs, fuses, etc.
 - 8 Transistor radio.
 - 9 Drinking water.

- **Know signs of weather change and avoid foul weather and rough-sea boating.**
- **Tell someone where you are going and when you expect to return.**
- **Passenger boarding.** Stop the engine whenever passengers are boarding, unloading or are near the back (stern) of the boat. Just shifting the drive unit into neutral is not sufficient.
- **Use personal flotation devices.** Federal Law requires that there be a U. S. Coast Guard approved, wearable-type life jacket (personal flotation device), correctly sized and readily accessible for every person on board, plus a throwable cushion or ring. We strongly advise that everyone wear a life jacket at all times while in the boat.
- **Prepare other boat operators.** Instruct at least one person on board in the basics of starting and operating the engine and boat handling in case the driver becomes disabled or falls overboard.
- **Do not overload your boat.** Most boats are rated and certified for maximum load (weight) capacities (refer to your boat capacity plate). Know your boat's operating and loading limitations. Know if your boat will float if full of water. When in doubt, contact your dealer or the boats manufacturer.
- **Make sure everyone in the boat is properly seated.** Don't allow anyone to sit or ride on any part of the boat that was not intended for such use. This includes backs of seats, gunwales, transom, bow, decks, raised fishing seats, any rotating fishing seat; anywhere that sudden unexpected acceleration, sudden stopping, unexpected loss of boat control or sudden boat movement could cause a person to be thrown overboard or into the boat. See that all passengers have a proper seat and are in it before any boat movement.
- **Never be under the influence of alcohol or drugs while boating (it is the law).** They impair your judgment and greatly reduce your ability to react quickly.

- **Know your boating area and avoid hazardous locations.**
- **Be alert.** The operator of the boat is responsible by law to “maintain a proper lookout by sight (and hearing).” The operator must have an unobstructed view particularly to the front. No passengers, load, or fishing seats should block the operators view when operating the boat above idle or planing transition speed. Watch “the other guy,” the water and your wake.
- **Never drive your boat directly behind a water skier in case the skier falls.** As an example, your boat traveling at 25 miles per hour (40 km/hr) in 5 seconds will overtake a fallen skier who was 200 feet in front of you.
- **Watch fallen skiers.** When using your boat for water skiing or similar activities, always keep a fallen or down skier on the operator’s side of the boat while returning to attend the skier. The operator should always have the down skier in sight and never back up to the skier or anyone in the water.
- **Report accidents.** Boat operators are required by law to file a Boating Accident Report with their state boating law enforcement agency when their boat is involved in certain boating accidents. A boating accident must be reported if (1) there is loss of life or probable loss of life, (2) there is personal injury requiring medical treatment beyond first aid, (3) there is damage to boats or other property where the damage value exceeds \$500.00 or (4) there is complete loss of the boat. Seek further assistance from local law enforcement.

Protecting People In The Water

While You Are Cruising

It is very difficult for a person standing or floating in the water to take quick action to avoid a boat heading in his/her direction even at slow speed.

Always slow down and exercise extreme caution any time you are boating in an area where there might be people in the water.

Whenever a boat is moving (coasting) and the drive unit is in neutral position, there is sufficient force by the water on the propeller to cause the propeller to rotate. This neutral propeller rotation can cause serious injury.

While Boat Is Stationary

Shift the drive unit into neutral and shut off the engine before allowing people to swim or be in the water near your boat.

WARNING

Stop your engine immediately whenever anyone in the water is near your boat. Serious injury to the person in the water is likely if contacted by a rotating propeller, a moving boat, a moving gear case, or any solid device rigidly attached to a moving boat or gear case.

High-Speed And High-Performance Boat Operation

If your boat is considered a high-speed or high-performance boat with which you are unfamiliar, we recommend that you never operate it at its high speed capability without first requesting an initial orientation and familiarization demonstration ride with your dealer or an operator experienced with your boat. For additional information, obtain a copy of our “Hi-Performance Boat Operation” booklet (Part Number 90-849250--1) from your dealer, distributor, or Mercury Marine.

Conditions Affecting Operation

Weight Distribution

Positioning of weight (passengers and gear) inside the boat has the following effects:

Shifting weight to rear (stern) will:

- Generally increases speed and engine RPM.
- At extremes can cause boat to porpoise.
- Causes bow to bounce in choppy water.
- Increases danger of following wave splashing into boat when coming off plane.

Shifting weight to front (bow) will:

- Improve ease of planing.
- Improve rough water ride.
- At extremes, can cause boat to veer back and forth (bow steer).

Bottom Of Boat

To maintain maximum speed, the following conditions of the boat bottom should be observed.

- A. Clean, free of barnacles and marine growth.
- B. Free of distortion; nearly flat where it contacts the water.
- C. Straight and smooth, fore and aft.

Marine vegetation may accumulate when boat is docked. This growth must be removed before operation; it may clog water inlets and cause engine to overheat.

CA9

Cavitation

Cavitation occurs when water flow cannot follow the contour of a fast-moving underwater object, such as a gear housing or propeller. Cavitation permits the propeller to speed up, but the boat speed to reduce. Cavitation can seriously erode the surface of the gear housing or propeller. Common causes of cavitation are:

- A. Weeds or other debris snagged on propeller or gear housing.
- B. Bent propeller blade or damaged gear housing skeg.
- C. Raised burrs or sharp edges on propeller or gear housing.

CA10

Ventilation

Ventilation is caused by surface air or exhaust gases which are introduced around the propeller resulting in propeller speedup and a reduction in boat speed. Excessive ventilation is annoying and usually caused by:

- A. Drive unit trimmed out too far.
- B. A missing propeller diffuser ring.
- C. A damaged propeller or gear housing, which allows exhaust gases to escape between propeller and gear housing.
- D. Drive unit installed too high on transom.

CA294

Propeller Selection

IMPORTANT: Installed propeller must allow engine to run at its specified maximum wide-open-throttle revolutions per minute (RPM). Use an accurate service tachometer to verify engine operating RPM.

It is the responsibility of the boat manufacturer and/or the selling dealer to equip the power package with the correct propeller(s). Specified engine wide-open-throttle (WOT) and operating RPM range are listed in "SPECIFICATIONS."

IMPORTANT: The engines covered in this manual are equipped with an RPM rev-limiter that is set to an upper (or limited) RPM amount. This limit is slightly above the normal operating range of the engine and is designed to help prevent damage from excessive engine RPM. Once the RPM drops into the recommended operating RPM range normal engine operation resumes.

Select a propeller that will allow the engine power package to operate at or near the top end of the recommended wide-open-throttle operating RPM range with a normal load. High RPM, caused by an excessive trim angle, should not be used in determining correct propeller selection.

If full throttle operation is below the recommended range, the propeller must be changed to prevent loss of performance and possible engine damage. On the other hand, operating an engine above the recommended operating RPM range will cause higher than normal wear and/or damage. Generally, there is a 200-300 RPM change between propeller pitches.

After initial propeller selection, the following common problems may require that the propeller be changed to a lower pitch:

- Warmer weather and greater humidity cause an RPM loss.
- Operating in a higher elevation causes an RPM loss.
- Operating with a damaged propeller or dirty boat bottom causes an RPM loss.
- Operating with increased load (additional passengers, pulling skiers, etc.).

For better acceleration, such as is needed for water skiing, use the next lower pitch propeller. However, do not operate at full throttle when using the lower pitch propeller but not pulling skiers.

How Elevation And Climate Affect Performance

Elevation has a very noticeable effect on the wide-open-throttle power of an engine. Since air (containing oxygen) gets thinner as elevation increases, the engine begins to starve for air. Humidity, barometric pressure and temperature do have a noticeable effect on the density of air. Heat and humidity thin the air. This condition can become particularly annoying when the propeller testing was done on a cool, dry day. Then later, on a hot, sultry day, the boat doesn't seem to have the same performance.

Although some performance can be regained by dropping to a lower pitch propeller, the basic problem still exists. In some cases, a gear ratio change to more reduction is possible and very beneficial.

Summer conditions of high temperature, low barometric pressure and high humidity all combine to reduce the engine power. This, in turn, is reflected in decreased boat speeds, as much as 2 or 3 miles per hour in some cases. Nothing will regain this speed for the boater, but the coming of cool, dry weather.

In pointing out the practical consequences of weather effects, an engine running on a hot, humid, summer day, may encounter a loss of as much as 14% of the horsepower it would produce on a dry, brisk spring or fall day. With the drop in available horsepower, this propeller will, in effect, become too large. Consequently, the engine operates at less than its recommended RPM. This will result in further loss of horsepower at the propeller with another decrease in boat speed. This secondary loss, however, can be somewhat regained by switching to a lower-pitch propeller that allows the engine to again run at recommended RPM.

For boaters to realize optimum engine performance under changing weather conditions, it is essential that the engine be propped to allow it to operate at or near the top end of the recommended maximum RPM range at wide-open-throttle with a normal boat load.

Not only does this allow the engine to develop full power, but equally important is the fact that the engine also will be operating in an RPM range that discourages damaging detonation. This, of course, enhances overall reliability and durability of the engine.

Important Information

Operation And Maintenance

OWNER/OPERATOR RESPONSIBILITIES

It is the operator's responsibility to perform all safety checks; to ensure that all lubrication and maintenance instructions are complied with for safe operation and to return the unit to an Authorized MerCruiser Dealer for a periodic checkup.

Normal maintenance service and replacement parts are the responsibility of the owner/operator and as such, are not considered defects in workmanship or material within the terms of the warranty. Individual operating habits and usage contribute to the need for maintenance service.

Proper maintenance and care of your power package will assure optimum performance and dependability, and will keep your overall operating expenses at a minimum. See your Authorized MerCruiser Dealer for service aids.

DEALER RESPONSIBILITIES

In general, a dealer's responsibilities to the customer include predelivery inspection and preparation such as:

- Make sure that the boat is properly equipped.
- Prior to delivery, make certain that the MerCruiser power package and other equipment are in proper operating condition.
- Make all necessary adjustments for maximum efficiency.
- Familiarize the customer with the on-board equipment.
- Explain and demonstrate the operation of the power package and boat.
- At the time of delivery, the dealer should provide you with a copy of a Predelivery Inspection Checklist.
- Your selling dealer should fill out the Warranty Registration Card completely and mail it to the factory immediately upon sale of the new product.

CA407

Freezing Temperature Operation

IMPORTANT: If boat is operated during periods of freezing temperature, precautions must be taken to prevent freezing damage to power package. Damage caused by freezing **IS NOT** covered by MerCruiser Limited Warranty.

CA17

Drive Unit Impact Protection

The Power Trim hydraulic system is designed to provide impact protection for drive unit. If a submerged object is struck while boat is moving forward, the hydraulic system will cushion the pickup of drive unit as it clears the object, reducing damage to unit. After drive unit has cleared object, the hydraulic system allows drive unit to return to original operating position, preventing loss of steering control and engine overspeed.

Use extreme caution when operating in shallow water or where underwater objects are known to be present. Use extreme care to prevent striking submerged object while operating in REVERSE. No impact protection is provided in REVERSE.

If drive unit should strike a submerged object, stop engine as soon as possible and inspect drive unit for damage. If damage is present or suspected, boat should be taken to an Authorized MerCruiser Dealer for thorough inspection and necessary repair. Operating a damaged drive unit could cause additional damage to other parts of drive unit, or could affect control of boat. If continued running is necessary, do so at greatly reduced speeds.

IMPORTANT: Impact protection system cannot be designed to ensure total protection from impact damage under all conditions.

CA408

Drain Plug and Bilge Pump

The engine compartment in your boat is a natural place for water to collect. For this reason, boats are normally equipped with a drain plug and/or a bilge pump. It is very important to check these items on a regular basis to ensure that the water level does not rise to come in contact with your power package. Components on your engine will be damaged if submerged. Damage caused by submersion is not covered by the MerCruiser Limited Warranty.

CA621

Emissions Information (Europe Only)

Your engine may be equipped with special design features and special tuning to minimize the emission output from the engine. If so, it is very important that you strictly adhere to the following:

- Recommended maintenance schedules particularly the ignition system.
- Proper engine tuning procedures to ensure these features remain in good operating order.
- Proper steps to maintain the engine within specifications.

Use only MerCruiser replacement parts to ensure compliance with emission regulations.

IMPORTANT: The testing dealer or agency will be equipped with the appropriate test equipment and adapters for this engine. Refer to “Emissions Testing” procedure found later in this manual.

CA409

Attention Required After Submersion

- Before recovery, contact an Authorized MerCruiser Dealer.
- After recovery, immediate service by an Authorized MerCruiser Dealer is required to prevent serious damage to power package.

CA19

Trailing Boat

Boat can be trailered with drive unit in “up” or “down” position. Adequate road clearance is required between road and gear housing skeg when trailering with drive unit in “down” position.

If adequate road clearance is a problem, place drive unit in full trailer position and support with an optional trailer kit which is available from your Authorized MerCruiser Dealer.

CA20

Launching And Boat Operation Care

CAUTION

During launching from a trailer, if the unloading ramp is steep or the trailer bed must be tilted, the boat may enter the water rapidly and at a steep angle. This may force water through the exhaust system into the cylinders. The more weight on the transom, the more likely this is to occur.

Slowing down rapidly or stopping suddenly may cause a following wave to “swamp” the transom. In this instance, water may enter the cylinders through the exhaust system.

When backing up rapidly, the same situation may occur as stated in the preceding paragraph.

In any of these situations, water entering the engine could cause severe damage to internal parts. Refer to “Attention Required After Submersion.”

CA21

Stolen Power Package

If your power package is stolen, immediately advise the local authorities and Mercury Marine of the model and serial number(s) and to whom the recovery is to be reported. This “Stolen Motor” information is placed into a file at Mercury Marine to aid authorities and dealers in recovery of stolen motors.

Replacement Service Parts

WARNING

Electrical, ignition and fuel system components on MerCruiser gasoline power packages are designed and manufactured to comply with U.S. Coast Guard rules and regulations to minimize risks of fire or explosion.

Use of replacement electrical, ignition or fuel system components, which do not comply to these rules and regulations, could result in a fire or explosion hazard and should be avoided.

When servicing the electrical, ignition and fuel systems, it is extremely important that all components are properly installed and tightened. If not, any electrical or ignition component would permit sparks to ignite fuel vapors from fuel system leaks, if they existed.

Marine engines are expected to operate at or near full-throttle for most of their life. They are also expected to operate in both fresh and saltwater environments. These conditions require numerous special parts. Care should be exercised when replacing marine engine parts as specifications are quite different from those of the standard automotive engine.

For example, one of the most important, and probably the least suspected special replacement part, is the cylinder head gasket. Since saltwater is highly corrosive, the steel-type automotive head gasket cannot be used. A marine engine head gasket uses special materials to resist corrosive action.

Since marine engines must be capable of running at or near maximum RPM much of the time, special valve springs, valve lifters, pistons, bearings, camshafts and other heavy-duty moving parts are required for long life and peak performance.

These are but a few of the many special modifications that are required in MerCruiser marine engines to provide long life and dependable performance.

Do-It-Yourself Maintenance Suggestions

If you are one of those persons who likes to do-it-yourself, here are some suggestions for you.

- Present-day marine equipment, such as your MerCruiser power package, are highly technical pieces of machinery. Electronic ignition and special fuel delivery systems provide greater fuel economies, but also are more complex for the untrained mechanic.
- Do not attempt any repairs which are not covered in this manual unless you are aware of the precautions (“Cautions” and “Warnings”) and procedures required. Your safety is of our concern.
- If you attempt to service the product yourself, we suggest you order the Maintenance Procedures Manual for that model. This manual outlines the correct procedures to follow. Do not attempt repairs if you do not understand the procedures.
- There are special tools and equipment that are required to perform some repairs. Do not attempt these repairs unless you have these special tools and/or equipment. You can cause damage to the product in excess of the cost a dealer would charge you.
- Also, if you partially disassemble an engine or drive assembly and are unable to repair it, the dealer’s mechanic must reassemble the components and test to determine the problem. This will cost you more than taking it to the dealer immediately upon having a problem. It may be a very simple adjustment to correct the problem.
- Do not telephone the dealer, service office or the factory to attempt for them to diagnose a problem or request the repair procedure. It is difficult for them to diagnose a problem over the telephone.
- Your Authorized Dealer is there to service your power package. They have qualified factory-trained mechanics.

It is recommended you have the dealer do periodic maintenance checks on your power package. Have them winterize it in the fall and service it before the boating season. This will reduce the possibility of any problems occurring during your boating season when you want trouble-free boating pleasure.

Multiple EFI Engine Battery Precautions

Situation

Alternators: Alternators are designed to charge the battery that supplies electrical power to the engine that the alternator is mounted on. When batteries for two different engines are connected, one alternator will supply all of the charging current for both batteries. Normally, the other engine's alternator will not be required to supply any charging current.

EFI Electronic Control Module (ECM): The ECM requires a stable voltage source. During multiple engine operation, an onboard electrical device may cause a sudden drain of voltage at the engine's battery. The voltage may go below the ECM's minimum required voltage. Also, the alternator on the other engine may now start charging. This could cause a voltage spike in the engine's electrical system.

In either case, the ECM could shut off. When the voltage returns to the range that the ECM requires, the ECM will reset itself. The engine will now run normally. This ECM shut down usually happens so fast that the engine just appears to have an ignition miss.

Recommendations

Batteries: Boats with multi-engine EFI power packages require each engine be connected to its own battery. This ensures that the engine's Electronic Control Module (ECM) has a stable voltage source.

Battery Switches: Battery switches should always be positioned so each engine is running off its own battery. DO NOT operate engines with switches in **BOTH** or **ALL** position. In an emergency, another engine's battery can be used to start an engine with a dead battery.

Generators: The generator's battery should be considered another engine's battery.

Diagnosing EFI Problems (If Equipped)

NOTE: All references to EFI models apply to EFI and MPI engines.

Your Authorized MerCruiser Dealer has the proper service tools for diagnosing problems on Electronic Fuel Injection (EFI) Systems. The Electronic Control Module (ECM) on these engines has the ability to detect some problems with the system when they occur, and store a “Trouble Code” in the ECM’s memory. This code can then be read later by a service technician using a special diagnostic tool.

Water Separating Fuel Filter

CAUTION

The electric fuel pump and factory installed water separating fuel filter have been carefully designed to function properly together. Do not install additional fuel filters and/or water separating fuel filters between fuel tank and engine.

The installation of additional filters may cause:

- Fuel Vapor Locking
- Difficult Warm-Starting
- Piston Detonation Due to Lean Fuel Mixture
- Poor Driveability

20-Hour Break-In Period

IMPORTANT: The first 20 hours of operation is the engine break-in period. Correct break-in is essential to obtain minimum oil consumption and maximum engine performance. During this break-in period, the following rules must be observed:

- Do not operate below 1500 RPM for extended periods of time for first 10 hours. Shift into gear as soon as possible after starting and advance throttle above 1500 RPM **if conditions permit safe operation.**
- Do not operate at one speed consistently for extended periods.
- Do not exceed 3/4 throttle during first 10 hours. During next 10 hours, occasional operation at full throttle is permissible (5 minutes at a time maximum).
- Avoid full throttle acceleration from IDLE speed.
- Do not operate at full throttle until engine reaches normal operating temperature.
- Frequently check crankcase oil level. Add oil if needed. It is normal for oil consumption to be high during break-in period.

After Break-In Period

To help extend the life of your MerCruiser power package, the following recommendations should be considered;

- Use a propeller that allows the engine to operate at or near the top of the maximum RPM range (See “Specifications” section) when at full throttle with a normal boat load.
- Operation at 3/4 throttle setting or lower is recommended. Refrain from prolonged operation at maximum (full throttle) RPM.

End of First Season Checkup

At the end of the first season of operation, an Authorized MerCruiser Dealer should be contacted to discuss and/or perform various scheduled maintenance items. If you are in an area where the product is operated continuously (year-round operation), you should contact your dealer at the end of the first 100 hours of operation, or once yearly, whichever occurs first.

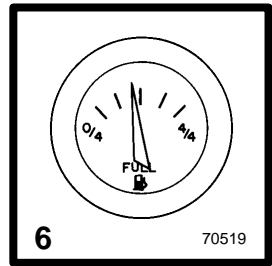
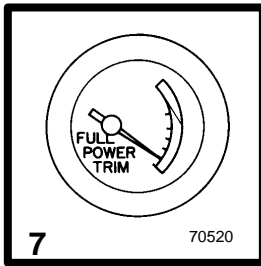
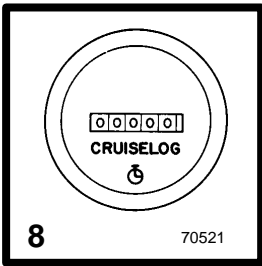
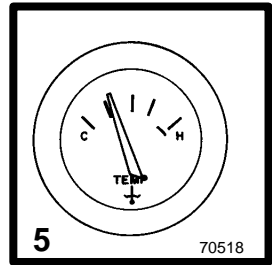
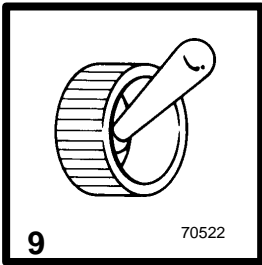
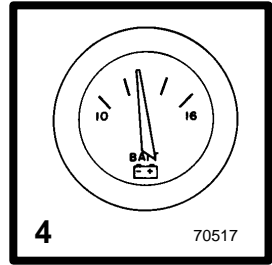
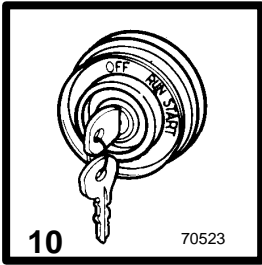
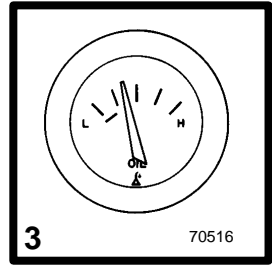
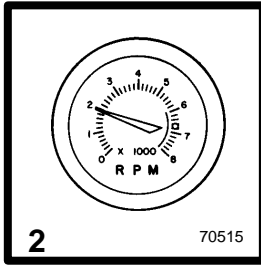
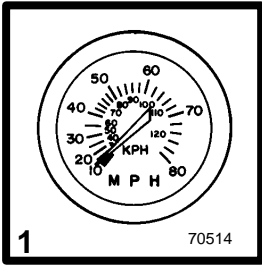

Operation

Instrumentation

The following is a brief explanation of instrumentation typically found on some boats. The owner/operator should be familiar with all instruments and their functions on the boat. Because of the large variety of instrumentation and manufacturers, you should have your boat dealer explain the particular gauges and normal readings that will appear on your style gauges.

- 1** Speedometer: Indicates boat speed.
- 2** Tachometer: Indicates engine RPM.
- 3** Oil Pressure Gauge: Indicates engine oil pressure.
- 4** Battery Meter: Indicates battery voltage.
- 5** Water Temperature Gauge: Indicates engine operating temperature.
- 6** Fuel Gauge: Indicates quantity of fuel in tank.
- 7** Power Trim Gauge: Indicates drive unit angle (trim up/out and down/in).
- 8** Hour Meter: Records engine running time.
- 9** Bilge Blower Switch: Operates bilge blower (If so equipped - see "Starting, Shifting and Stopping" procedure).
- 10** Ignition Switch: Allows operator to start and stop engine.

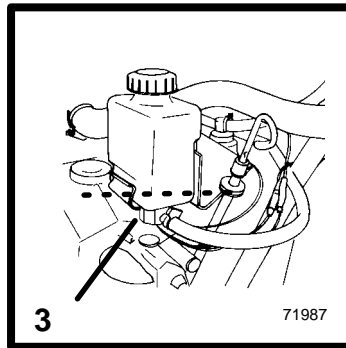
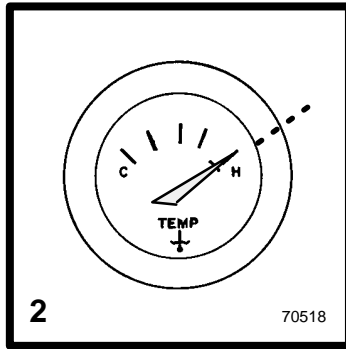
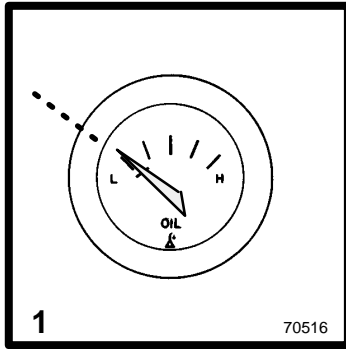

Audio Warning System

Your MerCruiser power package may be equipped with an Audio Warning System.

The audio warning system horn will sound if one of the following occur:

- 1 Engine Oil Pressure Too Low
- 2 Engine Temperature Too Hot
- 3 Drive Oil Level Too Low

NOTE: *To test the system:*

Turn the ignition switch to the ON position without cranking the engine. The horn will sound if the system is working correctly.

CAUTION

Avoid engine damage. Do not operate engine once the buzzer has sounded EXCEPT TO AVOID A HAZARDOUS SITUATION. The Audio Warning System will not protect the engine from damage. It is designed to warn the operator that a problem has occurred.

When the horn sounds with the engine running, stop engine immediately. Investigate cause and correct it, if possible. If cause cannot be determined, consult your Authorized MerCruiser Dealer.

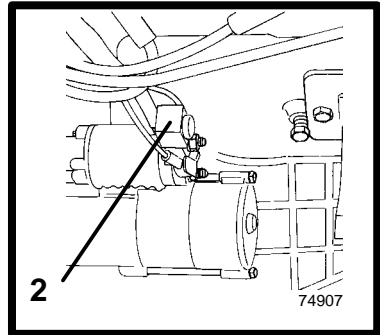
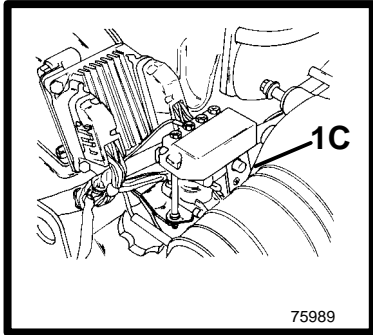
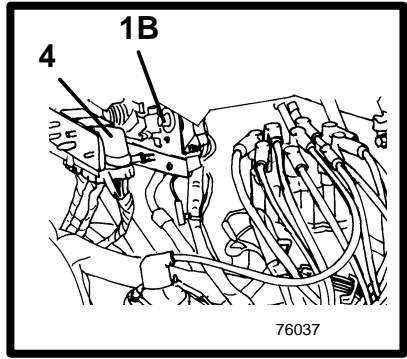
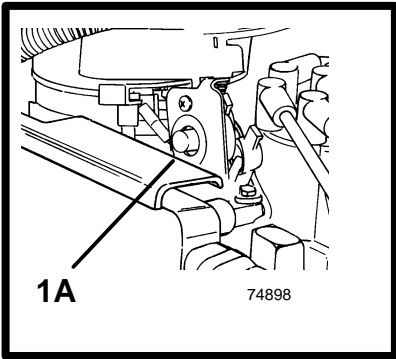

Electrical System Overload Protection

If an electrical overload occurs, a fuse will blow or the circuit breaker will trip open. The cause must be found and corrected before replacing fuse or resetting circuit breaker.

1 A circuit breaker provides protection for engine wiring harness and instrumentation power lead. Reset by pushing RESET button IN.

A Carburetor Models

B EFI Models Except 7.4L MPI

C 7.4L MPI

NOTE: *In an emergency, when engine must be operated and cause for high current draw cannot be located and corrected, turn OFF or disconnect all accessories connected to engine and instrumentation wiring. Reset circuit breaker. If breaker remains open, electrical overload has not been eliminated. Further checks must be made on electrical system.*

2 On EFI Models: A 90 Amp fuse is located on the large post of the starter solenoid. This fuse is designed to protect the engine wiring harness if an electrical overload occurs.

3 On EFI Models: Three fuses are located on the port side of the engine. These fuses control various EFI circuits.

A Fuel Pump Fuse - 15 Amp

B ECM / Injector Fuse - 10 Amp

C ECM / Battery Fuse - 15 Amp

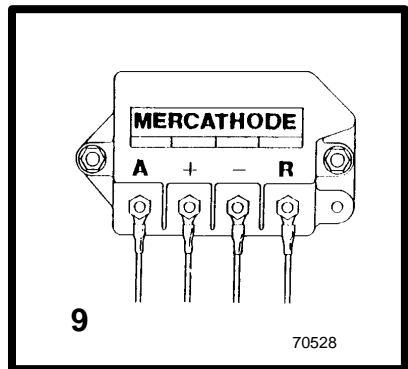
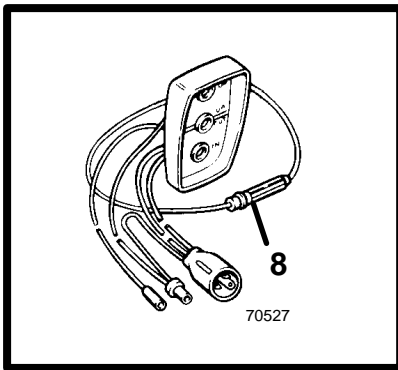
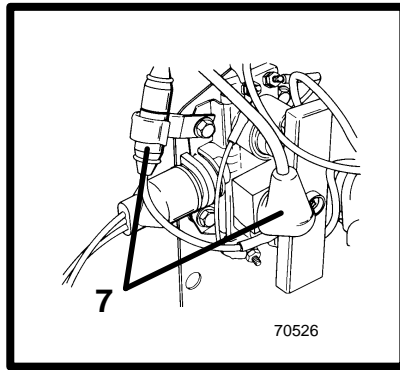
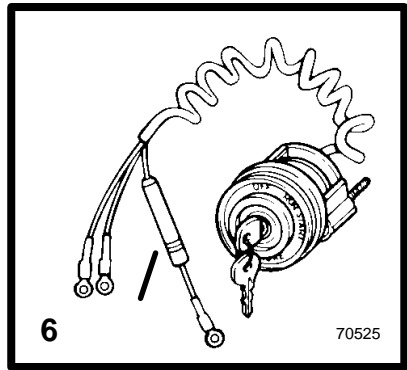
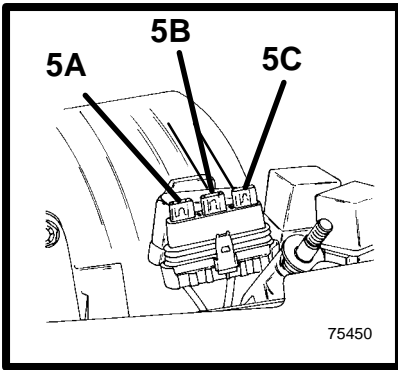

4 7.4L MPI Models: Three fuses are located in a single block on the manifold behind the shift plate. These fuses control various EFI circuits.

A Fuel Pump Fuse - 15 Amp

B ECM / Injector Fuse - 10 Amp

C ECM / Battery Fuse - 15 Amp

5 A 20 amp fuse may be located in ignition switch “I” terminal lead to protect electrical system. Check for blown fuse if key is turned to START and nothing happens (and circuit breaker is not tripped).

6 The Power Trim System is protected from overload by 110 amp fuse and a 20 amp in-line fuse on Power Trim pump.

7 Quicksilver Three-Button Power Trim Control Panel is further protected by a 20 amp in-line fuse.

8 The Quicksilver MerCathode System has a 20 amp in-line fuse is in the wire which connects to positive (+) terminal on controller. If fuse is blown, system will not operate and a loss of corrosion protection will result.

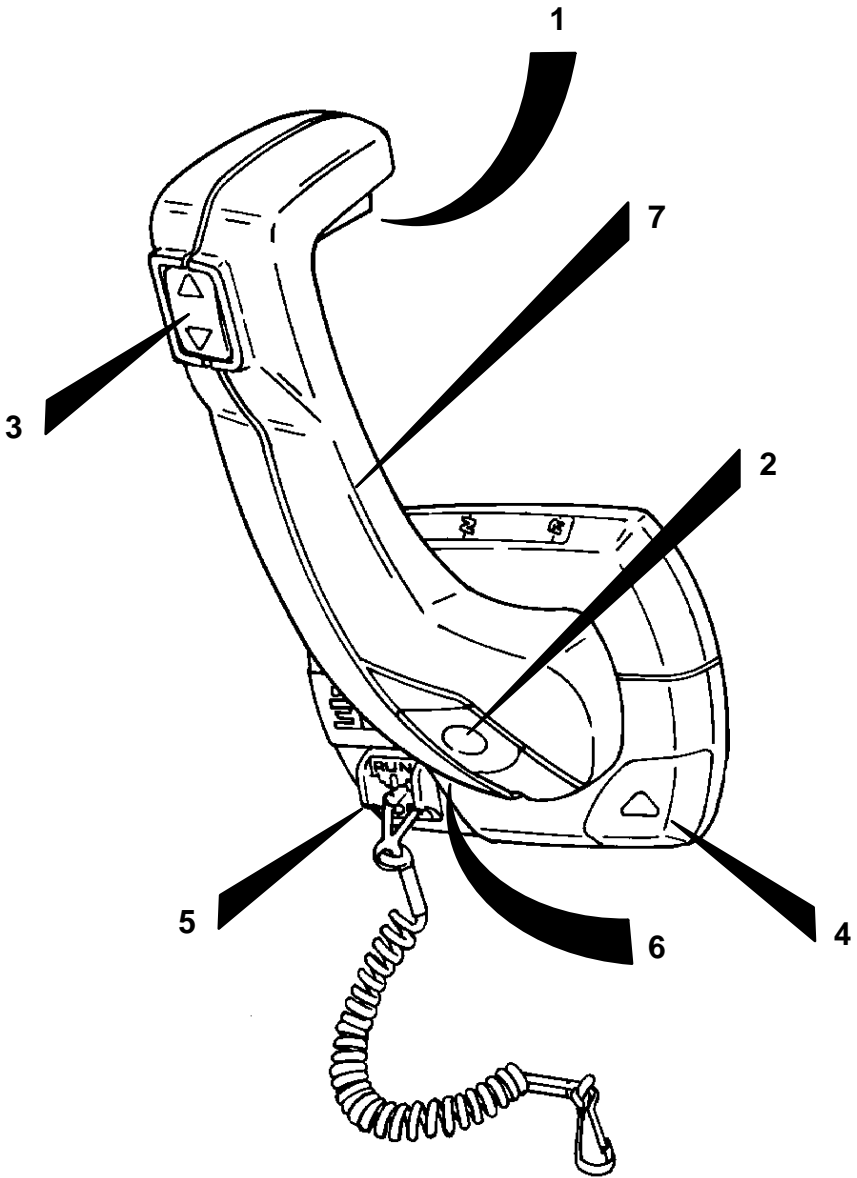

Remote Controls (Panel Mounted)

Your boat may be equipped with one of many Quicksilver® remote controls available. All controls feature an integral safety switch that allows starting engine in NEUTRAL only. Also, all controls may not have all features shown. If boat is equipped with a remote control other than shown, consult your dealer for a description and/or demonstration of the control.

1 Neutral Lock Bar - Prevents accidental shift and throttle engagement. Neutral lock bar must be pulled “Up” to move the control handle out of neutral.

2 Throttle Only Button - Allows engine throttle advancement without shifting the engine. This is done by disengaging the shift mechanism from the control handle. The throttle only button can be depressed only when the remote control handle is in the “Neutral” position, and should only be used to assist in starting the engine.

3 Power Trim Switch - See “Power Trim” for detailed power trim operating procedures.

4 Trailer Switch - Used to raise drive unit for trailering, launching, breaching or shallow water operation. See “Power Trim” for detailed trailer switch operation.

5 Lanyard Stop Switch - Turns ignition “Off” whenever the operator (when attached to the lanyard) moves far enough away from the operator’s position to activate the switch. See “Lanyard Stop Switch” at the front of this manual for safety warning on the use of this switch.

6 Control Handle Tension Adjustment Screw - This screw can be adjusted to “Increase” or “Decrease” the tension on the control handle. This will help prevent “Creep” of the remote control handle. Turn screw “Clockwise” to increase tension and “Counterclockwise” to decrease tension. Adjust to tension desired.

7 Control Handle - Operation of the shift and throttle are controlled by the movement of the control handle. “Push” the control handle forward from “Neutral” with a quick firm motion to the first detent for “Forward” gear. Continue pushing forward to increase speed. Pull the control handle back from “Neutral” with a quick firm motion to the first detent for “Reverse” gear. Continue pushing back to increase speed.

CB183

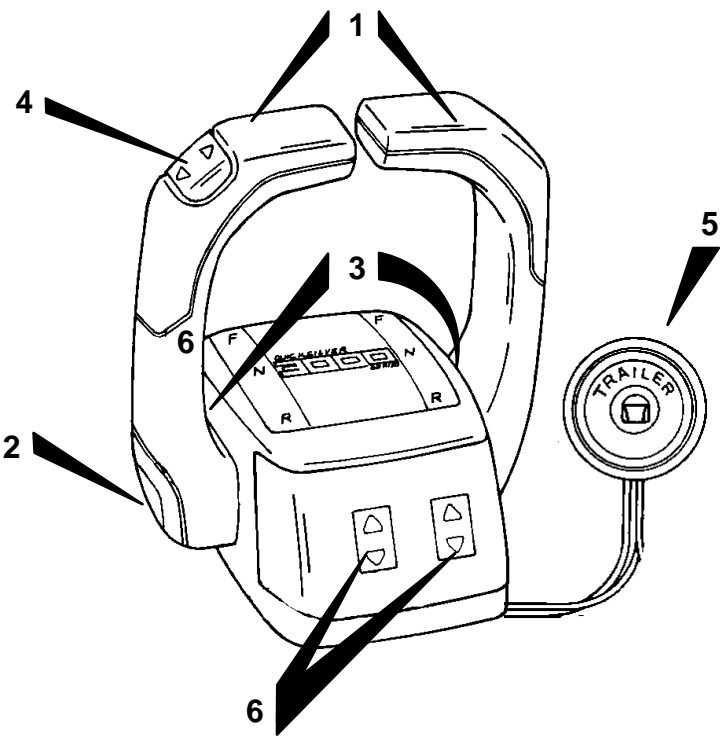
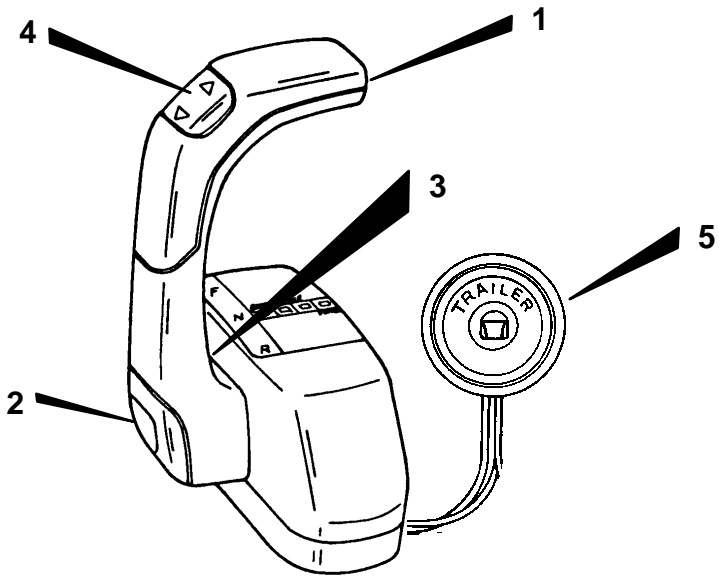

Remote Controls (Console Mounted)

1 Control Handle(s) - Operation of the shift and throttle are controlled by the movement of the control handle. “Push” the control handle forward from “Neutral” with a quick firm motion to the first detent for “Forward” gear. Continue pushing forward to increase speed. Pull the control handle back from “Neutral” with a quick firm motion to the first detent for “Reverse” gear. Continue pushing back to increase speed.

2 Throttle Only Button - Allows engine throttle advancement without shifting the engine. This is done by disengaging the shift mechanism from the control handle. The throttle only button can be depressed only when the remote control handle is in the “Neutral” position, and should only be used to assist in starting the engine.

3 Control Handle Tension Adjustment Screw - This screw can be adjusted to “Increase” or “Decrease” the tension on the control handle (cover must be removed to adjust). This will help prevent “Creep” of the remote control handle. Turn screw “Clockwise” to increase tension and “Counterclockwise” to decrease tension. Adjust to tension desired.

4 Power Trim Switch - See “Power Trim” section for detailed power trim operating procedures.

5 Trailer Switch - Used to raise drive unit for trailering, launching, breaching or shallow water operation. See “Power Trim” for detailed trailer switch operation.

6 Power Trim Adjustment Switches (Used on Three Button Trim Control Only) - See “Power Trim” section for detailed power trim operating procedures.

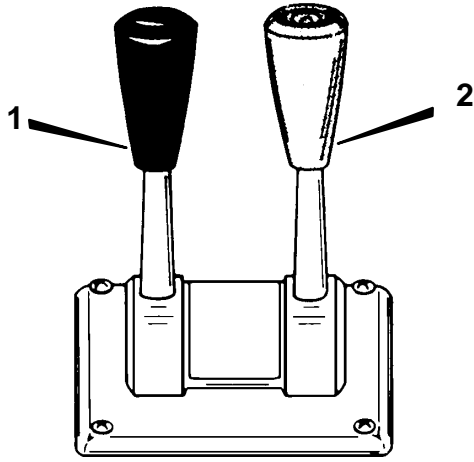

71339

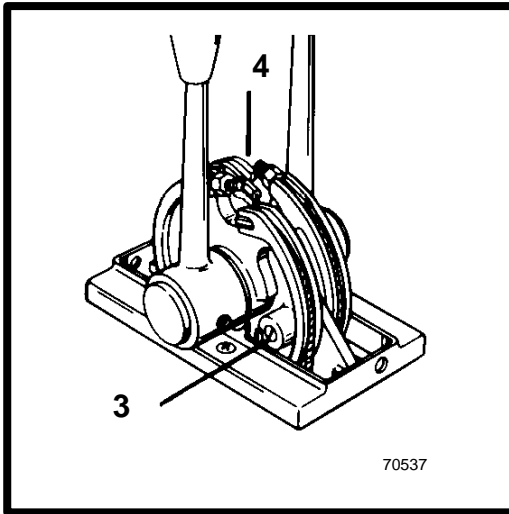

70537

Remote Controls (Two Lever)

1 Shift Lever - shifts unit into gear with full lever movement. Move lever forward to shift to FORWARD gear. Move lever backward to shift to REVERSE gear. Lever in full vertical position shifts to NEUTRAL.

CAUTION

Never shift unit into or out of gear unless throttle lever is at idle RPM.

2 Throttle Lever - allows engine RPM to be increased or decreased.

3 FRICTION Screw - adjusts control handle friction so motor speed can be set and driver does not have to hold handle.

Turn screw clockwise to increase friction. Do not thread screw all the way out.

4 DETENT Screw - controls the effort needed to move control handle out of NEUTRAL. To increase tension, turn screw clockwise; to decrease, turn screw counterclockwise. Do not thread screw all the way out.

IMPORTANT: Boats equipped with dual power packages may have both shift levers on one control and both throttle levers on the other control.

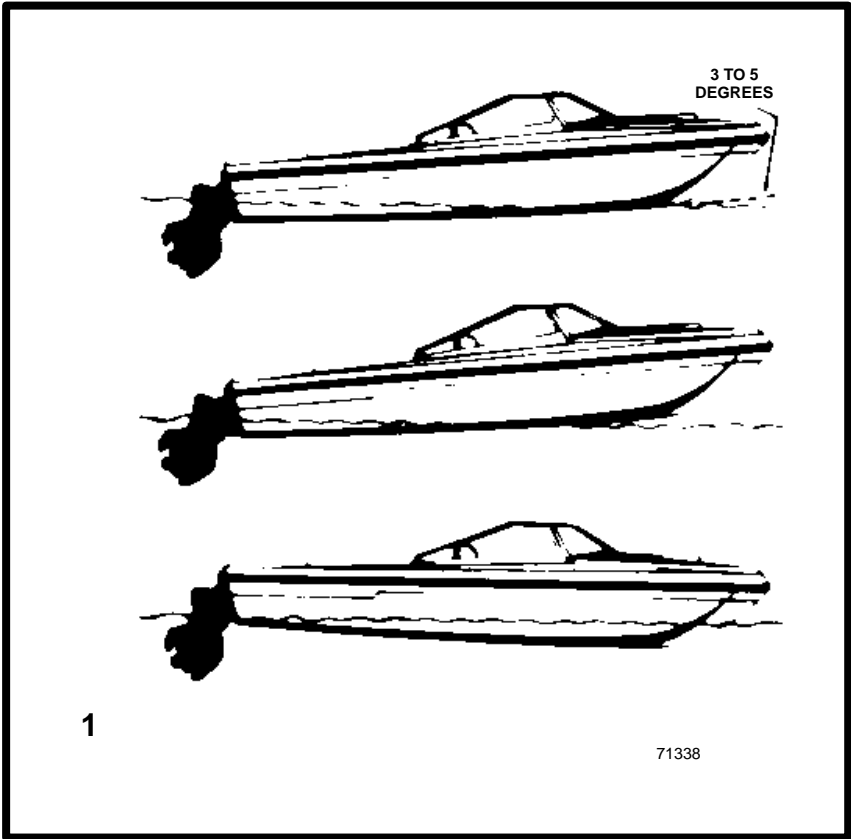

Power Trim

Power Trim allows the operator to adjust the drive angle, while underway, to provide the ideal boat angle for varying load and water conditions. Also, the Power Trim system “Trailing” feature allows the operator to raise and lower the drive unit for trailering, beaching, launching and low speed (below 1200 RPM engine speed), shallow water operation.

CAUTION

Never trim the drive unit UP/OUT using TRAILER switch while boat is underway at engine speeds above 1200 RPM. Use extreme caution when operating with drive unit raised. Severe damage to the drive unit may result if unit is raised beyond the gimbal ring support flanges at engine speeds above 1200 RPM.

1 In most cases, best overall performance is obtained with the drive unit adjusted so the boat bottom will run at a 3° to 5° angle to the water.

Trimming Drive Unit UP/OUT Can:

- Generally increase top speed.
- Increase clearance over submerged objects or a shallow bottom.
- Cause boat to accelerate and plane off slower.
- In excess, cause boat “porpoising” (bouncing) or propeller ventilation.
- Cause engine overheating if trimmed UP/OUT to a point where any cooling water intake holes are above the water line.

Trimming Drive Unit DOWN/IN Can:

- Help the boat accelerate and plane off quicker.
- Generally improve the ride in choppy water.
- In most cases, reduce boat speed.
- If in excess, lower the bow of some boats to a point at which they begin to plow with their bow in the water while on plane. This can result in an unexpected turn in either direction called “bow steering” or “over steering” if any turn is attempted, or if a significant wave is encountered.

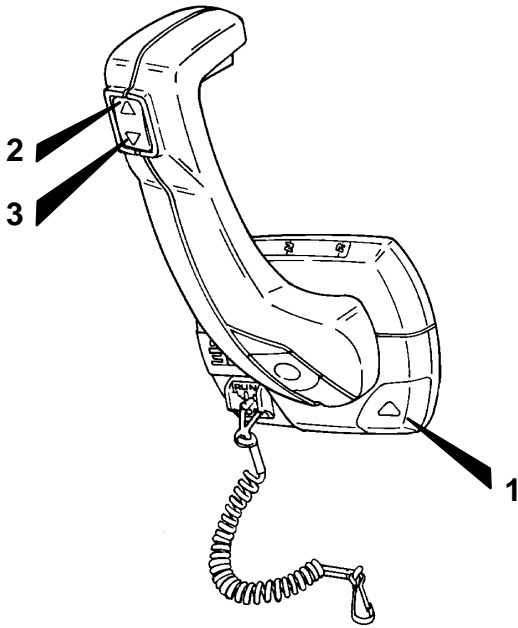

73976

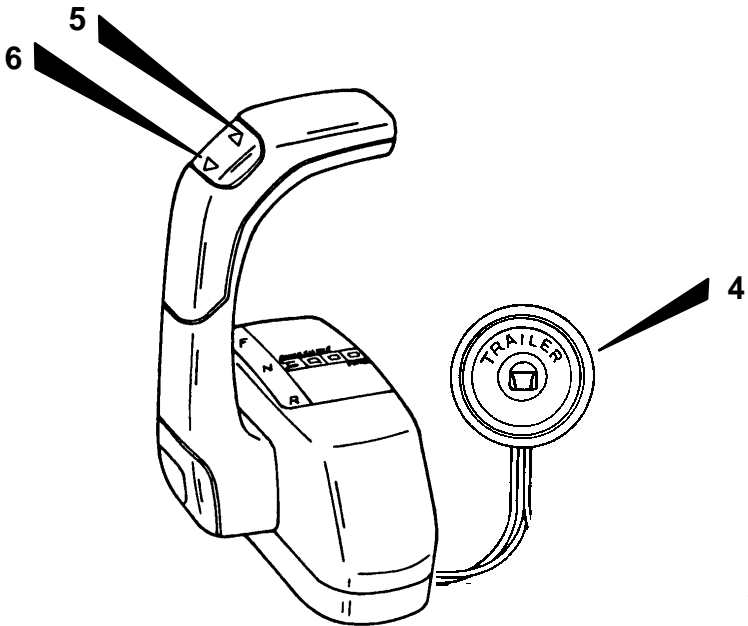

73977

CB188

POWER TRIM OPERATION - PANEL MOUNT REMOTE CONTROL

IMPORTANT: If TRAILER button is held depressed after drive unit reaches end of upward travel, an internal circuit breaker will open and pump will stop. Should this happen, release button and allow motor to cool for about one minute. Circuit breaker will reset and Power Trim operation may be resumed.

- 1** Trailer Position: Press button until drive unit reaches desired height.
- 2** Trim Up/Out: Press UP on Trim switch until drive unit reaches desired trim position.
- 3** Lower Drive Unit: Press DOWN on Trim switch until drive unit reaches desired position.

CB189

POWER TRIM OPERATION - CONSOLE MOUNT REMOTE CONTROL (SINGLE ENGINE VERSION)

- 4** Trailer Position: Press button until drive unit reaches desired height.
- 5** Trim Up/Out: Press UP on Trim switch until drive unit reaches desired trim position.
- 6** Lower Drive Unit: Press DOWN on Trim switch until drive unit reaches desired position.

CB190

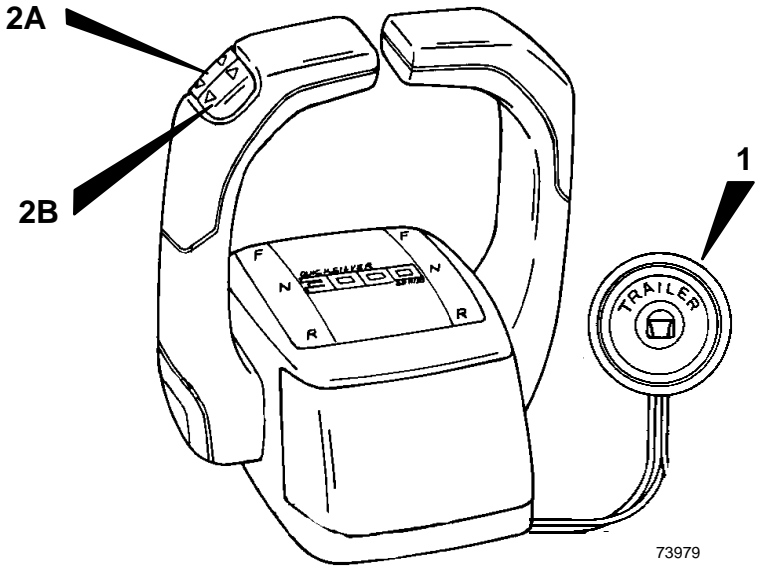

73979

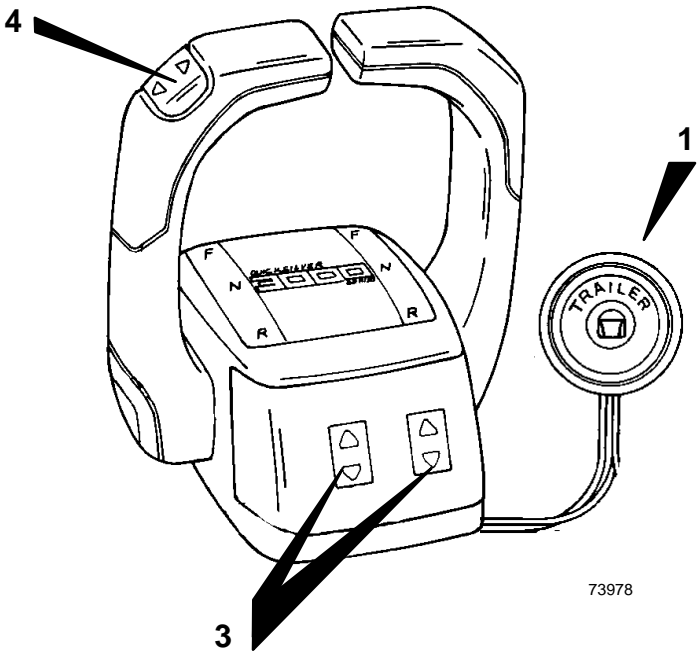

73978

POWER TRIM OPERATION - DUAL ENGINE CONSOLE MOUNT REMOTE CONTROL (TWO BUTTON AND THREE BUTTON VERSIONS)

IMPORTANT: If TRAILER button is held depressed after drive unit reaches end of upward travel, an internal circuit breaker will open and pump will stop. Should this happen, release button and allow motor to cool for about one minute. Circuit breaker will reset and Power Trim operation may be resumed.

⚠ CAUTION

When lowering or raising sterndrives equipped with a dual engine tie bar kit, the sterndrives must be raised or lowered evenly to prevent the tie bar from becoming twisted. Failure to raise or lower sterndrives evenly may result in tie bar or stern-drive damage.

- 1** Trailer Button (Both Versions) - Press button until drive unit reaches desired height for trailering drive units.
- 2** Two Button Trim Control (Dual Buttons in Handle) - used to control both drive units from the handle. Press UP on button(s) to trim drive unit UP/OUT. Press down on button(s) to trim drive unit DOWN/IN.
 - A** Forward Trim Button - Used to trim the port drive unit.
 - B** Rear Trim Button - Used to trim the starboard drive unit.
- 3** Three Button Trim Control (Trim Adjustment Switches) - With a single integral trim button in the handle to control two drive units simultaneously, these two switches control the fine tune adjustment of each drive unit. Using these Fine Tune Switches, set each drive unit to the desired trim angle. Then use the single trim switch in the handle to control the trim of both drive units simultaneously.
- 4** Three Button Trim Control (Single Trim Switch in Handle) - used to trim both drives simultaneously after drives have been fine-tuned as described above.

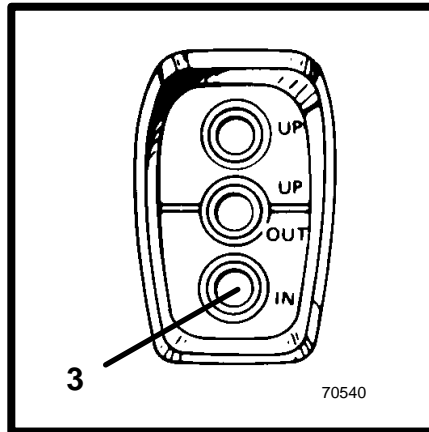
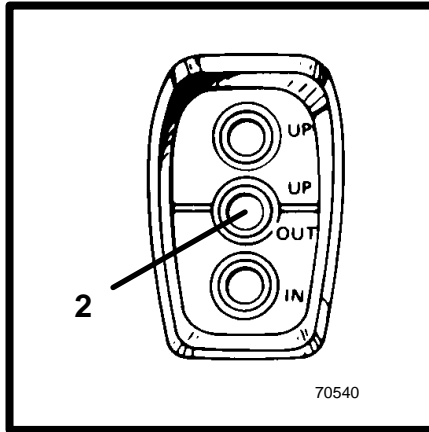
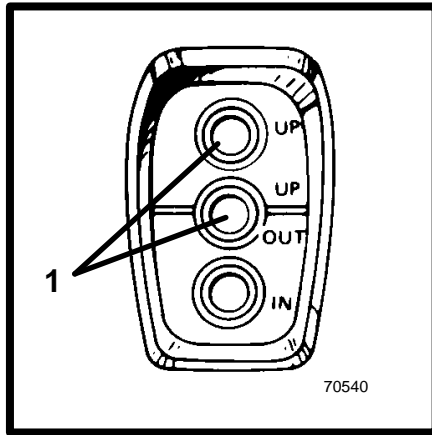

**POWER TRIM OPERATION - THREE BUTTON TRIM PANEL
(USED ON MODELS WITH TWO-LEVER CONTROL)**

IMPORTANT: If TRAILER button is held depressed after drive unit reaches end of upward travel, an internal circuit breaker will open and pump will stop. Should this happen, release button(s) and allow motor to cool for about one minute. Circuit breaker will reset and Power Trim operation may be resumed.

- 1** Trailer Position: Simultaneously press the UP button (top) along with the UP/OUT button (center) until drive unit reaches desired trailer position.
- 2** Trim Drive Unit UP/OUT: Press center UP/OUT button until drive unit reaches desired trim position.
- 3** Trim Drive Unit IN/DOWN: Press IN button until drive unit reaches desired trim position.

Starting, Shifting And Stopping

WARNING

Before starting engine, operate bilge blower for at least five minutes to remove any explosive fumes from engine compartment. If boat is not equipped with a bilge blower, open engine hatch and leave open while starting engine.

IMPORTANT: Observe the following:

- **Do not start engine without water being supplied to seawater pickup pump (to prevent pump or engine damage).**
- **Do not operate starter motor continuously for more than 30 seconds.**
- **On Carbureted Engines: When engine starts, quickly reduce throttle setting to avoid exceeding 1500 RPM.**
- **Never shift drive unit unless engine is at Idle RPM.**

Perform the following as appropriate:

- 1** Check all items listed in OPERATION CHART.
 - 2** Perform any other necessary checks, as indicated by your dealer, or specified in your boat owner's manual.
 - 3** Place drive unit in full down/in position.
 - 4** Place control handle in NEUTRAL.
 - 5** Refer to A or B as appropriate for your model.
- A** Carbureted Engine - Push the THROTTLE ONLY button and position throttle setting as follows:
- COLD ENGINE** - Move control/throttle lever to full throttle, then return to about 1/4 throttle. In extreme cold it may be necessary to pump lever more than once.
- WARM ENGINE** - Move control/throttle lever to 1/4 throttle position.
- FLOODED ENGINE** - Move control/throttle lever to full throttle. Be prepared to decrease engine speed to 1000-1500 RPM as soon as engine starts.

B EFI Engine - Position throttle setting as follows:

COLD ENGINE - Leave in neutral/idle speed position.

WARM ENGINE - Leave in neutral/idle speed position.

FLOODED ENGINE - Turn ignition switch to ON position. Push the THROTTLE ONLY button and place the throttle lever at 50% position. Attempt to start engine. As soon as engine starts, return throttle to the idle position.

6 Turn ignition key to START. Release key when engine starts and allow switch to return to RUN position.

7 Carbureted Engines - Move control/throttle lever back to decrease engine RPM to 1000-1500 RPM if necessary.

8 Check oil pressure gauge immediately after engine starts. If oil pressure is not within specified range (see SPECIFICATIONS), stop engine immediately and determine cause.

9 If engine is cold, run engine for 1 or 2 minutes at fast idle (1000-1500 RPM).

10 After engine has warmed up, check water temperature gauge to ensure that engine temperature is not abnormally high. If it is, stop engine immediately and determine cause.

11 Be sure charging system is functioning correctly.

12 Observe power package for fuel, oil, water and exhaust leaks.

13 To shift drive unit, return control/throttle lever to NEUTRAL. Move control/shift lever with a firm, quick motion forward to shift to FORWARD gear, or backward to shift to REVERSE. After shifting drive unit, advance throttle to desired setting.

14 Move control/shift lever to NEUTRAL and allow engine to drop to IDLE speed. If engine has been run at high speed for a long period of time, allow engine to cool by running at IDLE speed for 3 to 5 minutes.

15 Turn ignition key to OFF.

⚠ CAUTION

To avoid possible ingestion of water that can damage engine components:

- Do not turn the ignition key off when the engine is running above idle speed.
- Do not use the lanyard stop switch to shut off the engine above idle speed.
- When coming off plane, if a large following wave may roll over the boat's transom, apply a short, light burst of throttle to minimize the wave action against the stern of the boat.
- Do not come off plane quickly, shift into reverse and shut off engine.

CB575

IMPORTANT: Avoid stopping engine if the drive unit is in gear. If engine does stop with drive unit in gear, refer to the following procedure:

- 1 Push and pull repeatedly on remote control handle until handle returns to the neutral detent position. This may take several tries if the power package was operating above idle RPM when the engine stopped.
- 2 After handle returns to the neutral detent position, resume normal starting procedures.

Operation Chart

BEFORE STARTING	AFTER STARTING	WHILE UNDERWAY	AFTER STOPPING
Open engine hatch.	Observe all gauges to check condition of engine. If not normal, stop engine.	Observe all gauges to check condition of engine. If not normal, stop engine.	Turn ignition key to OFF.
Turn battery switch ON, if so equipped.	Check for fuel, oil, water, fluid and exhaust leaks, etc.		Turn battery switch OFF, if so equipped.
Operate bilge blowers, if so equipped.	Check shift and throttle control operation.		Close fuel valve.
Open fuel shutoff valve.	Check steering operation.		Close seacock, if so equipped.
Open seacock, if so equipped.			Flush cooling system if in saltwater.
Place drive unit if full DOWN/IN position.			
Perform all other checks specified by your dealer and/or boat builder.			

Specifications

Fuel Recommendations

IMPORTANT: Use of improper gasoline can damage your engine seriously. Engine damage resulting from use of improper gasoline is considered misuse of engine, and damage caused thereby will not be covered under the limited warranty.

FUEL RATINGS

MerCruiser engines will operate satisfactorily when using a major brand of unleaded gasoline as follows:

USA and Canada - having a posted pump Octane Rating of 87 (R+M)/2 minimum. Premium gasoline [92 (R+M)/2 Octane] is also acceptable. DO NOT use leaded gasoline.

Outside USA and Canada - having a posted pump Octane Rating of 90 RON minimum. Premium gasoline (98 RON) is also acceptable. If unleaded gasoline is not available, use a major brand of leaded gasoline.

CA291

USING REFORMULATED (OXYGENATED) GASOLINES (USA ONLY)

This type of gasoline is required in certain areas of the USA. The two types of “oxygenates” used in these fuels is Alcohol (Ethanol) or Ether (MTBE or ETBE). If Ethanol is the “oxygenate” that is used in the gasoline in your area, refer to “Gasolines Containing Alcohol” also.

These “Reformulated Gasolines” are acceptable for use in your MerCruiser engine.

CA618

GASOLINES CONTAINING ALCOHOL

If the gasoline in your area contains either “methanol” (methyl alcohol) or “ethanol” (ethyl alcohol), you should be aware of certain adverse effects that can occur. These adverse effects are more severe with “methanol.” Increasing the percentage of alcohol in the fuel can also worsen these adverse effects.

Some of these adverse effects are caused because the alcohol in the gasoline can absorb moisture from the air, resulting in a separation of the water/alcohol from the gasoline in the fuel tank.

The fuel system components on your MerCruiser engine will withstand up to 10% alcohol content in the gasoline. We do not know what percentage your boat's fuel system will withstand. Contact your boat manufacturer for specific recommendations on the boats fuel system components (fuel tanks, fuel lines, and fittings). Be aware that gasolines containing alcohol may cause increased:

- Corrosion of metal parts.
- Deterioration of rubber or plastic parts.
- Fuel permeation through rubber fuel lines.
- Starting and operating difficulties.

 **WARNING**

FIRE AND EXPLOSION HAZARD: Fuel leakage from any part of fuel system can be a fire and explosion hazard which can cause serious bodily injury or death. Careful periodic inspection of entire fuel system is mandatory, particularly after storage. All fuel components including fuel tanks, whether plastic metal or fiberglass, fuel lines, fittings, fuel filters and carburetors/fuel injection components should be inspected for leakage, softening, hardening, swelling or corrosion. Any sign of leakage or deterioration requires replacement before further engine operation.

Because of possible adverse effects of alcohol in gasoline, it is recommended that only alcohol-free gasoline be used where possible. If only fuel containing alcohol is available, or if the presence of alcohol is unknown, increased inspection frequency for leaks and abnormalities is required.

IMPORTANT: When operating a MerCruiser engine on gasoline containing alcohol, storage of gasoline in the fuel tank for long periods should be avoided. Long periods of storage, common to boats, create unique problems. In cars alcohol-blend fuels normally are consumed before they can absorb enough moisture to cause trouble, but boats often sit idle long enough for phase separation to take place. In addition, internal corrosion may take place during storage if alcohol has washed protective oil films from internal components.

FUEL SYSTEM ADDITIVES (V6 AND 5.0L/305 CID MODELS)

To maximize the life of valves and valve seats on your MerCruiser engine, use Quicksilver Valve Lubricant (92-826259A12) regularly.

Crankcase Oil

To help obtain optimum engine performance and to provide maximum protection, we strongly recommend the use of Quicksilver 4-Cycle 25W-40 Marine Engine Oil. This oil is a special blend of 25-weight and 40-weight oils for marine engines. If not available, a good grade, straight weight, detergent automotive oil of correct viscosity, with an API classification of SH,CF/CF-2, may be used.

In those areas where Quicksilver 4-Cycle 25W-40 Marine Engine Oil or a recommended straight weight oil are not available, a multi-viscosity 20W-40 or, as a second but less preferable choice, 20W-50, with API service ratings of SH, CF/CF-2 may be used.

IMPORTANT: The use of non-detergent oils, multi-viscosity oils (other than Quicksilver 25W-40 or a good quality 20W-40 or 20W-50), synthetic oils, low quality oils or oils that contain solid additives are specifically not recommended.

The chart below is a guide to crankcase oil selection. The oil filter should always be changed when changing engine oil.

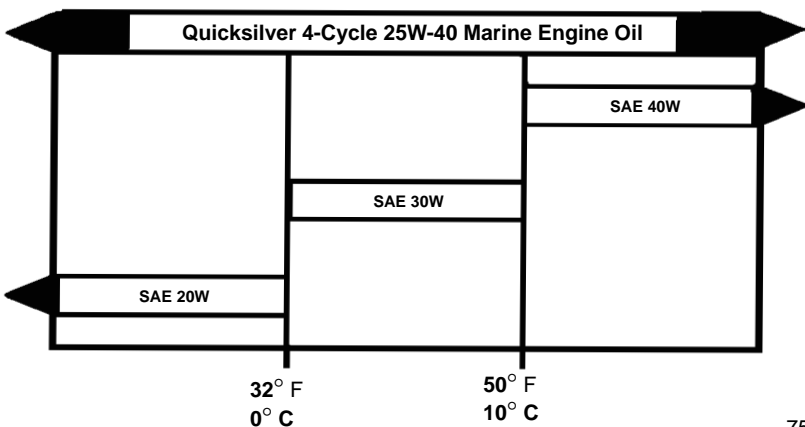

AIR TEMPERATURE

Engine Specifications (V-6 Models)

Models	4.3L	4.3LH	4.3L EFI
Propshaft Horsepower (BSO/SAV Rating)	190 ¹	205 ¹ (190 ²)	210 ¹ (188 ²)
Propshaft Kilowatts (BSO/SAV Rating)	142 ¹	153 (142 ²)	157 ¹ (140 ²)
Displacement	262 cid (4.3L)		
Maximum RPM @ W.O.T ³	4400-4800 RPM		
Idle RPM in NEUTRAL	650 RPM ⁵	600 RPM ⁶	
Oil Pressure @ 2000 RPM	30-70 psi (207-483 kPa)		
Min. Oil Pressure @ Idle	4 psi (28 kPa)		
Thermostat	160° F (71° C)		
Timing @ Idle RPM ⁴	10 ° BTDC	8° BTDC	
Firing Order	1-6-5-4-3-2		
Electrical System	12-Volt Negative (-) Ground		
Alternator Rating	55 Amps	65 Amps	
Recommended Battery Rating	Min 375 cca/ 475 mca/90 Ah	Min 550 cca/ 700 mca/120 Ah	

¹ Power Rated in Accordance with NMMA (National Marine Manufacturers' Association) rating procedures.

² Power Rated in Accordance with BSO/SAV rating procedures. This rating procedure is used to certify that the engine complies with "Stage 1" Bodensee and Swiss Regulations. Horsepower differences shown result from differences in test RPM, allowable test tolerances, and/or installation of special kit components.

³ Measured using an accurate service tachometer with engine at normal operating temperature.

⁴ A special procedure must be followed to check or adjust timing. Consult your Authorized MerCruiser Dealer before attempting this procedure.

⁵ A special procedure must be followed to adjust idle RPM. Consult your Authorized MerCruiser Dealer before attempting this procedure.

⁶Idle speed on EFI models is not adjustable.

Engine Specifications (V-8 Models)

Models	5.0L	5.0L EFI
Propshaft Horsepower (BSO/SAV Rating)	220 ¹	240 ¹
Propshaft Kilowatts (BSO/SAV Rating)	164 ¹	179 ¹
Displacement	305 cid (5.0L)	
Maximum RPM @ W.O.T ³	4400-4800 RPM	
Idle RPM in NEUTRAL ³	650 RPM ⁵	600 RPM ⁶
Oil Pressure @ 2000 RPM	30-60 psi (207-414 kPa)	
Min. Oil Pressure @ Idle	4 psi (28 kPa)	
Thermostat	160° F (71° C)	
Timing @ Idle RPM ⁴	10° BTDC	8° BTDC
Firing Order	1-8-4-3-6-5-7-2	
Electrical System	12-Volt Negative (-) Ground	
Alternator Rating	55 Amps	65 Amps
Recommended Battery Rating	Min 375 cca/475 mca/90 Ah	Minimum 550 cca/700 mca/120 Ah

¹ Power Rated in Accordance with NMMA (National Marine Manufacturers' Association) rating procedures.

² Power Rated in Accordance with BSO/SAV rating procedures. This rating procedure is used to certify that the engine complies with "Stage 1" Bodensee and Swiss Regulations. Horsepower differences shown result from differences in test RPM, allowable test tolerances, and/or installation of special kit components.

³ Measured using an accurate service tachometer with engine at normal operating temperature.

⁴ A special procedure must be followed to check or adjust timing. Consult your Authorized MerCruiser Dealer before attempting this procedure.

⁵ A special procedure must be followed to adjust idle RPM. Consult your Authorized MerCruiser Dealer before attempting this procedure.

⁶ Idle speed on EFI models is not adjustable.

Engine Specifications (V-8 Models)

Models	5.7L	5.7L EFI	350 Mag MPI
Propshaft Horsepower (BSO/SAV Rating)	250 ¹	260 ¹ (233 ²)	300 ¹ (259 ²)
Propshaft Kilowatts (BSO/SAV Rating)	186 ¹	194 ¹ (174 ²)	224 ¹ (193 ²)
Displacement	350 cid (5.7L)		
Maximum RPM @ W.O.T ³	4400-4800 RPM		4600-5000 RPM
Idle RPM in NEUTRAL ³	650 RPM ⁵	600 RPM ⁶	
Oil Pressure @ 2000 RPM	30-60 psi (207-414 kPa)		
Min. Oil Pressure @ Idle	4 psi (28 kPa)		
Thermostat	160° F (71° C)		
Timing @ Idle RPM ⁴	10° BTDC	8° BTDC	
Firing Order	1-8-4-3-6-5-7-2		
Electrical System	12-Volt Negative (-) Ground		
Alternator Rating	55 Amps	65 Amps	
Recommended Battery Rating	Minimum 375 cca/475 mca/90 Ah	Minimum 550 cca/ 700 mca/120 Ah	

¹ Power Rated in Accordance with NMMA (National Marine Manufacturers' Association) rating procedures.

² Power Rated in Accordance with BSO/SAV rating procedures. This rating procedure is used to certify that the engine complies with "Stage 1" Bodensee and Swiss Regulations. Horsepower differences shown result from differences in test RPM, allowable test tolerances, and/or installation of special kit components.

³ Measured using an accurate service tachometer with engine at normal operating temperature.

⁴ A special procedure must be followed to check or adjust timing. Consult your Authorized MerCruiser Dealer before attempting this procedure.

⁵ A special procedure must be followed to adjust idle RPM. Consult your Authorized MerCruiser Dealer before attempting this procedure.

⁶ Idle speed on EFI models is not adjustable.

Engine Specifications (V-8 Models)

Models	7.4L MPI	454 Mag MPI
Propshaft Horsepower (BSO/SAV Rating)	310 ¹ (275 ²)	385 ¹
Propshaft Kilowatts (BSO/SAV Rating)	231 ¹ (205 ²)	287 ¹
Displacement	454 cid (7.4L)	
Maximum RPM @ W.O.T ³	4200-4600 RPM	4600-5000 RPM
Idle RPM in NEUTRAL ³	600 RPM ⁶	
Oil Pressure @ 2000 RPM	30-70 psi (207-483 kPa)	
Min. Oil Pressure @ Idle	4 psi (28 kPa)	
Thermostat	160° F (71° C)	
Timing @ Idle RPM ⁴	8° BTDC	
Firing Order	1-8-4-3-6-5-7-2	
Electrical System	12-Volt Negative (-) Ground	
Alternator Rating	65 Amps	
Recommended Battery Rating	Minimum 650 cca/825 mca/150 Ah	

¹ Power Rated in Accordance with NMMA (National Marine Manufacturers' Association) rating procedures.

² Power Rated in Accordance with BSO/SAV rating procedures. This rating procedure is used to certify that the engine complies with "Stage 1" Bodensee and Swiss Regulations. Horsepower differences shown result from differences in test RPM, allowable test tolerances, and/or installation of special kit components.

³ Measured using an accurate service tachometer with engine at normal operating temperature.

⁴ A special procedure must be followed to check or adjust timing. Consult your Authorized MerCruiser Dealer before attempting this procedure.

⁶ Idle speed on EFI models is not adjustable.

Engine Specifications (V-8 Models)

Models	502 Mag MPI
Propshaft Horsepower (BSO/SAV Rating)	415 ¹
Propshaft Kilowatts (BSO/SAV Rating)	309 ¹
Displacement	502 cid (8.2L)
Maximum RPM @ W.O.T ³	4600-5000 RPM
Idle RPM in NEUTRAL ³	600 RPM
Oil Pressure @ 2000 RPM	30-70 psi (207-483 kPa)
Min. Oil Pressure @ Idle	4 psi (28 kPa)
Thermostat	160° F (71° C)
Timing @ Idle RPM ⁴	8° BTDC
Firing Order	1-8-4-3-6-5-7-2
Electrical System	12-Volt Negative (-) Ground
Alternator Rating	65 Amps
Recommended Battery Rating	Minimum 650 cca/825 mca/150 Ah

¹ Power Rated in Accordance with NMMA (National Marine Manufacturers' Association) rating procedures.

³ Measured using an accurate service tachometer with engine at normal operating temperature.

⁴ A special procedure must be followed to check or adjust timing. Consult your Authorized MerCruiser Dealer before attempting this procedure.

⁶ Idle speed on EFI models is not adjustable.

Maintenance

WARNING

Always disconnect battery cables from battery before working around electrical system components to prevent injury to yourself or damage to electrical system should a wire be accidentally shorted.

IMPORTANT: Refer to **MAINTENANCE CHART** for complete listing of all scheduled maintenance to be performed. Some listings can be done by owner/operator, while others should be performed by an Authorized MerCruiser Dealer. Before attempting maintenance or repair procedures not covered in this manual, it is recommended that a MerCruiser Maintenance Procedures Manual or Service Manual be purchased and read thoroughly.

***NOTE:** Maintenance points are color coded for ease of identification. See the decal on engine for identification.*

Maintenance Aids

- 1** Power Steering System - Quicksilver Power Trim and Steering Fluid or Dexron III automatic transmission fluid (ATF).
- 2** Propeller Shaft - Quicksilver Special Lubricant 101.
- 3** Sterndrive Unit - Quicksilver High Performance Gear Lube.
- 4** All Exterior Surfaces - Quicksilver Primer and Spray Paint and Quicksilver Corrosion Guard.
- 5** Power Trim System - Quicksilver Power Trim and Steering Fluid, or SAE 10W-30 motor oil.
- 6** Crankcase Oil - Quicksilver 4-Cycle Marine Engine Oil (Refer to SPECIFICATIONS for alternatives and oil recommendations for varying ambient temperatures.)
- 7** Closed Cooling System Coolant - Extended Life Ethylene Glycol 5/100 Antifreeze/Coolant mixed 50/50 with purified water. If this is not available, use a 50/50 mixture of ethylene glycol antifreeze and tap water. Areas where temperatures generally do not go below 32° F (0° C), rust inhibitor and tap water is acceptable.

Maintenance Chart

SCHEDULED MAINTENANCE THAT CAN BE PERFORMED BY OWNER/OPERATOR

NOTE: Only perform maintenance which applies to your particular power package.

Task	Interval
Engine Crankcase Oil - Check level	Weekly
Closed Cooling Coolant - Check level	
Power Steering Fluid - Check level	
Sterndrive Unit Oil - Check level	
Battery - Check level and inspect for damage	
Power Trim Pump Oil - Check level	
Anodes - Inspect for erosion	
Gear Housing Water Pickups - Check for marine growth or debris	

**SCHEDULED MAINTENANCE THAT CAN BE PERFORMED
BY OWNER/OPERATOR**

NOTE: Only perform maintenance which applies to your particular power package.

Task	Interval
Drive Belt - Inspect condition and check tension	Every 100 hours of operation or 120 days, whichever occurs first.
Propeller Shaft - Lubricate	Saltwater Use: Every 50 hours of operation or 60 days, whichever occurs first. Freshwater Use: Every 100 hours of operation or 120 days, whichever occurs first.
Power Package - Exterior Surfaces - Spray with rust preventative	
Power Package Exterior Surfaces - Clean and paint	Once a year
Cooling System - Flush seawater section	Saltwater Use: After every use.

**SCHEDULED MAINTENANCE THAT SHOULD BE PERFORMED
BY A DEALER**

NOTE: Only perform maintenance which applies to your particular power package.

Task	Interval
Seawater Pickup Pump - Disassemble and inspect.	Whenever insufficient seawater flow is suspected. (If operating temperature exceeds normal range.)
Crankcase Oil and Filter - Change.	End of first boating season and thereafter, every 100 hours of operation or once yearly, whichever occurs first.
Ignition system - Clean and inspect condition.	
Flame Arrestor and Crankcase Ventilation Hose - Clean and inspect.	
Positive Crankcase Ventilation (PCV) Valve (If Equipped) - Change.	
Sterndrive Unit Oil - Change.	
Gimbal Ring Clamping Screws - Retorque to 50-55 ft. lb. (68-74 N·m).	
Rear Engine Mounts - Torque to 35-40 ft. lb. (47-54 N·m).	
Gimbal Bearing - Lubricate.	
Cooling System - Clean and inspect.	

**SCHEDULED MAINTENANCE THAT SHOULD BE PERFORMED
BY A DEALER**

NOTE: *Only perform maintenance which applies to your particular power package.*

Task	Interval
Engine Alignment - Check.	End of first boating season and thereafter, every 100 hours of operation or once yearly, whichever occurs first.
Engine Coupling Universal Joint Shaft Splines - Lubricate.	
Steering System - Lubricate and inspect for loose, damaged or missing parts.	
Electrical System - Check for loose or damaged wiring.	
Cooling System Hoses and Clamps - Inspect for damage and deterioration. Check clamps for tightness.	
Closed Cooling System Pressure Cap - Clean, inspect and test.	
Continuity Circuit - Check components for loose connections, broken or frayed wires.	
Shift and Throttle Cable and Linkage - Lubricate and inspect for loose, damaged or missing parts.	
Engine Exhaust System - Inspect externally for damage, deterioration and restrictions. Check for tightness.	
Ignition System - Check timing and adjust as needed.	

**SCHEDULED MAINTENANCE THAT SHOULD BE PERFORMED
BY A DEALER**

NOTE: Only perform maintenance which applies to your particular power package.

Task	Interval
Steering Head and Remote Control - Inspect and lubricate.	End of first boating season and thereafter, every 100 hours of operation or once yearly, whichever occurs first.
Carburetor (If Equipped) - Inspect and adjust.	
Throttle Body (EFI Models) - Inspect.	
Fuel Filter - Replace.	Once a Year
Quicksilver MerCathode System - Test output.	
Closed Cooling Coolant - Test for alkalinity.	
Heat Exchanger - Clean seawater section.	
Drive Unit Bellows and Clamps - Inspect.	
Universal Joint Cross Bearings- Inspect.	End of first boating season and thereafter, every 200 hours of operation or once yearly, whichever occurs first.
Closed Cooling Coolant - Replace.	Every Five Years ¹

¹Only if Extended Life 5/100 Ethylene Glycol Antifreeze/Coolant is used. If any non-compatible coolant is added to this coolant, coolant must be changed every 2 years or 400 hours, whichever occurs first. All coolants other than Extended Life 5/100 Ethylene Glycol Antifreeze/Coolant must be changed every 2 years or 400 hours, whichever occurs first.

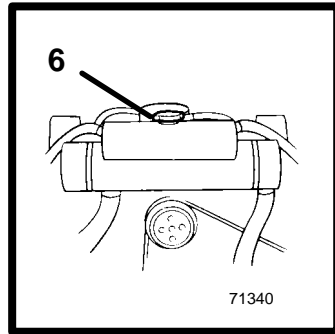
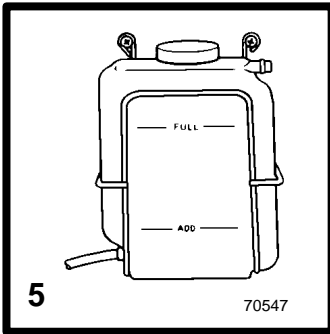
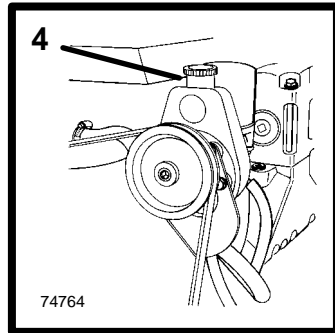
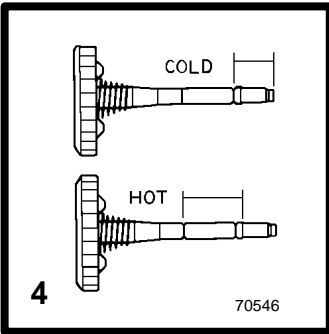
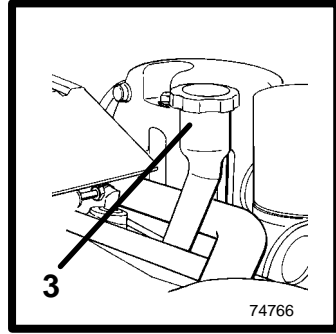
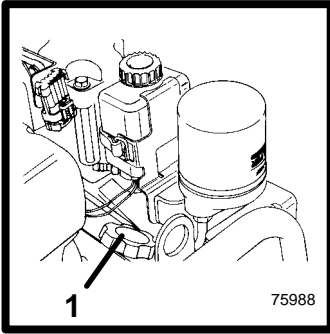

Checking Fluid Levels

CHECKING CRANKCASE OIL

Stop engine. Allow approximately five minutes for oil to drain into oil pan. Boat must be at rest in water.

- 1 Remove dipstick. Wipe clean and reinstall fully into dipstick tube.
- 2 Remove dipstick and observe oil level. Oil level must be between FULL and ADD. If oil level is below ADD:
- 3 Remove oil filler cap. Add specified oil to bring level up to, but not over, FULL mark on dipstick.

IMPORTANT: Do not overfill crankcase oil.

CHECKING POWER STEERING PUMP FLUID

Stop engine and position drive unit straight back.

- 4 Remove FILLCAP/DIPSTICK and observe level. Add specified fluid if required. Reinstall FILLCAP/DIPSTICK.

IMPORTANT: If fluid is not visible in pump, contact your Authorized MerCruiser Dealer.

CHECKING ENGINE COOLANT - CLOSED COOLED MODELS ONLY

WARNING

Avoid serious injury from burns. Do not remove coolant cap when engine is hot. Coolant may discharge violently.

- 5 Check coolant level in coolant recovery bottle. Add specified coolant as required.
- 6 Periodically remove cap from coolant reservoir to ensure that coolant recovery system is functioning properly. Coolant level must be at top of reservoir filler neck. If coolant is low, inspect gasket in cap for damage and replace if necessary. To have cap tested, contact your Authorized MerCruiser Dealer. Inspect coolant recovery system for leaks.

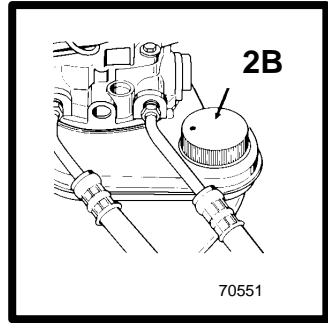
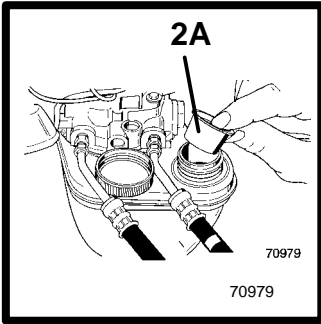
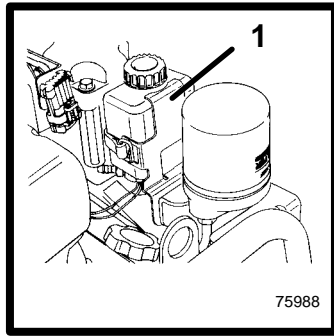

CHECKING DRIVE UNIT OIL

NOTE: *Oil level will fluctuate during operation. Oil level should be checked with cold engine before starting.*

1 Check gear lube monitor oil level; keep oil level at or near FULL line. Check for water at bottom of monitor and/or if oil appears to be discolored, contact your Authorized MerCruiser Dealer immediately; both conditions may indicate a water leak somewhere in the drive unit.

IMPORTANT: **If more than 2 fl. oz. (59ml) of Quicksilver High Performance Gear Lube is required to fill monitor, a seal may be leaking. Damage to drive unit may occur due to lack of lubrication. Contact your Authorized MerCruiser Dealer for service.**

CHECKING POWER TRIM PUMP FLUID

Place drive unit in full down/in position.

2 Remove fill cap from reservoir and observe oil level. Level must be up to, but not over bottom of filler neck. Add Quicksilver Power Trim and Steering Fluid or SAE 10W-30 motor oil, if required, to bring level to bottom of filler neck. Replace cap.

A Check that “Cap plug” has been **removed** from filler neck and **dis-carded**.

B Fill cap is vented; frequently check that vent is open and unrestricted.

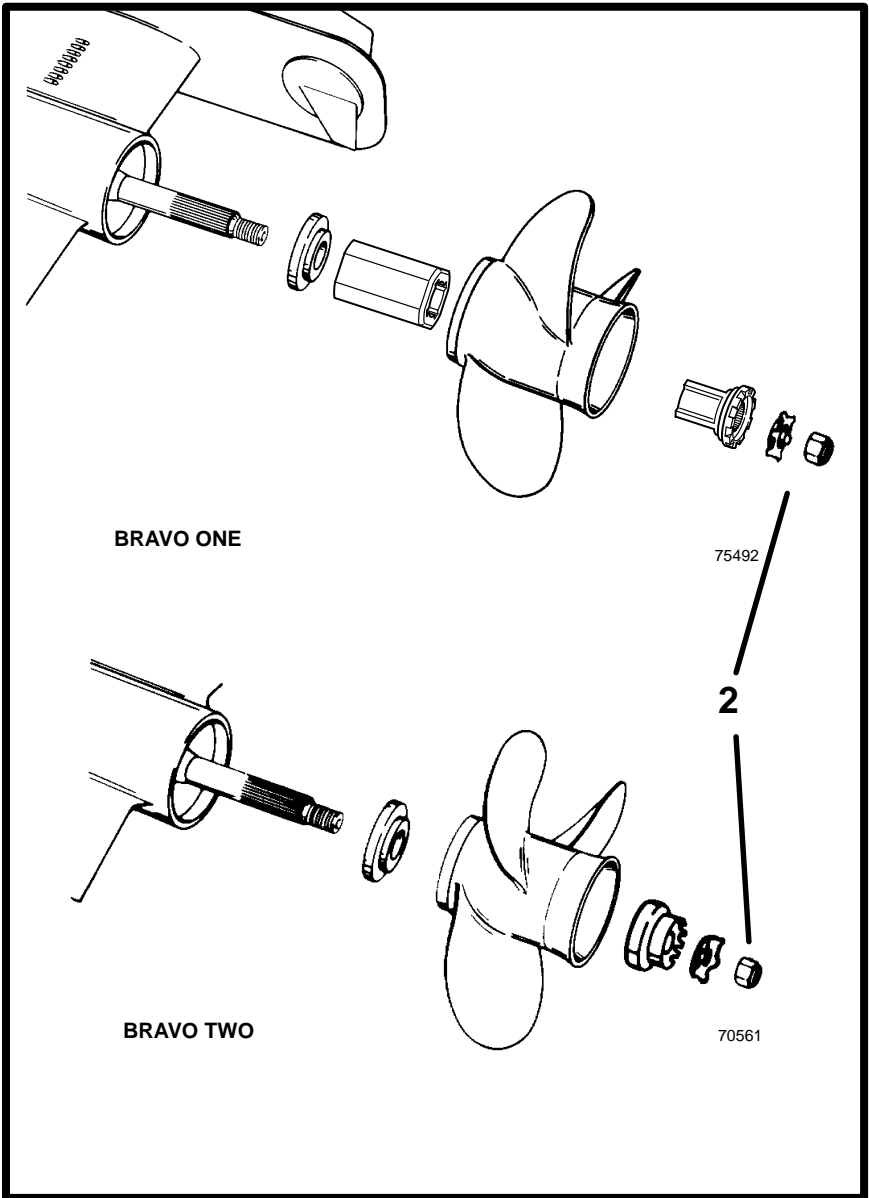

Propellers (Bravo One and Two)

WARNING

Avoid Injury: Remote Control must be in **NEUTRAL** and ignition key removed from switch before removing and/or installing propeller.

WARNING

Avoid Injury: Place a block of wood between anti-ventilation plate and propeller to protect hands from propeller blades and to prevent propeller from rotating when removing propeller nut.

CAUTION

Avoid Injury: Periodically check propeller nut for tightness during boating season. A minimum of 55 lbs. ft. (75 N-m) torque is required.

CA743

REMOVAL

- 1** Place wood block between propeller blade and anti-ventilation plate to prevent rotation. Straighten bent tabs on tab washer.
- 2** Turn propeller shaft nut counterclockwise to remove nut.
- 3** Slide tab washer, spline washer, propeller and thrust hub off propeller shaft.

CA79

REPAIR

Some damaged propellers can be repaired. See your dealer.

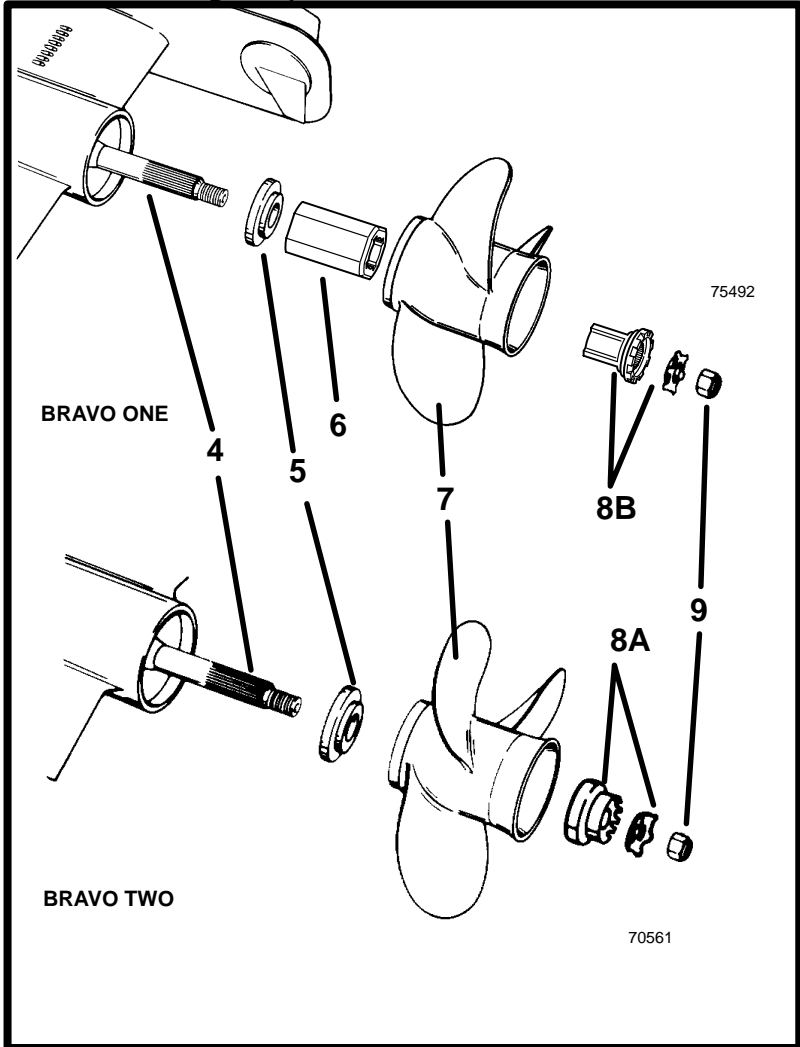

INSTALLATION (BRAVO ONE AND TWO)

IMPORTANT: If reusing tab washer, carefully inspect tabs for cracks or other damage. Replace tab washer if condition is questionable.

4 Apply a liberal coat of one of the following Quicksilver lubricants to propeller shaft: Anti-Corrosion Grease, Special Lubricant 101, or 2-4-C Marine Lubricant with Teflon.

5 Slide thrust hub into propeller hub, with stepped side toward propeller hub.

6 Bravo One: Install Flo-Torque II Drive Hub into propeller.

***NOTE:** The drive sleeve is tapered and will slide fully into the propeller as the nut is tightened and properly torqued.*

7 Align splines and place propeller on propeller shaft.

8 Install final attaching hardware.

A Bravo One: Install drive sleeve adapter and locking tab washer.

B Bravo Two: Install spline washer and tab washer.

9 Install propeller nut. Tighten nut securely. A minimum of 55 lbs. ft. (75 N·m) torque is required. Bend three tabs on tab washer down into grooves in spline washer. After first use, bend the three tabs straight, retighten propeller nut to minimum 55 lbs. ft. torque (75 N·m). Bend tabs back down into spline washer. Check propeller at least every 20 hours of operation. Do not operate with loose propeller.

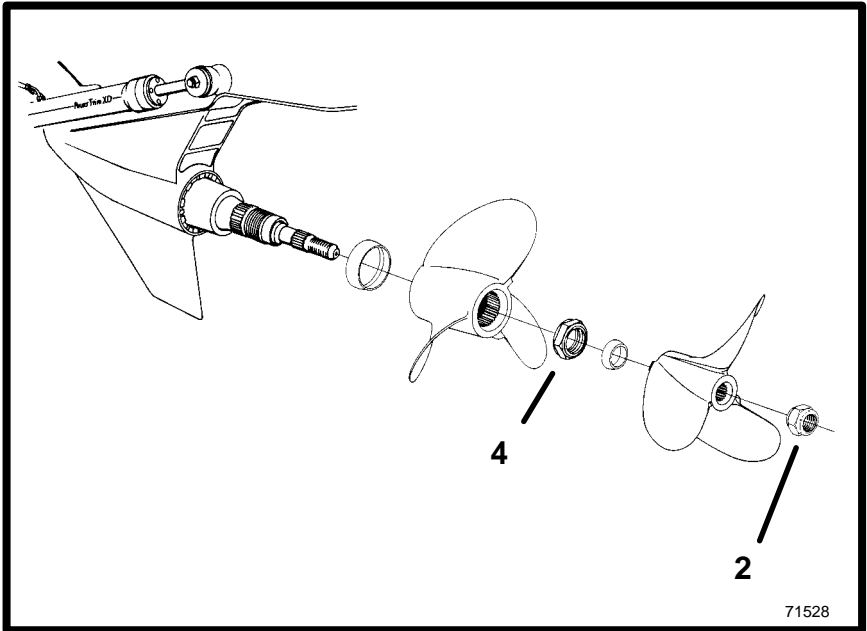

71528

Propellers (Bravo Three)

WARNING

Avoid Injury: Remote Control must be in **NEUTRAL** and ignition key removed from switch before removing and/or installing propeller.

WARNING

Avoid Injury: Place a block of wood between anti-ventilation plate and propeller to protect hands from propeller blades and to prevent propeller from rotating when removing propeller nut.

CAUTION

Avoid Injury: Periodically check propeller nut for tightness during boating season. A minimum of 55 lbs. ft. (75 N-m) torque is required.

REMOVAL (BRAVO THREE DRIVE)

- 1 Place wood block between propeller blades and anti-ventilation plate to prevent rotation.
- 2 Turn aft propeller shaft nut counterclockwise to remove nut.
- 3 Slide propeller and thrust hub off propeller shaft.
- 4 Turn front propeller shaft nut counterclockwise to remove nut.
- 5 Slide propeller and thrust hub off propeller shaft.

REPAIR

Some damaged propellers can be repaired. See your dealer.

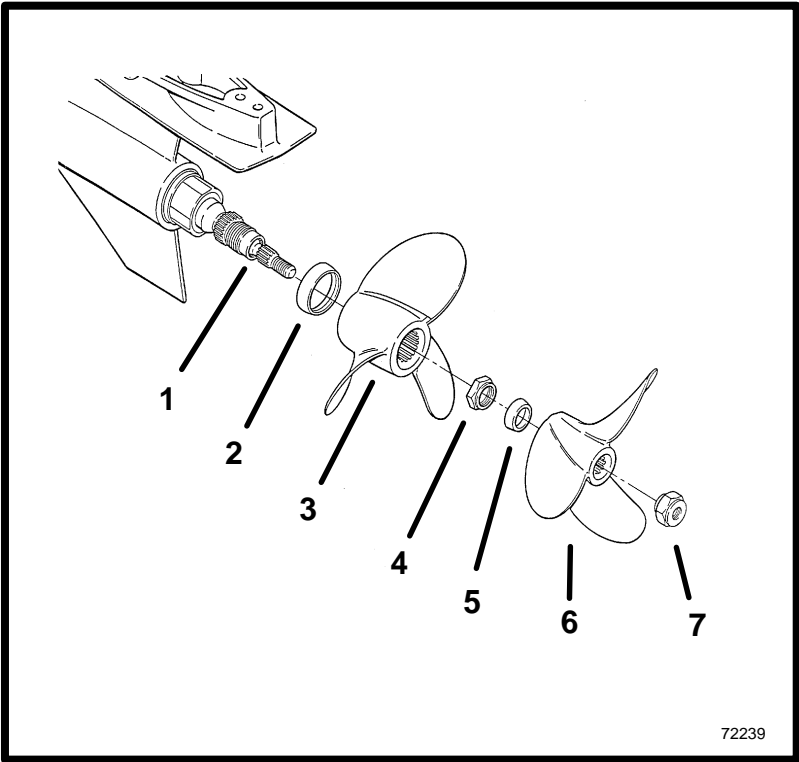

INSTALLATION (BRAVO THREE)

- 1** Apply a liberal coat of one of the following Quicksilver lubricants to both propeller shafts: Special Lubricant 101, 2-4-C Marine Lubricant with Teflon, or Anti-Corrosion Grease.
- 2** Slide forward thrust hub onto propeller shaft, with tapered side toward propeller hub (toward end of shaft).
- 3** Align splines and place propeller on propeller shaft.
- 4** Install propeller nut. Tighten nut securely. A minimum of 100 lbs. ft. (136 N·m) torque is required. Check propeller at least after 20 hours of operation. Do not operate with loose propeller.
- 5** Slide aft thrust hub onto propeller shaft, with tapered side toward propeller hub (toward end of shaft).
- 6** Align splines and place propeller on propeller shaft.
- 7** Install propeller nut. Tighten nut securely. A minimum of 60 lbs. ft. (81 N·m) torque is required. Check propeller at least after 20 hours of operation. Do not operate with loose propeller.

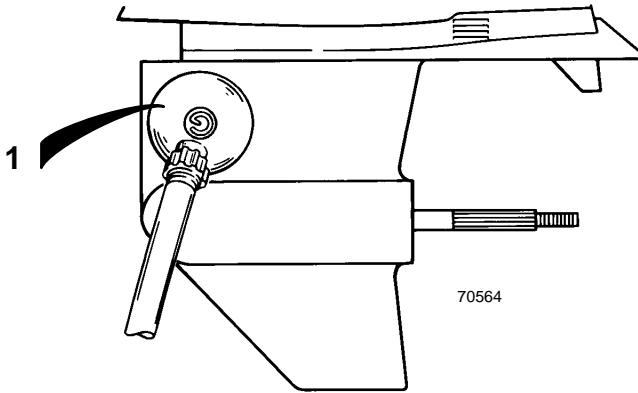
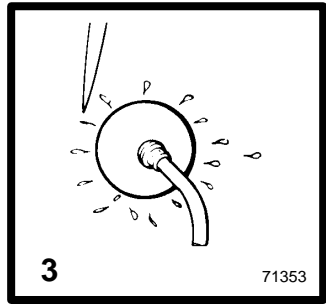
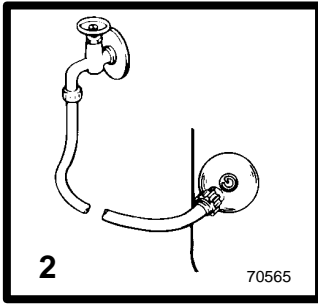

Flushing Cooling System

WARNING

When flushing, be certain the area around propeller is clear, and no one is standing nearby. To avoid possible injury, remove propeller.

CAUTION

Do not run engine above 1500 RPM when flushing. Suction created by seawater pickup pump may collapse flushing hose, causing engine and/or drive unit to overheat.

CAUTION

Watch temperature gauge on dash to ensure that engine does not overheat.

To prevent silt and/or salt buildup in cooling system, flush with freshwater at specified intervals.

CB672

If flushing cooling system with boat in water, raise drive unit to TRAILER position, install flushing attachment and lower drive unit to full DOWN/IN position.

- 1** Install Quicksilver flushing attachment (or equivalent) over water intake openings in gear housing.
- 2** Connect hose between flushing attachment and water tap.
- 3** With drive unit in normal operating position, partially open water tap (about 1/2 maximum). Place remote control in NEUTRAL, idle speed position and start engine. Operate engine at idle speed, in NEUTRAL, for about 10 minutes or until discharge water is clear. Stop engine, shut off water and remove flushing attachment.

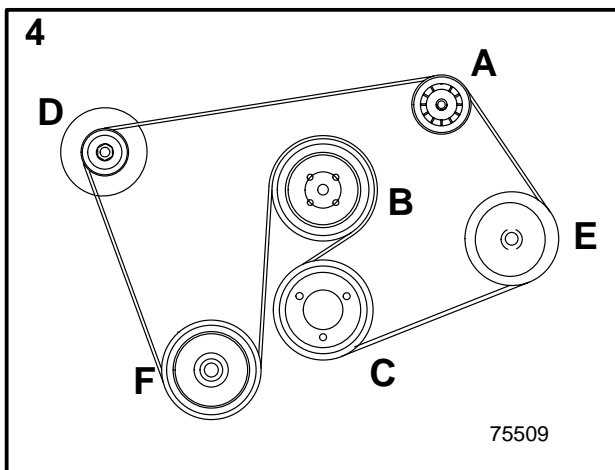
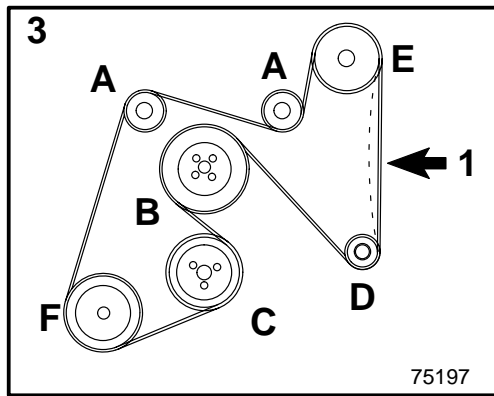
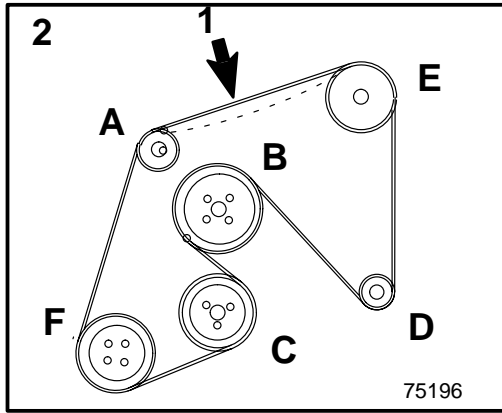

Serpentine Drive Belt

WARNING

Avoid possible serious injury. Make sure engine is shut off and ignition key is removed before inspecting belt.

Belt must be periodically inspected for condition and tension.

NOTE: *Belt deflection is to be measured on the belt at the location that has the longest distance between two pulleys. Normally this location is between the power steering pump and belt adjustment idler pulley on models without closed cooling. This location is between the power steering pump and alternator pulleys on models with closed cooling.*

1 Check the tension of the serpentine drive belt. If there is more than 1/4 in. (6 mm) deflection on the drive belt, see your Authorized MerCruiser Dealer to have the tension of the drive belt adjusted.

If any drive belts need replacement or tension needs adjustment, see your Authorized MerCruiser Dealer.

2 4.3L and 5.7L models without closed cooling

3 4.3L and 5.7L models with closed cooling

4 7.4L and 8.2L models

A Idler Pulley

B Circulating Pump Pulley

C Crankshaft Pulley

D Alternator Pulley

E Power Steering Pulley

F Seawater Pump Pulley

71176

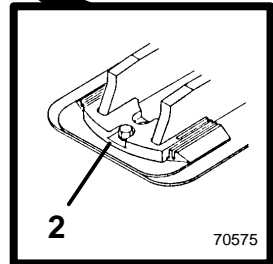
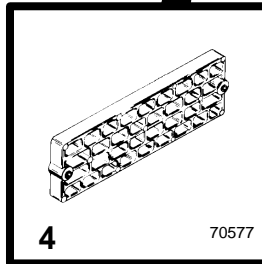
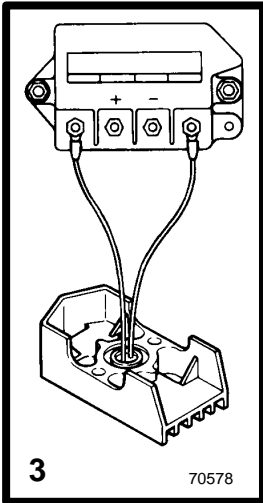
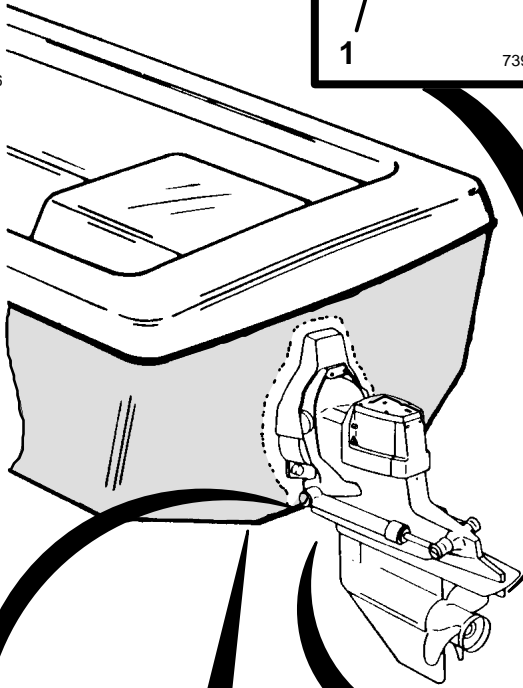
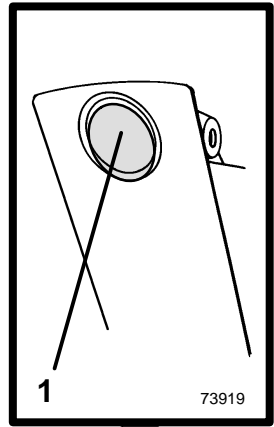

Corrosion And Corrosion Protection

Whenever two or more dissimilar metals (like those found on the sterndrive) are submerged in a conductive solution, such as saltwater, polluted water, or water with a high mineral content, a chemical reaction takes place causing electrical current to flow between metals. The electrical current flow causes the metal that is most chemically active, or anodic, to erode. This is known as galvanic corrosion and, if not controlled, it will in time cause the need for replacement of power package components exposed to water.

IMPORTANT: Replace sacrificial anodes if eroded 50% or more.

- 1 Universal Anodic Plate** - serves as a sacrificial anode.
- 2 Anodic Plate** - serves as a sacrificial anode.
- 3 MerCathode System** - should be tested to ensure adequate output.

Test should be made where boat is moored, using Quicksilver Reference Electrode and Test Meter. Contact your Authorized MerCruiser Dealer to arrange for this test.

- 4 Anode Kit (if so equipped)** - Mounted to boat transom. Acts as a sacrificial anode.

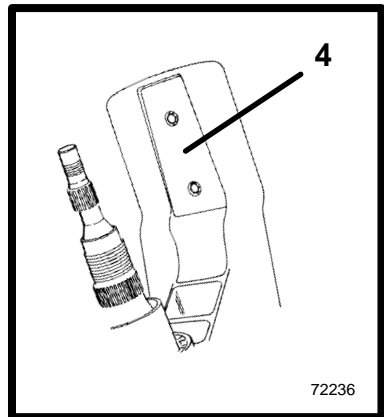
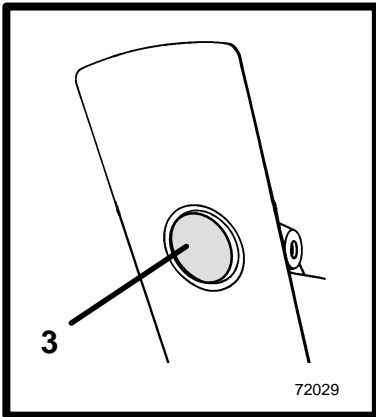
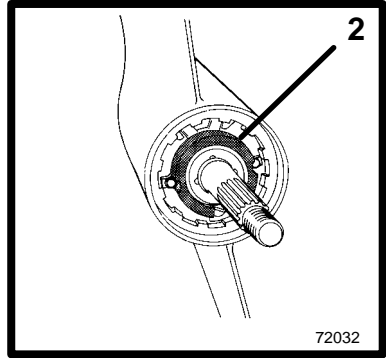
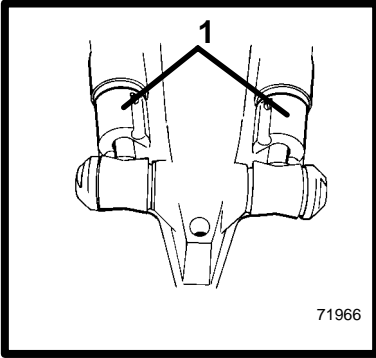

CA440

1 Trim Cylinder Anodes - are mounted on each trim cylinder.

CB764

2 Bearing Carrier Anode (Bravo One) - is located in front of the propeller, between the front side of the propeller and the gear housing. Refer to "Propeller" section in this manual for propeller removal and installation.

3 Gear Housing Anode (Bravo Two and Three) - is located in the splash plate, just above the propellers.

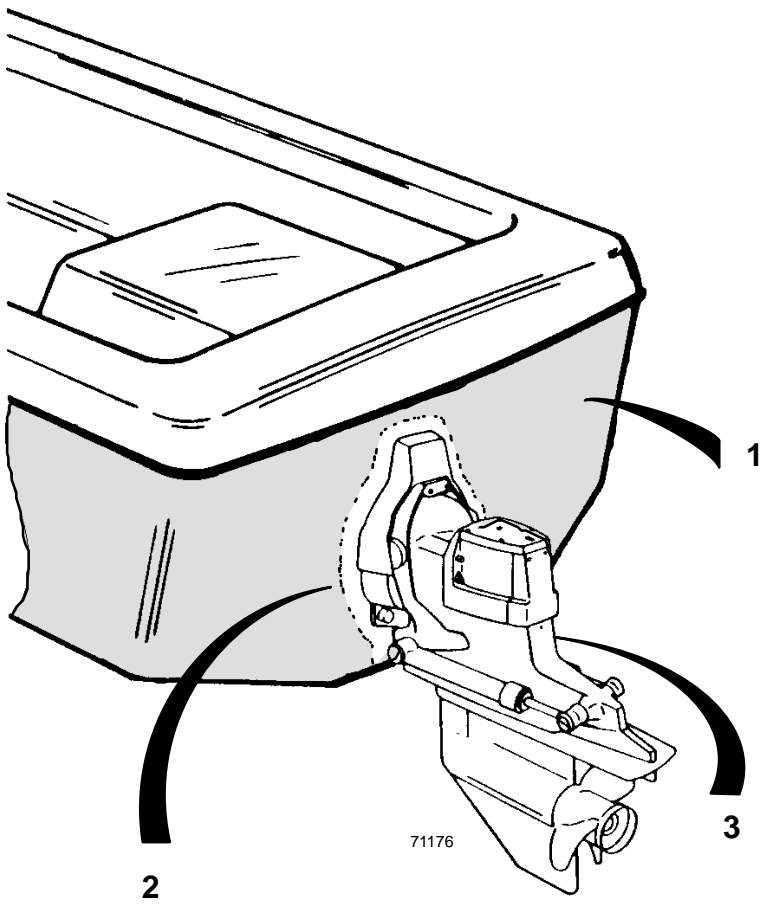

In addition to the corrosion protection devices, the following steps should be taken to inhibit corrosion:

IMPORTANT: Corrosion damage that results from the improper application of anti-fouling paint will not be covered by the limited warranty.

1 Painting Boat Hull or Boat Transom: Anti-fouling paint may be applied to boat hull and boat transom but you must observe the following precautions:

IMPORTANT: DO NOT paint anodes or MerCathode System reference electrode and anode, as this will render them ineffective as galvanic corrosion inhibitors.

IMPORTANT: If anti-fouling protection is required for boat hull or boat transom, copper or tin base paints, if not prohibited by law, can be used. If using copper or tin based anti-fouling paints, observe the following:

2 Avoid any electrical interconnection between the MerCruiser Product, Anodic Blocks, or MerCathode System and the paint by allowing a minimum of 1-1/2 in. (40mm) UNPAINTED area on transom of the boat around these items.

3 Painting Drive Unit or Transom Assembly: Drive unit and transom assembly should be painted with a good quality marine paint or an anti-fouling paint that DOES NOT contain copper, tin, or any other material that could conduct electrical current. Do not paint drain holes, anodes, MerCathode system, and items specified by boat manufacturer.

4 Spray power package components on inside of boat every 2-3 weeks with Quicksilver Corrosion Guard to protect finish from dulling and corrosion. External power package components may also be sprayed.

5 All lubrication points, especially steering system, shift and throttle linkages, should be kept well lubricated.

6 Flush cooling system periodically, preferably after each use.

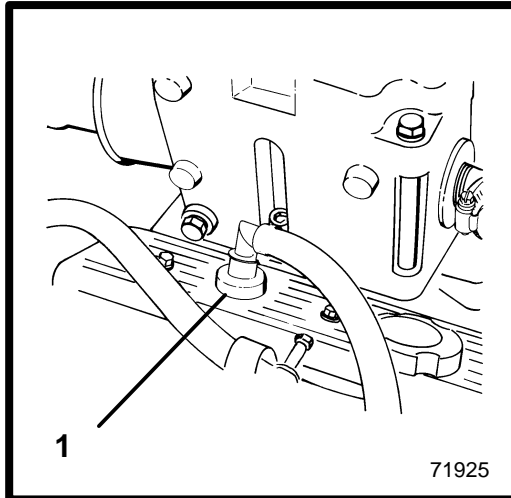
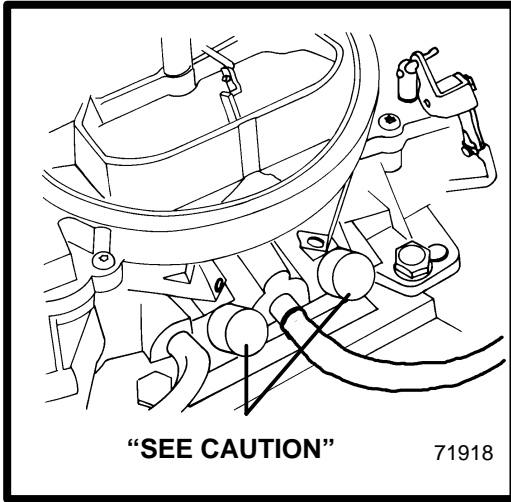

Emissions (Europe Only)

CA399

The following information applies only to engines with a special emissions kit installed. If the kit has been installed, your engine complies with “Stage 1” Bodensee and Swiss Regulations.

CA398

Sealed Carburetor Mixture Screws

The carburetor on this engine has seals on the carburetor mixture screws. These seals prevent adjustment of the fuel mixture settings.

CAUTION

Do not remove mixture screw seals and/or attempt to adjust fuel mixture setting. Tampering with the mixture setting on this engine could affect the exhaust emissions level, thus voiding the emissions certification. These seals should only be removed by an authorized dealer or emissions testing agency.

CA99

Changing Positive Crankcase Ventilation Valve (PCV)

This engine is equipped with a positive crankcase ventilation valve (PCV). This valve should be changed every 100 hours of operation or at least once a year, whichever occurs first.

1 Remove PCV valve from port valve cover. Disconnect it from the hose and discard valve. Install new PCV valve in valve cover and re-connect hose. Ensure valve is tightly seated in valve cover.

Use only MerCruiser replacement parts to ensure compliance with emission regulations.

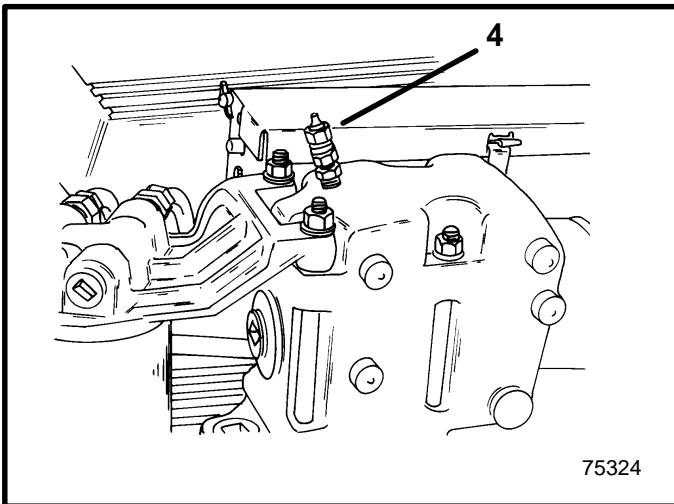
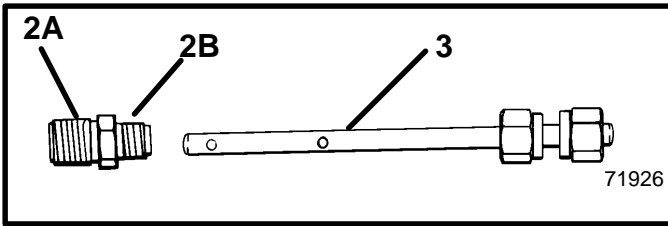
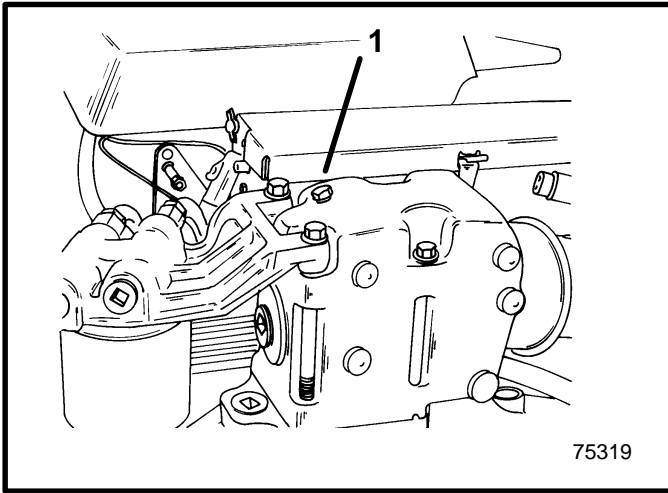

Emissions Testing

Your engine is equipped with special design features and special tuning to minimize the emission output from the engine. You should follow:

- Recommended maintenance schedules particularly as to the ignition system.
- Proper engine tuning procedures to ensure these features remain in good operating order.
- Proper steps to maintain the engine within specifications.

Installing Test Probes

IMPORTANT: The testing dealer or agency will be equipped with the appropriate test equipment and adapters for this engine. The test probes should be installed as follows:

- 1** Remove plugs from both exhaust elbows.
- 2** Install exhaust elbow adapter fittings as follows.
 - A** Apply Loctite Pipe Sealant with Teflon to threads that go into elbow.
 - B** Install fittings into elbows. Tighten fittings securely.
- 3** Insert exhaust probes into fittings and tighten securely.

The testing agency will connect their adapters and test equipment to the probes to conduct the test. Once the test is complete, they should remove the test probes and fittings, apply Quicksilver Perfect Seal to the threads of both plugs and reinstall them into elbows.

Miscellaneous Maintenance

Battery

All lead acid batteries discharge when not in use. Recharge every 30 to 45 days, or when specific gravity drops below battery manufacturer's specifications.

Refer to specific instructions and warnings accompanying your battery. If this information is not available, observe the following precautions when handling a battery.

WARNING

Avoid serious injury from gasoline fire or explosion. Do not use jumper cables and a booster battery to start engine. Do not recharge a weak battery in the boat. Remove battery and recharge in a ventilated area away from fuel vapors, sparks or flames.

WARNING

Batteries contain acid which can cause severe burns-Avoid contact with skin, eyes and clothing. Batteries also produce hydrogen and oxygen gases when being charged. This explosive gas escapes fill/vent cell caps and may form an explosive atmosphere around the battery for several hours after it has been charged. Sparks or flames can ignite the gas and cause an explosion which may shatter the battery and could cause blindness or other serious injury.

Safety glasses and rubber gloves are recommended when handling batteries or filling with electrolyte. Hydrogen gases that escape from the battery during charging are explosive. When charging batteries, be sure battery compartment or area where batteries are located, is well-vented. Battery electrolyte is a corrosive acid and should be handled with care. If electrolyte is spilled or splashed on any part of the body, immediately flush the exposed area with liberal amounts of water and obtain medical aid as soon as possible.

Bottom Of Boat

To maintain maximum speed, the following conditions of the boat bottom should be observed:

- Clean, free of barnacles and marine growth.
- Free of distortion, nearly flat where it contacts water.
- Straight and smooth, fore and aft.

ANTI-FOULING PAINTS

See Anti-Fouling Paint recommendations and related information on previous pages.

IMPORTANT: Refer to CORROSION AND CORROSION PROTECTION for additional information.

Inspection And Maintenance

Inspect power package often, and at regular intervals, to help maintain its top operating performance, and correct potential problems before they occur. The entire power package should be checked carefully, including all accessible engine parts.

Check for loose, damaged or missing parts, hoses and clamps; tighten or replace as required.

Check plug leads and electrical leads for damage.

Remove and inspect propeller. If badly nicked, bent or cracked, see your dealer.

Repair nicks and corrosion damage on power package exterior finish. Use Quicksilver spray paints - see your Authorized MerCruiser Dealer.

Cold Weather Or Extended Storage

Power Package Lay Up

IMPORTANT: MerCruiser strongly recommends that this service should be performed by an Authorized MerCruiser Dealer. Damage caused by freezing **IS NOT** covered by the MerCruiser Limited Warranty.

Battery Winter Storage

Follow battery manufacturer's instructions for storage.

Do-It-Yourself Maintenance

If you desire to perform your own maintenance, contact an Authorized MerCruiser Dealer to obtain a "Maintenance Procedures Manual." Refer to the Do-It-Yourself Maintenance Suggestions at the front of the manual for additional information.

Power Package Recommissioning

WARNING

To prevent possible injury or damage to equipment, do not install battery until all maintenance has been performed on engine.

- 1 Check that all cooling system hoses are connected properly and hose clamps are tight.

CAUTION

When installing battery, be sure to connect **NEGATIVE (-) battery cable to NEGATIVE (-) battery terminal and POSITIVE (+) battery cable to POSITIVE (+) battery terminal. If battery cables are reversed, electrical system damage will result.**

- 2 Install fully-charged battery. Clean battery cable clamps and terminals and reconnect cables (see CAUTION listed above). Tighten each cable clamp securely when connecting.
- 3 Coat terminal connections with a battery terminal anti-corrosion agent.
- 4 Perform all checks in OPERATION CHART in the BEFORE STARTING column.

CAUTION

Refer to **FLUSHING COOLING SYSTEM** before starting engine.

- 5 Start engine and closely observe instrumentation to make sure that all systems are functioning correctly.
- 6 Carefully inspect engine for fuel, oil, fluid, water and exhaust leaks.
- 7 Check steering system, shift and throttle control for proper operation.

Troubleshooting

Starter Motor Will Not Crank Engine, Or Cranks Slow

Possible Cause	Remedy
Battery switch turned off.	Turn switch on.
Remote control not in neutral position.	Position control lever in neutral.
Open circuit breaker or blown fuse.	Check and reset circuit breaker or replace fuse.
Loose or dirty electrical connections or damaged wiring.	Check all electrical connections and wires (especially battery cables). Clean and tighten faulty connection.
Bad battery.	Test and replace if bad.

Engine Will Not Start, Or Is Hard To Start

Possible Cause	Remedy
Improper starting procedure.	Read starting procedure.
Empty fuel tank or fuel shutoff valve closed.	Fill tank or open valve.
Choke not operating properly.	Carburetor Models: Check choke linkages for freedom of movement.
Engine Flooded.	Do not attempt to start engine for at least 5 minutes. Refer to Starting Procedures.
Faulty ignition system component.	Service ignition system.
Clogged fuel filters.	Replace filters.
Stale or contaminated fuel.	If contaminated, drain tank. Fill with fresh fuel.
Fuel line or tank vent line kinked or clogged.	Replace kinked lines or blow out lines with compressed air to remove obstruction.
EFI System Fault.	Have EFI System checked by an Authorized MerCruiser Dealer.

Engine Runs Rough, Misses And/Or Backfires

Possible Cause	Remedy
Idle speed too low.	EFI Models: Have EFI system checked by an Authorized MerCruiser Dealer.
Choke not operating properly.	Carburetor Models: Check choke linkages for binding or an obstruction.
Faulty ignition system component.	Service ignition system.
Clogged fuel filters.	Replace filters.
Stale or contaminated fuel.	If contaminated, drain tank. Fill with fresh fuel.
Kinked or clogged fuel line or fuel tank vent line.	Replace kinked lines or blow out lines with compressed air to remove obstruction.
Flame Arrestor plugged with foreign material.	Clean Flame Arrestor.
EFI System fault (If So Equipped).	Have EFI System checked.

Poor Performance

Possible Cause	Remedy
Throttle not fully open.	Inspect throttle cable and linkages for proper operation.
Damaged or improper propeller.	Replace propeller.
Excessive bilge water.	Drain and check for cause of entry.
Boat overloaded or load improperly distributed.	Reduce load or redistribute load more evenly.
Boat bottom fouled or damaged.	Clean or repair as necessary.
Flame Arrestor dirty.	Clean Flame Arrestor.
EFI System fault.	Have EFI System checked.

Excessive Engine Temperature

Possible Cause	Remedy
Seacock closed.	Open.
Drive belt loose or in poor condition.	Replace or adjust belt.
Seawater pickups obstructed.	Remove obstruction.
Faulty thermostat.	Replace.
Coolant level low in closed cooling section (If Equipped).	Check for cause of low coolant level and repair. Fill system with proper coolant solution.
Heat Exchanger Cores plugged with foreign material (If Equipped).	Clean Heat Exchanger.
Loss of pressure in closed cooling section (If Equipped).	Check for leaks. Clean, inspect and test pressure cap.
Faulty seawater pickup pump.	Repair.
Seawater discharge restricted or plugged.	Clean exhaust elbows.

CA448

Insufficient Engine Temperature

Possible Cause	Remedy
Faulty Thermostat.	Replace.

CA449

Low Engine Oil Pressure

Possible Cause	Remedy
Insufficient oil in crankcase.	Check and add oil.
Excessive oil in crankcase (causing it to become aerated).	Check and remove required amount of oil. Check for cause of excessive oil (improper filling, bad fuel pump, etc.).
Diluted or improper viscosity oil.	Change oil and oil filter, using correct grade and viscosity oil. Determine cause for dilution (excessive idling, faulty fuel pump, etc.).

CA450

Battery Will Not Come Up On Charge

Possible Cause	Remedy
Excessive current draw from battery.	Turn off non-essential accessories.
Loose or dirty electrical connections or damaged wiring.	Check all associated electrical connections and wires (especially battery cables). Clean and tighten faulty connections. Repair or replace damaged wiring.
Alternator drive belt loose or in poor condition.	Replace and/or adjust.
Unacceptable battery condition.	Test battery.

CA451

Remote Control Operates Hard, Binds, Has Excessive Free-Play Or Makes Unusual Sounds

Possible Cause	Remedy
Insufficient lubrication on shift and throttle linkage fasteners.	Lubricate.
Loose or missing shift and throttle linkages.	Check all throttle linkages. If any are loose or missing, see Authorized MerCruiser Dealer immediately.
Obstruction in shift or throttle linkages.	Remove obstruction.
Shift or throttle cable kinked.	Straighten cable or have dealer replace cable if damaged beyond repair.

CA452

Steering Wheel Turns Hard Or Jerky

Possible Cause	Remedy
Low power steering pump fluid level.	Refill system with fluid.
Drive belt loose or in poor condition.	Replace and/or adjust.
Insufficient lubrication on steering components.	Lubricate.
Loose or missing steering fasteners or parts.	Check all parts and fasteners if any are loose or missing, see Authorized MerCruiser Dealer immediately.
Contaminated power steering fluid.	Drain and replace.

Power Trim Does Not Operate (Motor Doesn't Run)

Possible Cause	Remedy
Blown fuse.	Replace fuse.
Loose or dirty electrical connections or damaged wiring.	Check all associated electrical connections and wires (especially battery cables). Clean and tighten faulty connection. Repair or replace wiring.

Power Trim Does Not Operate (Motor Runs But Drive Unit Does Not Move)

Possible Cause	Remedy
Trim pump oil level low.	Fill pump with oil.
Drive unit binding in gimbal ring.	Check for obstruction.

Warranty Information

Owner Warranty Registration

UNITED STATES AND CANADA ONLY

- It is important that your selling dealer fills out the Warranty Registration Card completely and mails it to the factory immediately upon sale of the new product.
- It identifies name and address of the original purchaser, product model and serial number(s), date of sale, type of use and selling dealer's code, name and address. The dealer also certifies that you are the original purchaser and user of the product.
- Upon receipt of the Warranty Registration Card at the factory, you will be issued a plastic Owner Warranty Registration Card which is your only valid registration identification. It must be presented to the servicing dealer should warranty service be required. Warranty claims will not be accepted without presentation of this card.
- A temporary Owner Warranty Registration Card will be presented to you when you purchase the product. It is valid only for 30 days from date of sale while your plastic Owner Warranty Registration Card is being processed. Should your product need service during this period, present the temporary registration card to the dealer. He will attach it to your warranty claim form.
- Because of your selling dealer's continuing personal interest in your satisfaction, the product should be returned to him for warranty service.
- If your plastic card is not received within 30 days from date of new product sale, please contact your selling dealer.
- The product warranty is not effective until the product is registered at the factory.
- **NOTICE:** Registration lists must be maintained by factory and dealer on marine products sold in the United States, should notification under the Federal Boat Safety Act be required.

International Owner Registration

OUTSIDE THE UNITED STATES AND CANADA

- It is important that your selling dealer fills out the Warranty Registration Card completely and mails it to the distributor or Marine Power Service Center responsible for administering the warranty registration/claim program for your area.
- The Warranty Registration Card identifies your name and address, product model and serial number(s), date of sale, type of use and the selling distributor's/dealer's code number, name and address. The distributor/dealer also certifies that you are the original purchaser and user of the product.
- A copy of the Warranty Registration Card, designated as the "Purchaser's Copy", MUST be given to you immediately after the card has been completely filled out by the selling distributor/dealer. This card represents your factory registration identification, and should be retained by you for future use when required. Should you ever require warranty service on this product, your dealer may ask you for the Warranty Registration Card to verify date of purchase and to use the information on the card to prepare the warranty claim form(s).
- In some countries, the Marine Power Service Center will issue you a permanent (plastic) Warranty Registration Card within 30 days after receiving the "Factory Copy" of the Warranty Registration Card from your distributor/dealer. If you receive a plastic Warranty Registration Card, you may discard the "Purchaser's Copy" that you received from the distributor/dealer when you purchased the product. Ask your distributor/dealer if this plastic card program applies to you.
- For further information concerning the Warranty Registration Card and its relationship to Warranty Claim processing, refer to the "International Warranty." Refer to "Table of Contents."

IMPORTANT: Registration lists must be maintained by the factory and dealer in some countries by law. It is our desire to have ALL products registered at the factory should it ever be necessary to contact you. Make sure your dealer/distributor fills out the warranty registration card immediately and sends the factory copy to the Marine Power International Service Center for your area.

Warranty Policies

MerCruiser Limited Warranty - Gasoline Engines UNITED STATES AND CANADA ONLY

- I. We warrant each new production (not those made for high performance purposes) MerCruiser Sterndrive Power Package, Inboard Engine and accessories attached thereto, (hereafter referred to as "Product") to be free from defects in material and workmanship, but only when the customer purchases or obtains predelivery service from a Dealer authorized by us to distribute MerCruiser Product in the country in which the sale or predelivery service occurred.
- II. This warranty shall become effective only upon our receipt of a completed Warranty Registration Card, which shall identify the Product so registered by serial number. This warranty shall remain in effect for a period of one (1) year from date of purchase.
- III. Since this warranty applies to defects in material and workmanship, it does not apply to normal worn parts, adjustments, tune-ups or to damage caused by: 1) Neglect, lack of maintenance, accident, abnormal operation or improper installation or service; 2) Use of an accessory or part not manufactured or sold by us; 3) Operation with fuels, oils or lubricants which are not suitable for use with the Product; 4) Participating in or preparing for racing or other competitive activity or operating with a racing type lower unit; 5) Alteration or removal of parts; or 6) Water entering engine cylinder/s through the exhaust system or carburetor/s.
- IV. Reasonable access must be provided to the product for warranty service. This warranty will not apply to: 1) Haul-out, launch, towing and storage charges; telephone or rental charges of any type, inconvenience, or loss of time or income; or other consequential damages; or 2) Removal and/or replacement of boat partitions or material because of boat design for necessary access to the Product.

- V. Claim shall be made under this warranty by delivering the Product for inspection to a MerCruiser dealer authorized to service the Purchaser's product. If purchaser cannot deliver Product to such authorized dealer, he may give notice in writing to the Company. We shall then arrange for the inspection and repair, provided such service is covered under this warranty. Purchaser shall pay for all related transportation charges and/or travel time. If the service is not covered by this warranty purchaser shall pay for all related labor and material and any other expenses associated with that service. Any Product or parts shipped by purchaser for inspection or repair must be shipped with transportation charges prepaid. The Warranty Registration Card is the only valid registration identification and must be presented at the time warranty service is required. Warranty claims will not be accepted without presentation of the Warranty Registration Card.
- VI. Our obligation under this Warranty shall be limited to repairing a defective part, or at our option, refunding the purchase price or replacing such part or parts with new or Mercury certified remanufactured parts as shall be necessary to remedy any malfunction resulting from defects in material or workmanship as covered by this Warranty. We reserve the right to improve the design of any Product without assuming any obligation to modify any Product previously manufactured.

VII. ALL INCIDENTAL AND/OR CONSEQUENTIAL DAMAGES ARE EXCLUDED FROM THIS WARRANTY. WARRANTIES OF MERCHANTABILITY AND FITNESS ARE EXCLUDED FROM THIS WARRANTY. IMPLIED WARRANTIES ARE LIMITED TO THE LIFE OF THIS WARRANTY. SOME STATES OR COUNTRIES DO NOT ALLOW LIMITATIONS ON HOW LONG AN IMPLIED WARRANTY LASTS OR THE EXCLUSION OR LIMITATION OF INCIDENTAL OR CONSEQUENTIAL DAMAGES, SO THE ABOVE LIMITATION OR EXCLUSIONS MAY NOT APPLY TO YOU.

- VIII. This warranty gives you specific legal rights, and you may also have other legal rights which vary from state to state.

MerCruiser International Warranty - Gasoline Engines

OUTSIDE THE UNITED STATES AND CANADA

- I. We warrant each new production (not those made for high performance purposes) MerCruiser Sterndrive Power Package, Inboard Engine and accessories attached thereto, (hereafter referred to as "Product") to be free from defects in material and workmanship, but only when the customer purchases or obtains predelivery service from a Dealer authorized by us to distribute MerCruiser Product in the country in which the sale or predelivery service occurred. This warranty shall remain in effect for a period of one (1) year from date of purchase.
- II. Since this warranty applies to defects in material and workmanship, it does not apply to normal worn parts, adjustments, tune-ups or to damage caused by: 1) Neglect, lack of maintenance, accident, abnormal operation or improper installation or service; 2) Use of an accessory or part not manufactured or sold by us; 3) Operation with fuels, oils or lubricants which are not suitable for use with the Product; 4) Participating in or preparing for racing or other competitive activity or operating with a racing type lower unit; or 5) Alteration or removal of parts or 6) Water entering engine cylinder/s through exhaust system or carburetor/s.
- III. Reasonable access must be provided to the Product for warranty service. This warranty will not apply to: 1) Haul-out, launch, towing and storage charges telephone or rental charges of any type, inconvenience, or loss of time or income or other consequential damages or 2) Removal and/or replacement of boat partitions or material because of boat design for necessary access to the Product.

- IV.** Claim shall be made under this warranty by delivering the Product for inspection to a MerCruiser dealer authorized to service the Product. If purchaser cannot deliver Product to such authorized dealer, he may give notice in writing to the Marine Power Service Center or distributor. The Marine Power Service Center or distributor shall then arrange for the inspection and repair, provided such service is covered under this warranty Purchaser shall pay for all related transportation charges and/or travel time. If the service is not covered by this warranty purchaser shall pay for all related labor and material, and any other expenses associated with that service. Any Product or parts shipped by purchaser for inspection or repair must be shipped with transportation charges prepaid.
- V.** Purchaser must provide “proof of purchase” and substantiate “date of purchase” by presenting the “Purchaser’s Copy” of the “Warranty Registration Card” or the plastic “Warranty Registration Card” to the dealer authorized to service the Product. If either of these items is not available purchaser must provide a copy of the original “Bill of Sale” (Sales Contract) for the Product to be serviced. Warranty claims will not be accepted until adequate “proof of purchase” is presented by purchaser and “date of purchase” has been substantiated.

VI. Our obligation under this Warranty shall be limited to repairing a defective part or AT OUR OPTION, refunding the purchase price or replacing such part or parts with new or Mercury certified remanufactured parts as shall be necessary to remedy any malfunction resulting from defects in material or workmanship as covered by this Warranty. We reserve the right to improve the design of any Product without assuming any obligation to modify any Product previously manufactured.

VII. ALL INCIDENTAL AND/OR CONSEQUENTIAL DAMAGES ARE EXCLUDED FROM THIS WARRANTY. WARRANTIES OF MERCHANTABILITY AND FITNESS ARE EXCLUDED FROM THIS WARRANTY. IMPLIED WARRANTIES ARE LIMITED TO THE LIFE OF THIS WARRANTY. SOME COUNTRIES DO NOT ALLOW LIMITATIONS ON HOW LONG AN IMPLIED WARRANTY LASTS OR THE EXCLUSION OR LIMITATION OF INCIDENTAL OR CONSEQUENTIAL DAMAGES, SO THE ABOVE LIMITATION OR EXCLUSIONS MAY NOT APPLY TO YOU.

VIII. This warranty gives you specific legal rights, and you may also have other legal rights which vary from country to country.

**MARINE POWER INTERNATIONAL
Division of Brunswick Corporation
Fond du Lac, Wisconsin 54935 U.S.A.**

3 Year Limited Warranty Against Corrosion Failure

(Applicable In The United States, Canada And Australia)

- I. We warrant parts and assemblies of each 1988 and newer production MerCruiser (Product) sold with a one year limited Product warranty or the Bravo and TRS Drive Units on performance Products that have a 90 day limited warranty rendered inoperative as a direct result of corrosion, provided the following simple precautionary steps which are specified in Owner's Manuals have been taken:
 1. Specified maintenance procedures (such as replacement of sacrificial anodes, specified lubrication and touch-up of nicks and scratches) have been implemented on a timely basis.
 2. Recommended corrosion prevention devices have been employed (details below).
- II. This warranty shall become effective upon receipt of a completed standard Product warranty registration card and shall remain effective for a period of three years from the date of purchase.
- III. This warranty does not cover: (1) electrical system corrosion; (2) corrosion resulting from damage, abuse or improper service; (3) corrosion to accessories, instruments, steering systems; (4) damage due to marine growth; (5) Product sold with less than a one year limited Product warranty except for Bravo and TRS Drive Units; nor (6) Product used in commercial application.

- IV.** ALL INCIDENTAL AND/OR CONSEQUENTIAL DAMAGES ARE EXCLUDED FROM THIS WARRANTY. WARRANTIES OF MERCHANTABILITY AND FITNESS ARE EXCLUDED FROM THIS WARRANTY. IMPLIED WARRANTIES ARE LIMITED TO THE LIFE OF THIS WARRANTY. SOME STATES (OR COUNTRIES) DO NOT ALLOW LIMITATIONS ON HOW LONG AN IMPLIED WARRANTY LASTS OR THE EXCLUSION OR LIMITATION OF INCIDENTAL OR CONSEQUENTIAL DAMAGES, SO THE ABOVE LIMITATION OR EXCLUSION MAY NOT APPLY TO YOU.
- V.** This warranty gives you specific legal rights, and you may also have other legal rights which vary from state to state (or country to country).
- VI.** Other details of this warranty are contained in paragraphs IV, V and VI of the (United States and Canada) Product Warranty, and paragraphs III, IV, V and VI of the (International) Product Warranty, contained in this manual, which paragraphs are incorporated herein by reference.

Mercury Marine products are built using the most advanced corrosion protection process available. This manufacturing system, complemented by dealer and customer participation in an anti-corrosion preventive maintenance program, provides protection against repair costs incurred by the effects of marine corrosion.

OWNER'S RESPONSIBILITY

Protection against certain types of corrosion damage must be provided by using such systems as the Quicksilver MerCathode System and/or Galvanic Isolator. These certain types of corrosion damage are: damage due to stray electrical currents (on-shore power connections, nearby boats, submerged metal), or improper application of copper base anti-fouling paint.

If anti-fouling protection is required, Tri-Butyl-Tin-Adipate (TBTA) base anti-fouling paints are recommended on MerCruiser boating applications. In areas where Tri-Butyl-Tin-Adipate base paints are prohibited by law, copper base paints can be used on the boat hull and transom. Do not apply paint to the MerCruiser drive unit or transom assembly. In addition, care must be taken to avoid an electrical interconnection between the MerCruiser Product and the paint. Corrosion damage that results from the improper application of copper base paint will not be covered by this limited warranty.

TRANSFER OF WARRANTY

This Limited Warranty is transferable to subsequent purchasers for the remainder of the unused portion of the 3-year limited corrosion warranty.

CA458

Warranty Coverage

The purpose of this section is to help eliminate some of the more common misunderstandings regarding warranty coverage. The table explains some of the types of services that are not covered by warranty.

Keep in mind that warranty covers repairs that are needed within the warranty period because of defects in material and workmanship. Installation errors, accidents, normal wear, and a variety of other causes that affect the product are not covered.

Warranty is limited to defects in material or workmanship, but only when the consumer sale is made in the country to which distribution is authorized by us.

Should you have any questions concerning warranty coverage, contact your authorized dealer. They will be pleased to answer any questions that you may have.

Warranty Does Not Apply To The Following:

- Minor adjustments and tune-ups, including checking, cleaning or adjusting spark plugs, ignition components, carburetor settings, filters, belts, controls, and checking lubrication made in connection with normal services.
- Damage caused by neglect, lack of maintenance, accident, abnormal operation or improper installation or service, or freezing temperatures.
- Haul-out, launch, towing charges; removal and/or replacement of boat partitions or material because of boat design for necessary access to the product; all related transportation charges and/or travel time, etc. Reasonable access must be provided to the product for warranty service. Customer must deliver product to an Authorized Dealer.
- Additional service work requested by customer other than that necessary to satisfy the warranty obligation.
- Labor performed by other than an Authorized Dealer may be covered only under following circumstances: When performed on emergency basis (providing there are no Authorized Dealers in area who can perform the work required or have no facilities to haul out, etc., and prior factory approval has been given to have the work performed at this facility).
- All incidental and/or consequential damages (storage charges, telephone or rental charges of any type, inconvenience or loss of time or income) are the owner's responsibility.
- Use of other than Quicksilver replacement parts when making warranty repairs.
- Oils, lubricants or fluids changed as a matter of normal maintenance is customer's responsibility unless loss or contamination of same is caused by product failure that would be eligible for warranty consideration.
- Participating in or preparing for racing or other competitive activity.

- Engine noise does not necessarily indicate a serious engine problem. If diagnosis indicates a serious internal engine condition which could result in a failure, condition responsible for noise should be corrected under the warranty.
- Lower unit and/or propeller damage caused by striking a submerged object is considered a marine hazard.
- Water entering the engine via the carburetor or exhaust system or submersion. Also water in the starter motor.
- Starter motors and/or armatures or field coil assembly, which are burned, or where lead is thrown out of commutator because of excess cranking.
- Valve or valve seat grinding required because of wear.
- Failure of any parts caused by lack of cooling water, which results from starting power package out of water, foreign material blocking inlets or power package being mounted too high.
- Use of fuels and lubricants which are not suitable for use with or on the product.
- Our limited warranty does not apply to any damage to our products caused by the installation or use of parts and accessories which are not manufactured or sold by us. Failures which are not related to the use of those parts or accessories, are covered under warranty, if they otherwise meet the terms of the limited warranty for that product.

Transferable Warranty

The product warranty is transferable to a subsequent purchaser, but only for the remainder of the unused portion of the limited warranty. This will not apply to products used for commercial applications.

Direct Sale By Owner

- The second owner can be registered as the new owner and retain the unused portion of the limited warranty by sending the former owner's plastic Owner Warranty Registration Card and a copy of the bill of sale to show proof of ownership. In the United States and Canada, mail to:

Mercury Marine

Attn: Warranty Registration Department

W6250 West Pioneer Road

P.O. Box 1939

Fond du Lac, WI 54936-1939

- A new Owner Warranty Registration Card will be issued with the new owner's name and address. Registration records will be changed on the factory computer registration file.
- There is no charge for this service.

Outside the United States and Canada, please contact the distributor in your country, or the Marine Power International Service Center closest to you, for the transferable warranty procedure that would apply to you.

Q-Guard Product Protection Plan

United States And Canada Only

(Certain performance products, triple engine installations, and commercial applications are excluded)

The Mercury Marine Q-Guard Product Protection Plan provides coverage against unexpected mechanical and electrical breakdowns that may occur beyond the standard limited warranty.

The optional Q-Guard Product Protection Plan is the only Factory Plan available for your engine.

Two, three or four - year term plans can be purchased up to 180 days after the original engine purchase date.

See your participating MerCruiser dealer for complete program details.

Owner Service Assistance

Local Repair Service

Always return your MerCruiser powered boat to your local Authorized Dealer, should the need for service arise. Only he has the factory trained mechanics, knowledge, special tools and equipment and the genuine Quicksilver parts and accessories* to properly service your engine should the need occur. He knows your engine best.

* Quicksilver parts and accessories are engineered and built by Mercury Marine, specifically for MerCruiser® sterndrives and inboards.

Service Away From Home

If you are away from your local dealer and the need arises for service, contact the nearest Authorized Dealer. Refer to the Yellow Pages of the telephone directory. If, for any reason, you cannot obtain service, contact the nearest Regional Service Center. Outside the United States and Canada, contact the nearest Marine Power International Service Center.

Parts And Accessories Inquiries

All inquiries concerning Quicksilver replacement parts and accessories should be directed to your local Authorized Dealer. The dealer has the necessary information to order parts and accessories for you should he not have them in stock. Only Authorized Dealers can purchase genuine Quicksilver parts and accessories from the factory. Mercury Marine does not sell to unauthorized dealers or retail customers. When inquiring on parts and accessories, the dealer requires the **motor model** and **serial number(s)** to order the correct parts.

Resolving A Problem

Satisfaction with your MerCruiser product is very important to your dealer and to us. If you ever have a problem, question or concern about your power package, contact your dealer or any Authorized MerCruiser Dealership. If additional assistance is required, take these steps.

1 *Talk with the dealership's sales manager or service manager. If this has already been done, then contact the owner of the dealership.*

2 *Should you have a question, concern or problem that cannot be resolved by your dealership, please contact Mercury Marine Service Office for assistance. Mercury Marine will work with you and your dealership to resolve all problems.*

The following information will be needed by the service office:

- Your name and address
- Daytime telephone number
- Model and serial number for your power package
- The name and address of your dealership
- Nature of problem

Mercury Marine Service Offices are listed on the next page.

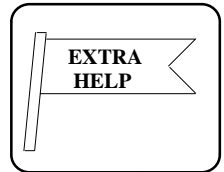
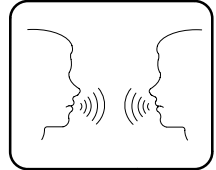

Mercury Marine Service Offices

For assistance, call, fax, or write. Please include your daytime telephone number with mail and fax correspondence.

 Telephone	 Fax	 Mail
United States		
(405) 743-6566	(405) 743-6570	MerCruiser 3003 N. Perkins Rd. Stillwater, OK 74075
Canada		
(905) 270-4481	(905) 270-4510	Mercury Marine Ltd. 1156 Dundas Hwy. E. Mississauga, Ontario Canada L4Y 2C2
Australia, Pacific		
(61) (3) 791-5822	(61) (3) 793-5880	Mercury Marine Australia 132-140 Frankston Road Dandenong, Victoria 3164 Australia
Europe, Middle East, Africa		
(32) (87) 32 • 32 • 11	(32) (87) 31 • 19 • 65	Marine Power - Europe, Inc. Parc Industriel de Petit-Rechain B-4800 Verviers Belgium
Mexico, Central America, South America, Caribbean		
(305) 385-9585	(305) 385-5507	Mercury Marine - Latin America & Caribbean 9010 S.W. 137th Ave. Suite 226 Miami, FL 33186 U.S.A.
Japan		
(81) 543/34-2500	(81) 543/34-2022	Mercury Marine - Japan No. 27-2 Muramatsu Chisaki-Shinden Shimizu City Shizuoka Prefecture Japan 424
Asia, Singapore		
(65) 270-7680	(65) 270-7898	Marine Power International, Ltd. Block 1002 Jalan Bukit Merah #07-08 Redhill Industrial Estate JTC Flatted Factories Singapore 0315

Customer Service Literature

English Language

English language publications are available from:

**Mercury Marine
Attn: Publications Department
W6250 West Pioneer Road
P.O. Box 1939
Fond du Lac, WI 54936-1939**

Outside the United States and Canada, contact the nearest Mercury Marine or Marine Power International Service Center for further information.

When ordering be sure to:

1. List your product, model, year and serial number(s).
2. Check the literature and quantities you want.
3. Enclose full remittance in check or money order (NO C.O.D.'s).

CA464

Other Languages

To obtain an Operation and Maintenance Manual or Maintenance Procedures Manual in another language, contact the nearest Mercury Marine or Marine Power International Service Center for information. A list of part numbers for other languages is provided with your power package.

caa464

Andre sprog

Kontakt det nærmeste Mercury Marine eller Marine Power International servicecenter for oplysninger om hvordan du kan anskaffe en Betjenings- og vedligeholdelsesmanual eller en manual med vedligeholdelsesprocedurer på et andet sprog. En liste med reservedelsnumre for andre sprog leveres sammen med din power-pakke.

cab464

Andere talen

Voor het verkrijgen van een Handleiding voor gebruik en onderhoud of een Onderhoudshandleiding in andere talen dient u contact op te nemen met het dichtstbijzijnde internationale servicecentrum van Mercury Marine of Marine Power voor informatie hierover. Een lijst met onderdeelnummers voor andere talen wordt bij uw motorinstallatie geleverd.

cac464

Muut kiellet

Saadaksesi Käyttö- ja huolto-ohjekirjoja muilla kielillä, ota yhteys lähimpään Mercury Marine tai Marine Power International huolto-keskukseen, josta saat lähempiä tietoja. Moottorisi mukana seuraa monikielinen varaosanumeroluettelo.

cad464

Autres langues

Pour obtenir un Manuel d'utilisation et d'entretien ou un Manuel d'entretien dans une autre langue, contactez le centre de service après-vente international Mercury Marine ou Marine Power le plus proche pour toute information. Une liste des numéros de pièces en d'autres langues accompagne votre bloc-moteur.

cae464

Andere Sprachen

Um eine Betriebs- und Wartungsanleitung oder ein Handbuch der Wartungsverfahren in einer anderen Sprache zu erhalten, wenden Sie sich an das nächste Mercury Marine oder Marine Power International Service Center. Eine Liste mit Teilenummern für Fremdsprachen ist im Lieferumfang Ihres Motors enthalten.

caf464

Altre lingue

Per ottenere il manuale di funzionamento e manutenzione o il manuale delle procedure di manutenzione in altra lingua, contattate il centro assistenza internazionale Mercury Marine o Marine Power più vicino. In dotazione con il gruppo motore, viene fornito l'elenco dei codici prodotto dei componenti venduti all'estero.

cag464

Andre språk

Ytterligere informasjon om bruks- og vedlikeholdshåndbok eller servicehåndbok på andre språk kan fås ved henvendelse til nærmeste internasjonale servicecenter for Mercury Marine eller Marine Power. En liste over delenumre for andre språk følger med aggregatet.

cah464

Outros Idiomas

Para obter um Manual de Operação e Manutenção ou um Manual de Procedimentos de Manutenção em outro idioma, contate o Centro de Serviço Internacional de “Marine Power” (Potência Marinha) ou a Mercury Marine mais próxima para obter informações. Uma lista de números de referência para outros idiomas é fornecida com o seu pacote de propulsão.

caj464

Otros idiomas

Para obtener un Manual de operación y mantenimiento o un Manual de procedimientos en otro idioma, póngase en contacto con el centro de servicio más cercano de Mercury Marine o Marine Power International para recibir información. Con su conjunto motriz se entrega una lista de los números de pieza para los otros idiomas.

cak464

Andra språk

För att få Instruktions- och underhållsböcker på andra språk, kontakta närmaste Mercury Marine eller Marine Power International servicecenter, som kan ge ytterligare information. En förteckning över artikelnummer på andra språk medföljer ditt kraftpaket.

Ordering Literature



Before ordering literature, please have the following information about your power package available:

Model _____ **Horsepower** _____
Serial Number _____ **Year** _____

United States and Canada

For information on additional literature that is available for your particular MerCruiser power package and how to order that literature contact your nearest dealer or contact:

Mercury Marine

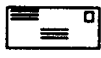
Telephone 	Fax 	Mail 
(920) 929-5110	(920) 929-4894	Mercury Marine Attn: Publications Department P.O. Box 1939 Fond du Lac, WI 54936-1939

Outside The United States and Canada

Contact your nearest dealer or Marine Power Service Center for information on additional literature that is available for your particular MerCruiser power package and how to order that literature.

Please return with payment to:

Mercury Marine
 Attn: Publications Department
 P.O. Box 1939
 Fond du Lac, WI 54936-1939

Ship To: (Please Print Or Type - This Is Your Shipping Label)

Name _____

Address _____

City _____ State _____ ZIP _____
