

Diesel Engines - Bravo Models

Identification Record

Please record the following information:

1.	Engine Model and Horsepower	Engine Serial Number
2.	Transom Assembly Serial Number (Stern Drive)	Gear Ratio Stern Drive Unit Serial Number
3.	Transmission Model (Inboard)	Gear Ratio Transmission Serial Number
4.	Propeller Number	Pitch Diameter
5.	Hull Identification Number (HIN)	Purchase Date
6.	Boat Manufacturer	Boat Model Length
7.	Exhaust Gas Emissions Certificate Number (Europe Only)	

Serial Numbers

The serial numbers are the manufacturer's keys to numerous engineering details which apply to your MerCruiser® power package. When contacting your Authorized MerCruiser Dealer about service, **always specify model and serial numbers.**

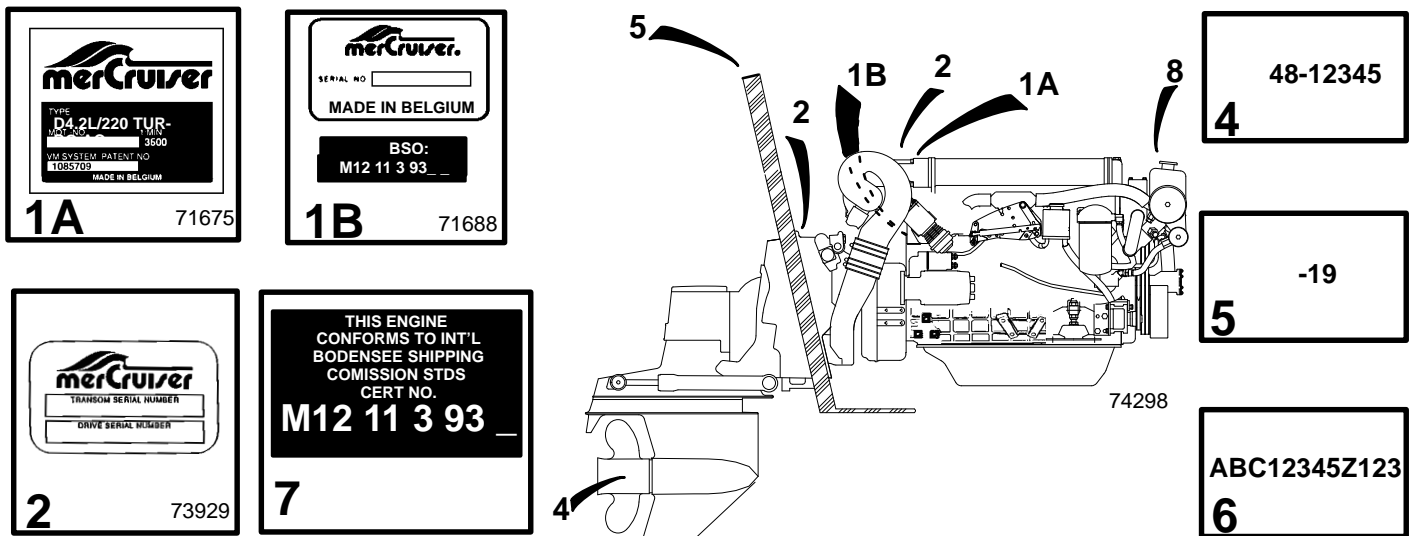

The description and specifications contained herein were in effect at the time this guide was approved for printing. Mercury Marine, whose policy is one of continuous improvement, reserves the right to discontinue models at any time, or to change specifications or designs, without notice and without incurring obligation.

Mercury Marine, Fond du Lac, Wisconsin, U.S.A.

Printed in U.S.A.

©1996, Mercury Marine

The following are registered trademarks of Brunswick Corporation: Auto-blend, Jet-Prop, Mariner, Merc, MerCathode, MerCruiser, Mercury, Mercury Marine, Quicksilver, Ride-Guide, and Thruster.

TABLE OF CONTENTS

	Page
WELCOME!	3
Read This Manual Thoroughly	4
Lanyard Stop Switch	5
Exhaust Emissions	7
Be Alert To Carbon Monoxide Poisoning	7
Poor Ventilation	7
Good Ventilation	7
Safe Boating Suggestions	8
Protecting People In The Water	9
While You Are Cruising	9
While Boat Is Stationary	9
High-Speed And High-Performance Boat Operation	9
Conditions Affecting Operation	10
Weight Distribution	10
Bottom Of Boat	10
Cavitation	10
Ventilation	10
Propeller Selection	11
How Elevation And Climate Affect Performance	12
Operation And Maintenance	13
Recommended Operation/Duty Cycle	13
Owner/Operator Responsibilities	14
Dealer Responsibilities	14
Freezing Temperature And Cold Weather Operation	15
Drive Unit Impact Protection	15
Launching and Boat Operation Care	16
Attention Required After Submersion	16
Trailing Boat	16
Stolen Power Package	16
Replacement Service Parts	17
Do-It-Yourself Maintenance Suggestions	17
Diagnosing EDI Problems (If So Equipped)	17
Engine Break-In	18
Initial Break-In Procedure	18
20-Hour Break-In Period	18
After Break-In Period	19
End of First Season Checkup	19
Specifications	20
Seacock	20
Seawater Strainer	20
Fuel Requirements	20
Diesel Fuel In Cold Weather	21
Crankcase Oil	21
Engine	22
Capacities	23
Required Coolant: Quicksilver Premixed Marine Engine Coolant	23
Quicksilver Instruments and Instrumentation	25
Operation	27
Electrical System Overload Protection	27
Mercathode System	27
Remote Controls	29
Power Trim	31
Starting, Shifting and Stopping - D3.6L/180 and D4.2L/220	36
Operation Chart - D3.6L/180 and D4.2L/220	39
Starting, Shifting and Stopping - D2.8L D-Tronic and D4.2L D-Tronic	40
Operation Chart - D2.8L D-Tronic and D4.2L D-Tronic	43
Maintenance	44
General Maintenance Information	44
Maintenance Aids	44
Maintenance Schedules	45
Checking Fluid Levels	49

	Page
Crankcase Oil	49
Drive Unit Oil	49
Power Steering Pump Fluid	49
Engine Coolant	51
Power Trim Pump Fluid	51
Seawater Pump Impeller	53
Flushing Fuel Tank	53
Propellers (Bravo One and Two)	53
Propellers (Bravo Three)	55
Cleaning Quicksilver Seawater Strainer	57
Flushing Seawater Cooling System	57
Fuel System	59
Fuel Tank	59
Hand Pump/Primer	59
Priming Fuel System	59
Filling Fuel Filter	59
Filling (Bleeding) Fuel System	59
Draining Water Separating Fuel Filter	59
Replacing Water Separating Fuel Filter	61
Corrosion And Corrosion Protection	61
Internal Components	61
External Components	63
Miscellaneous Maintenance	67
Cold Weather Or Extended Storage	68
Power Package Layup	68
Battery Winter Storage	68
Power Package Recommissioning	68
Troubleshooting	69
Starter Motor Will Not Crank Engine, Or Cranks It Very Slowly	69
Engine Will Not Start, Or Is Hard To Start	69
Engine Runs Rough, Misses And/OR Backfires	70
Poor Performance	70
Excessive Engine Temperature	71
Insufficient Engine Temperature	71
Low Engine Oil Pressure	72
Battery Will Not Come Up On Charge	72
Remote Control Operates Hard, Binds, Has Excessive Free-play Or Makes Unusual Sounds	72
Steering Wheel Turns Hard Or Jerky	73
Power Trim Does Not Operate (Electric Motor Does Not Run)	73
Power Trim Does Not Operate (Electric Motor Runs But Drive Unit Does Not Move)	73
Warranty Information	74
Owner Warranty Registration	74
International Owner Registration	75
Warranty Policy	76
Mercruiser Diesel Limited Warranty	76
Marine Power International Branch or Distributor Service Offices	78
Warranty Coverage	79
Transferable Warranty	80
Q-GUARD Product Protection Plan	80
Owner Service Assistance	81
Local Repair Service	81
Service Away From Home	81
Parts And Accessories Inquiries	81
Resolving A Problem	81
Mercury Marine Service Offices	82
Customer Service Literature	82
English Language	83
Other Languages	83
Literature Order Form	85

Welcome!

You have selected one of the finest marine power packages available. It incorporates numerous design features to assure operating ease and durability.

With proper care and maintenance, you will thoroughly enjoy using this product for many boating seasons. To ensure maximum performance and carefree use, we ask that you thoroughly read this manual.

The Operation and Maintenance Manual contains specific instructions for using and maintaining your product. We suggest that this manual remain with the product for ready reference whenever you are on the water.

Thank you for purchasing one of our MerCruiser products. We sincerely hope your boating will be pleasant!

CONSUMER AFFAIRS DEPARTMENT

IMPORTANT: This manual contains basic Operation and Maintenance information for your MerCruiser power package. If you desire to perform some of the maintenance items on your own, you should obtain a copy of the “Maintenance Procedures” Manual for your particular power package. Information for obtaining this manual is located at the back of this manual.

Read This Manual Thoroughly

IF YOU DON'T UNDERSTAND ANY PORTION, CONTACT YOUR DEALER FOR A DEMONSTRATION OF ACTUAL STARTING AND OPERATING PROCEDURES.

NOTICE

Throughout this publication, and on your power package **WARNINGS** and **CAUTIONS**, accompanied by the International HAZARD Symbol , may be used to alert the installer/user to special instructions concerning a particular service or operation that may be hazardous if performed incorrectly or carelessly. **Observe them carefully.**

These "Safety Alerts" alone cannot eliminate the hazards that they signal. Strict compliance with these special instructions while performing the service, plus "common sense" operation, are major accident prevention measures.

WARNING

WARNING - Hazards or unsafe practices which could result in severe personal injury or death.

CAUTION

CAUTION - Hazards or unsafe practices which could result in minor personal injury or product or property damage.

IMPORTANT: Indicates information or instructions that are necessary for proper operation and/or maintenance.

WARNING

The operator (driver) is responsible for the correct and safe operation of the boat, the equipment aboard and the safety of all occupants aboard. We strongly recommend that the operator read this Operation and Maintenance Manual and thoroughly understand the operational instructions for the power package and all related accessories before the boat is used.

We strongly recommend that other occupants be instructed on proper starting and operation procedures so they will be prepared should they be required to operate the power package and boat in an emergency.

WARNING

The use of accessories not manufactured or sold by Mercury Marine is not recommended for use with your MerCruiser unit. If your MerCruiser unit is equipped with an accessory not manufactured by Mercury Marine, be sure to read the Operation and Maintenance Manual for the accessory before operation. If you haven't been supplied with such a manual, contact your dealer or the manufacturer of the accessory to secure the applicable manual.

WARNING

Electrical system components on this engine are not external ignition protected. **DO NOT STORE OR UTILIZE GASOLINE ON BOATS EQUIPPED WITH THESE ENGINES, UNLESS PROVISIONS HAVE BEEN MADE TO EXCLUDE GASOLINE VAPORS FROM ENGINE COMPARTMENT (REF: 33 CFR).** Failure to comply could result in fire, explosion and/or severe personal injury.

Lanyard Stop Switch

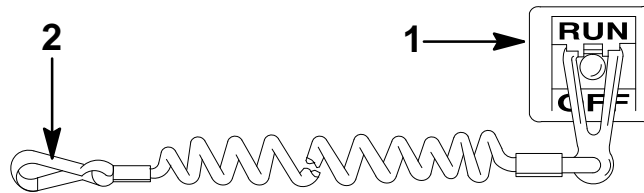

74608

1 Some boats come equipped with a lanyard stop switch. A lanyard stop switch can also be installed as an accessory. The purpose of this switch is to turn off the engine ignition whenever the operator (when attached to the lanyard) moves far enough away from the operator's position to activate the switch.

2 The lanyard is a cord usually between 4 and 5 feet (1220 and 1524 mm) in length when stretched out with an element on one end made to be inserted into the switch and a metal snap on the other end for attaching to the operator. It is coiled to make its at rest condition as short as possible so as to minimize the likelihood of lanyard entanglement with nearby objects. It is made as long as it is in its stretched condition to minimize the likelihood of accidental activation should the operator choose to move around in an area close to the normal operator's position. If for any reason it is desired to have a shorter functional lanyard, this may be accomplished by using up length in the way the lanyard and clip are attached to the operator (such as wrapping the lanyard around the operator's wrist or leg) or by tying a simple knot in the lanyard.

Read the Safety Warning on this page and the following page before electing to install, use, or not to use such a switch.

⚠ WARNING

The following advantages and disadvantages of a lanyard stop switch should be considered before electing to use, or not to use, such a switch.

ADVANTAGES: The purpose of a lanyard stop switch is to stop the engine ignition whenever the operator (when attached to the lanyard) moves far enough away from the operator's position to activate the switch. This would occur if the operator falls overboard or moves within the boat a sufficient distance from the operator's position. This type of accident is most likely in certain types of boats such as low-sided boats, and high-performance boats. It is also likely as a result of poor operating practices such as sitting on the back of the seat at planing speeds, standing at planing speeds, operating at high speeds in shallow or obstacle-infested waters, releasing your grip on a steering wheel that is pulling in one direction, drinking and driving, or daring, high-speed boat maneuvers.

DISADVANTAGES: Inadvertent activation of the switch is also a possibility. This could cause any, or all, of the following potentially hazardous situations:

1. Loss of balance and falling forward of unstable boat passengers, a particular concern in bow rider type boats.
2. Loss of power and directional control in heavy seas, strong current or high winds.
3. Loss of control when docking.

While activation of the lanyard stop switch will result in immediate power shut-down, a boat will continue to coast for some distance depending upon the velocity and degree of any turn at shut-down. However, the boat will not complete a full circle. While the boat is coasting, it can cause injury to anyone in the boat's path as seriously as the boat would when under power.

As we cannot possibly know of and advise the boating public of all conceivable boat/motor types and/or poor operating practices, the final decision of whether to use a lanyard stop switch rests with you, the owner/driver. However, use common sense when considering the above advantages and disadvantages. For general operation, it is recommended that the lanyard stop switch be used.

We strongly recommend that other occupants be instructed on proper starting and operating procedures should they be required to operate the engine and boat in an emergency.

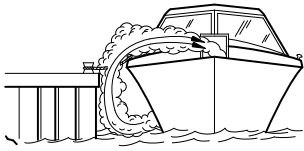

1A

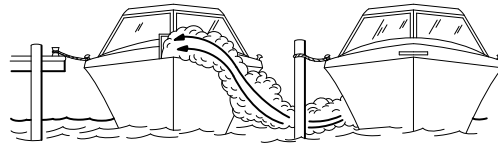

1B

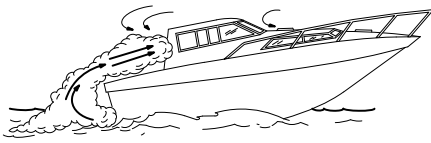

2A

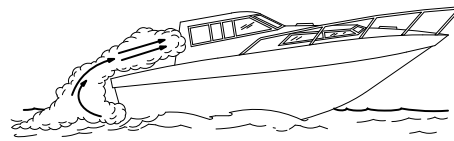

2B

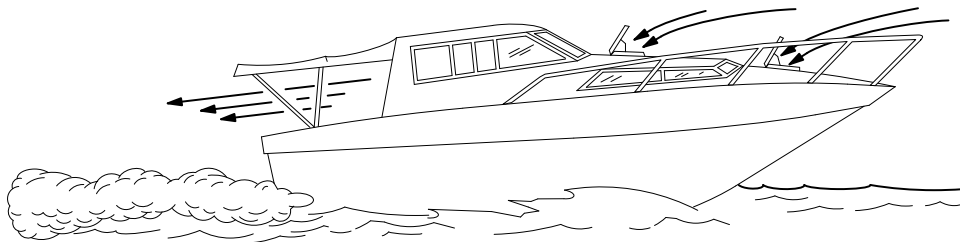

3

Exhaust Emissions

Be Alert To Carbon Monoxide Poisoning

Carbon monoxide is produced in the exhaust fumes of all internal combustion engines, including the outboards, sterndrives and inboard engines that propel boats, as well as the generators that power various boat accessories. Carbon monoxide is a deadly gas that is colorless, odorless, and tasteless.

Prolonged exposure to carbon monoxide in sufficient concentration can lead to unconsciousness, brain damage, or death. Early symptoms, which should not be confused with seasickness or intoxication, include headache, dizziness, drowsiness, and nausea.

Poor Ventilation

Under certain running and/or wind conditions, permanently enclosed or canvas enclosed cabins or cockpits with insufficient ventilation may draw in carbon monoxide. Install one or more carbon monoxide detectors in such areas.

Examples of Poor Ventilation:

- 1** While boat is stationary
 - A** Running the engine when the boat is moored in a confined space.
 - B** Mooring close to another boat that has its engine idling.
- 2** While boat is moving
 - A** Running the boat with the trim angle of the bow too high.
 - B** Running the boat with no forward hatches open (station wagon effect).

Good Ventilation

Ventilate passenger area, open side curtains, or forward hatches to remove fumes.

Example of Good Ventilation:

- 3** Desired air flow through the boat.

Safe Boating Suggestions

In order to safely enjoy the waterways, familiarize yourself with local and other governmental boating regulations and restrictions, and consider the following suggestions.

- **Know and obey all nautical rules and laws of the waterways.** Boat operators should complete a boating safety course. Courses are offered in the U.S.A. by (1) The U.S. Coast Guard Auxiliary, (2) The Power Squadron, (3) The Red Cross and (4) your state or provincial boating law enforcement agency. Inquiries may be made to the Boating Hotline, 1-800-368-5647 or the Boat U.S. Foundation information number 1-800-336-BOAT.

We strongly recommend that all powerboat operators attend one of these courses.

You should also review the NMMA Sources of Waterway Information booklet. It lists regional sources of safety, cruising and local navigation and is available at no charge by writing to:

Sources of Waterway Information
National Marine Manufacturers Association
410 N. Michigan Avenue
Chicago, IL 60611 U.S.A.

- **Perform safety checks and required maintenance.** Follow a regular schedule and ensure that all repairs are properly made.
- **Check safety equipment on board.** Here are suggestions of the types of safety equipment to carry when boating:
 - (1) Approved fire extinguisher(s); paddle or oar.
 - (2) Signal devices: flashlight, rockets or flares, flag and whistle or horn.
 - (3) Spare propeller, thrust hubs and an appropriate wrench.
 - (4) Tools for necessary minor repairs; first aid kit and book.
 - (5) Anchor and extra anchor line; water-proof storage containers.
 - (6) Manual bilge pump and extra drain plugs; compass and map or chart of area.
 - (7) Spare operating equipment; batteries, bulbs, fuses, etc.
 - (8) Transistor radio
 - (9) Drinking water
- **Know signs of weather change and avoid foul weather and rough-sea boating.**
- **Tell someone where you are going and when you expect to return.**
- **Passenger boarding.** Stop the engine whenever passengers are boarding, unloading or are near the back (stern) of the boat. Just shifting the drive unit into neutral is not sufficient.
- **Use personal flotation devices.** Federal Law requires that there be a U. S. Coast Guard approved, wear-able-type life jacket (personal flotation device), correctly sized and readily accessible for every person on board, plus a throwable cushion or ring. We strongly advise that everyone wear a life jacket at all times while in the boat.
- **Prepare other boat operators.** Instruct at least one person on board in the basics of starting and operating the engine and boat handling in case the driver becomes disabled or falls overboard.
- **Do not overload your boat.** Most boats are rated and certified for maximum load (weight) capacities (refer to your boat capacity plate). When in doubt, contact your dealer or the boats manufacturer. Know your boat's operating and loading limitations.
- **Make sure everyone in the boat is properly seated.** Don't allow anyone to sit or ride on any part of the boat that was not intended for such use. This includes backs of seats, gunwales, transom, bow, decks, raised fishing seats, any rotating fishing seat; anywhere that sudden unexpected acceleration, sudden stopping, unexpected loss of boat control or sudden boat movement could cause a person to be thrown overboard or into the boat.

- **Never be under the influence of alcohol or drugs while boating (it is the law).** They impair your judgment and greatly reduce your ability to react quickly.
- **Know your boating area and avoid hazardous locations.**
- **Be alert.** The operator of the boat is responsible by law to “maintain a proper lookout by sight (and hearing).” The operator must have an unobstructed view particularly to the front. No passengers, load, or fishing seats should block the operators view when operating the boat above idle or planing transition speed. Watch “the other guy,” the water and your wake.
- **Never drive your boat directly behind a water skier in case the skier falls.** As an example, your boat traveling at 25 miles per hour (40 km/hr) in 5 seconds will overtake a fallen skier who was 200 feet in front of you.
- **Watch fallen skiers.** When using your boat for water skiing or similar activities, always keep a fallen or down skier on the operator’s side of the boat while returning to attend the skier. The operator should always have the down skier in sight and never back up to the skier or anyone in the water.
- **Report accidents.** Boat operators are required by law to file a Boating Accident Report with their state boating law enforcement agency when their boat is involved in certain boating accidents. A boating accident must be reported if (1) there is loss of life or probable loss of life, (2) there is personal injury requiring medical treatment beyond first aid, (3) there is damage to boats or other property where the damage value exceeds \$500.00 or (4) there is complete loss of the boat. Seek further assistance from local law enforcement.

CA282

Protecting People In The Water

While You Are Cruising

It is very difficult for a person standing or floating in the water to take quick action to avoid a boat heading in his/her direction even at slow speed.

Always slow down and exercise extreme caution any time you are boating in an area where there might be people in the water.

Whenever a boat is moving (coasting) and the drive unit is in neutral position, there is sufficient force by the water on the propeller to cause the propeller to rotate. This neutral propeller rotation can cause serious injury.

While Boat Is Stationary

Shift the drive unit into neutral and shut off the engine before allowing people to swim or be in the water near your boat.

WARNING

Stop your engine immediately whenever anyone in the water is near your boat. Serious injury to the person in the water is likely if contacted by a rotating propeller, a moving boat, a moving gear case, or any solid device rigidly attached to a moving boat or gear case.

CA283

High-Speed And High-Performance Boat Operation

If your boat is considered a high-speed or high-performance boat with which you are unfamiliar, we recommend that you never operate it at its high speed capability without first requesting an initial orientation and familiarization demonstration ride with your dealer or an operator experienced with your boat. For additional information, obtain a copy of our “Hi-Performance Boat Operation” booklet (Part Number 90-86168--3) from your dealer, distributor, or Mercury Marine.

Conditions Affecting Operation

Weight Distribution

Positioning of weight (passengers and gear) inside the boat has the following effects:

A. Shifting weight to rear (stern) will:

- Generally increases speed and engine RPM.
- At extremes, can cause boat to porpoise.
- Causes bow to bounce in choppy water.
- Increases danger of following wave splashing into boat when coming off plane.

B. Shifting weight to front (bow) will:

- Improves ease of planing on some boats.
- Improves rough water ride.
- At extremes, can cause boat to veer back and forth (bow steer).

Bottom Of Boat

To maintain maximum speed, the following conditions of the boat bottom should be observed.

- A. Clean, free of barnacles and marine growth.
- B. Free of distortion; nearly flat where it contacts the water.
- C. Straight and smooth, fore and aft.

Marine vegetation may accumulate when boat is docked. This growth must be removed before operation; it may clog water inlets and cause engine to over heat.

Cavitation

Cavitation occurs when water flow cannot follow the contour of a fast-moving underwater object, such as a gear housing or propeller. Cavitation permits the propeller to speed up, but the boat speed to reduce. Cavitation can seriously erode the surface of the gear housing or propeller. Common causes of cavitation are:

- A. Weeds or other debris snagged on propeller or gear housing.
- B. Bent propeller blade or damaged gear housing skew .
- C. Raised burrs or sharp edges on propeller or gear housing.

Ventilation

Ventilation is caused by surface air or exhaust gases which are introduced around the propeller resulting in propeller speedup and a reduction in boat speed. Excessive ventilation is annoying and usually caused by:

- A. Drive unit trimmed out too far.
- B. A missing propeller diffuser ring.
- C. A damaged propeller or gear housing, which allows exhaust gases to escape between propeller and gear housing.
- D. Drive unit installed too high on transom.

Propeller Selection

IMPORTANT: Installed propeller must allow engine to run at its specified maximum wide-open-throttle revolutions per minute (RPM). Use an accurate service tachometer to verify engine operating RPM.

It is the responsibility of the boat manufacturer and/or the selling dealer to equip the power package with the correct propeller(s). Specified engine wide-open-throttle (WOT) and operating RPM range are listed in "SPECIFICATIONS".

IMPORTANT: The engines covered in this manual are equipped with a governor that limits engine RPM. Be sure that propeller being used does not allow engine to run against the governor, as a significant loss in performance will result.

Engine RPM - Governor Limit		
MCM Model	Engine Recommended Operating RPM Range	Governor RPM Setting (Begins At:)
D3.6L/180	3600-3800	3830
D4.2L/220	3400-3600	3630
D2.8L D-Tronic	3600-3800	3875
D4.2L D-Tronic		

Select a propeller that will allow the engine power package to operate at or near the top end of the recommended wide-open-throttle operating RPM range with a normal load. High RPM, caused by an excessive trim angle, should not be used in determining correct propeller selection.

If full throttle operation is below the recommended range, the propeller must be changed to prevent loss of performance and possible engine damage. On the other hand, operating an engine above the recommended operating RPM range will cause higher than normal wear and/or damage. Generally, there is a 200 RPM change between propeller pitches.

After initial propeller selection, the following common problems may require that the propeller be changed to a lower pitch:

- Warmer weather and greater humidity cause an RPM loss.
- Operating in a higher elevation causes an RPM loss.
- Operating with a damaged propeller or dirty boat bottom causes an RPM loss.
- Operating with increased load (additional passengers, pulling skiers, etc.)

For better acceleration, such as is needed for water skiing, use the next lower pitch propeller. However, do not operate at full throttle when using the lower pitch propeller but not pulling skiers.

How Elevation And Climate Affect Performance

Elevation has a very noticeable effect on the wide-open-throttle power of an engine. Since air (containing oxygen) gets thinner as elevation increases, the engine begins to starve for air. Humidity, barometric pressure and temperature do have a noticeable effect on the density of air. Heat and humidity thin the air. This condition can become particularly annoying when an engine is propped out on a cool, dry day in spring and later, on a hot, sultry day in August, doesn't have its old zip.

Although some performance can be regained by dropping to a lower-pitch propeller, the basic problem still exists. In some cases, a gear-ratio change to more reduction is possible and very beneficial.

Summer conditions of high temperature, low barometric pressure and high humidity all combine to reduce the engine power. This, in turn, is reflected in decreased boat speeds, as much as 2 or 3 miles per hour in some cases. Nothing will regain this speed for the boater, but the coming of cool, dry weather.

In pointing out the practical consequences of weather effects, an engine -- running on a hot, humid summer day -- may encounter a loss of as much as 14% of the horsepower it would produce on a dry brisk spring or fall day. With the drop in available horsepower, this propeller will, in effect, become too large. Consequently, the engine operates at less than its recommended RPM. This will result in further loss of horsepower at the propeller with another decrease in boat speed. This secondary loss, however, can be somewhat regained by switching to a lower-pitch propeller that allows the engine to again run at recommended RPM.

For boaters to realize optimum engine performance under changing weather conditions, it is essential that the engine be propped to allow it to operate at or near the top end of the recommended maximum RPM range at wide-open-throttle with a normal boat load.

Not only does this allow the engine to develop full power, but equally important is the fact that the engine also will be operating in an RPM range that discourages damaging detonation. This, of course, enhances overall reliability and durability of the engine.

Operation And Maintenance

RECOMMENDED OPERATION/DUTY CYCLE

It is the operator's responsibility to operate within the following recommended operational capability, or duty cycle, as applicable to engine and installation:

- Pleasure Duty -
 - 1.) Operated at rated power and rated speed for short periods of time.
- Light Duty -
 - 1.) Operated such that full rated power at maximum rated RPM is limited to 10% of operating time and continuous cruising RPM is limited to 90% of Wide-Open-Throttle RPM (when propped within specified RPM range).
 - 2.) Annual operating time is not to exceed 500 hours.

NOTE: *Pleasure duty rating applies to high performance-type boats, or boats with planing hulls where acceleration and top speed are of primary importance. This rating is reserved for privately-owned yachts, or recreational power boats in non-revenue applications.*

Light duty rating applies to planing boats where the use of full rated power at maximum rated RPM is limited (as stated above). Examples of Light Duty applications include, but are not limited to: search and rescue craft, fast patrol boats, fire boats, dive boats, and limited season fishing boats such as sport-fish charter boats. Application to common commercial crafts having full-displacement or semi-displacement hulls exceeds the recommended operational capability, or duty cycle.

IMPORTANT: **Damage caused by improper application or failure to operate within the operational capability, or duty cycle, will not be covered by the MerCruiser Diesel Limited Warranty.**

CE7

OWNER/OPERATOR RESPONSIBILITIES

It is the operator's responsibility to perform all safety checks, ensure that all lubrication and maintenance instructions are complied with for safe operation, and return the unit to an Authorized MerCruiser Dealer for a periodic checkup.

Normal maintenance service and replacement parts are the responsibility of the owner/operator and as such, are not considered defects in workmanship or material within the terms of the warranty. Individual operating habits and usage contribute to the need for maintenance service.

Proper maintenance and care of your power package will assure optimum performance and dependability, and will keep your overall operating expenses at a minimum. See your Authorized MerCruiser Dealer for service aids.

▲ CAUTION

The injection pump lever Wide-Open-Throttle (W.O.T.) Stop Screw adjusts the engine speed governor, and is factory set and sealed. Readjusting the governed speed and operating above the specified RPM will cause extensive engine damage and/or failure. Removal of the seal and/or readjustment of the governed speed is considered misuse of engine, and resulting damages will not be covered by the limited warranty.

CA14

DEALER RESPONSIBILITIES

In general, a dealer's responsibilities to the customer include predelivery inspection and preparation such as:

- Make sure that the boat is properly equipped.
- Prior to delivery, make certain that the MerCruiser power package and other equipment are in proper operating condition.
- Make all necessary adjustments for maximum efficiency.
- Familiarize the customer with the on-board equipment.
- Explain and demonstrate the operation of the power package and boat.
- At the time of delivery, the dealer should provide you with a copy of a Predelivery Inspection Checklist.
- Your selling dealer should fill out the Warranty Registration Card completely and mail it to the factory (branch or distributor) immediately upon sale of the new product.

Freezing Temperature And Cold Weather Operation

IMPORTANT: If boat is operated during periods of freezing temperature, precautions must be taken to prevent freezing damage to power package. Refer to the following and to “Cold Weather or Extended Storage” for related information and draining instructions. Damage caused by freezing **IS NOT** covered by the MerCruiser Limited Warranty.

⚠ CAUTION

Seawater (raw water) section of cooling system MUST BE COMPLETELY drained for winter storage or immediately after cold weather use, if the possibility of freezing temperatures exist. Failure to comply may result in trapped water causing freeze and/or corrosion damage to engine.

In order to operate the engine in temperatures of 32° F (0° C) or lower, observe the following instructions:

- At the end of each daily operation, COMPLETELY drain seawater section of cooling system to protect against damage by freezing.
- At the end of each daily operation, drain water from water separator, if equipped. Fill fuel tank at end of daily operation to prevent condensation.
- Use required permanent-type antifreeze solution to protect components against damage by freezing.
- Be sure to use proper cold weather lubrication oil, and be sure the crankcase contains a sufficient amount.
- Make certain that the battery is of sufficient size and is fully charged. Check that all other electrical equipment is in optimum condition.
- If operating in arctic temperatures of –20° F (–29° C) or lower, consult your dealer for information about special cold weather equipment and precautions.

Drive Unit Impact Protection

The Power Trim hydraulic system is designed to provide impact protection for drive unit. If a submerged object is struck while boat is moving forward, the hydraulic system will cushion kick-up of drive unit as it clears the object, reducing damage to unit. After drive unit has cleared object, the hydraulic system allows drive unit to return to original operating position, preventing loss of steering control and engine over speed.

Use extreme caution when operating in shallow water or where underwater objects are known to be present. Use extreme care to prevent striking submerged objects while operating in REVERSE. No impact protection is provided in REVERSE.

If drive unit should strike a submerged object, stop engine as soon as possible and inspect drive unit for damage. If damage is present or suspected, boat should be taken to an Authorized MerCruiser Dealer for thorough inspection and necessary repair. Operating a damaged drive unit could cause additional damage to other parts of drive unit, or could affect control of boat. If continued running is necessary, do so at greatly reduced speeds.

IMPORTANT: Impact protection system cannot be designed to ensure total protection from impact damage under all conditions.

Drain Plug and Bilge Pump

The engine compartment in your boat is a natural place for water to collect. For this reason, boats are normally equipped with a drain plug and/or a bilge pump. It is very important to check these items on a regular basis to ensure that the water level does not rise to come in contact with your power package. Components on your engine will be damaged if submerged. Damage caused by submersion is not covered by the MerCruiser Limited Warranty.

CA20

Launching and Boat Operation Care

CAUTION

During launching from a trailer, if the unloading ramp is steep or the trailer bed must be tilted, the boat may enter the water rapidly and at a steep angle. This may force water through the exhaust system into the cylinders. The more weight on the transom, the more likely this is to occur.

Slowing down rapidly, stopping suddenly or backing up rapidly may cause a following wave to “swamp” the transom causing water to enter the cylinders through the exhaust system causing severe engine damage.

When backing up rapidly, the same situation may occur as stated in the preceding paragraph.

In any of these situations, water entering the engine could cause severe damage to internal parts. Refer to “Attention Required After Submersion,” in this “Operation and Maintenance Manual.”

CA18

Attention Required After Submersion

- Before recovery, contact an Authorized MerCruiser Dealer.
- After recovery, immediate service by an Authorized MerCruiser Dealer is required to prevent serious damage to power package.

CA19

Trailing Boat

Boat can be trailered with drive unit in up or down position. Adequate road clearance is required between road and gear housing skew when trailering with drive unit in down position.

If adequate road clearance is a problem, place drive unit in full trailer position and support with an optional trailer kit which is available from your Authorized MerCruiser Dealer.

CA21

Stolen Power Package

If your power package is stolen, immediately advise the local authorities and Mercury Marine of the model and serial number(s) and to whom the recovery is to be reported. This “Stolen Motor” information is placed into a file at Mercury Marine to aid authorities and dealers in recovery of stolen motors.

CE9

Replacement Service Parts

Marine engines are expected to operate at or near full throttle for most of their life. They are also expected to operate in both fresh and saltwater environments. These conditions require numerous special parts. Care should be exercised when replacing marine engine parts, as specifications are quite different from those of the standard automotive engine.

Since marine engines must be capable of running at or near maximum RPM much of the time, special pistons, camshafts and other heavy-duty moving parts are required for long life and peak performance.

These are but a few of the many special modifications that are required in MerCruiser marine engines to provide long life and dependable performance.

CA410

Do-It-Yourself Maintenance Suggestions

If you are one of those persons who likes to do-it-yourself, here are some suggestions for you.

- Present-day marine equipment, such as your MerCruiser power package, are highly technical pieces of machinery. Electronic ignition and special fuel delivery systems provide greater fuel economies, but also are more complex for the untrained mechanic.
- Do not attempt any repairs which are not covered in this manual unless you are aware of the precautions (“Cautions” and “Warnings”) and procedures required. Your safety is of our concern.
- If you attempt to service the product yourself, we suggest you order the maintenance procedures manual for that model. This manual outlines the correct procedures to follow. Do not attempt repairs if you do not understand the procedures.
- There are special tools and equipment that are required to perform some repairs. Do not attempt these repairs unless you have these special tools and/or equipment. You can cause damage to the product in excess of the cost a dealer would charge you.
- Also, if you partially disassemble an engine or drive assembly and are unable to repair it, the dealer's mechanic must reassemble the components and test to determine the problem. This will cost you more than taking it to the dealer immediately upon having a problem. It may be a very simple adjustment to correct the problem.
- Do not telephone the dealer, service office or the factory to attempt for them to diagnose a problem or request the repair procedure. It is difficult for them to diagnose a problem over the telephone.
- Your Authorized Dealer is there to service your power package. They have qualified factory-trained mechanics.

It is recommended you have the dealer do periodic maintenance checks on your power package. Have them winterize it in the fall and service it before the boating season. This will reduce the possibility of any problems occurring during your boating season when you want trouble-free boating pleasure.

CD329

Diagnosing EDI Problems (If So Equipped)

Your Authorized MerCruiser Dealer has the proper service tools for diagnosing problems on Electronic Diesel Injection (EDI) Systems. The Electronic Control Module (ECM) on these engines have the ability to detect some problems with the system when they occur, and store a “Trouble Code” in the ECM's memory. This code can then be read later by a service technician using a special diagnostic tool.

Engine Break-In

INITIAL BREAK-IN PROCEDURE

It is especially important that the following procedure be used on new diesel engines. This break-in procedure allows the proper seating of the pistons and rings, which greatly reduces the likelihood of problems.

IMPORTANT: It is recommended that the boat not be accelerated hard until this procedure has been completed.

IMPORTANT: Never operate the starter motor longer than 15 seconds at a time, to avoid overheating the starter motor. If engine does not start, wait 1 minute to allow the starter motor to cool; then, repeat starting procedure.

Initial Break-in Procedure Is As Follows:

1. Follow instructions “a” or “b”:
 - a. **On D2.8L D-Tronic and D4.2L D-Tronic Engines:** Proceed to Step2.
 - b. **On D3.6L/180 and D4.2L/220 Engines Only:** Pre-lubricate the turbocharger and engine. To do this, hold the “STOP” switch toggle lever DOWN while you simultaneously turn the key switch to “START” position for 15 seconds. This will rotate the starter motor and engine/oil pump. During this process the engine will not run because no fuel is injected. Allow the starter motor to cool down for one minute and repeat the above described process. To avoid overheating the starter motor, do not engage starter motor for more than 15 seconds each time.
2. Refer to appropriate “Starting, Shifting and Stopping” section and start engine. Allow engine to idle until it has reached normal operating temperature.
3. Run engine in gear for 3 minutes at each of the following RPMs: 1200 RPM, 2400 RPM and 3000 RPM.
4. Run engine in gear for 3 minutes at each of the following RPMs: 1500 RPM, 2800 RPM and 3400 RPM.
5. Run engine in gear for 3 minutes at each of the following RPMs: 1800 RPM, 3000 RPM and Maximum Rated Full-Throttle RPM.

20-HOUR BREAK-IN PERIOD

IMPORTANT: The first 20 hours of operation is the engine break-in period. Correct break-in is essential to obtain minimum oil consumption and maximum engine performance. During this break-in period, the following rules must be observed:

- DO NOT operate engine below 1500 RPM for extended periods during the first 10 hours. During this period, shift into gear as soon as possible after starting engine and advance throttle so that RPM is above 1500 (provided that conditions permit safe operation at this speed).
- DO NOT operate at any one constant speed for extended periods.
- DO NOT exceed 75% of full throttle during the first 10 hours except during engine Initial Break-In Procedure. During the next 10 hours, occasional operation at full throttle (5 minutes at a time maximum) is permissible.
- AVOID full throttle acceleration from stopped position.
- DO NOT operate at full throttle until engine reaches normal operating temperature.
- OBSERVE INSTRUMENTS, if an abnormal reading occurs, stop engine immediately and determine cause.
- FREQUENTLY CHECK crankcase oil and stern drive unit fluid levels. Add if necessary. It is normal for oil consumption to be somewhat high during the break-in period.
- AT END OF 20-HOUR break-in period, remove break-in oil and replace oil filter. Fill crankcase with correct grade and viscosity oil.

After Break-In Period

To help extend the life of your MerCruiser power package, the following recommendations should be considered;

- Use a propeller that allows the engine to operate at or near the top of the maximum RPM range (See “Specifications” section) when at full throttle with a normal boat load.
- Operation at 3/4 throttle setting or lower is recommended. Refrain from prolonged operation at maximum (full throttle) RPM.

End of First Season Checkup

At the end of the first season of operation, an Authorized MerCruiser Dealer should be contacted to discuss and/or perform various scheduled maintenance items. If you are in an area where the product is operated continuously (year-round operation), you should contact your dealer at the end of the first 100 hours of operation, or once yearly, whichever occurs first.

Specifications

CD11

Seacock

Seacock (water inlet valve) used, must have an internal cross-sectional area equal to or greater than hose to prevent restricting water flow. A 1-1/2 in. (38mm) brass ball or gate valve is minimum required.

Seacock should be installed in an area where it is easily accessible and supported adequately to prevent hose fatigue.

CE14

Seawater Strainer

Seawater Strainer should be provided, and be of sufficient size to ensure that an adequate supply of water will be maintained for cooling engine. A minimum flow rate of 40 gallons (150 litres) per minute is required.

Strainer should be installed in an area where it will be easily accessible for inspection and cleaning. Strainer should be installed in water inlet hose after seacock to allow operator to shut off water inlet when cleaning strainer.

CD164

Fuel Requirements

WARNING

Electrical system components on this engine are not external ignition protected. **DO NOT STORE OR UTILIZE GASOLINE ON BOATS EQUIPPED WITH THESE ENGINES, UNLESS PROVISIONS HAVE BEEN MADE TO EXCLUDE GASOLINE VAPORS FROM ENGINE COMPARTMENT (REF: 33 CFR).** Failure to comply could result in fire, explosion and/or severe personal injury.

WARNING

FIRE HAZARD: Fuel leakage from any part of the fuel system can be a fire hazard which can cause serious bodily injury or death. Careful periodic inspection of entire fuel system is mandatory, particularly after storage. All fuel components including fuel tanks, whether plastic, metal or fiberglass, fuel lines, primers, fittings, and fuel filters should be inspected for leakage, soften, hardening, swelling or corrosion. Any sign of leakage or deterioration requires replacement before further engine operation.

IMPORTANT: Use of improper or water contaminated diesel fuel can damage your engine seriously. Use of improper fuel is considered misuse of engine, and damage caused thereby will not be covered by warranty.

WARNING

Under *no circumstances* should gasoline, gasohol and/or alcohol be mixed with diesel fuel for any reason. This mixture of gasoline, gasohol and/or alcohol with diesel fuel is highly flammable and produces a significant risk to the user.

Grade 2-D diesel fuel is required, meeting ASTM Standards D975 (or fuel rated Diesel DIN 51601), and having a minimum cetane rating of 45.

The Cetane number is a measure of the ignition quality of diesel fuel. Increasing the cetane number will not improve overall engine performance, but it may be necessary to raise the cetane rating for low temperature, or high altitude use. A lower cetane number could cause hard starting and slower warm-up, and could increase engine noise and exhaust emissions.

NOTE: *If your engine suddenly becomes noisy after a fuel fill, you possibly received substandard fuel with a low cetane rating.*

Sulphur content of the above fuel is rated at 0.50% by weight, maximum (ASTM). Limits may vary in countries outside of the United States.

On intermittent use engines, high sulphur content diesel fuel will greatly increase:

- Corrosion on metal parts.
- Deterioration of elastomer and plastic parts.
- Corrosion and extensive damage, and excessive wear of internal engine parts, particularly bearings.
- Starting and operating difficulties.

CE16

Diesel Fuel In Cold Weather

Unaltered diesel fuels thicken and “gel” in cold temperatures, unless treated. Virtually all diesel fuels are “climatized” to allow their use in the particular region for that time of the year. If it becomes necessary to further treat diesel fuel, it is the owner/operator’s responsibility to add a commercial “standard brand” “anti-gel” diesel fuel additive, following that product’s directions.

CD331

Crankcase Oil

To help obtain optimum engine performance and to provide maximum protection, the engine requires engine oil with a rating of HD-SAE-API SH, CF/CF-2.

We strongly recommend the use of QUICKSILVER 4-Cycle Marine Engine Oil, a specially blended 25W-40 SH, CF/CF-2 oil with Marine Additives, for all temperature operations.

RECOMMENDED OILS FOR D4.2L/220, D2.8L D-TRONIC AND D4.2L D-TRONIC ENGINES

ALL TEMPERATURE OPERATION - USE 15W-40		
These oils, approved by Mercury Marine and Marine Power Europe, exceed MIL-2104 D standards.		
AGIP SIGMA TURBO	MOBIL DELVAC 1400 SUPER	TOTAL RUBIA TIR
SHELL MYRINA	TEXACO URSA SUPER TD	VEEDOL TURBOBOSTAR
MOPAR	WINTERSHALL MULTI-REKORD	WINTERSHALL VIVA 1

RECOMMENDED OILS FOR D3.6L/180 ENGINES

ALL TEMPERATURE OPERATION - USE 15W-40		
These oils, approved by Mercury Marine and Marine Power Europe, exceed MIL-2104 D standards.		
AGIP SIGMA TURBO	CHEVRON DELO 450 MOTOR OIL	FANAL INDOL X
ARAL OL P 327	MULTIGRADE	FINA KAPP LDO
AUTOL VALVE-SHP	DEUSOL TURBOMAX	FUCHS TITAN TRUCK 1540
AVIATICON TURBO	DIVINOL MULTIMAX EXTRA	GULF SUPERFLEET SPECIAL
BP VANELLUS C3 EXTRA	DUKCHAMS HYPERGRADE	IP TAURUS M
CALTEX RPM DELO 450 OIL	ECUBSOL OIL CD PLUS	MOBIL DELVAC 1400 SUPER
CASTROL TURBOMAX	ELF MULTIPERFORMANCE	TOTAL RUBIA TIR
CENTURY SHPD	ESSO HESSOL TURBODIESEL	VALVOLINE SUPER HD LD

Engine Specifications

(D3.6L/180 and D4.2L/220)

DESCRIPTION		SPECIFICATION MCM (Stern Drive)	
		D3.6L/180	D4.2L/220
Crankshaft Horsepower (Kilowatts) ¹		180 (134)	220 (164)
Propeller Shaft Horsepower (Kilowatts) ¹		170 (127)	200 (149)
Engine Type		In-Line 6 Cylinder Diesel	
Displacement		219 cu. in. (3.6 L)	254 cu. in. (4.2 L)
Firing Order		1 - 5 - 3 - 6 - 2 - 4	
Bore		3.622 in. (92mm)	3.700 in. (94mm)
Stroke		3.543 in. (90mm)	3.937 in. (100mm)
Compression Ratio		22:1	21.5:1
Valve Clearance - Intake / Exhaust		.012 in. (0.30 mm)	
Maximum Pressure Difference Between Cyl.		72 PSI (500 kPa)	
Maximum Governed WOT RPM		4300 ± 50	4200 ± 50
Maximum WOT RPM		3800	3600
Idle RPM in Forward Gear		750	
Oil Pressure:	750 RPM	22-36 PSI [1.5 - 2.5 bar (152-248 kPa)]	
	3600 RPM	50-58 PSI [3.5 - 4 bar (345-400 kPa)]	
Oil Temperature		212° - 230° F (100° - 110° C)	
Thermostats:	Water: (2 Total) 1 at temp. :	160° F (70° C)	
	1 at temp. :	180° F (82° C)	
	Oil: (1 Total)	203° F (95° C)	
Coolant Temperature		176° - 185° F (80° - 85° C)	
Electrical System		12-volt Negative (-) Ground	
Alternator Rating		949W, 14.6v, 65A	
Recommended Battery Rating		750 cca, 950 mca, or 180 Ah	
Starter		12v, 2.7 kW	

¹ Power rated in accordance with NMMA Procedure - ISO 3046 (Technically Identical to ICOMIA 28-83).

CE20

Required Coolant: Quicksilver Premixed Marine Engine Coolant

IMPORTANT: This contains special low silicate ethylene glycol, special additives, and purified water. Use of other coolant may cause fouling of the heat exchangers, and overheating of the engine.

Engine Specifications

(D2.8L D-Tronic and D4.2L D-Tronic)

DESCRIPTION	SPECIFICATION MCM (Stern Drive)	
	D2.8L D-Tronic	D4.2L D-Tronic
Crankshaft Horsepower (Kilowatts) ¹	165 (123)	250 (186)
Propeller Shaft Horsepower (Kilowatts) ¹	150 (112)	225 (168)
Engine Type	In-Line 4 Cylinder Diesel	In-Line 6 Cylinder Diesel
Displacement	169 cu. in. (2.8 L)	254 cu. in. (4.2 L)
Firing Order	1 - 3 - 4 - 2	1 - 5 - 3 - 6 - 2 - 4
Bore	3.700 in. (94mm)	3.700 in. (94mm)
Stroke	3.937 in. (100 mm)	3.937 in. (100mm)
Compression Ratio	16.5:1	16.5:1
Valve Clearance - Intake / Exhaust	Hydraulic	Hydraulic
Maximum Pressure Difference Between Cyl.	72 PSI (500 kPa)	
Maximum Governed RPM ²	4200 ± 50	4200 ± 50
RPM at Wide-Open-Throttle ²	3800	3800
Idle RPM in Forward Gear	750	
Oil Pressure:	750 RPM	22-36 PSI [1.5 - 2.5 bar (152-248 kPa)]
	3600 RPM	50-58 PSI [3.5 - 4 bar (345-400 kPa)]
Oil Temperature	212° - 230° F (100° - 110° C)	
Thermostats:	Water: (2 Total) 1 at temp. :	160° F (70° C)
	1 at temp. :	180° F (82° C)
	Oil: (1 Total)	203° F (95° C)
Coolant Temperature	176° - 185° F (80° - 85° C)	
Electrical System	12-volt Negative (-) Ground	
Alternator Rating	949W, 14.6v, 65A	
Recommended Battery Rating	750 cca, 950 mca, or 180 Ah	
Starter	12v, 2.7 kW	

¹ Power rated in accordance with NMMA Procedure - ISO 3046 (Technically Identical to ICOMIA 28-83).

² Refer to "Conditions Affecting Operation - Propeller Selection" for additional information.

CE20

Required Coolant: Quicksilver Premixed Marine Engine Coolant

IMPORTANT: This contains special low silicate ethylene glycol, special additives, and purified water. Use of other coolant may cause fouling of the heat exchangers, and overheating of the engine.

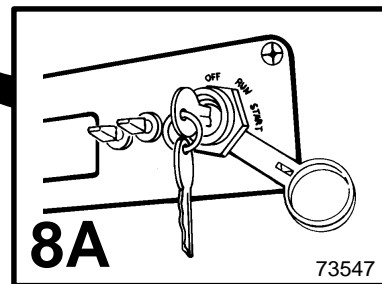
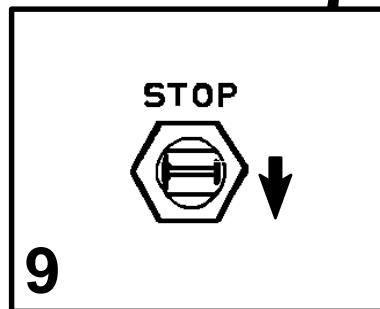
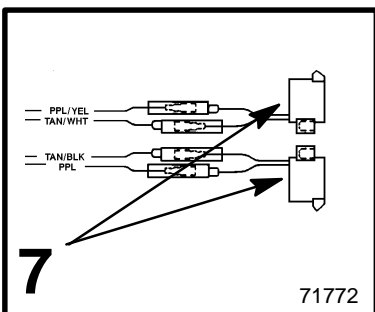
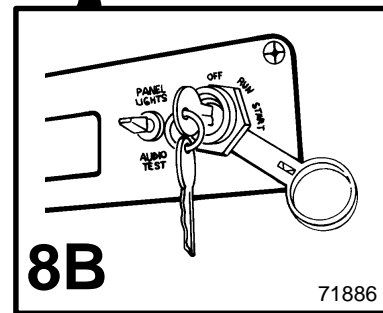
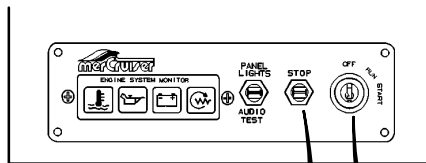
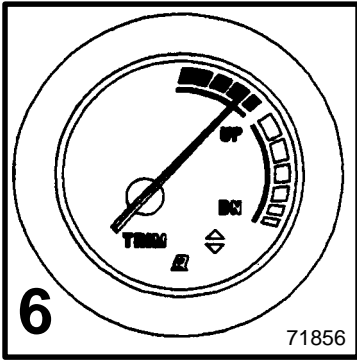
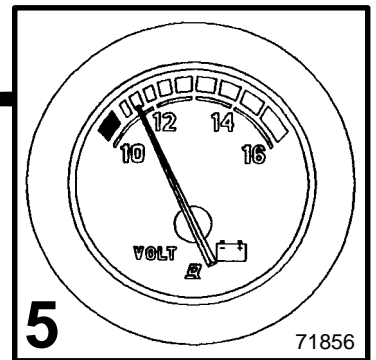
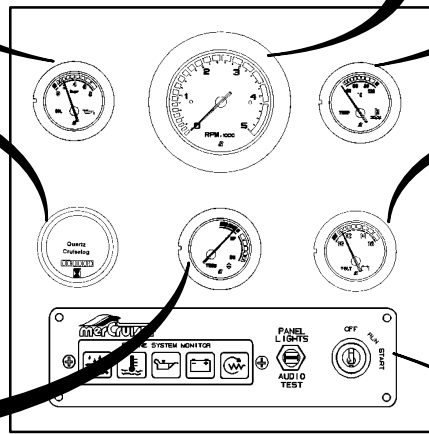
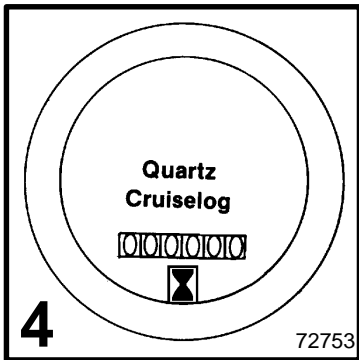
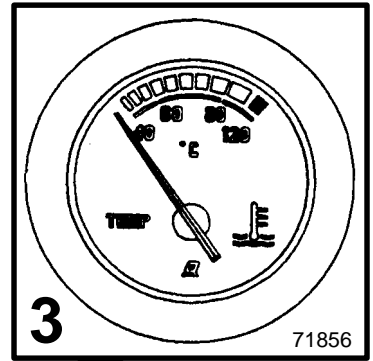
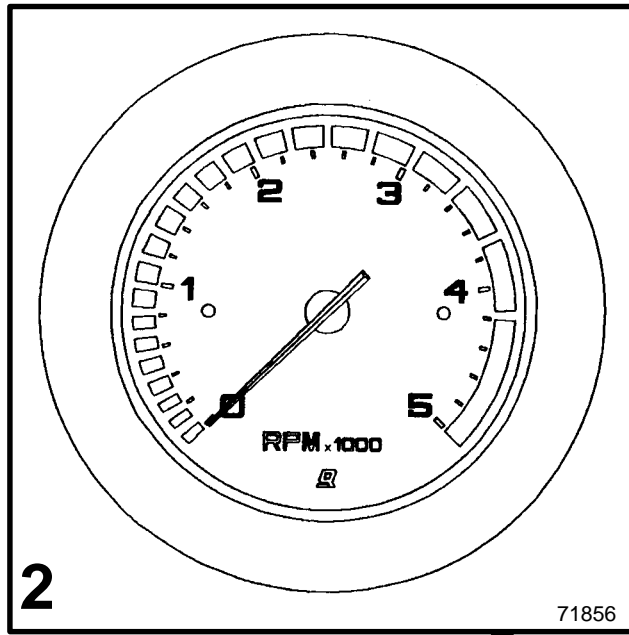
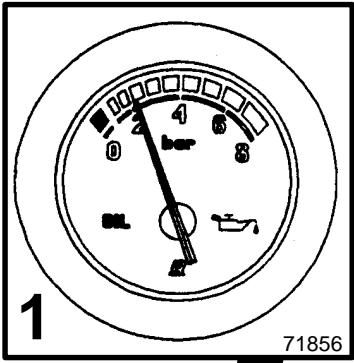

Operation

CD335

Quicksilver Instruments and Instrumentation

Shown is the basic Quicksilver instrumentation and engine system monitor display for the Diesel Power Package. The instrumentation shown is required for safe operation of boat and engine. Operator should become familiar with all instrumentation before operating the engines.

Gauges and engine system monitor panel may be individually mounted, or collectively mounted in the optional single panel available from Quicksilver.

NOTE: Refer to manufacturer's instructions and explanations about instrumentation, if equipped with other than Quicksilver instrumentation.

- 1 Oil Pressure Gauge** - indicates engine oil pressure. Refer to "Specifications" for normal operating readings.
- 2 Tachometer** - indicates engine speed (RPM).
- 3 Coolant Temperature Gauge** - indicates engine coolant temperature. Refer to "Specifications" for normal operating readings.
- 4 Cruise Log (Engine Hour Meter)** - records engine running time.
- 5 Voltmeter** - indicates battery voltage, and if alternator and charging circuit are functioning properly. The green area on the gauge is the normal operating range.
- 6 Trim/Tilt Gauge** - indicates drive unit trim angle ("Up/Out" or "Down/In").
- 7 Audio Warning Buzzer Standard Features** - Buzzer sounds if:
 - (1) Cooling system temperature too high
 - (2) Oil pressure too low
 - (3) Drive unit oil too low
- 8 Key Switch** - has three positions. In the "OFF" position, all electrical circuits are off and engine cannot be started. In the "RUN" position, all electrical circuits, indicator lamps, automatic preheating (if so equipped) and all instruments are operational. In the "START" position the engine can be started.

NOTE: Key can only be removed in the "OFF" position.
- A D3.6L/180 and D4.2L/220** - If engine is running the key switch cannot be used to stop engine. The engine can only be stopped by using the Engine Stop Switch, while the Key Switch is in the "RUN" position. No electrical circuit is operational when the key switch is turned to the "OFF" position.
- B D2.8L D-Tronic and D4.2L D-Tronic** - The engine is stopped when the key switch is turned to the "OFF" position.
- 9 Engine Stop Switch - D3.6L/180 and D4.2L/220** - is used to stop the engine. This is done by electrically shutting off fuel delivery system. Stop Switch is toggled "DOWN" and held until engine stops completely. Then, key switch can be turned to the "OFF" position.

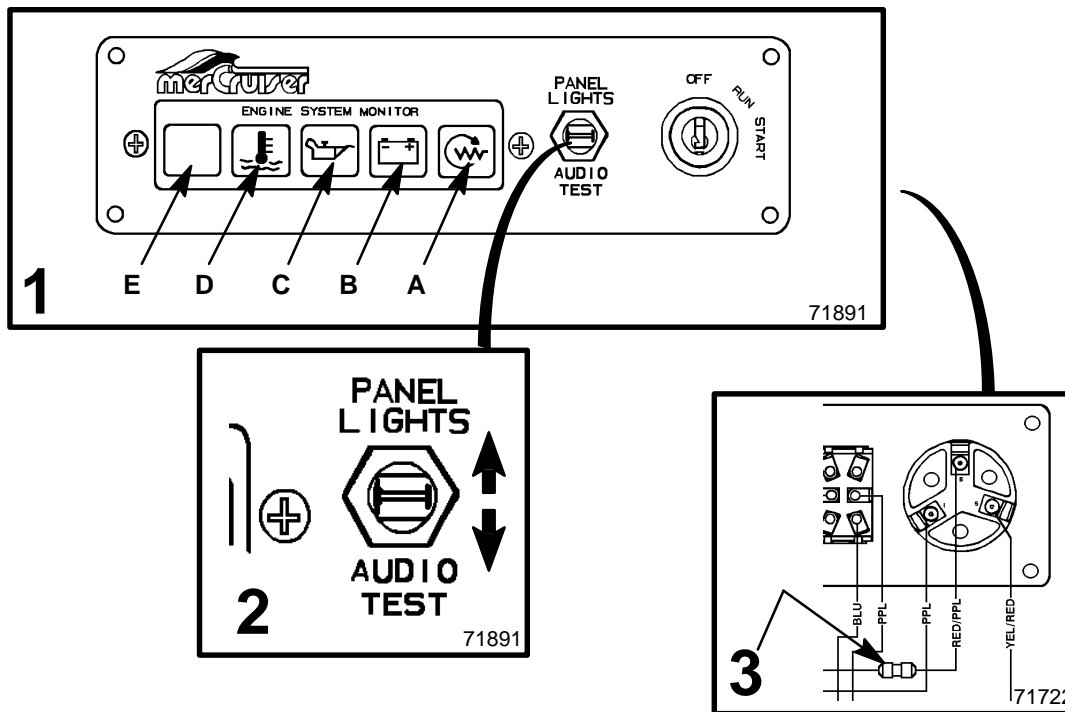

1 Engine System Monitor Features - The appropriate light functions as follows:

- A Preheat Indicator Lamp** - lights up when the glow plugs, if so equipped, are preheating the combustion chambers. The light stays on until the preheat period is complete. The timed preheat period begins when the key switch is turned on, and then, only when the engine is cold. **THE ENGINE CAN BE STARTED ONLY AFTER THE LIGHT GOES OUT.**
- B Charge Indicator Lamp** - indicates a problem with charging system if lamp illuminates while engine is running. Lamp will light when key switch is "ON" and engine is not running. When engine starts, light should go off.
- C Oil Pressure Warning Lamp** - indicates low engine oil pressure if lamp illuminates while engine is running.
- D Coolant Temperature Warning Lamp** - indicates excessive engine coolant temperature if lamp illuminates while engine is running.

NOTE: The coolant temperature warning lamp is wired in a parallel circuit with the gear lube monitor bottle switch. If lamp illuminates while engine is running, and coolant temperature and coolant level are normal, this may be an indication of low oil level in the gear lube monitor bottle. The cause should be determined and corrected.

- E Trouble Code Warning Lamp (D2.8L D-Tronic and D4.2L D-Tronic Only)** - additional lamp indicates when a problem exists that requires service, if lamp illuminates while engine is running.

2 Panel Lights / Audio Test Switch - has three positions; in the normal position all electrical circuits operate in a standard fashion (as described above). With switch toggled "UP" the instrumentation lights are all illuminated. When the switch is toggled "DOWN" the audio warning buzzer will sound allowing the operator to perform a test of the audio warning buzzer.

3 20 Amp Fuse and Holder - located in-line on key switch RED/PURPLE wire and protects the Instrumentation and wiring should an electrical overload occur. If an overload occurs, the fuse will burn out. Check "blown" (burned) fuse if key is turned to RUN or START and nothing happens.

IMPORTANT: Cause for overload must be determined and corrected before attempting to install new fuse or fuse failure will occur again.

After cause is corrected, install new fuse and check systems to function.

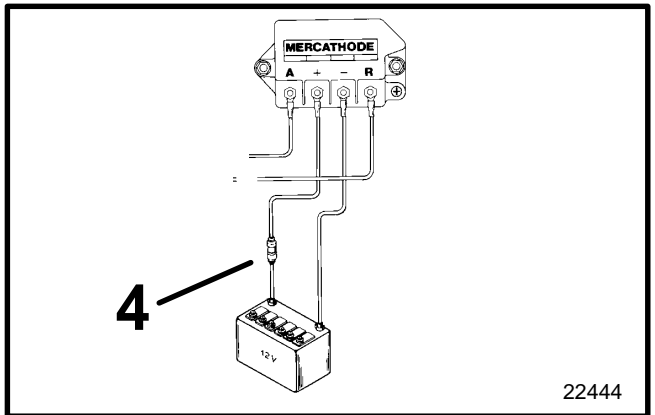
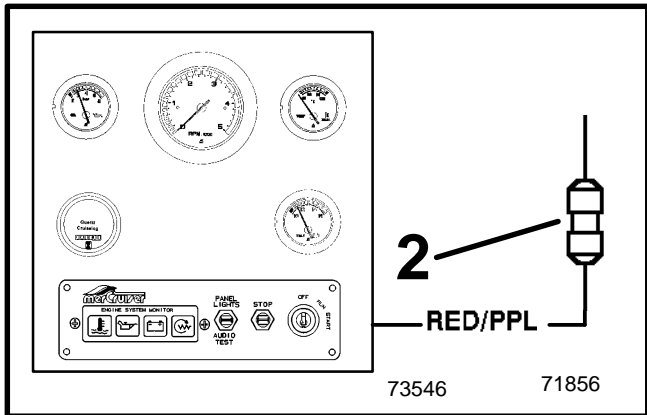
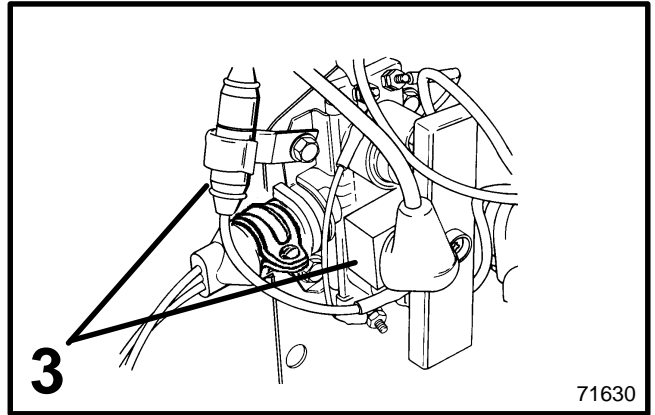
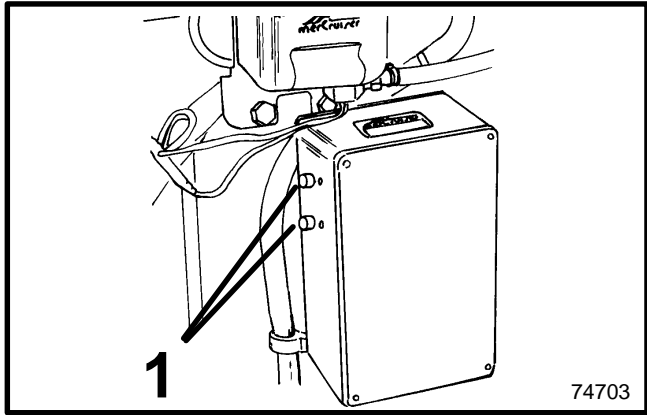

Electrical System Overload Protection

If an electrical overload occurs, a fuse will blow or a circuit breaker will trip open.

IMPORTANT: The cause must be found and corrected before replacing fuse or resetting circuit breaker.

1 Two 60 amp circuit breakers provide protection for engine wiring harness and instrumentation power lead. Reset by pushing RESET button IN (on outside).

In an emergency, when engine must be operated and cause for high current draw cannot be located and corrected, turn OFF or disconnect all accessories connected to engine and instrumentation wiring. Reset circuit breaker. If breaker remains open, electrical overload has not been eliminated. Further checks must be made on electrical system.

2 When equipped with Quicksilver instrumentation and wiring a 20 amp fuse and holder is located in-line on key switch RED/PURPLE wire and protects the Instrumentation and wiring should an electrical overload occur. If an overload occurs, the fuse will burn out. Check “blown” (burned) fuse if key is turned to RUN or START and instruments do not work and/or if switches do not function.

3 The Power Trim system is protected from overload by 110 amp fuse and a 20 amp in-line fuse on Power Trim pump.

Mercathode System

4 A 20 amp in-line fuse is in the wire which connects to positive (+) terminal on controller. If fuse is “blown” (defective), the system will not operate.

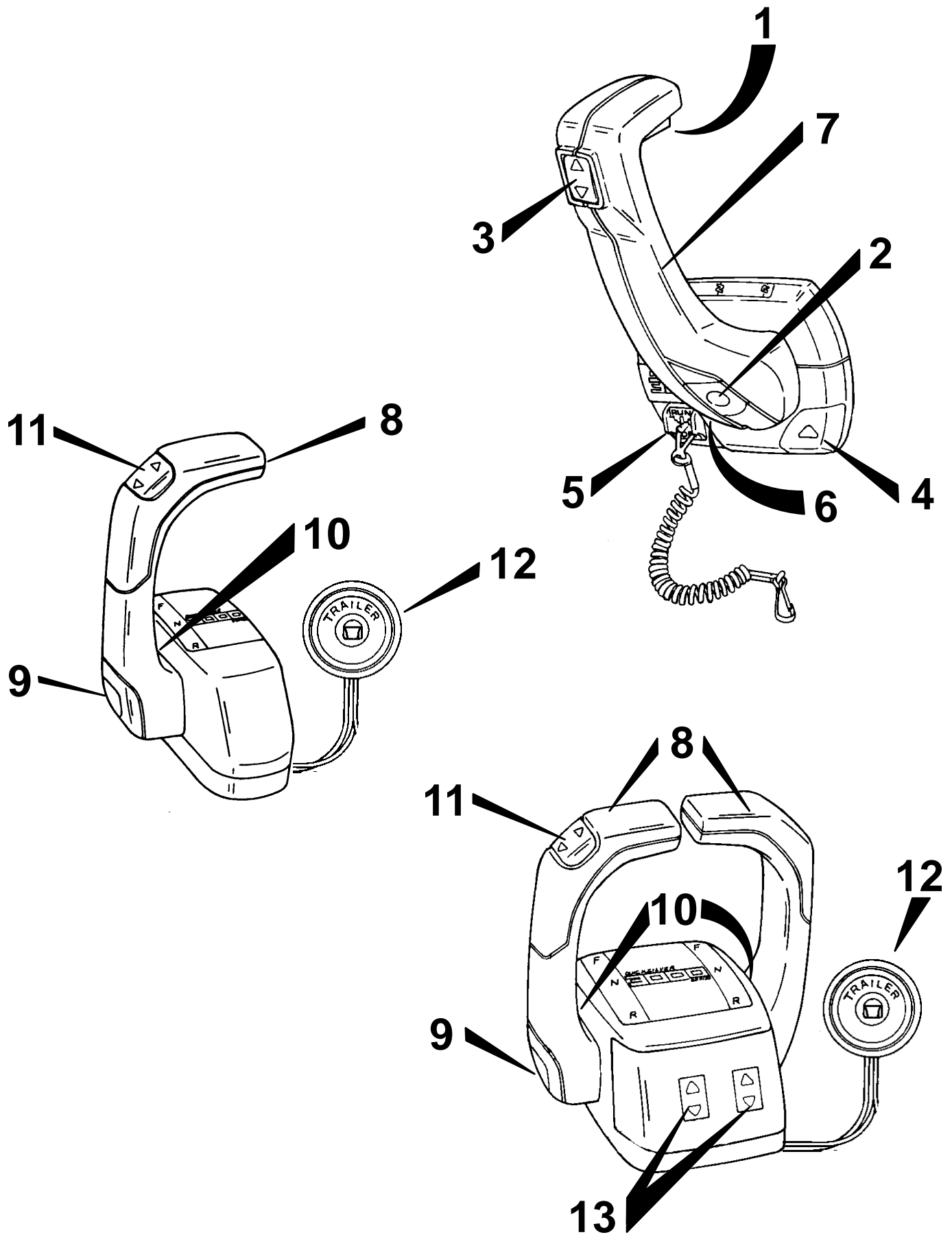

Operation

CD195

Remote Controls (Panel Mounted)

Your boat may be equipped with one of many Quicksilver® remote controls available. All controls feature an integral safety switch that allows starting engine in NEUTRAL only. Also, all controls may not have all features shown.

NOTE: *If boat is equipped with a remote control other than shown, consult your dealer for a description and/or demonstration of the control.*

- 1 Neutral Lock Bar** - Prevents accidental shift and throttle engagement. Neutral lock bar must be pulled “Up” to move the control handle out of neutral.
- 2 Throttle Only Button** - Allows engine throttle advancement without shifting the engine. This is done by disengaging the shift mechanism from the control handle. The throttle only button can be depressed only when the remote control handle is in the “Neutral” position, and should only be used to assist in starting the engine.
- 3 Power Trim Switch** - See “Power Trim” for detailed power trim operating procedures.
- 4 Trailer Switch** - Used to raise drive unit for trailering, launching, breaching or shallow water operation. See “Power Trim” for detailed trailer switch operation.
- 5 Lanyard Stop Switch** - Turns ignition “Off” whenever the operator (when attached to the lanyard) moves far enough away from the operator’s position to activate the switch. See “Lanyard Stop Switch” at the front of this manual for safety warning on the use of this switch.
- 6 Control Handle Tension Adjustment Screw** - This screw can be adjusted to “Increase” or “Decrease” the tension on the control handle. This will help prevent “Creep” of the remote control handle. Turn screw “Clockwise” to increase tension and “Counterclockwise” to decrease tension. Adjust to tension desired.
- 7 Control Handle** - Operation of the shift and throttle are controlled by the movement of the control handle. “Push” the control handle forward from “Neutral” with a quick firm motion to the first detent for “Forward” gear. Continue pushing forward to increase speed. Pull the control handle back from “Neutral” with a quick firm motion to the first detent for “Reverse” gear. Continue pushing back to increase speed.

CD196

Remote Controls (Console Mounted)

Your boat may be equipped with one of many Quicksilver® remote controls available. All controls feature an integral safety switch that allows starting engine in NEUTRAL only. Also, all controls may not have all features shown.

NOTE: *If boat is equipped with a remote control other than shown, consult your dealer for a description and/or demonstration of the control.*

- 8 Control Handle(s)** - Operation of the the shift and throttle are controlled by the movement of the control handle. “Push” the control handle forward from “Neutral” with a quick firm motion to the first detent for “Forward” gear. Continue pushing forward to increase speed. Pull the control handle back from “Neutral” with a quick firm motion to the first detent for “Reverse” gear. Continue pushing back to increase speed.
- 9 Throttle Only Button** - Allows engine throttle advancement without shifting the engine. This is done by disengaging the shift mechanism from the control handle. The throttle only button can be depressed only when the remote control handle is in the “Neutral” position, and should only be used to assist in starting the engine.
- 10 Control Handle Tension Adjustment Screw** - This screw can be adjusted to “Increase” or “Decrease” the tension on the control handle (cover must be removed to adjust). This will help prevent “Creep” of the remote control handle. Turn screw “Clockwise” to increase tension and “Counterclockwise” to decrease tension. Adjust to tension desired.
- 11 Power Trim Switch** - See “Power Trim” section for detailed power trim operating procedures.
- 12 Trailer Switch** - Used to raise drive unit for trailering, launching, breaching or shallow water operation. See “Power Trim” for detailed trailer switch operation.
- 13 Power Trim Adjustment Switches (Used on Three Button Trim Control Only)** - See “Power Trim” section for detailed power trim operating procedures.

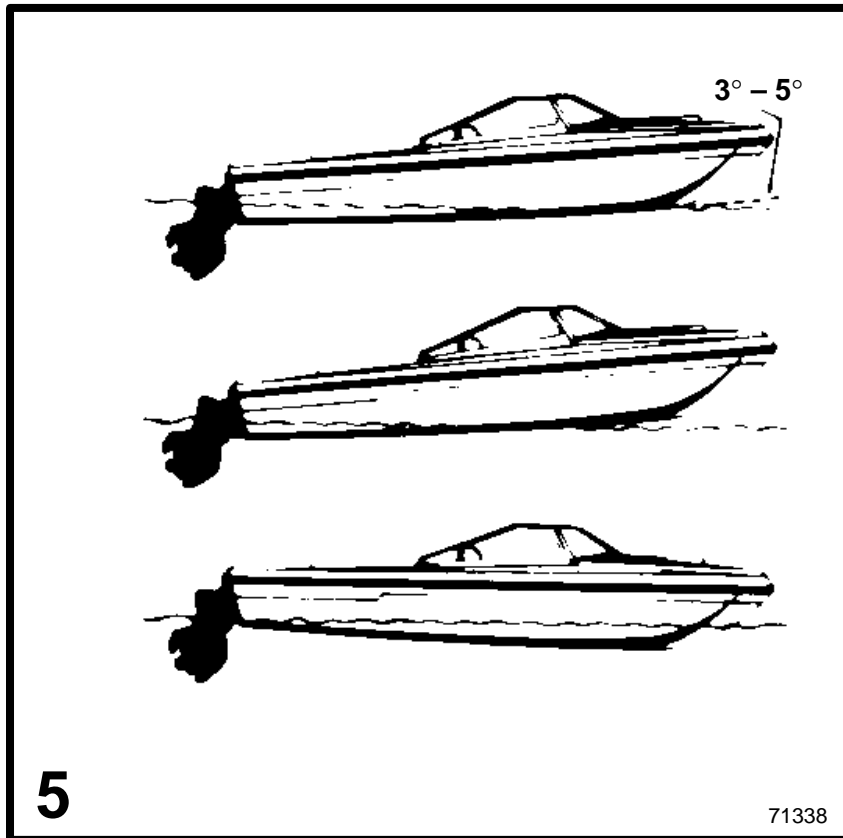
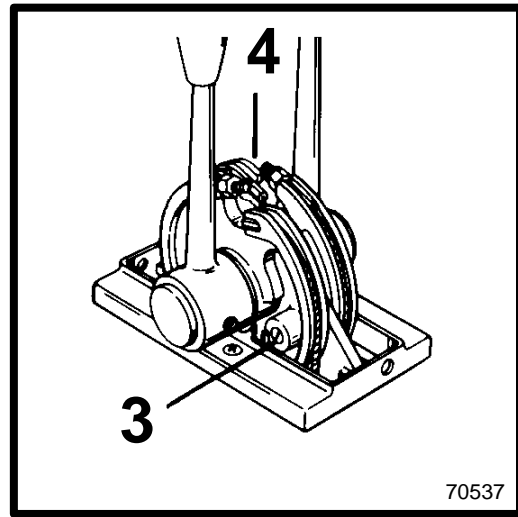
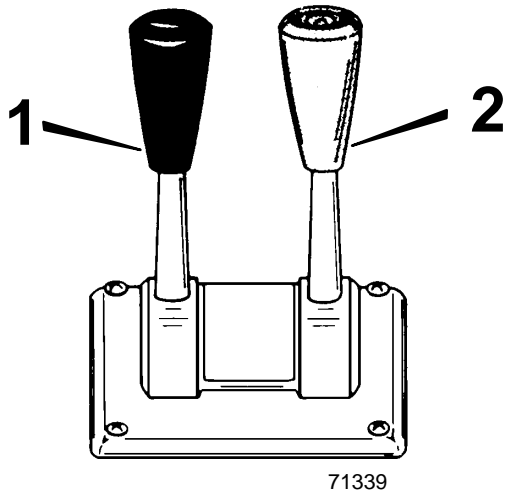

Remote Controls (Two Lever)

Your boat may be equipped with one of many Quicksilver® remote controls available. All controls feature an integral safety switch that allows starting engine in NEUTRAL only. Also, all controls may not have all features shown.

NOTE: *If boat is equipped with a remote control other than shown, consult your dealer for a description and/or demonstration of the control.*

1 Shift Lever - shifts unit into gear with full lever movement. Move lever forward to shift to FORWARD gear. Move lever backward to shift to REVERSE gear. Lever in full vertical position shifts to NEUTRAL.

⚠ CAUTION

Never shift unit into or out of gear unless throttle lever is a idle RPM.

2 Throttle Lever - allows engine RPM to be increased or decreased.

3 FRICTION Screw - adjusts control handle friction so motor speed can be set and driver does not have to hold handle.

Turn screw clockwise to increase friction. Do not thread screw all the way out.

4 DETENT Screw - controls the effort needed to move control handle out of NEUTRAL. To increase tension, turn screw clockwise; to decrease, turn screw counterclockwise. Do not thread screw all the way out.

IMPORTANT: Boats equipped with dual power packages may have both shift levers on one control and both throttle levers on the other control.

Power Trim

Power Trim allows the operator to adjust the drive angle, while underway, to provide the ideal boat angle for varying load and water conditions. Also, the Power Trim system “Trailer” feature allows the operator to raise and lower the drive unit for trailering, beaching, launching and low speed (below 1200 RPM engine speed), shallow water operation.

⚠ CAUTION

Never trim the drive unit UP/OUT using TRAILER switch while boat is underway at engine speeds above 1200 RPM. Use extreme caution when operating with drive unit raised. Severe damage to the drive unit may result if unit is raised beyond the gimbal ring support flanges at engine speeds above 1200 RPM.

5 In most cases, best overall performance is obtained with the drive unit adjusted so the boat bottom will run at a 3° to 5° angle to the water.

Trimming Drive Unit UP/OUT Can:

- Lower the bow.
- Generally increase top speed.
- Increase clearance over submerged objects or a shallow bottom.
- Cause boat to accelerate and plane off slower.
- In excess, cause boat “porpoising” (bouncing) or propeller ventilation.
- Cause engine overheating if trimmed UP/OUT to a point where any cooling water intake holes are above the water line.

Trimming Drive Unit DOWN/IN Can:

- Help the boat accelerate and plane off quicker.
- Generally improve the ride in choppy water.
- In most cases, reduce boat speed.
- If in excess, lower the bow of some boats to a point at which they begin to plow with their bow in the water while on plane. This can result in an unexpected turn in either direction called “bow steering” or “over steering” if any turn is attempted, or if a significant wave is encountered.

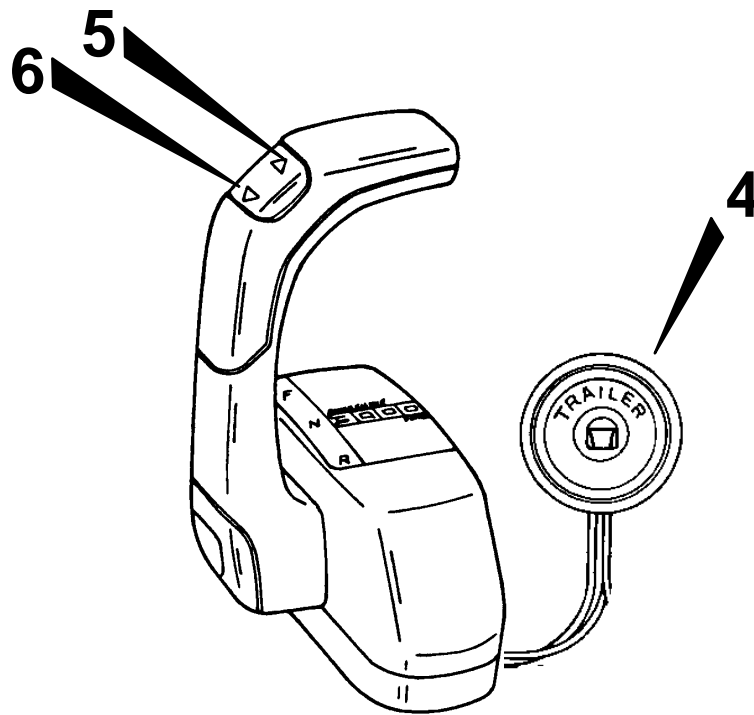
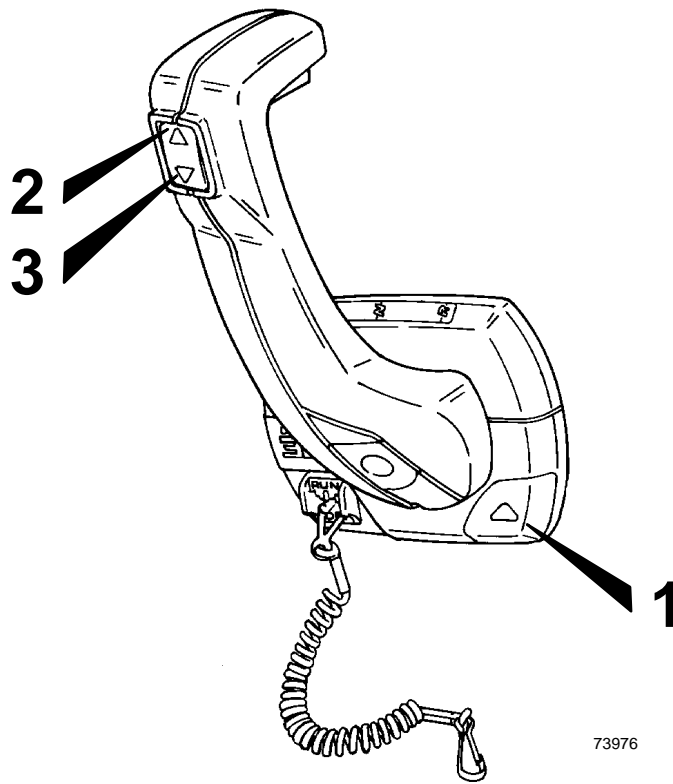

CB188

POWER TRIM OPERATION - PANEL MOUNT REMOTE CONTROL

IMPORTANT: If TRAILER button is held depressed after drive unit reaches end of upward travel, an internal circuit breaker will open and pump will stop. Should this happen, release button and allow motor to cool for about one minute. Circuit breaker will reset and Power Trim operation may be resumed.

- 1** Trailer Position: Press button until drive unit reaches desired height.
- 2** Trim Up/Out: Press UP on Trim switch until drive unit reaches desired trim position.
- 3** Lower Drive Unit: Press DOWN on Trim switch until drive unit reaches desired position.

CB189

POWER TRIM OPERATION - CONSOLE MOUNT REMOTE CONTROL (SINGLE ENGINE VERSION)

- 4** Trailer Position: Press button until drive unit reaches desired height.
- 5** Trim Up/Out: Press UP on Trim switch until drive unit reaches desired trim position.
- 6** Lower Drive Unit: Press DOWN on Trim switch until drive unit reaches desired position.

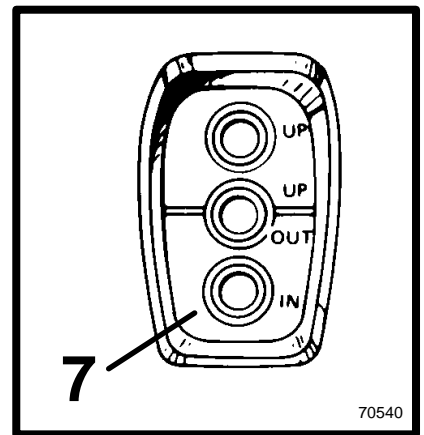
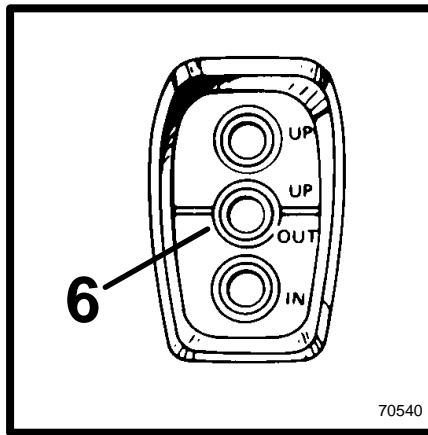
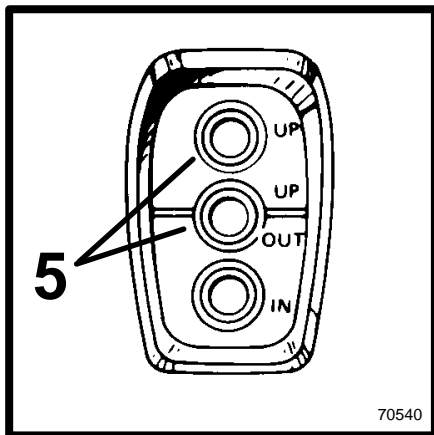
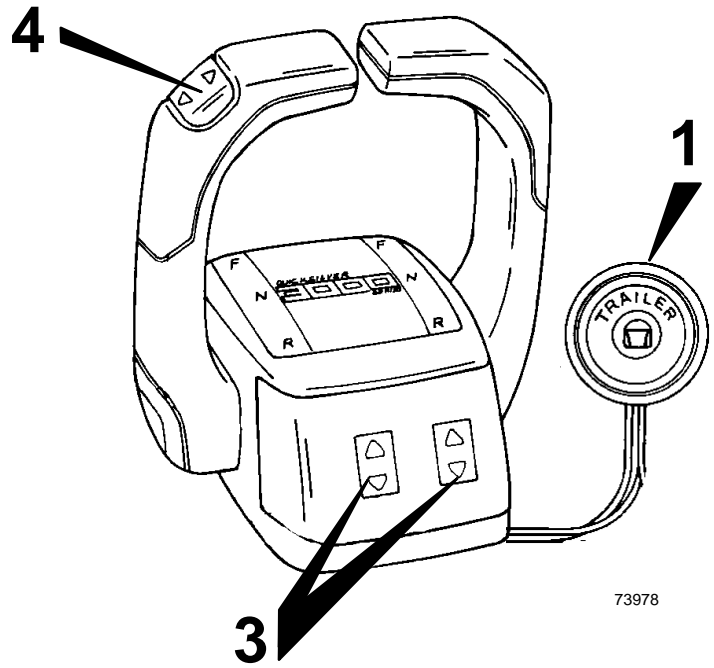
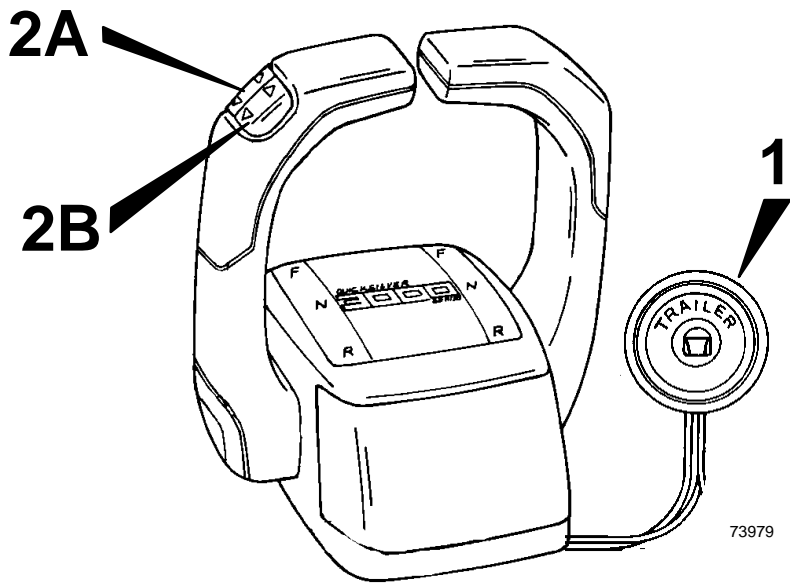

POWER TRIM OPERATION - DUAL ENGINE CONSOLE MOUNT REMOTE CONTROL (TWO BUTTON AND THREE BUTTON VERSIONS)

IMPORTANT: If TRAILER button is held depressed after drive unit reaches end of upward travel, an internal circuit breaker will open and pump will stop. Should this happen, release button and allow motor to cool for about one minute. Circuit breaker will reset and Power Trim operation may be resumed.

CAUTION

When lowering or raising stern drives equipped with a dual engine tie bar kit; in the trailering position, stern drives must be lowered evenly to prevent tie bar from becoming twisted. Failure to lower stern drives evenly may result in tie bar or stern drive(s) damage.

- 1 Trailer Button (Both Versions) - Press button until drive unit reaches desired height for trailering drive units.
- 2 **Two Button Trim Control (Dual Buttons in Handle)** - used to control both drive units from the handle. Press UP on button(s) to trim drive unit UP/OUT. Press down on button(s) to trim drive unit DOWN/IN.
 - A Forward Trim Button - Used to trim the port drive unit.
 - B Rear Trim Button - Used to trim the starboard drive unit.
- 3 **Three Button Trim Control (Trim Adjustment Switches)** - With a single integral trim button in the handle to control two engines simultaneously, these two switches control the “Fine Tune” adjustment of each engine. Using these “Fine Tune Switches”, set each engine to the desired trim angle. Then use the single trim switch in the handle to control the trim of both engines simultaneously.
- 4 **Three Button Trim Control (Single Trim Switch in Handle)** - used to trim both drives simultaneously after drives have been fine-tuned as described above.

POWER TRIM OPERATION - THREE BUTTON TRIM PANEL (USED ON MODELS WITH TWO-LEVER CONTROL)

IMPORTANT: If TRAILER button is held depressed after drive unit reaches end of upward travel, an internal circuit breaker will open and pump will stop. Should this happen, release button(s) and allow motor to cool for about one minute. Circuit breaker will reset and Power Trim operation may be resumed.

- 5 Trailer Position: Simultaneously press the UP button (top) along with the UP/OUT button (center) until drive unit reaches desired trailer position.
- 6 Trim Drive Unit UP/OUT: Press center UP/OUT button until drive unit reaches desired trim position.
- 7 Trim Drive Unit IN/DOWN: Press IN button until drive unit reaches desired trim position.

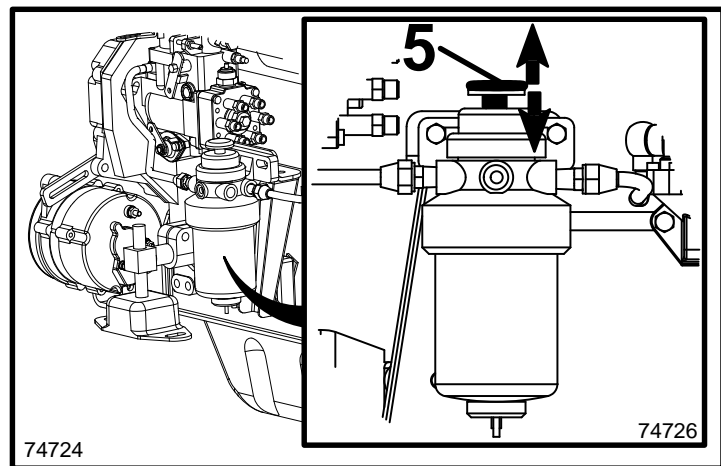
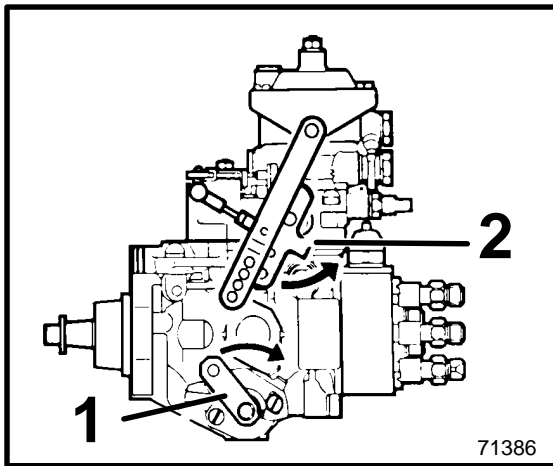

Starting, Shifting and Stopping - D3.6L/180 and D4.2L/220

NOTE: Does not include engines equipped with D-Tronic fuel injection.

⚠ WARNING

Do not use volatile starting aids, such as Ether, Propane, or Gasoline in the engine air intake system. Explosion hazard resulting from ignition of vapors by glow plugs could cause severe personal injury and engine damage.

⚠ CAUTION

It is good practice to ventilate the engine compartment prior to servicing any engine components to remove any fuel vapors which may cause difficulty breathing or be an irritant.

1 Cold Start Lever - located on the injection pump is used to aid in starting when the temperature is below 50° F (10° C). This is done by moving lever in direction shown. Lever should be reset as soon as engine starts and idles smoothly.

2 Mechanical Engine Stop Lever - located on the injection pump is used to manually shut off engine by cutting off the fuel supply. It can be engaged by moving the lever in the direction shown.

BEFORE STARTING THE ENGINE

IMPORTANT: As an added precaution, the following steps must be observed before starting:

- Do not start engine without water being supplied to seawater pickup pump (to prevent pump or engine damage).
- Never operate the starter motor longer than 15 seconds at a time, to avoid overheating the starter motor. If engine does not start, wait 1 minute to allow the starter motor to cool; then, repeat starting procedure.
- Be sure engine crankcase is filled to correct level with the proper grade of oil for the prevailing temperature. Refer to "Specifications - Crankcase Oil".
- Be sure that all electrical connections are secure.
- Check the air cleaner for proper installation of filter element.

3 Check all items listed in the MAINTENANCE SCHEDULES and OPERATION CHART - D3.6L/180 and D4.2L/220. Refer to "Table Of Contents".

4 Perform any other necessary checks, as indicated by your dealer, or specified in your boat owner's manual.

STARTING COLD ENGINE

IMPORTANT: Always check all fluid levels before starting engine. Refer to Maintenance Chart.

- 1 Turn on and run engine compartment bilge blower (if so equipped) for five minutes. Or, open engine hatch to air out bilge before attempting to start engine(s).
- 2 Set “Cold Start Lever” if temperature is below 50° F (10° C).

NOTE: Reset when engine idles smoothly.

- 3 If engine has not been run for a period of time and will not readily start with the standard starting procedure, there is a hand pump/primer knob located on the fuel filter header. Move knob up and down four or five strokes.
- 4 Pre-lubricate engine, if required. To do this, hold the “STOP” switch toggle lever DOWN while you simultaneously turn the key switch to “START” position for 15 seconds. This will rotate the starter motor and engine/oil pump. During this process the engine will not run because no fuel is injected. Allow the starter motor to cool down for one minute and repeat the above described process. To avoid overheating the starter motor, do not engage starter motor for more than 15 seconds each time. Refer to “Before Starting the Engine” as previously outlined.
- 5 Turn key switch to the “RUN” position. Observe indicator lamp for glow plugs. When cylinder temperature is great enough to sustain combustion, the indicator lamp will cease to be lighted and the engine can be started.
- 6 Turn key switch to “START” position and release when engine fires. Check to ensure charge indicator and oil pressure warning lamps go out.

⚠ CAUTION

Improper or no warm-up of engine can seriously impair the life of your diesel engine.

- 7 Run engine at Idle RPM until engine temperature is within normal operating range.

⚠ CAUTION

Never attempt to shift unit unless engine is at idle RPM. Damage to drive unit could occur.

- 8 Check to ensure all instrumentation is functioning properly and indicating normal readings.

ENGINE WARM UP

⚠ CAUTION

Improper or no warm-up of engine can seriously impair the life of your diesel engine.

- 9 After starting, check to ensure all instrumentation is functioning properly. Run engine at idle RPM until engine temperature is within normal operating range. It is very important that any engine be warmed up before applying full load. The warm-up period provides time for the lubricating oil to establish a film between moving parts.

NOTE: Engine warm-up time during cold weather can be reduced by operating vessel at reduced engine speed. Commence normal vessel operation when systems reach operating temperatures.

- 10 After the engine has reached operating temperature, oil pressure should be within range listed in the engine specifications chart. Stop the engine if oil pressure is not within this range. Locate and correct the problem, or see your Authorized MerCruiser Dealer if you are unable to determine the problem.

STARTING WARM ENGINE

- 1 Turn on and run engine compartment bilge blower for five minutes (if so equipped). Or, open engine hatch to air out bilge before attempting to start engine(s).
- 2 Turn key switch to the “RUN” position.
- 3 Turn key switch to “START” position and release when engine fires. Check to ensure charge indicator and oil pressure warning lamps go out.

⚠ CAUTION

Improper or no warm-up of engine can seriously impair the life of your diesel engine.

- 4 Check to ensure all instrumentation is functioning properly and indicating normal readings.

SHIFTING**⚠ CAUTION**

Never attempt to shift unit unless engine is at idle RPM. Damage to drive unit could occur.

- 1 To shift unit, be sure remote control/throttle lever is in NEUTRAL. Move control/shift lever with a firm, quick motion forward to shift to FORWARD gear, or backward to shift to REVERSE. After shifting drive unit, advance throttle to desired setting.
- 2 Once underway, engine oil pressure should be within the range listed in the engine specifications chart at maximum RPM, or Wide-Open-Throttle. Stop the engine if oil pressure is not within this range. Locate and correct the problem, or see your Authorized MerCruiser Dealer if you are unable to determine the problem.

IMPORTANT: Avoid stopping engine if the drive unit is in gear. If engine does stop with drive unit in gear, refer to the following procedure:

- 3 Push and pull repeatedly on remote control handle until handle returns to the neutral detent position. This may take several tries if the power package was operating above idle RPM when the engine stopped.
- 4 After handle returns to the neutral detent position, resume normal starting procedures.

ENGINE SHUT-DOWN (STOPPING)

- 5 Place remote control lever in “Neutral.”

⚠ CAUTION

Avoid damaging the turbocharger and engine. Immediate engine shutdown (stopping) after high load operation may result in permanent turbocharger bearing damage. Operate the engine at IDLE for several minutes before shut-down.

- 6 Operate the engine at idle speed for several minutes to allow the turbocharger and engine to cool.
- 7 Toggle STOP switch “Down” and hold, until engine stops completely.
- 8 Turn key switch to the “OFF” position.

Operation Chart - D3.6L/180 and D4.2L/220

STARTING PROCEDURE	AFTER STARTING	WHILE UNDERWAY	STOPPING & SHUT DOWN
Open engine hatch. Air out bilge completely.	Observe all gauges and warning lights to check condition of engine. If not normal, stop engine.	Frequently observe all gauges and indicator lights to monitor engine condition.	Shift remote control lever to neutral position.
Turn battery switch ON, if so equipped.	Check for fuel, oil, water, fluid, and exhaust leaks, etc.		Run engine at idle speed several minutes to allow the turbocharger and engine to cool.
Turn on and run engine compartment bilge blower, if so equipped, for five minutes.	Check shift and throttle control operation.		Toggle STOP switch "Down" and hold, until engine completely stops.
Check for leaks - fuel, oil, water, fluid, etc.	Check steering operation.		Turn key switch to OFF position.
Open fuel shut-off valve, if so equipped.			Turn battery switch off, if so equipped.
Open seacock, if so equipped.			Close seacock, if so equipped.
Check that mechanical engine-stop lever is <i>not</i> engaged.			Flush seawater cooling circuit, if operating in saltwater area.
Prime fuel injection system, if necessary.			
Pre-lubricate turbocharger and engine, if necessary.			
Turn key switch to "RUN" and check that lights and indicator lamps come on.			
Turn key switch to START, <i>after</i> the indicator lamp for glow plugs (if so equipped) ceases. Release key when engine starts.			
Check that charge indicator and oil pressure indicator lamps cease AFTER engine starts.			
Warm-up engine at idle RPM for several minutes.			

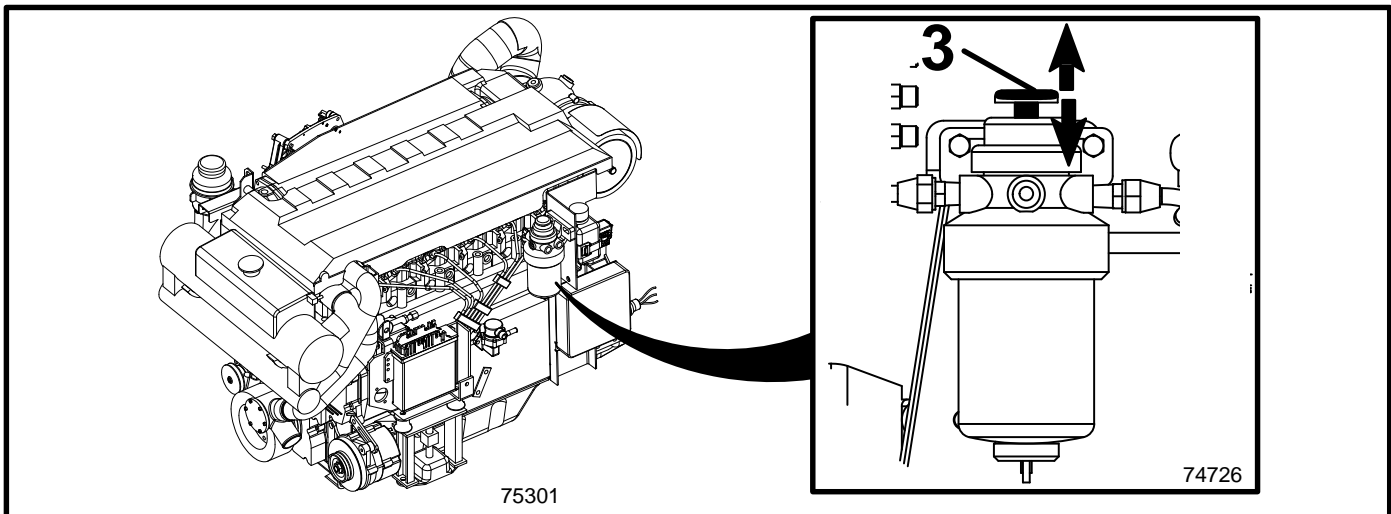

Starting, Shifting and Stopping - D2.8L D-Tronic and D4.2L D-Tronic

⚠ WARNING

Do not use volatile starting aids, such as Ether, Propane, or Gasoline in the engine air intake system. Explosion hazard resulting from ignition of vapors by glow plugs could cause severe personal injury and engine damage.

⚠ CAUTION

It is good practice to ventilate the engine compartment prior to servicing any engine components to remove any fuel vapors which may cause difficulty breathing or be an irritant.

BEFORE STARTING THE ENGINE

IMPORTANT: As an added precaution, the following steps must be observed before starting:

- Do not start engine without water being supplied to seawater pickup pump (to prevent pump or engine damage).
- Never operate the starter motor longer than 15 seconds at a time, to avoid overheating the starter motor. If engine does not start, wait 1 minute to allow the starter motor to cool; then, repeat starting procedure.
- Be sure engine crankcase is filled to correct level with the proper grade of oil for the prevailing temperature. Refer to "Specifications - Crankcase Oil".
- Be sure that all electrical connections are secure.
- Check the air cleaner for proper installation of filter element.

1 Check all items listed in the MAINTENANCE SCHEDULES and OPERATION CHART - D2.8L D-Tronic and D4.2L D-Tronic (Refer to "Table Of Contents").

2 Perform any other necessary checks, as indicated by your dealer, or specified in your boat owner's manual.

3 If engine has not been run for a period of time and will not readily start with the standard starting procedure, there is a hand pump/primer knob located on the fuel filter header. Move knob up and down four or five strokes. Attempt to start engine following normal procedure.

STARTING COLD ENGINE

IMPORTANT: Always check all fluid levels before starting engine. Refer to Maintenance Chart.

- 1 Turn on and run engine compartment bilge blower (if so equipped) for five minutes. Or, open engine hatch to air out bilge before attempting to start engine(s).
- 2 Turn key switch to the “RUN” position. Observe indicator lamp for glow plugs, if so equipped. When cylinder temperature is great enough to sustain combustion, the indicator lamp will cease to be lighted and the engine can be started.
- 3 Turn key switch to START position. Release key when engine starts and allow switch to return to RUN position.
- 4 Check to ensure all instrumentation is functioning properly and indicating normal readings. Check to ensure charge indicator and oil pressure warning lamps go out. Within seconds after starting the engine, oil pressure should exceed 10 psi (69 kPa) minimum. If the oil pressure does not meet these minimum limits, stop the engine, locate and correct the problem, or see your Authorized MerCruiser Dealer if you are unable to determine the problem.

⚠ CAUTION

Do not increase the engine speed until the oil pressure gauge indicates normal. Shut the engine down if oil pressure does not register on the gauge within 20 to 30 seconds after start.

ENGINE WARM UP**⚠ CAUTION**

Improper or no warm-up of engine can seriously impair the life of your diesel engine.

- 1 After starting, check to ensure all instrumentation is functioning properly. Run engine at idle RPM until engine temperature is within normal operating range. It is very important that any engine be warmed up before applying full load. The warm-up period provides time for the lubricating oil to establish a film between moving parts.

NOTE: *Engine warm-up time during cold weather can be reduced by operating vessel at reduced engine speed. Commence normal vessel operation when systems reach operating temperatures.*

- 2 After the engine has reached operating temperature, oil pressure should be within range listed in the engine specifications chart. Stop the engine if oil pressure is not within this range. Locate and correct the problem, or see your Authorized MerCruiser Dealer if you are unable to determine the problem.

CE32

STARTING WARM ENGINE

- 1 Turn on and run engine compartment bilge blower for five minutes (if so equipped). Or, open engine hatch to air out bilge before attempting to start engine(s).
- 2 Turn key switch to the "RUN" position. Check to ensure glow plug preheat lamp is not illuminated.
- 3 Turn key switch to the "START" position and release when engine fires. Check to ensure charge indicator and oil pressure warning lamps go out.
- 4 Check to ensure all instrumentation is functioning properly and indicating normal readings. Oil pressure should be within the range listed in the engine specifications chart. Stop the engine if oil pressure is not within this range. Locate and correct the problem, or see your Authorized MerCruiser Dealer if you are unable to determine the problem.

CE33

SHIFTING

CAUTION

Never attempt to shift unit unless engine is at idle RPM. Damage to drive unit could occur.

- 5 To shift unit, be sure remote control/throttle lever is in NEUTRAL. Move control/shift lever with a firm, quick motion forward to shift to FORWARD gear, or backward to shift to REVERSE. After shifting drive unit, advance throttle to desired setting.
- 6 Once underway, engine oil pressure should be within the range listed in the engine specifications chart at maximum RPM, or Wide-Open-Throttle. Stop the engine if oil pressure is not within this range. Locate and correct the problem, or see your Authorized MerCruiser Dealer if you are unable to determine the problem.

CB575

IMPORTANT: Avoid stopping engine if the drive unit is in gear. If engine does stop with drive unit in gear, refer to the following procedure:

- 7 Push and pull repeatedly on remote control handle until handle returns to the neutral detent position. This may take several tries if the power package was operating above idle RPM when the engine stopped.
- 8 After handle returns to the neutral detent position, resume normal starting procedures.

CD366

ENGINE SHUT-DOWN (STOPPING)

- 9 Place remote control lever in "Neutral."

CAUTION

Avoid damaging the turbocharger and engine. Immediate engine shutdown (stopping) after high load operation may result in permanent turbocharger bearing damage. Operate the engine at IDLE for several minutes before shut-down.

- 10 Operate the engine at idle speed for several minutes to allow the turbocharger and engine to cool.
- 11 Turn key switch to the "OFF" position.

Operation Chart - D2.8L D-Tronic and D4.2L D-Tronic

STARTING PROCEDURE	AFTER STARTING	WHILE UNDERWAY	STOPPING & SHUT DOWN
Open engine hatch. Air out bilge completely.	Observe all gauges and warning lights to check condition of engine. If not normal, stop engine.	Frequently observe all gauges and indicator lights to monitor engine condition.	Shift remote control lever to neutral position.
Turn battery switch ON, if so equipped.	Check for fuel, oil, water, fluid, and exhaust leaks, etc.		Run engine at idle speed several minutes to allow the turbocharger and engine to cool.
Turn on and run engine compartment bilge blower, if so equipped, for five minutes.	Check shift and throttle control operation.		Turn key switch to OFF position.
Check for leaks - fuel, oil, water, fluid, etc.	Check steering operation.		Turn battery switch, if so equipped, to OFF.
Open fuel shutoff valve, if so equipped.			Close fuel shutoff valve, if so equipped.
Open seacock, if so equipped.			Close seacock, if so equipped.
Prime fuel injection system, if necessary.			Flush seawater cooling circuit, if operating in salt-water area.
Turn key switch to "RUN" and check that lights and indicator lamps come on.			
Turn key switch to START, <i>after</i> the indicator lamp for glow plugs (if so equipped) ceases. Release key when engine starts.			
Check that charge indicator and oil pressure indicator lamps cease AFTER engine starts.			
Warm-up engine at idle RPM for several minutes.			

Maintenance

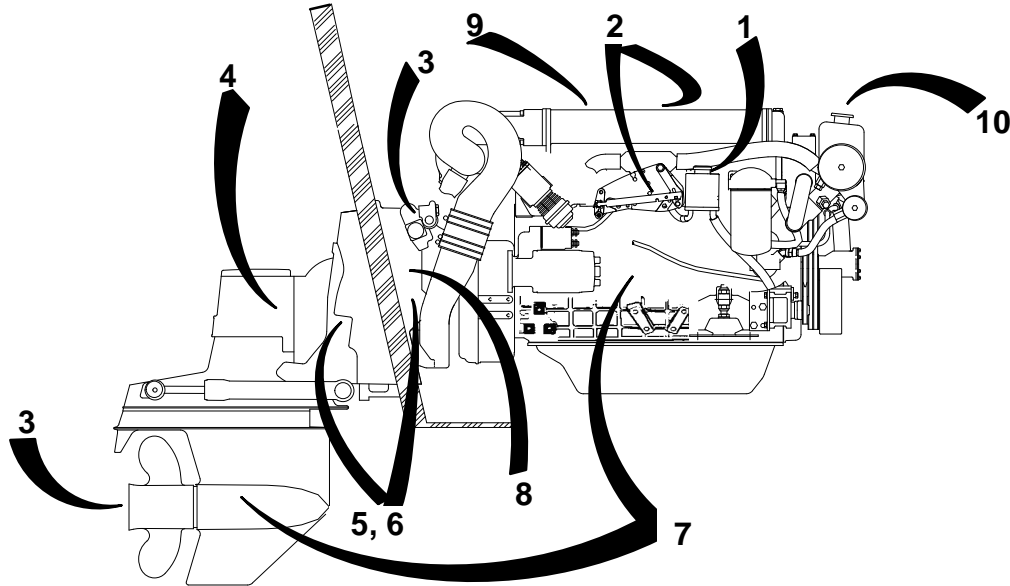

74298

Maintenance

⚠ WARNING

Always disconnect battery cables from battery **BEFORE** working around electrical system components to prevent injury to yourself or damage to electrical system should a wire be accidentally shorted.

⚠ WARNING

Always disconnect battery cables from battery **BEFORE** working on fuel system to prevent fire. This eliminates the engine wiring as a potential source of ignition.

IMPORTANT: Refer to **MAINTENANCE SCHEDULES** for complete listing of all scheduled maintenance to be performed. Some listings can be done by owner/operator, while others should be performed by an Authorized MerCruiser Dealer. Before attempting maintenance or repair procedures not covered in this manual, it is recommended that a MerCruiser Maintenance Procedures Manual or Service Manual be purchased and read thoroughly.

NOTE: Maintenance points are color coded for ease of identification. See the decal on engine for identification.

Maintenance Aids

- 1 Power Steering System - Quicksilver Power Trim and Steering Fluid, or Dexron III automatic transmission fluid (ATF).
- 2 All pivot points - SAE 30W motor oil.
- 3 Exposed Portion of Steering Cable and Propeller Shaft - Quicksilver Special Lubricant 101.
- 4 Stern Drive Unit - Quicksilver Hi-Performance Gear Lube.
- 5 Universal Joints - Quicksilver U-Joint and Gimbal Bearing Grease.
- 6 Engine Coupler and Universal Joint Shaft Splines - Quicksilver Engine Coupler Spline Grease (92-816391A4)
- 7 All Exterior Surfaces - Quicksilver Primer and Spray Paint, as needed, and Quicksilver Corrosion Guard.
- 8 Power Trim System - Quicksilver Power Trim and Steering Fluid, or SAE 10W-30 motor oil.
- 9 Crankcase Oil - API rating of CD required. (Refer to "Specifications" for list of approved oils.)
- 10 Closed Cooling System Coolant - use **ONLY** Quicksilver Premixed Marine Engine Coolant.

Maintenance Schedules

⚠ WARNING

Always disconnect battery cables from battery BEFORE working around electrical system components to prevent injury to yourself or damage to electrical system should a wire be accidentally shorted.

SCHEDULED MAINTENANCE TO BE PERFORMED BY OWNER/OPERATOR

NOTE: Only perform maintenance which applies to your particular power package.

Task	Interval	
Engine Crankcase Oil - Check level.	Before Use	
Fuel Filter - Drain		
Seawater Strainer - Check / Clean	Before Use / As Required	
Engine Crankcase Oil - Check level.	Weekly	
Closed Cooling Coolant - Check level.		
Power Steering Fluid - Check level.		
Stern Drive Unit Oil - Check level		
Battery - Check level and inspect for damage.		
Power Trim Pump Oil - Check level.		
Drive Unit Alloy Anodes - Inspect for erosion.		
Gear Housing Water Pickups - Check for marine growth or debris.		
Air Filter - Clean		Every 50 hours of operation or as conditions require.
Drive Belts (All) - Inspect condition and check tension.		Every 100 hours of operation or 120 days, whichever occurs first.
Fuel Filter - Replace.		
Propeller Shaft - Lubricate.	Saltwater Use: Every 50 hours of operation or 60 days, whichever occurs first. Freshwater Use: Every 100 hours of operation or 120 days, whichever occurs first.	
Power Package Exterior Surfaces - Spray with rust preventative.		
Sacrificial Anode (in intercooler) – Check and replace when over 50% eroded.	Once a year	
Sacrificial Anode (in heat exchanger) – Check and replace when over 50% eroded.		
Power Package Exterior Surfaces - Clean and paint.		
Cooling System - Flush seawater section.	Saltwater Use: After every use.	

Scheduled Maintenance That Should Be Performed By A Dealer

NOTE: Only perform maintenance which applies to your particular power package.

Task	Interval
Seawater Pickup Pump - Disassemble and inspect.	Whenever insufficient seawater flow is suspected, if operating temperature exceeds normal range.
Retorque cylinder heads.	After First 100 Hours of Operation or First Operating Season, Whichever Occurs First
Crankcase Oil and Filter - Change.	After 20-Hour Break-In Period, then, for Pleasurecraft Use: Every 100 Hours of Use or 120 Days, Whichever Occurs First ; and for Light Duty Use: Every 50 Hours of Use or 60 Days, Whichever Occurs First
Flame Arrestor and Crankcase Ventilation Hose - Clean and inspect.	End of first boating season and thereafter, every 100 hours of operation or once yearly, whichever occurs first.
Stern Drive Unit Oil - Change.	
Gimbal Ring Clamping Screws - Retorque to 40 lb. ft. (54 N·m).	
Rear Engine Mounts - Check, torque to 30-40 lb. ft. (47-54 N·m).	
Gimbal Bearing - Lubricate	
Cooling System - Clean and inspect.	
Engine Alignment - Check.	
Engine Coupling Universal Joint Shaft Splines - Lubricate.	
Steering System - Lubricate and inspect for loose, damage or missing parts.	
Electrical System - Check for loose or damaged wiring.	
Closed Cooling System Pressure Cap - Clean, inspect and test .	
Cooling System Hoses and Clamps - Inspect for damage and deterioration. Check clamps for tightness.	
Continuity Circuit - Check components for loose connections, broken or frayed wires.	
Shift and Throttle Cable and Linkage - Lubricate and inspect for loose, damaged or missing parts.	
Engine Exhaust System - Inspect externally for damage, deterioration and restrictions. Check for tightness.	
Steering Head and Remote Control - Inspect and lubricate.	

Scheduled Maintenance That Should Be Performed By A Dealer

NOTE: Only perform maintenance which applies to your particular power package.

Task	Interval
Fuel Filter(s) - Replace.	Once a Year
Quicksilver Mercathode System - Test output.	
Closed Cooling Coolant - Test for Alkalinity	
Heat Exchanger - Clean seawater section.	
Drive Unit Bellows and Clamps - Inspect.	
Universal Joint Cross Bearings- Inspect.	End of first boating season and thereafter, every 200 hours of operation or once yearly, whichever occurs first.
Clean Aftercooler Core.	Every 500 Hours of Operation
Clean Fuel Tank	Every 1000 Hours of Operation

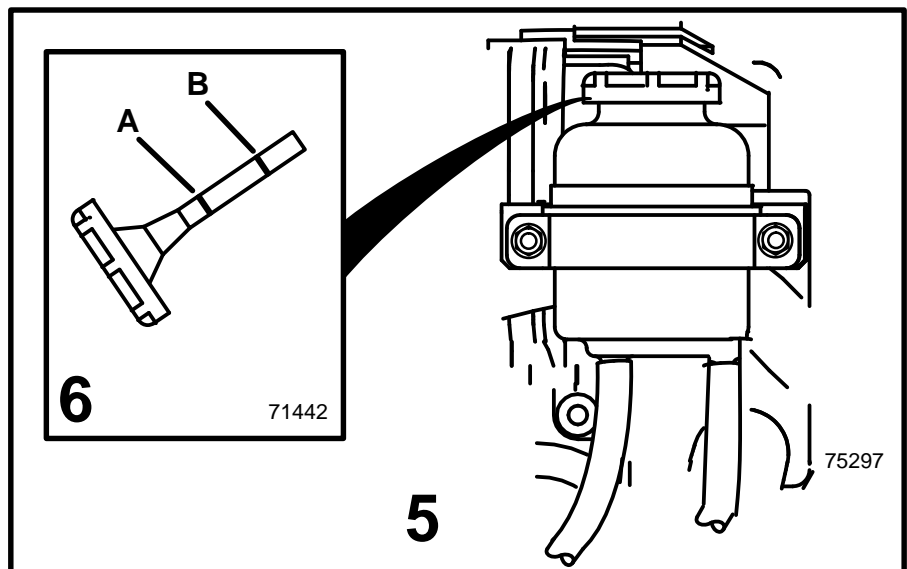
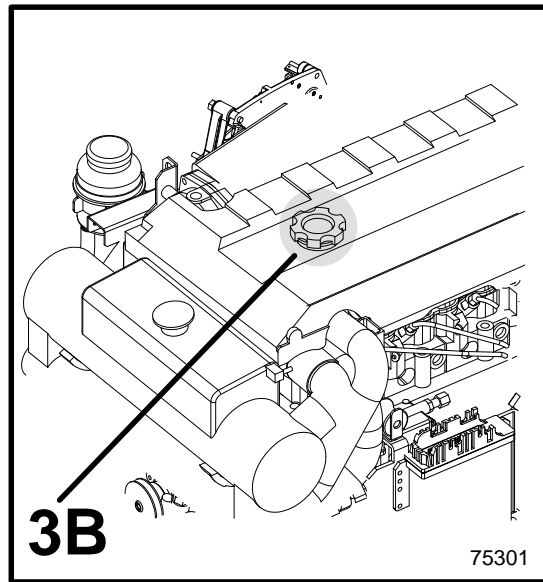
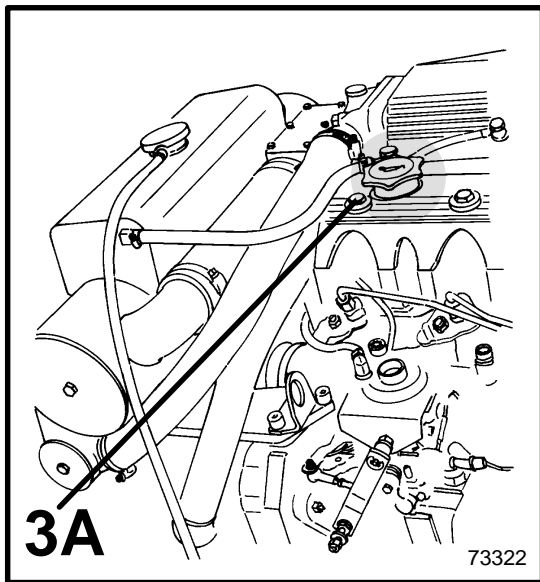
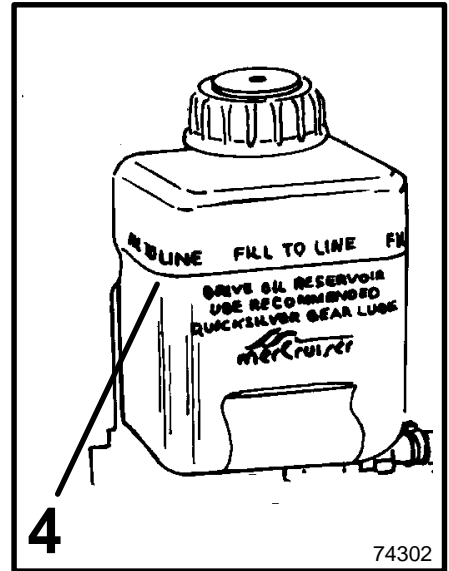
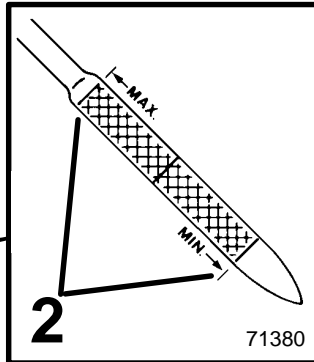
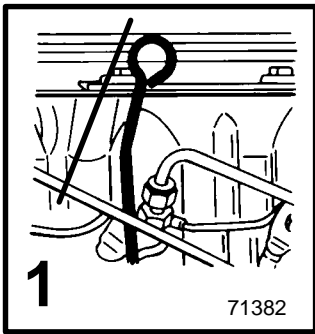

Checking Fluid Levels

CRANKCASE OIL

CAUTION

Avoid possible injury or damage to oil dipstick and internal engine components. Do not remove crankcase oil dipstick when engine is running. Stop the engine completely before removing or inserting dipstick.

Check engine oil daily before first start-up.

If it becomes necessary to check oil level during operation, **stop engine** and allow 5 minutes for oil to drain into pan.

- 1 Remove dipstick. Wipe clean and reinstall into dipstick tube.
- 2 Remove dipstick and observe oil level. Oil must be between MIN and MAX marks on dipstick. If necessary, add oil as follows.
- 3 Remove oil filler cap. Add specified oil to bring level up to, but not over, "MAX" mark on dipstick. Reinstall oil filler cap.

A D3.6L/180 and D4.2L/220

B D2.8L D-Tronic and D4.2L D-Tronic

DRIVE UNIT OIL

4 Check gear lube monitor oil level; keep oil level at or near "Fill" line. Check for water at bottom of monitor, and/or if oil appears a milky-tan, contact your Authorized MerCruiser Dealer immediately; both conditions indicate a water leak somewhere in the drive unit.

IMPORTANT: If more than 2 fl. oz.. (59ml) of Quicksilver Gear Lube are required to fill drive unit, a seal may be leaking. Contact your Authorized MerCruiser Dealer for service. Damage to unit may occur due to lack of lubrication.

POWER STEERING PUMP FLUID

IMPORTANT: If fluid is not visible in reservoir, contact your Authorized MerCruiser Dealer.

Power steering fluid must be checked with engine off and drive unit pointed straight back. Check with engine warm.

- 5 Remove fill cap/dipstick from reservoir. Wipe clean and reinstall into reservoir.
- 6 Remove fill cap/dipstick from reservoir and observe fluid level. Fluid must be between marks A and B on fill cap/dipstick.
 - A** MAXIMUM - "FULL HOT" Fluid Level -top Line. Fill to this level when fluid is hot. *Do not overfill.*
 - B** MINIMUM - "FULL COLD" Fluid Level - Fill to this level when fluid is cold. Do not allow fluid to drop below this level.
- 7 If necessary, add Quicksilver Power Trim and Steering Fluid or, if Quicksilver Power Trim and Steering Fluid is not available, use Dexron III, to bring fluid to proper level. Replace fill cap/dipstick.

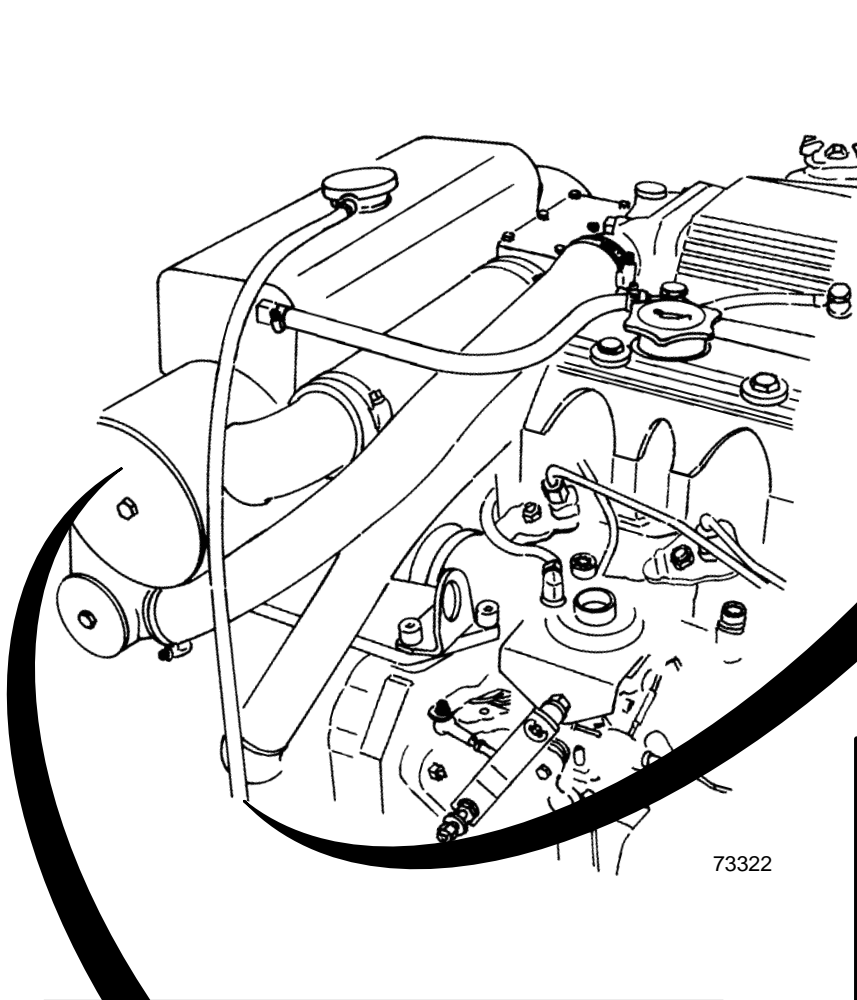

73322

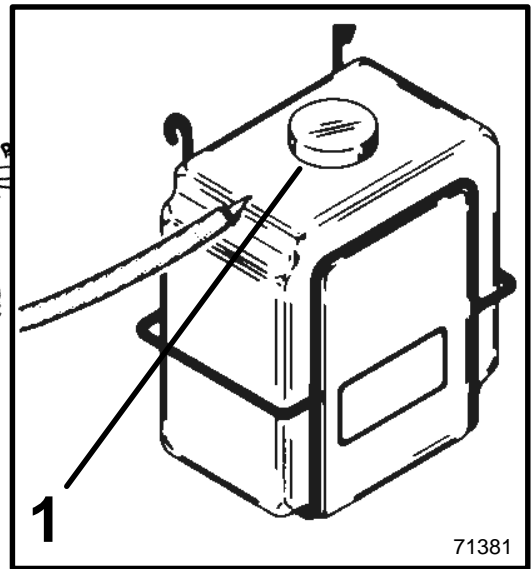

71381

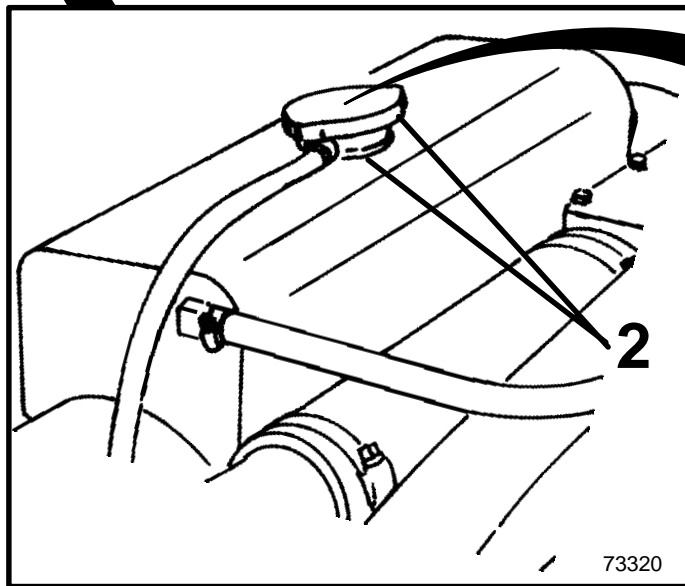

73320

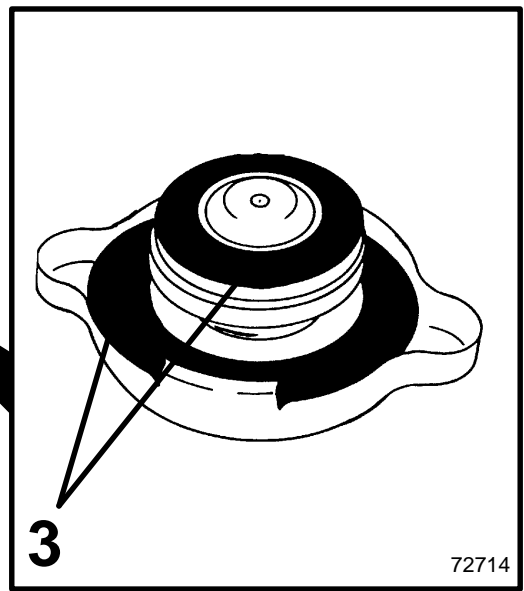

72714

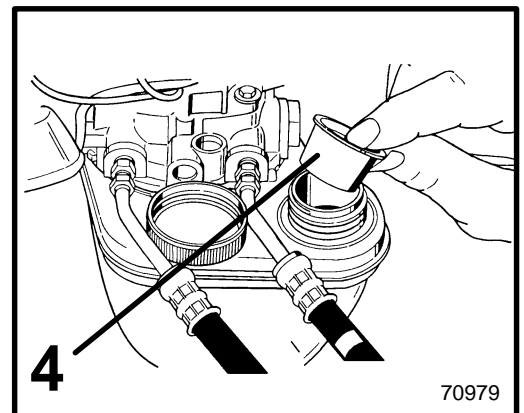

70979

ENGINE COOLANT

1 Before starting engine, check coolant level in coolant recovery bottle. Coolant level must be between the “ADD” and “FULL” marks (on front of bottle). If level is low, remove fill cap from coolant recovery bottle and add specified coolant as required. Refer to “Specifications” for proper coolant.

⚠ WARNING

Do not remove coolant tank cap when engine is hot. Coolant may discharge violently, causing severe burns.

2 If coolant level *in coolant recovery bottle* was low:

- Inspect coolant recovery system for leaks.
- Inspect coolant tank cap gaskets for damage and replace if necessary.
- Also, the tank cap maintains pressure on the coolant tank. It may not be holding pressure properly. To have cap tested, contact your Authorized MerCruiser Dealer.

⚠ CAUTION

If the coolant should get extremely low and the engine very hot, let the engine cool for approximately 15 minutes before adding coolant; then, with the engine running, add coolant slowly. Adding cold coolant to a hot engine may crack the cylinder head or crankcase. Never use water alone.

3 Periodically, to ensure that coolant recovery system is functioning properly, you should allow engine to cool and then *slowly and carefully* remove coolant tank cap. Coolant level must be to the bottom edge of the tank filler neck. If coolant is low, add specified coolant as necessary to bring up to proper level. Refer to items **1** and **2** above.

POWER TRIM PUMP FLUID

Power trim pump fluid level must be checked with the drive unit in the full “Down/In” position.

IMPORTANT: Trim pump reservoir fill cap has a small vent hole in it. Occasionally check to ensure vent is not restricted.

Power trim pump fluid level must be checked with the drive unit in the full “Down/In” position.

4 New trim pumps have a shipping “cap plug” in the reservoir fill neck. Check to ensure that this “cap plug” is NOT present in filler neck. **Remove** and **discard** “cap plug” if present. Remove cap and observe oil level. Level must be up to, but not over, the bottom edge of fill neck. Add Quicksilver Power Trim and Steering Fluid as necessary to bring oil to proper level, if available, or use SAE 10W-30 or 10W-40 motor oil. Replace reservoir cap.

IMPORTANT: Fill cap has a small hole in it which acts as a vent. Frequently check that vent is open and unrestricted.

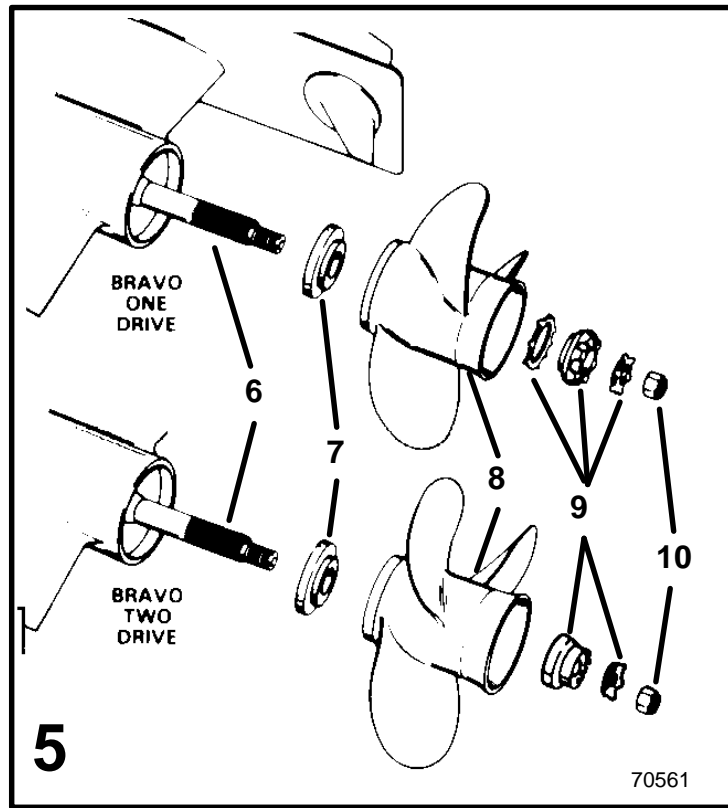
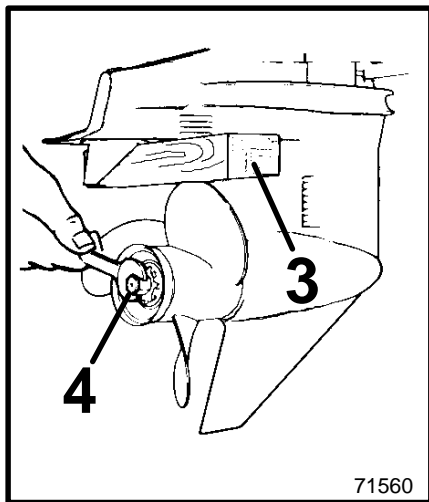
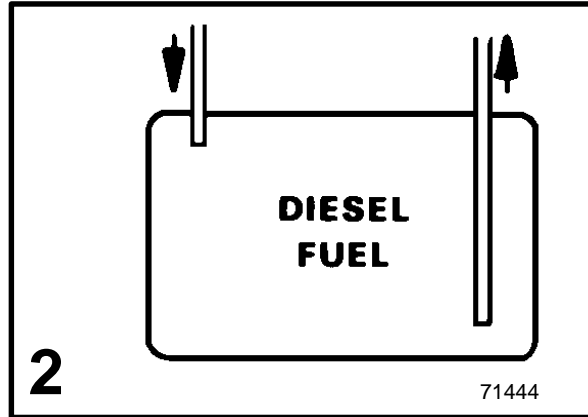
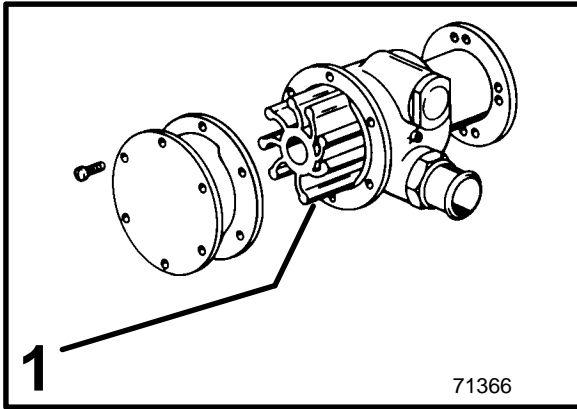

CB66

Seawater Pump Impeller

This maintenance should be performed by an Authorized MerCruiser Dealer.

- 1 Seawater pump impeller should be inspected whenever insufficient seawater flow is suspected (if operating temperature exceeds normal range).

CE56

Flushing Fuel Tank

- 2 Flush and clean diesel fuel tank (every 1000 hours, maximum) following boat manufacturer's instructions.

CA421

Propellers (Bravo One and Two)

WARNING

Avoid Injury: Remote Control must be in NEUTRAL and ignition key removed from switch before removing and/or installing propeller.

WARNING

Avoid Injury: Place a block of wood between anti-ventilation plate and propeller to protect hands from propeller blades and to prevent propeller from rotating when removing propeller nut.

CAUTION

Avoid Injury: Periodically check propeller nut for tightness during boating season. A minimum of 55 lbs. ft. (75 N·m) torque is required.

CA78

REMOVAL (BRAVO ONE AND TWO)

- 3 Place wood block between propeller blade and anti-ventilation plate to prevent rotation. Straighten bent tabs on tab washer.
- 4 Turn propeller shaft nut counterclockwise to remove nut.
- 5 Slide tab washer, spline washer, propeller and thrust hub off propeller shaft.

CA79

REPAIR

Some damaged propellers can be repaired. See your dealer.

CB339

INSTALLATION (BRAVO ONE AND TWO)

IMPORTANT: If reusing tab washer, carefully inspect tabs for cracks or other damage. Replace tab washer if condition is questionable.

- 6 Apply a liberal coat of one of the following Quicksilver lubricants to propeller shaft: Anti-Corrosion Grease, Special Lubricant 101, or 2-4-C Marine Lubricant with Teflon.
- 7 Slide thrust hub into propeller hub, with stepped side toward propeller hub.
- 8 Align splines and place propeller and thrust hub on propeller shaft.
- 9 Place continuity washer, spline washer and tab washer onto shaft.
- 10 Install propeller nut. Tighten nut securely. A minimum of 55 lbs. ft. (75 N·m) torque is required. Bend three tabs on tab washer down into grooves in spline washer. After first use, bend the three tabs straight, retighten propeller nut to minimum 55 lbs. ft. torque (75 N·m). Bend tabs back down into spline washer. Check propeller at least after 20 hours of operation. Do not operate with loose propeller.

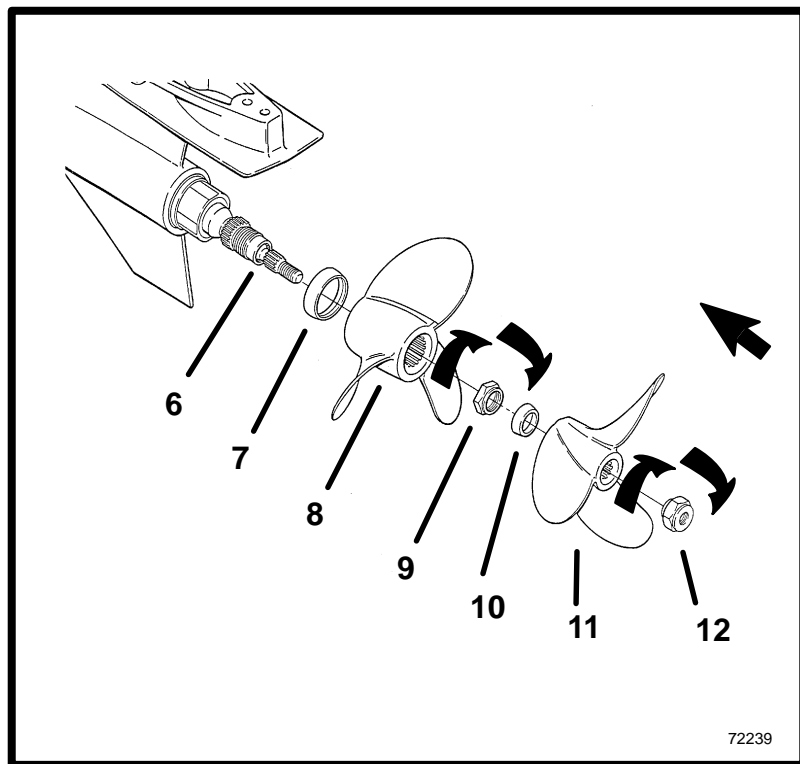
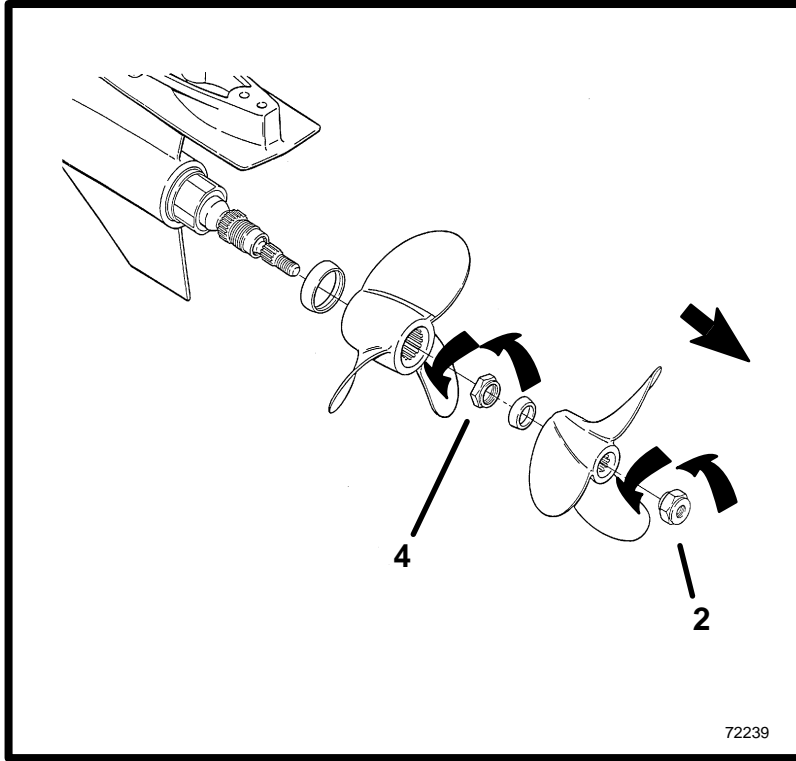

Propellers (Bravo Three)

WARNING

Avoid Injury: Remote Control must be in NEUTRAL and ignition key removed from switch before removing and/or installing propellers.

WARNING

Avoid Injury: Place a block of wood between splash-plate and propellers to protect hands from propeller blades and to prevent propellers from rotating when removing propeller nuts.

CAUTION

Avoid Injury: Do not operate with loose propeller. Periodically check propeller nuts for tightness during boating season.

REMOVAL (BRAVO THREE)

- 1 Place wood block between propeller blades and anti-ventilation plate to prevent rotation.
- 2 Turn aft propeller shaft nut counterclockwise to remove nut.
- 3 Slide propeller and thrust hub off propeller shaft.
- 4 Turn front propeller shaft nut counterclockwise to remove nut.
- 5 Slide propeller and thrust hub off propeller shaft.

CA79

REPAIR

Some damaged propellers can be repaired. See your dealer.

CB345

INSTALLATION (BRAVO THREE)

- 6 Apply a liberal coat of one of the following Quicksilver lubricants to both propeller shafts: Special Lubricant 101, 2-4-C Marine Lubricant with Teflon, or Anti-Corrosion Grease.
- 7 Slide forward thrust hub onto propeller shaft, with tapered side toward propeller hub (toward end of shaft).
- 8 Align splines and place propeller on propeller shaft.
- 9 Install propeller nut. Tighten nut securely. A minimum of 100 lbs. ft. (136 N·m) torque is required. Check propeller at least after 20 hours of operation. Do not operate with loose propeller.
- 10 Slide aft thrust hub onto propeller shaft, with tapered side toward propeller hub (toward end of shaft).
- 11 Align splines and place propeller on propeller shaft.
- 12 Install propeller nut. Tighten nut securely. A minimum of 60 lbs. ft. (81 N·m) torque is required. Check propeller at least after 20 hours of operation. Do not operate with loose propeller.

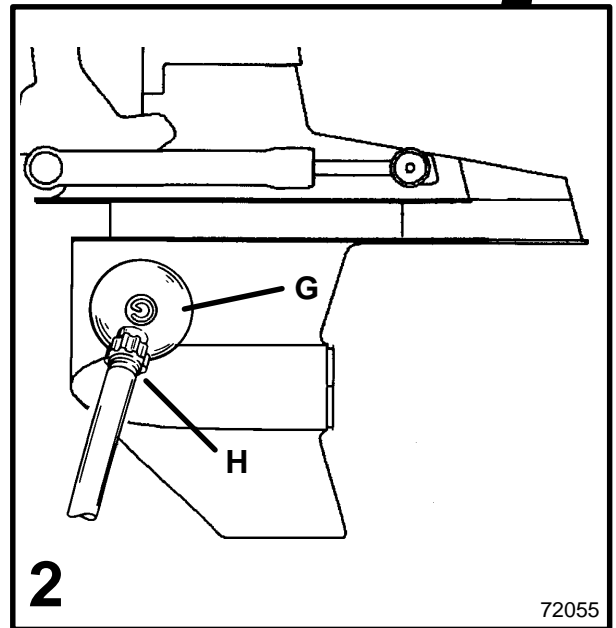
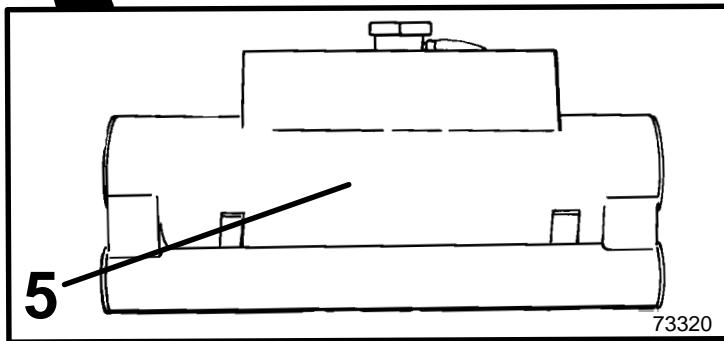
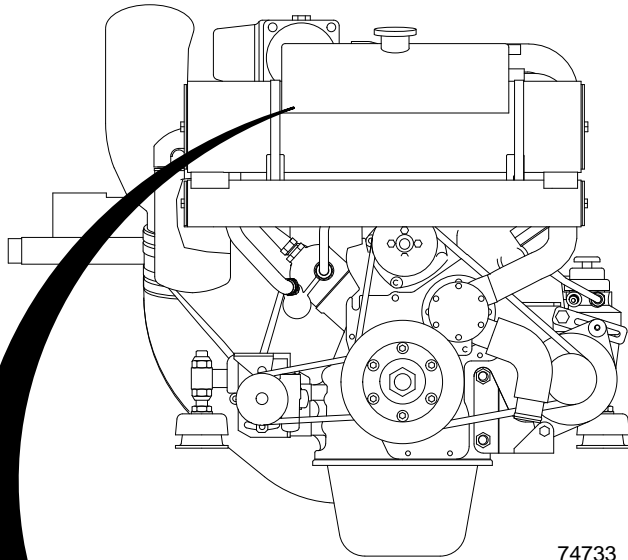
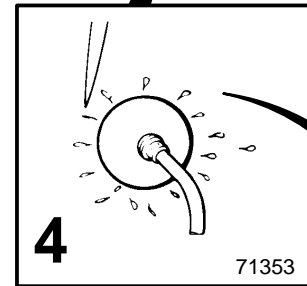
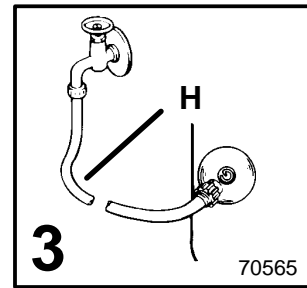
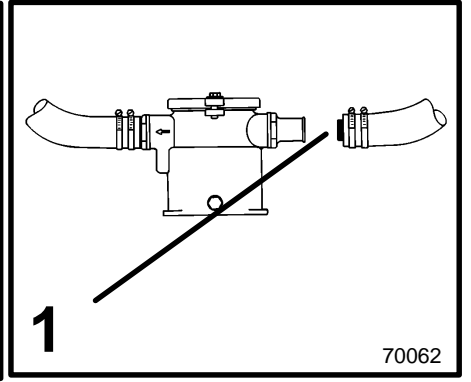
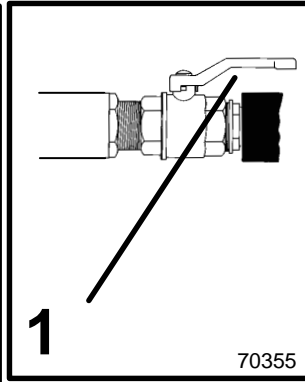
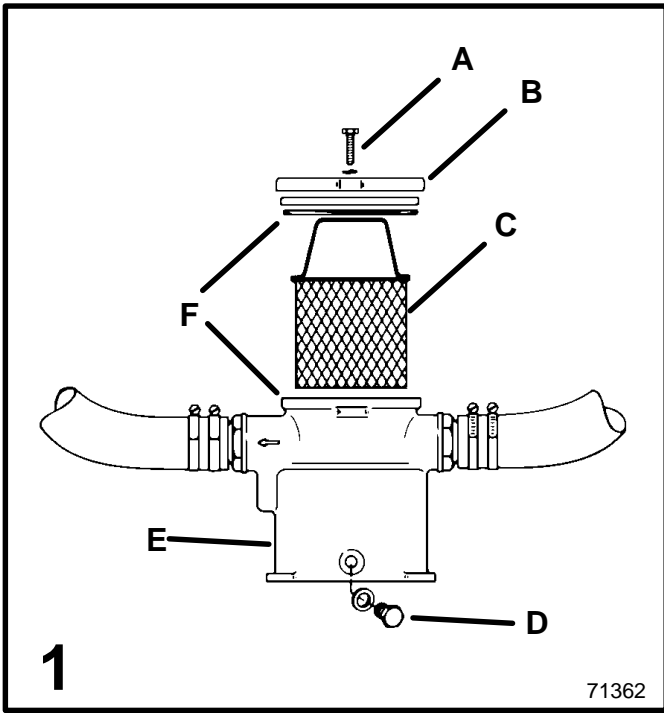

Cleaning Quicksilver Seawater Strainer

NOTE: Refer to manufacturers instructions if equipped with other than a Quicksilver seawater strainer.

⚠ CAUTION

When cleaning seawater strainer, close seacock, if so equipped. If boat is not equipped with a seacock, remove and plug seawater inlet hose to prevent a siphoning action that may occur, allowing seawater to flow from the drain holes or removed hoses.

1 With engine off, close seacock if so equipped, or remove and plug seawater inlet hose. Remove 2 screws and washers (A), and cover (B). Remove strainer (C), and drain plug and washer (D), and clean any debris from strainer housing; flush both strainer and housing (E) with clean water. Check gasket (F) - replace when necessary (if it leaks). Reinstall drain plug and washer. Reattach cover with screws and washers. Prior to starting engine, open seacock if so equipped, or remove plug from seawater inlet hose and reconnect. Tighten hose clamps securely. After starting engine, check for leaks, and/or air in system (which would indicate an external leak).

Flushing Seawater Cooling System

To prevent silt and/or salt buildup in the seawater circuit of cooling system, flush with tap water at specified Intervals.

⚠ WARNING

When flushing, be certain the area around propeller is clear, and no one is standing nearby. To avoid possible injury, remove propeller.

⚠ CAUTION

Do not run engine above 1500 RPM when flushing. Suction created by seawater pickup pump may collapse flushing hose, causing engine to overheat.

⚠ CAUTION

Watch temperature gauge on dash to ensure that engine does not overheat.

2 Install Quicksilver flushing attachment (G) (or equivalent) over water intake openings in gear housing.

NOTE: If flushing cooling system with boat in water, raise drive unit to TRAILER position, install flushing attachment and lower drive unit to full down/in position.

3 Connect hose (H) between flushing attachment and water tap.

4 With drive unit in normal operating position, partially open water tap (about 1/2 maximum). Place remote control in NEUTRAL, idle speed position and start engine. Operate engine at idle speed, in NEUTRAL, for about 10 minutes, or until discharge water is clear. Stop engine, shut off water and remove flushing attachment.

5 The closed section of cooling system that contains coolant does not need to be flushed. Coolant is changed at specified intervals. Refer to "Maintenance Schedule."

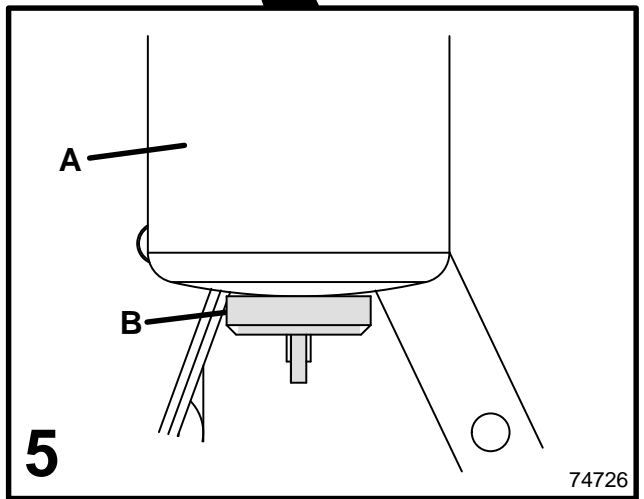
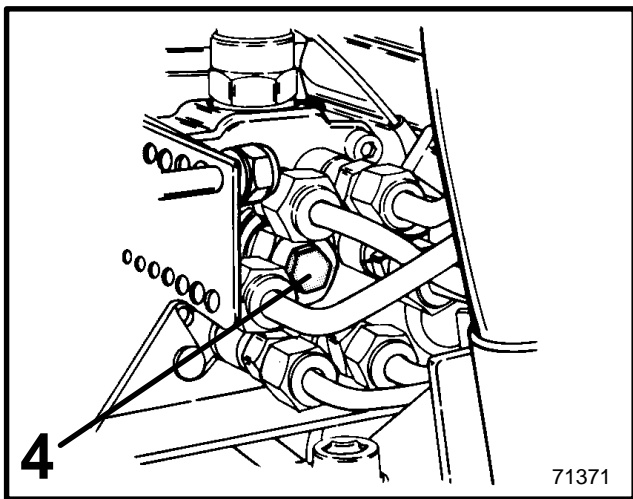
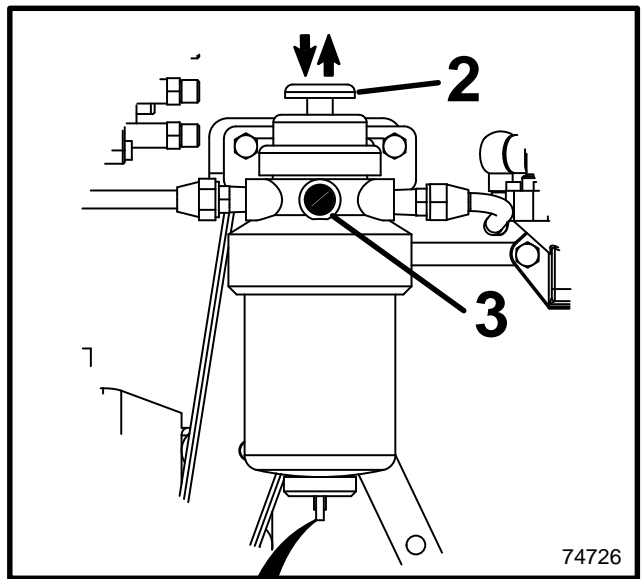
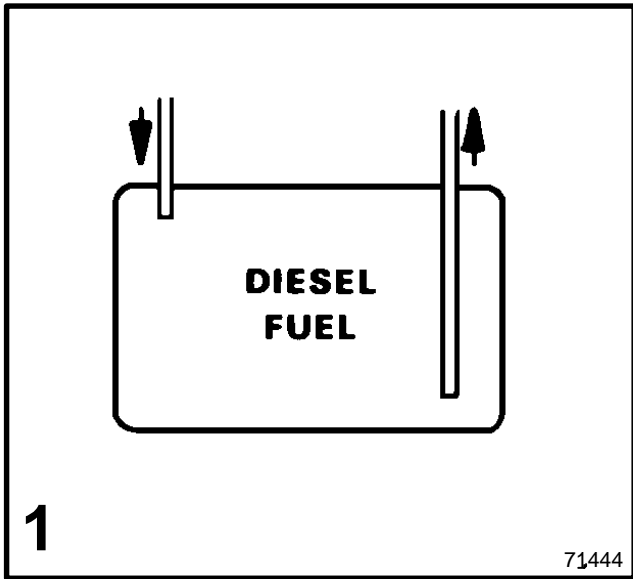

Fuel System

⚠ CAUTION

Absolute cleanliness is required for work on the fuel system, since the injection pump and fuel injectors have very close tolerances. Even minute particles of dirt or small amounts of water can impair the function of the fuel injection system.

FUEL TANK

IMPORTANT: Diesel fuel should not be left in tank during winter storage, as an accumulation of rust, sludge and wax residue will form.

- 1 Fuel tank should be cleaned at specified intervals. Refer to boat manufacturer's instructions.

CD283

HAND PUMP/PRIMER

2 A plunger-type of hand pump/primer is located on the fuel filter bracket and is used to: (1) refill fuel system if system was run dry; (2) refill fuel filter when changing filter; or (3) to prime the fuel system if engine has not been run for a while.

To operate the hand pump/primer, move the plunger (upper portion) up and down as needed.

CE63

PRIMING FUEL SYSTEM

Prime engine if it has not been run for a while or if engine will not start. Move the hand pump/primer plunger up and down several times as previously outlined. Attempt to start engine.

CD284

FILLING FUEL FILTER

NOTE: Follow this procedure after installing new filter or if fuel has been drained from filter checking for water.

3 Loosen bleed screw on fuel filter bracket. As previously outlined, move plunger on hand pump/primer up and down repeatedly, until an air free stream of fuel flows from bleed screw. Filter is full when this occurs. Tighten bleed screw.

CD285

FILLING (BLEEDING) FUEL SYSTEM

NOTE: Follow this procedure if fuel system was run dry or if part of fuel system was drained for a service function.

Fill fuel system up to the point that fuel filter is full following previous procedure (Filling Fuel Filter); then, ensure that bleed screw on fuel filter bracket is closed.

4 Loosen, DO NOT REMOVE, bleed screw on fuel injection pump (located between fuel line connection fittings on injection pump). Continue to repeatedly move plunger on hand pump/primer, until an air-free stream of fuel flows from injection pump bleed screw. Tighten bleed screw.

CD286

DRAINING WATER SEPARATING FUEL FILTER

⚠ WARNING

Be careful when draining water separating fuel filter. Diesel fuel is flammable. Be sure ignition key is OFF. Do not allow fuel to contact any hot surfaces which may cause it to ignite. Do not allow sources of open flame in the area. Wipe up any spilled fuel immediately. Dispose of fuel soaked rags, paper, etc. in an appropriate air tight, fire retardant container. Fuel soaked items may spontaneously ignite and result in a fire hazard which could cause serious bodily injury or death.

5 The filter (A) can be drained of water and small dirt particles by opening drain cock at bottom of filter. Open by turning the drain (B) counterclockwise (*as viewed from the bottom of the filter*). Drain until fuel is clear in appearance. Close drain by turning clockwise. Tighten securely. Fill fuel filter as previously outlined.

NOTE: To ensure complete draining, in warm weather open the water bleed valve before starting daily operations. In cold weather, where there is a possibility that the condensed water will freeze, drain the filter shortly after the end of daily operations.

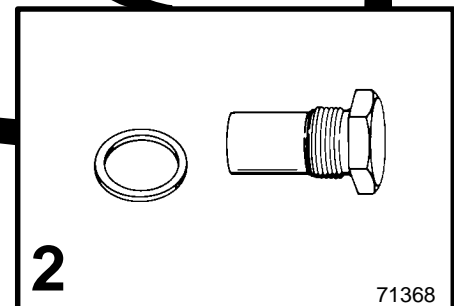
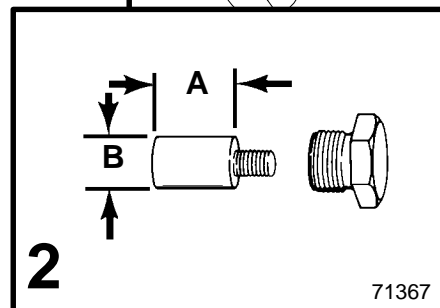
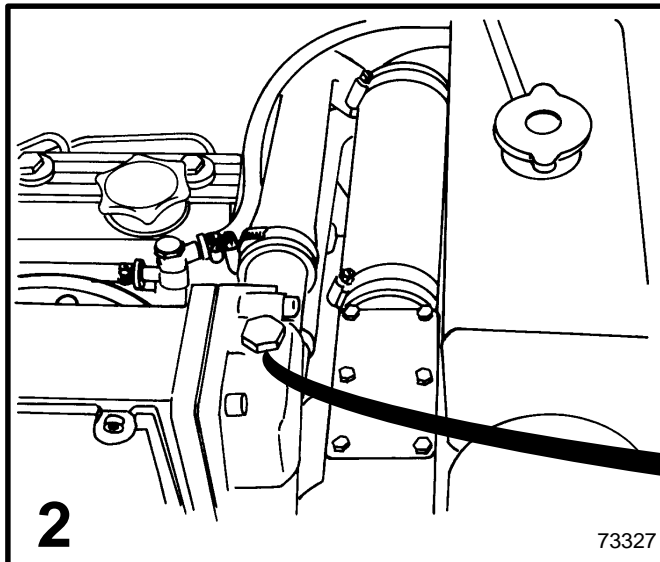
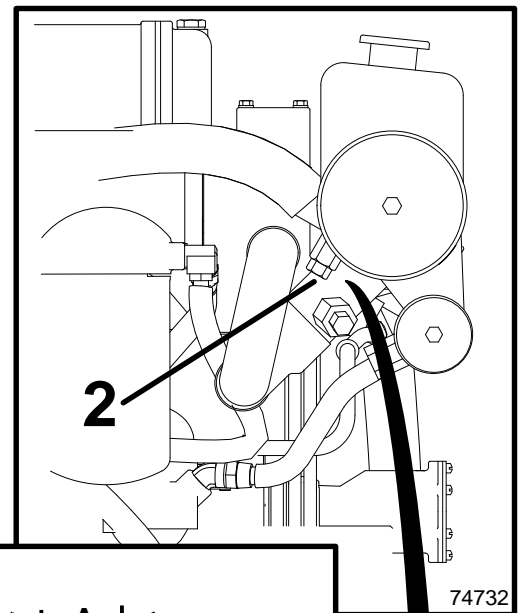
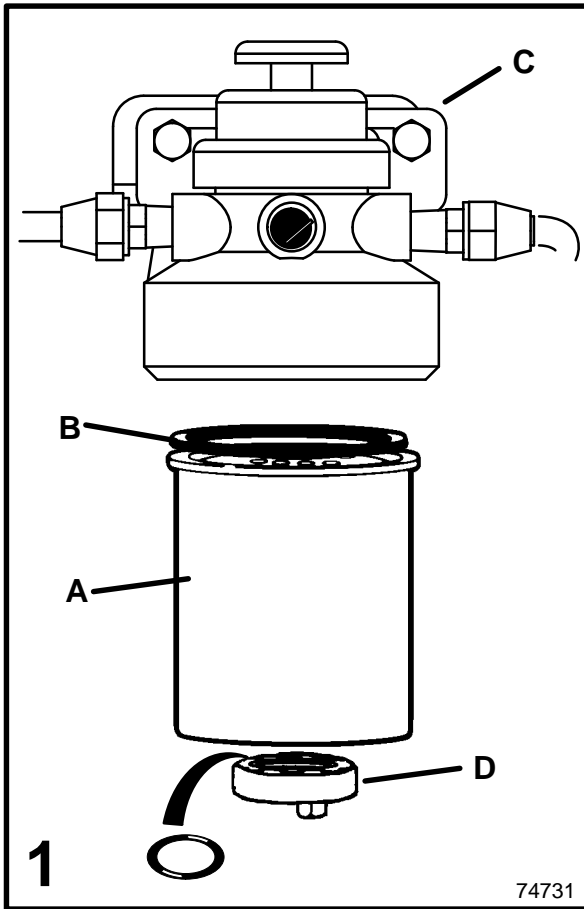

REPLACING WATER SEPARATING FUEL FILTER**⚠ CAUTION**

Any water entering the fuel injection system will disable the system. Check for water in water separating fuel filter before startup, daily.

⚠ CAUTION

If water should enter the fuel injection system, take unit to an Authorized MerCruiser Dealer IMMEDIATELY, so that corrosion and rusting of the injectors and other components can be avoided.

⚠ WARNING

Be careful when changing water separating fuel filter. Diesel fuel is flammable. Be sure ignition key is OFF. Do not allow fuel to contact any hot surfaces which may cause it to ignite. Do not allow sources of open flame in the area. Wipe up any spilled fuel immediately. Dispose of fuel soaked rags, paper, etc. in an appropriate air tight, fire retardant container. Fuel soaked items may spontaneously ignite and result in a fire hazard which could cause serious bodily injury or death.

1 Replace as follows:

- Remove, and discard, water separating fuel filter (A) and sealing ring (B) from mounting bracket (C).
- Coat sealing ring on new filter with clean motor oil.
- Thread filter onto bracket and tighten securely by hand. Do not use a filter wrench.
- Remove the drain cap and O-ring from bottom of the filter. Install on new filter. Check that bottom drain cap (D) is securely tightened. Fill fuel filter as explained previously. Check drain cap for fuel leaks.

⚠ WARNING

Make sure no leaks exist before closing engine hatch.

- Start and run engine. Check filter connection for fuel leaks. If leaks exist, recheck filter installation. If leaks continue, stop engine immediately and contact your Authorized MerCruiser Dealer.

Corrosion And Corrosion Protection**INTERNAL COMPONENTS**

2 There are anodes as part of the intercooler and heat exchanger systems, which serves as a sacrificial anodes.

Replace when eroded more than 50%; check at least once yearly.

A Length When New - 3/4 in. (19mm)

B Diameter When New - 5/8 in. (15mm)

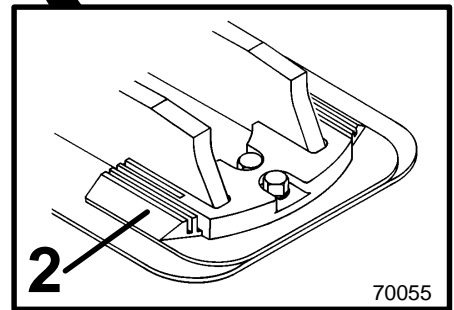
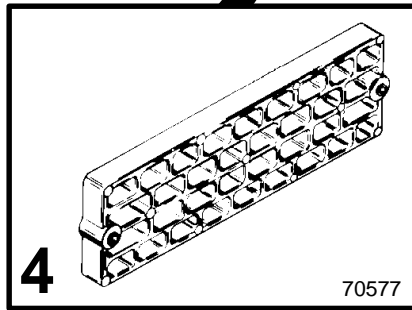
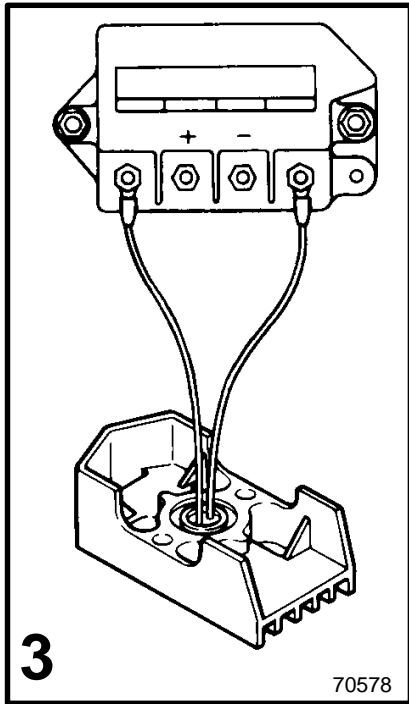
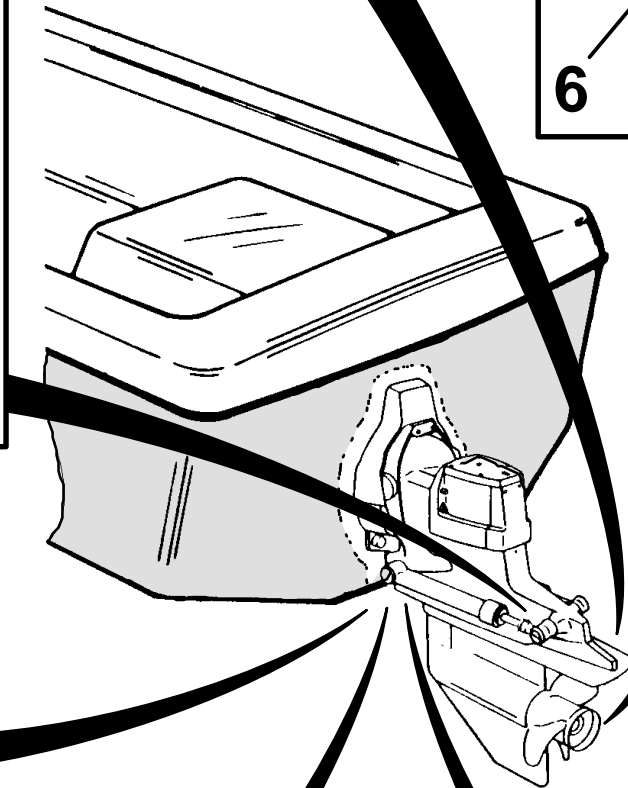
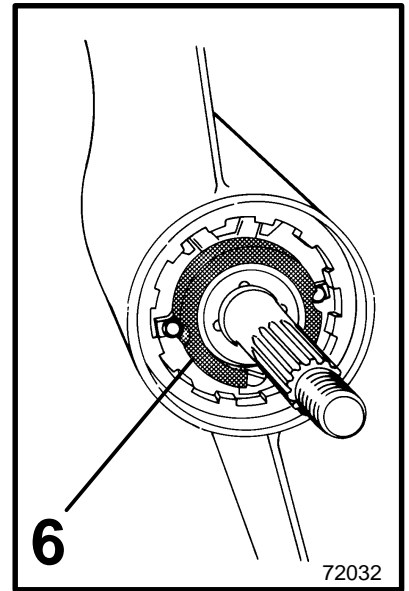
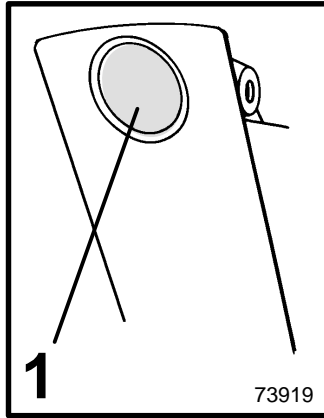
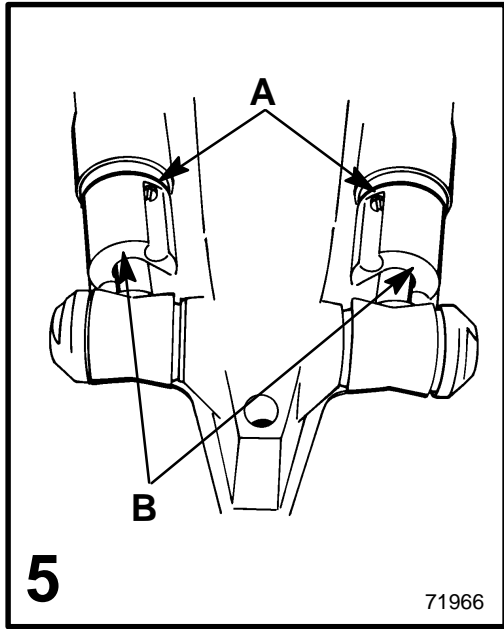

EXTERNAL COMPONENTS

Whenever two or more dissimilar metals (like those found on the stern drive) are submerged in a conductive solution, such as saltwater, polluted water, or water with a high mineral content, a chemical reaction takes place causing electrical current to flow between metals. The electrical current flow causes the metal that is most chemically active, or anodic, to erode. This is known as galvanic corrosion and, if not controlled, it will in time cause the need for replacement of power package components exposed to water.

IMPORTANT: Replace sacrificial anodes if eroded 50% or more.

1 Universal Anodic Plate - serves as a sacrificial anode.

Remove plug from drive shaft housing to access attaching screw and insert 1/2 inch socket. Unthread attaching screw and remove universal anodic plate. **Do not remove screw.** Install new anodic plate and tighten screw securely. Install plug.

2 Anodic Plate - serves as a sacrificial anode. Unscrew both attaching screws and remove. Install a new anodic plate and tighten securely.

3 MerCathode System - should be tested to ensure adequate output.

Test should be made where boat is moored, using Quicksilver Reference Electrode and Test Meter. Contact your Authorized MerCruiser Dealer to arrange for this test.

4 Anode Kit (if so equipped) - Mounted to boat transom. Acts as a sacrificial anode. Replace as required.

CA163

5 Trim Cylinder Anodes - are mounted on each trim cylinder. To replace the trim cylinder anodes:

A Remove two screws from each anode.

B Install new anodes and tighten securely.

CD359

6 Propeller Anode (Bravo One) - is located in front of the propeller, between the front side of the propeller and the gear housing. Refer to "Propeller" section in this manual for propeller removal and installation. To replace the propeller anode:

A Remove propeller.

B Remove two screws from anode.

C Install new anode and tighten securely.

D Reinstall propeller.

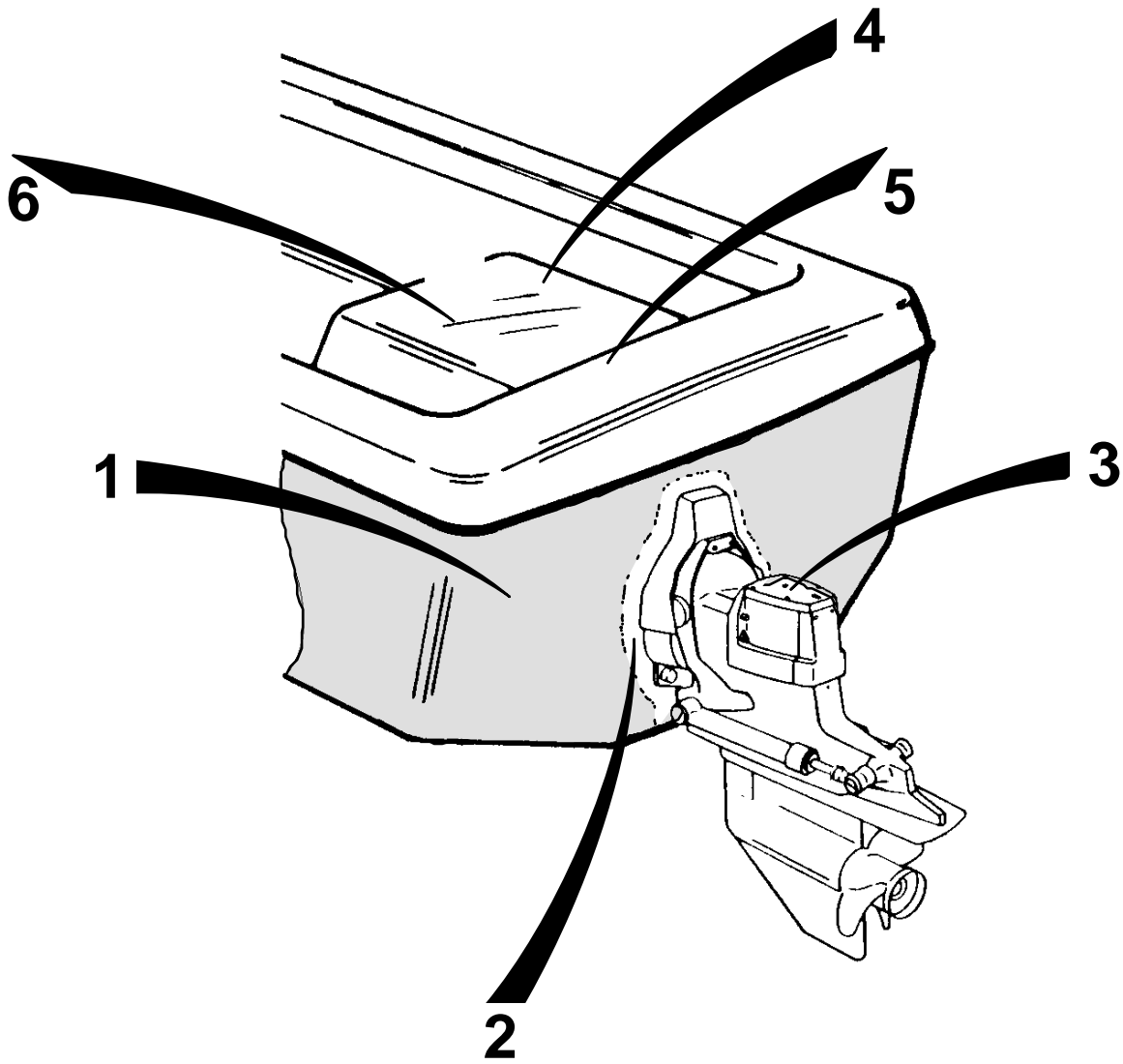

71176

In addition to the corrosion protection devices, the following steps should be taken to inhibit corrosion:

IMPORTANT: Corrosion damage that results from the improper application of anti-fouling paint will not be covered by the limited warranty.

1 Painting Boat Hull or Boat Transom: Antifouling paint may be applied to boat hull and boat transom but you must observe the following precautions:

IMPORTANT: DO NOT paint anodes or MerCathode System reference electrode and anode, as this will render them ineffective as galvanic corrosion inhibitors.

IMPORTANT: If anti-fouling protection is required for boat hull or boat transom, copper or tin base paints, if not prohibited by law, can be used. If using copper or tin based anti-fouling paints, observe the following:

2 Avoid any electrical interconnection between the MerCruiser Product, Anodic Blocks, or MerCathode System and the paint by allowing a minimum of 1-1/2 in. (40mm) UNPAINTED area on transom of the boat around these items.

3 Painting Drive Unit or Transom Assembly: Drive unit and transom assembly should be painted with a good quality marine paint or an anti-fouling paint that DOES NOT contain copper, tin, or any other material that could conduct electrical current. Do not paint drain holes, anodes, MerCathode system, and items specified by boat manufacturer.

4 Spray power package components on inside of boat every 2-3 weeks with Quicksilver Corrosion Guard to protect finish from dulling and corrosion. External power package components may also be sprayed.

5 All lubrication points, especially steering system, shift and throttle linkages, should be kept well lubricated.

6 Flush cooling system periodically, preferably after each use.

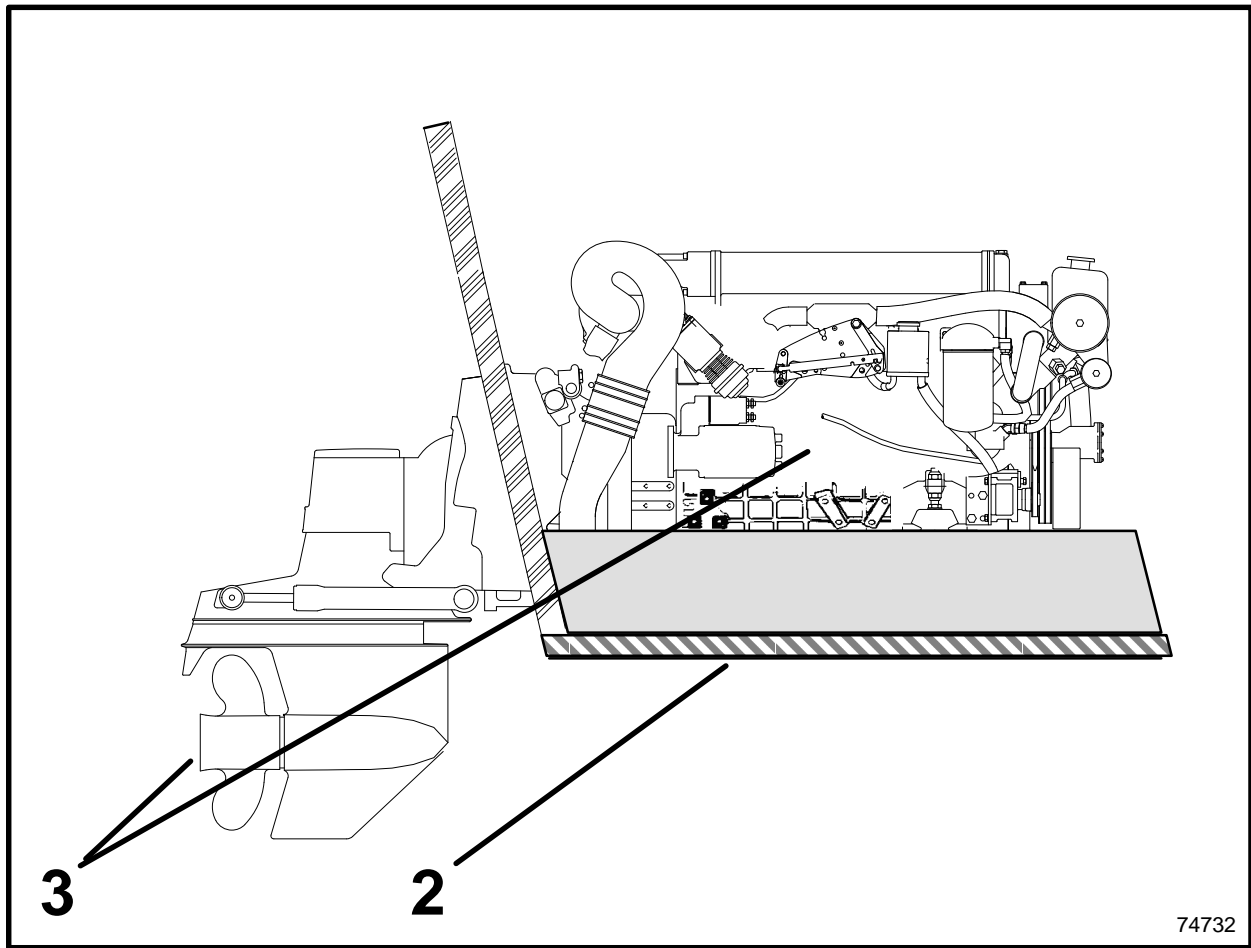
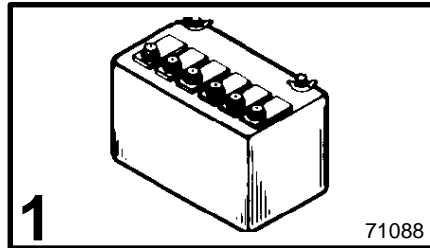

Miscellaneous Maintenance

CA103

Battery

1 All lead acid batteries discharge when not in use. Recharge every 30 to 45 days, or when specific gravity drops below battery manufacturer's specifications.

Refer to specific instructions and warnings accompanying your battery. If this information is not available, observe the following precautions when handling a battery.

WARNING

Do not use jumper cables and a booster battery to start engine. Do not recharge a weak battery in the boat. Remove battery and recharge in a ventilated area away from fuel vapors, sparks or flames.

WARNING

Batteries contain acid which can cause severe burns - Avoid contact with skin, eyes and clothing Batteries also produce hydrogen and oxygen gasses when being charged. This explosive gas escapes fill/vent cell caps, and may form an explosive atmosphere around the battery for several hours after it has been charged; sparks or flames can ignite the gas and cause an explosion which may shatter the battery and could cause blindness or other serious injury.

Safety glasses and rubber gloves are recommended when handling batteries or filling with electrolyte. Hydrogen gases that escape from the battery during charging are explosive. When charging batteries, be sure area where batteries are located, is well-vented. Battery electrolyte is a corrosive acid and should be handled with care. If electrolyte is spilled or splashed on any part of the body, immediately flush the exposed area with liberal amounts of water and obtain medical aid as soon as possible.

CA104

Bottom Of Boat

2 To maintain maximum speed, the following conditions of the boat bottom should be observed:

- Clean, free of barnacles and marine growth.
- Free of distortion, nearly flat where it contacts water.
- Straight and smooth fore and aft.

ANTIFOULING PAINTS

Refer to Antifouling Paint recommendations and related information on previous pages.

Refer to CORROSION AND CORROSION PROTECTION for additional information.

CE70

Inspection And Maintenance

3 Inspect and/or maintain the following:

- Inspect power package often, and at regular intervals, to help maintain its top operating performance, and correct potential problems before they occur. The entire power package should be checked carefully including all accessible engine parts.
- Check for loose, damaged or missing parts, hoses and clamps; tighten or replace as required.
- Remove and inspect propeller. If badly nicked, bent or cracked, see your dealer.
- Repair nicks and corrosion damage on power package exterior finish. Use Quicksilver spray paints - see your Authorized MerCruiser Dealer.
- Spray power package components on inside of boat every 2-3 weeks with Quicksilver Corrosion Guard to protect finish from dulling and corrosion. External power package components may also be sprayed.
- All lubrication points (especially steering system, shift and throttle linkages) should be kept well lubricated.
- Flush seawater cooling circuit periodically (preferably after each use).

Cold Weather Or Extended Storage

Power Package Layup

IMPORTANT: MerCruiser strongly recommends that this service should be performed by an Authorized MerCruiser Dealer. Damage caused by freezing IS NOT covered by the MerCruiser Limited Warranty.

CA115

Battery Winter Storage

Follow battery manufacturer's instructions for storage.

CD360

Power Package Recommissioning

WARNING

To prevent possible injury or damage to equipment, do not install battery until all maintenance has been performed on engine.

- 1 Check that all cooling system hoses are in good condition, connected properly, and hose clamps are tight.
- 2 Install seawater pump impeller, as follows:.

IMPORTANT: Use new gasket. Install in correct position - wide surface (D) on side of cam.

- Place impeller in pump and press onto pump shaft firmly.
- Install pump cover, with gasket, and tighten screws securely.

- 3 Replace fuel filter.
- 4 Bleed fuel system (see "MAINTENANCE - FUEL SYSTEM").

CAUTION

When installing battery, be sure to connect **POSITIVE (+)** battery cable to **POSITIVE (+)** battery terminal **FIRST**, and **NEGATIVE (-)** battery cable to **NEGATIVE (-)** battery terminal **LAST**. If battery cables are reversed, or connection order is reversed, electrical system damage will result.

- 5 Install fully-charged battery. Clean battery cable clamps and terminals and reconnect cables (see **CAUTION** listed above). Secure each cable clamp when connecting. Coat terminals with a battery terminal anti-corrosion spray to help retard corrosion.
- 6 Perform all checks on OPERATION CHART in the STARTING PROCEDURE column.

IMPORTANT: On D3.6L/180 and D4.2L/220 Engines: After not having been operated for two months or longer, it is necessary to pre-lubricate the engine. To do this, hold the "STOP" switch toggle lever **DOWN** while you simultaneously turn the key switch to "START" position for 15 seconds. This will rotate the starter motor and engine/oil pump. During this process the engine will not run because no fuel is injected. Allow the starter motor to cool down for one minute and repeat the above described process. To avoid overheating the starter motor, do not engage starter motor for more than 15 seconds each time.

- 7 Pre-lubricate the engine if necessary. Refer to above "Important" information. Start engine and closely observe instrumentation to make sure that all systems are functioning correctly.
- 8 Carefully inspect engine for fuel, oil, fluid, water and exhaust leaks.
- 9 Check steering system, shift and throttle control for proper operation.

Troubleshooting

CD361

Starter Motor Will Not Crank Engine, Or Cranks It Very Slowly

Possible Cause	Remedy
<ul style="list-style-type: none"> • Battery switch turned off • Remote control not in neutral position • Open circuit breaker or blown fuse • Loose or dirty electrical connections or damaged wiring • Bad battery 	<ul style="list-style-type: none"> • Turn switch on. • Position control lever in neutral. • Check and reset circuit breaker or replace fuse. • Check all electrical connections and wires (especially battery cables). Clean and tighten faulty connection. • Test and replace if bad.

Engine Will Not Start, Or Is Hard To Start

Possible Cause	Remedy
<ul style="list-style-type: none"> • Improper starting procedure • Empty fuel tank or fuel shutoff valve closed • Faulty mechanical fuel delivery pump • Throttle not operating properly • Faulty electrical stop-circuit • Clogged fuel filters • Stale or contaminated fuel • Fuel line or tank vent line kinked or clogged • Air in fuel injection system • Glow-plugs or glow-plug system inoperative, if so equipped • EDI System fault. 	<ul style="list-style-type: none"> • Read starting procedure. • Fill tank or open valve. • Have pump replaced by an Authorized MerCruiser Dealer, if fuel is present. • Check throttle for freedom of movement. • Have Authorized MerCruiser Dealer service electric stop-circuit. • Replace filters. • If contaminated, drain tank. Fill with fresh fuel. • Replace kinked lines or blow out lines with compressed air to remove obstruction. • Purge fuel injection system. • Test, and repair or replace components • Have EDI System checked by an Authorized MerCruiser Dealer.

Engine Runs Rough, Misses And/Or Backfires

Possible Cause	Remedy
<ul style="list-style-type: none">• Throttle not operating properly	<ul style="list-style-type: none">• Check throttle linkages for binding or an obstruction.
<ul style="list-style-type: none">• Idle speed too low	<ul style="list-style-type: none">• Check idle speed and adjust, if necessary.
<ul style="list-style-type: none">• Clogged fuel or air filters	<ul style="list-style-type: none">• Replace filters.
<ul style="list-style-type: none">• Stale or contaminated fuel	<ul style="list-style-type: none">• If contaminated, drain tank. Fill with fresh fuel.
<ul style="list-style-type: none">• Kinked or clogged fuel line or fuel tank vent line	<ul style="list-style-type: none">• Replace kinked line or blow out line with compressed air to remove obstruction.
<ul style="list-style-type: none">• Air in fuel injection system	<ul style="list-style-type: none">• Purge fuel injection system.
<ul style="list-style-type: none">• EDI System fault.	<ul style="list-style-type: none">• Have EDI System checked by an Authorized MerCruiser Dealer.

Poor Performance

Possible Cause	Remedy
<ul style="list-style-type: none">• Throttle not fully open	<ul style="list-style-type: none">• Inspect throttle cable and linkages for operation.
<ul style="list-style-type: none">• Damaged or improper propeller	<ul style="list-style-type: none">• Replace.
<ul style="list-style-type: none">• Excessive bilge water	<ul style="list-style-type: none">• Drain and check for cause of entry.
<ul style="list-style-type: none">• Boat overloaded or load improperly distributed	<ul style="list-style-type: none">• Reduce load or redistribute load more evenly.
<ul style="list-style-type: none">• Boat bottom fouled or damaged	<ul style="list-style-type: none">• Clean or repair as necessary.
<ul style="list-style-type: none">• EDI System fault.	<ul style="list-style-type: none">• Have EDI System checked by an Authorized MerCruiser Dealer.

Excessive Engine Temperature

Possible Cause	Remedy
<ul style="list-style-type: none">• Seacock closed, if so equipped• Drive belt loose or in poor condition• Seawater pickups obstructed• Faulty thermostat• Coolant level low in closed cooling section• Heat exchanger cores plugged with foreign material• Loss of pressure in closed cooling section• Closed cooling section dirty• Faulty seawater pickup pump• Seawater discharge restricted or plugged• Seawater inlet hose kinked (restricted)• Use of improperly designed hose on inlet side of seawater pump allowing it to collapse	<ul style="list-style-type: none">• Open.• Replace and/or adjust belt.• Remove obstruction.• Replace.• Check for cause of low coolant level and repair. Fill system with proper coolant solution.• Clean seawater side of water/water heat exchanger, and seawater strainer.• Check for leaks. Clean, inspect and test pressure cap.• Clean and flush.• Repair.• Clean exhaust elbow.• Position hose to prevent kinking (restriction).• Replace hose with wire reinforced design.

Insufficient Engine Temperature

Possible Cause	Remedy
<ul style="list-style-type: none">• Faulty thermostats	<ul style="list-style-type: none">• Replace.

Low Engine Oil Pressure

Possible Cause	Remedy
<ul style="list-style-type: none">• Faulty senders• Insufficient oil in crankcase• Excessive oil in crankcase (causing it to become aerated)• Diluted or improper viscosity oil	<ul style="list-style-type: none">• Have system checked by an Authorized MerCruiser Dealer.• Check and add oil.• Check and remove required amount of oil. Check for cause of excessive oil (improper filling, bad fuel pump, etc.).• Change oil and oil filter, using correct grade and viscosity oil. Determine cause for dilution (excessive idling, faulty fuel pump, etc.).

Battery Will Not Come Up On Charge

Possible Cause	Remedy
<ul style="list-style-type: none">• Excessive current draw from battery• Loose or dirty electrical connections or damaged wiring• Alternator drive belt loose or in poor condition• Unacceptable battery condition	<ul style="list-style-type: none">• Turn off non-essential accessories.• Check all associated electrical connections and wires (especially battery cables). Clean and tighten faulty connections. Repair or replace damaged wiring.• Replace and/or adjust.• Test battery.

Remote Control Operates Hard, Binds, Has Excessive Free-play Or Makes Unusual Sounds

Possible Cause	Remedy
<ul style="list-style-type: none">• Insufficient lubrication on shift and throttle linkage fasteners• Loose or missing shift and throttle linkage fasteners• Obstruction in shift or throttle linkages• Shift or throttle cable kinked• Improper shift cable adjustment.• Vacuum leak at shift cylinder, hose or fittings of Power Shift Assembly, if so equipped	<ul style="list-style-type: none">• Lubricate.• Check all linkages. If any are loose or missing, see Authorized MerCruiser Dealer immediately.• Remove obstruction.• Straighten cable, or have dealer replace cable if damaged beyond repair.• See Authorized MerCruiser Dealer immediately for shift cable adjustment .• Repair cut, pinched, or kinked hose or faulty shift cylinder.

Steering Wheel Turns Hard Or Jerky

Possible Cause	Remedy
<ul style="list-style-type: none"> • Low power steering pump fluid level • Drive belt loose or in poor condition • Insufficient lubrication on steering system components • Insufficient lubrication on transom gimbal housing assembly and swivel shaft • Loose or missing steering fasteners or parts 	<ul style="list-style-type: none"> • Refill system with fluid. • Replace and/or adjust. • Lubricate. • Lubricate.
<ul style="list-style-type: none"> • Contaminated power steering fluid 	<ul style="list-style-type: none"> • Check all parts and fasteners. If any are loose or missing, see Authorized MerCruiser Dealer immediately. • Drain and replace.

Power Trim Does Not Operate (Electric Motor Does Not Run)

Possible Cause	Remedy
<ul style="list-style-type: none"> • Blown Fuse • Loose or dirty electrical connections or damaged wiring 	<ul style="list-style-type: none"> • Replace fuse. • Check all associated electrical connections and wires (especially battery cables). Clean and tighten faulty connection. Repair or replace wiring.

Power Trim Does Not Operate (Electric Motor Runs But Drive Unit Does Not Move)

Possible Cause	Remedy
<ul style="list-style-type: none"> • Pump oil level low • Drive unit binding in gimbal ring 	<ul style="list-style-type: none"> • Fill pump with oil. • Check for obstruction.

Warranty Information

Owner Warranty Registration

UNITED STATES AND CANADA ONLY

- It is important that your selling dealer fills out the Warranty Registration Card completely and mails it to the factory immediately upon sale of the new product.
- It identifies name and address of the original purchaser, product model and serial number(s), date of sale, type of use and selling dealer's code, name and address. The dealer also certifies that you are the original purchaser and user of the product.
- Upon receipt of the Warranty Registration Card at the factory, you will be issued a plastic Owner Warranty Registration Card which is your only valid registration identification. It must be presented to the servicing dealer should warranty service be required. Warranty claims will not be accepted without presentation of this card.
- A temporary Owner Warranty Registration Card will be presented to you when you purchase the product. It is valid only for 30 days from date of sale while your plastic Owner Warranty Registration Card is being processed. Should your product need service during this period, present the temporary registration card to the dealer. He will attach it to your warranty claim form.
- Because of your selling dealer's continuing personal interest in your satisfaction, the product should be returned to him for warranty service.
- If your plastic card is not received within 30 days from date of new product sale, please contact your selling dealer.
- The product warranty is not effective until the product is registered at the factory.
- NOTICE: Registration lists must be maintained by factory and dealer on marine products sold in the United States, should notification under the federal boat safety act be required.

International Owner Registration

OUTSIDE THE UNITED STATES AND CANADA

- It is important that your selling dealer fills out the Warranty Registration Card completely and mails it to the distributor or Marine Power Service Center responsible for administering the warranty registration/claim program for your area.
- The Warranty Registration Card identifies your name and address, product model and serial number(s), date of sale, type of use and the selling distributors/dealer's code number, name and address. The distributor/dealer also certifies that you are the original purchaser and user of the product.
- A copy of the Warranty Registration Card, designated as the "Purchaser's Copy", MUST be given to you immediately after the card has been completely filled out by the selling distributor/dealer. This card represents your factory registration identification, and should be retained by you for future use when required. Should you ever require warranty service on this product, your dealer may ask you for the Warranty Registration Card to verify date of purchase and to use the information on the card to prepare the warranty claim form(s).
- In some countries, the Marine Power Service Center will issue you a permanent (plastic) Warranty Registration Card within 30 days after receiving the "Factory Copy" of the Warranty Registration Card from your distributor/dealer. If you receive a plastic Warranty Registration Card, you may discard the "Purchaser's Copy" that you received from the distributor/dealer when you purchased the product. Ask your distributor/dealer if this plastic card program applies to you.
- For further information concerning the Warranty Registration Card and its relationship to Warranty Claim processing, refer to the "International Warranty." Refer to "Table of Contents."

IMPORTANT: Registration lists must be maintained by the factory and dealer in some countries by law. It is our desire to have ALL products registered at the factory should it ever be necessary to contact you. Make sure your dealer/distributor fills out the warranty registration card immediately and sends the factory copy to the Marine Power International Service Center for your area.

Warranty Policy

MerCruiser Diesel Limited Warranty

- I. We warrant each new production MerCruiser Diesel Stern Drive Power Package, Inboard Engine and Accessories attached thereto (hereafter referred to as "Product"), manufactured by MerCruiser (hereafter referred to as the "Company"), and sold to the consumer in a country to which distribution is authorized by the Company, to be free from defects in material and workmanship. This warranty shall apply only to pleasure craft and light-duty craft applications.
- II. This warranty shall become effective upon the date of sale to the first purchaser or user of the Product. The warranty period for Pleasure Craft applications is one (1) year from date of sale to the first purchaser or user of the product. The warranty period for Light-Duty Craft applications is one (1) year from date of sale to the first purchaser or user of the product, or the accumulation of 500 hours of engine operation, whichever occurs first. The unused period of the applicable warranty, if any, is transferable to subsequent purchasers. If the law applicable in the Country, State or Province where the product is sold prohibits limitation of warranty coverage to one (1) year, then the warranty shall be the minimum period required by law. For purposes of this warranty Pleasure Craft is defined as a recreational planing craft used only and exclusively for pleasure and recreation. Light-Duty Craft is defined as a planing hull vessel used in any law enforcement, commercial, or professional entertainment activity, or used in any enterprise or venture in which revenue in any amount is generated directly or indirectly.
- III. To validate the warranty, the "Warranty Registration Card", included with each Product, must be properly completed by the selling dealer and forwarded immediately after the sale to Mercury Marine (U.S.A. and Canada) or to a Marine Power International Branch, or Distributor Service Office (outside the U.S.A. and Canada).
- IV. Purchaser must provide proof of purchase and substantiate the original date of sale by presenting to the dealer, authorized to service the Product, the original purchaser's copy of the "Warranty Registration Card" or the "Owner Warranty Registration Card". If either of these items is not available, purchaser must provide a copy of the original purchaser's "Bill of Sale" (Sales Contract) for the Product to be serviced. Warranty claims will not be accepted by the dealer until the original date of sale and Product serial number can be verified.
- V. It is a condition for the continuation of this warranty that the Product be taken to an authorized MerCruiser Service Dealer, after 20 hours of engine operation, but not later than 50 hours, for required checks and adjustments. A copy of the dealer service work order must be retained as evidence of the completion of this requirement.
- VI. Since this warranty applies to defects in material or workmanship, it does not apply to normal wear, adjustments, tune-ups or to damage caused by: 1) Neglect, lack of maintenance, accident, abnormal operation, improper installation or service; 2) Use of a propeller not properly suited to application/boat load or, failure to follow instructions in applicable service and warranty information manuals or operation and maintenance manual; 3) Use of an accessory or part not manufactured or sold by us; 4) Operation with fuels, oils, lubricants or coolants/coolant additives which are not suitable for use with the Product or recommended by us; 5) Participating in or preparing for racing or other competitive activity or operating with racing type lower unit; 6) Alteration or removal of parts; 7) Water entering engine cylinder/s through the exhaust system or air intake system; 8) Use of product in a full-displacement or semi-displacement hull vessel; or 9) Use or operation of the product in a manner inconsistent with the "Recommended Operation/Duty Cycle" section of the Operation and Maintenance Manual.

MerCruiser Diesel Limited Warranty (continued)

- VII.** Reasonable access must be provided to the Product for warranty service. This warranty will not apply to: 1) Haul-out, launch, towing and storage charges, telephone or rental charges of any type, inconvenience, or loss of time or income, or other consequential damages; or 2) Removal and/or replacement of boat partitions or material because of boat design for necessary access to the Product.
- VIII.** Claim shall be made under this warranty by delivering the Product for inspection to a MerCruiser dealer authorized to service the Product. If purchaser cannot deliver Product to such authorized dealer, he may give notice in writing to the Company (U.S.A. and Canada) or the nearest Marine Power International Branch or Distributor Service Office (outside the U.S.A. and Canada). We shall then arrange for the inspection and repair, provided such service is covered under this warranty. Purchaser shall pay for all related transportation charges and/or travel time. If the service is not covered by this warranty, purchaser shall pay for all related labor and material, and any other expenses associated with that service. Any Product or parts shipped by purchaser for inspection or repair must be shipped with transportation charges prepaid.
- IX.** Our obligation under this warranty shall be limited to repairing a defective part or, at our option, refunding the purchase price or replacing such part or parts as shall be necessary to remedy any malfunction resulting from defects in material or workmanship as covered by this warranty. The repair or replacement of parts, or the performance of service, under this warranty, does not extend the period of this warranty beyond its original expiration date. We reserve the right to improve the design of any Product without assuming any obligation to modify any Product previously manufactured.
- X.** ALL INCIDENTAL AND/OR CONSEQUENTIAL DAMAGES ARE EXCLUDED FROM THIS WARRANTY. WARRANTIES OF MERCHANTABILITY AND FITNESS ARE EXCLUDED FROM THIS WARRANTY. IMPLIED WARRANTIES ARE LIMITED TO THE LIFE OF THIS WARRANTY. SOME STATES OR COUNTRIES DO NOT ALLOW LIMITATIONS ON HOW LONG AN IMPLIED WARRANTY LASTS OR THE EXCLUSION OR LIMITATION OF INCIDENTAL OR CONSEQUENTIAL DAMAGES, SO THE ABOVE LIMITATION OR EXCLUSIONS MAY NOT APPLY TO YOU.
- XI.** This warranty gives you specific legal rights and you may also have other legal rights which vary from state to state and country to country.

Marine Power International Branch or Distributor Service Offices

INTERNATIONAL HEADQUARTERS

**Marine Power International
Division of Brunswick Corporation
P.O. Box 1939
Fond du Lac, WI 54936-1939
USA
Telephone: (414) 929-5000**

EUROPE, MIDDLE EAST, AFRICA

**Marine Power Europe, Inc.
Parc Industriel de Petit-Rechain
B-4800 Verviers
Belgium
Telephone (0) 87 / 32 • 32 • 11
Fax (32) (87) 31 • 19 • 65**

LATIN AMERICA, CARIBBEAN

**Marine Power International
9350 SW 72nd St. (Sunset Dr.)
Suite 100
Miami, FL 33173
U.S.A.
Telephone (305) 596-9606
Fax (305) 596-3869**

AUSTRALIA

**Marine Power International Pty. Ltd.
P. B. 1420, 132-140 Frankston Road
Dandenong, Victoria 3164
Australia
Telephone (61) (3) 791-5822
Fax (61) (3) 791-5880**

ASIA / PACIFIC

**Marine Power International, Ltd.
Block 1002 Jalan Bukit Merah #07-08
Redhill Industrial Estate
JTC Flatted Factories
Singapore 0315
Telephone (65) 270-7680
Fax (65) 270-7898**

JAPAN

**Marine Power International - Japan
No. 27-2 Muramatsu Chisaki-shinden
Shimizu City
Shizuoka Prefecture
Japan 424
Telephone (81) 543/34-2500
Fax (81) 543/34-2022**

Warranty Coverage

The purpose of this section is to help eliminate some of the more common misunderstandings regarding warranty coverage. The table explains some of the types of services that are not covered by warranty.

Keep in mind that warranty covers repairs that are needed within the warranty period because of defects in material and workmanship. Installation errors, accidents normal wear and a variety of other causes that affect the product are not covered.

Warranty is limited to defects in material or workmanship, but only when the consumer sale is made in the country to which distribution is authorized by us.

Should you have any questions concerning warranty coverage contact your authorized dealer. They will be pleased to answer any questions that you may have.

WARRANTY DOES NOT APPLY TO THE FOLLOWING:

- Minor adjustments or checks, including checking fuel injection pump timing, cleaning fuel injectors, filters, or adjusting belts, controls, and checking lubrication made in connection with normal services.
- Damage caused by neglect, lack of maintenance, accident, abnormal operation, improper installation or service, or freezing temperatures.
- Haul-out, launch, towing charges; removal and/or replacement of boat partitions or material because of boat design for necessary access to the product; all related transportation charges and/or travel time, etc. Reasonable access must be provided to the product for warranty service. Customer must deliver product to an Authorized Dealer.
- Additional service work requested by customer other than that necessary to satisfy the warranty obligation.
- Labor performed by other than an Authorized Dealer may be covered only under following circumstances: When performed on emergency basis (providing there are no Authorized Dealers in area who can perform the work required or have no facilities to haul out, etc., and prior factory approval has been given to have the work performed at this facility).
- All incidental and/or consequential damages (storage charges, telephone or rental charges of any type, inconvenience or loss of time or income) are the owner's responsibility.
- Use of other than Quicksilver replacement parts when making warranty repairs.
- Oils, lubricants or fluids changed as a matter of normal maintenance is customer's responsibility unless loss or contamination of same is caused by product failure that would be eligible for warranty consideration.
- Participating in or preparing for racing or other competitive activity.
- Engine noise does not necessarily indicate a serious engine problem. If diagnosis indicates a serious internal engine condition which could result in a failure, condition responsible for noise should be corrected under the warranty.
- Lower unit and/or propeller damage caused by striking a submerged object is considered a marine hazard.
- Water entering the engine via the air filter or exhaust system or submersion. Also, water in the starter motor.
- Starter motors and/or armatures or field coil assembly, which are burned, or where lead is thrown out of commutator because of excess cranking.
- Valve or valve seat grinding required because wear.
- Failure of any parts caused by lack of cooling water, which results from starting power package out of water, foreign material blocking inlets or power package being mounted too high.
- Use of fuels and lubricants which are not suitable for use with or on the product. Refer to your Operation and Maintenance Manual.
- Our limited warranty does not apply to any damage to our products caused by the installation or use of parts and accessories which are not manufactured or sold by us. Failures which are not related to the use of those parts or accessories, are covered under warranty, if they otherwise meet the terms of the limited warranty for that product.

Transferable Warranty

The product warranty is transferable to a subsequent purchaser, but only for the remainder of the unused portion of the limited warranty. This will not apply to products used for commercial applications.

DIRECT SALE BY OWNER

- The second owner can be registered as the new owner and retain the unused portion of the limited warranty by sending the former owner's plastic Owner Warranty Registration Card and a copy of the bill of sale to show proof of ownership. In the United States and Canada, mail to:

Mercury Marine
W6250 West Pioneer Road
P.O. Box 1939
Fond du Lac, WI 54936-1939
Attn: Warranty Registration Department

- A new Owner Warranty Registration Card will be issued with the new owner's name and address. Registration records will be changed on the factory computer registration file.
- There is no charge for this service.

Outside the United States and Canada, please contact the distributor in your country, or the Marine Power International Service Center closest to you, for the transferable warranty procedure that would apply to you.

Q-GUARD Product Protection Plan

UNITED STATES AND CANADA ONLY

(Certain Performance Products, triple engine installations, and commercial applications are excluded)

The Mercury Marine Q-GUARD Product Protection Plan provides coverage against unexpected mechanical and electrical breakdowns that may occur beyond the standard limited warranty.

The optional Q-GUARD Product Protection Plan is the only Factory Plan available for your engine.

Two, three or four-year plans can be purchased up to 180 days after the original engine purchase date.

See your participating dealer for complete program details.

Owner Service Assistance

Local Repair Service

Always return your MerCruiser powered boat to your local Authorized Dealer, should the need for service arise. Only he has the factory trained mechanics, knowledge, special tools and equipment and the genuine Quicksilver parts and accessories* to properly service your engine should the need occur. He knows your engine best.

* Quicksilver parts and accessories are engineered and built by Mercury Marine, specifically for MerCruiser® stern drives and inboards.

Service Away From Home

If you are away from your local dealer and the need arises for service, contact the nearest Authorized Dealer. Refer to the Yellow Pages of the telephone directory. If, for any reason, you cannot obtain service, contact the nearest Regional Service Center. Outside the United States and Canada, contact the nearest Marine Power International Service Center.

Parts And Accessories Inquiries

All inquiries concerning Quicksilver replacement parts and accessories should be directed to your local Authorized Dealer. The dealer has the necessary information to order parts and accessories for you should he not have them in stock. Only Authorized Dealers can purchase genuine Quicksilver parts and accessories from the factory. Mercury Marine does not sell to unauthorized dealers or retail customers. When inquiring on parts and accessories, the dealer requires the **motor model** and **serial number(s)** to order the correct parts.

CB577

Resolving A Problem

Satisfaction with your MerCruiser product is very important to your dealer and to us. If you ever have a problem, question or concern about your power package, contact your dealer or any Authorized MerCruiser Dealership. If additional assistance is required, take these steps.

- 1 *Talk with the dealership's sales manager or service manager. If this has already been done, then contact the owner of the dealership.*
- 2 *Should you have a question, concern or problem that cannot be resolved by your dealership, please contact Mercury Marine Service Office for assistance. Mercury Marine will work with you and your dealership to resolve all problems.*

The following information will be needed by the service office:

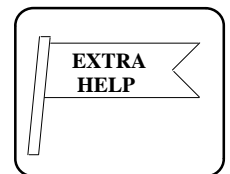
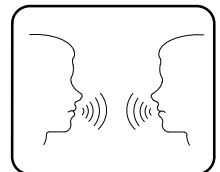

- Your name and address
- Daytime telephone number
- Model and serial number for your power package
- The name and address of your dealership
- Nature of problem

Mercury Marine Service Offices are listed on the next page.



Mercury Marine Service Offices

For assistance, call, fax, or write. Please include your daytime telephone number with mail and fax correspondence.

Telephone 	Fax 	Mail 
United States		
(405) 743-6566	(405) 743-6570	MerCruiser 3003 N. Perkins Rd. Stillwater, OK 74075
Canada		
(905) 270-4481	(905) 270-4510	Mercury Marine Ltd. 1156 Dundas Hwy. E. Mississauga, Ontario Canada L4Y 2C2
Australia, Pacific		
(61) (3) 791-5822	(61) (3) 793-5880	Mercury Marine Australia 132-140 Frankston Road Dandenong, Victoria 3164 Australia
Europe, Middle East, Africa		
(32) (87) 32 • 32 • 11	(32) (87) 31 • 19 • 65	Marine Power - Europe, Inc. Parc Industriel de Petit-Rechain B-4800 Verviers Belgium
Mexico, Central America, South America, Caribbean		
(305) 385-9585	(305) 385-5507	Mercury Marine - Latin America & Caribbean 9010 S.W. 137th Ave. Suite 226 Miami, FL 33186 U.S.A.
Japan		
(81) 543/34-2500	(81) 543/34-2022	Mercury Marine - Japan No. 27-2 Muramatsu Chisaki-Shinden Shimizu City Shizuoka Prefecture Japan 424
Asia, Singapore		
(65) 270-7680	(65) 270-7898	Marine Power International, Ltd. Block 1002 Jalan Bukit Merah #07-08 Redhill Industrial Estate JTC Flatted Factories Singapore 0315

Customer Service Literature

English Language

English language publications are available from:

Mercury Marine
Attn: Publications Department
W6250 West Pioneer Road
P.O. Box 1939
Fond du Lac, WI 54936-1939

Outside the United States and Canada, contact the nearest Mercury Marine or Marine Power International Service Center for further information.

When ordering be sure to:

1. List your product, model, year and serial number(s).
2. Check the literature and quantities you want.
3. Enclose full remittance in check or money order (NO C.O.D.'s).

CA464

Other Languages

To obtain an Operation and Maintenance Manual or Maintenance Procedures Manual in another language, contact the nearest Mercury Marine or Marine Power International Service Center for information. A list of part numbers for other languages is provided with your power package.

caa464

Andre sprog

Kontakt det nærmeste Mercury Marine eller Marine Power International service center for oplysninger om hvordan du kan anskaffe en Betjenings- og vedligeholdelsesmanual eller en manual med vedligeholdelsesprocedurer på et andet sprog. En liste med reservedelsnumre for andre sprog leveres sammen med din power-pakke.

cab464

Andere talen

Voor het verkrijgen van een Handleiding voor gebruik en onderhoud of een Onderhoudshandleiding in andere talen dient u contact op te nemen met het dichtstbijzijnde internationale servicecentrum van Mercury Marine of Marine Power voor informatie hierover. Een lijst met onderdeelnummers voor andere talen wordt bij uw motorinstallatie geleverd.

cac464

Muut kielet

Saadaksesi Käyttö- ja huolto-ohjekirjoja muilla kielillä, ota yhteys lähimpään Mercury Marine tai Marine Power International huoltokeskukseen, josta saat lähempiä tietoja. Moottorisi mukana seuraa monikielinen varaosa-numeroluettelo.

cad464

Autres langues

Pour obtenir un Manuel d'utilisation et d'entretien ou un Manuel d'entretien dans une autre langue, contactez le centre de service après-vente international Mercury Marine ou Marine Power le plus proche pour toute information. Une liste des numéros de pièces en d'autres langues accompagne votre bloc-moteur.

cae464

Andere Sprachen

Um eine Betriebs- und Wartungsanleitung oder ein Handbuch der Wartungsverfahren in einer anderen Sprache zu erhalten, wenden Sie sich an das nächste Mercury Marine oder Marine Power International Service Center. Eine Liste mit Teilenummern für Fremdsprachen ist im Lieferumfang Ihres Motors enthalten.

caf464

Altre lingue

Per ottenere il manuale di funzionamento e manutenzione o il manuale delle procedure di manutenzione in altra lingua, contattate il centro assistenza internazionale Mercury Marine o Marine Power più vicino. In dotazione con il gruppo motore, viene fornito l'elenco dei codici prodotto dei componenti venduti all'estero.

Andre språk

Ytterligere informasjon om bruks- og vedlikeholdshåndbok eller servicehåndbok på andre språk kan fås ved henvendelse til nærmeste internasjonale servicecenter for Mercury Marine eller Marine Power. En liste over delenumre for andre språk følger med aggregatet.

cah464

Outros Idiomas

Para obter um Manual de Operação e Manutenção ou um Manual de Procedimentos de Manutenção em outro idioma, contate o Centro de Serviço Internacional de "Marine Power" (Potência Marinha) ou a Mercury Marine mais próxima para obter informações. Uma lista de números de referência para outros idiomas é fornecida com o seu pacote de propulsão.

caj464

Otros idiomas

Para obtener un Manual de operación y mantenimiento o un Manual de procedimientos en otro idioma, póngase en contacto con el centro de servicio más cercano de Mercury Marine o Marine Power International para recibir información. Con su conjunto motriz se entrega una lista de los números de pieza para los otros idiomas.

cak464

Andra språk

För att få Instruktions- och underhållsböcker på andra språk, kontakta närmaste Mercury Marine eller Marine Power International servicecenter, som kan ge ytterligare information. En förteckning över artikelnummer på andra språk medföljer ditt kraftpaket.

Literature Order Form

Model _____ Horsepower _____

Serial Number _____ Year _____

Operation and Maintenance Manual (Owner's Guide) - explains basic operation and maintenance.

Maintenance Procedure Manual - explains basic do-it-yourself maintenance procedures.

Service Manual - shows the complete assembly and disassembly of the engine or stern drive.

Parts Manual - shows the exploded view of the engine or stern drive with corresponding part number.

Manual	Part Number <small>(Official Use Only)</small>	Qty.	Price Each	Total Price
Service Manual: Engine	90-		\$30.00	
Service Manual: Drive	90-		\$30.00	
Service Manual: Remote Control	90-		\$30.00	
Parts Manual: Engine Only	90-		\$4.95	
Parts Manual: Drive Only	90-		\$4.95	
Operation and Maintenance Manual	90-		\$5.00	
Maintenance Procedure Manual	90-		\$15.00	
* must be collected from customers in all states except: AK, AZ, DE, HI, ID, IA, ME, MI, MT, NV, NH, NY, OR, VT, WV, WY ** Orders Totaling: up to \$20.00, add \$3.00 20.01 - \$50.00, add \$4.00 50.01 - up, Free			Sub-Total	
			Sales Tax *	
			Ship/Hand**	
			Grand Total	



VM MOTORI S.p.A.

A DETROIT DIESEL CO.



CALIFORNIA

PROPOSITION 65 WARNING

Diesel engine exhaust and some of its constituents are known to the State of California to cause cancer, birth defects, and other reproductive harm.