

SUZUKI OUTBOARD MOTOR

DF90

DF115 *FOUR STROKE*

SERVICE MANUAL



FOREWORD

This manual contains an introductory description on SUZUKI Outboard motor DF90/115 and procedures for the inspection, service and overhaul of its main components.

General knowledge information is not included.

Please read the GENERAL INFORMATION section to familiarize yourself with basic information concerning this motor. Read and refer to the other sections in this manual for information regarding proper inspection and service procedures.

This manual will help you better understand this outboard motor so that you may provide your customers with optimum and quick service.

- This manual has been prepared using the latest information available at the time of publication.

If a modification has been made since then, differences may exist between the content of this manual and the actual outboard motor.

- Illustrations in this manual are used to show the basic principles of operation and work procedures and may not represent the actual outboard motor in exact detail.

- This manual is intended for use by technicians who already possess the basic knowledge and skills to service SUZUKI outboard motors.

Persons without such knowledge and skills should not attempt to service an outboard engine by relying on this manual only.

Instead, please contact your nearby authorized SUZUKI outboard motor dealer.

▲ WARNING

Apprentice mechanics or do-it-yourself mechanics that don't have the proper tools and equipment may not be able to properly perform the services described in this manual. Improper repair may result in injury to the mechanic and may render the engine unsafe for the boat operator and passengers.

NOTE:

This manual is compiled based on 2001 (K1) model.

GROUP INDEX

GENERAL INFORMATION	1
PERIODIC MAINTENANCE	2
ENGINE CONTROL SYSTEM	3
ENGINE ELECTRICAL	4
FUEL SYSTEM	5
POWER UNIT	6
MID UNIT	7
POWER TRIM AND TILT	8
LOWER UNIT	9
WIRE / HOSE ROUTING	10

HOW TO USE THIS MANUAL

TO LOCATE WHAT YOU ARE LOOKING FOR :

1. The text of this manual is divided into sections.
2. The section titles are listed on the previous page in a GROUP INDEX. Select the section needed for reference.
3. Holding the manual as shown at the right will allow you to find the first page of the section easily.
4. The first page of each section lists a table of contents to easily locate the item and page you need.

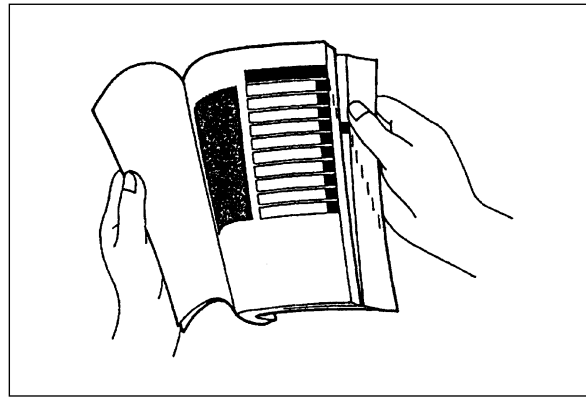

COMPONENT PARTS AND IMPORTANT ITEM ILLUSTRATIONS





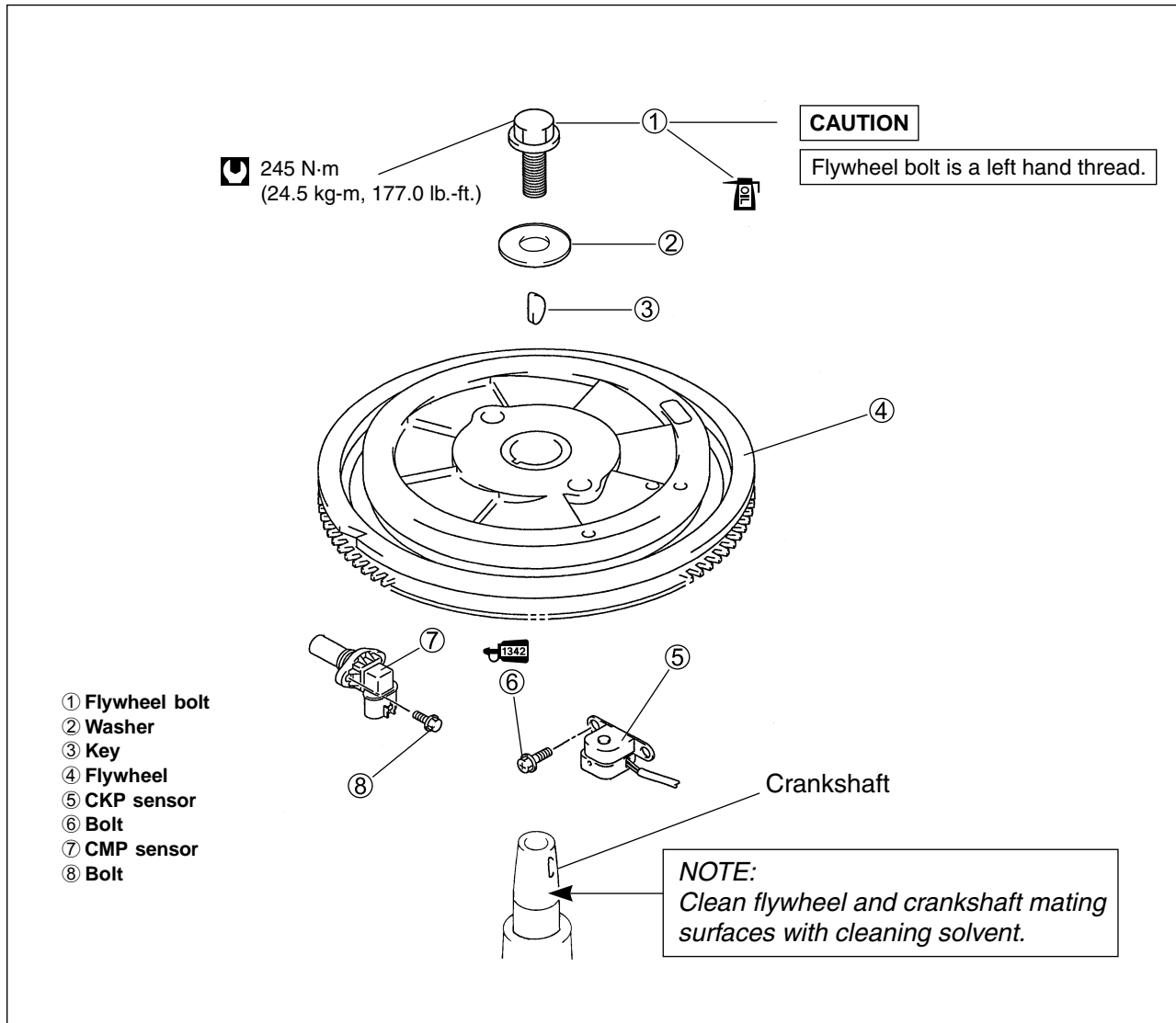









Under the name of each system or unit, an exploded view is provided with work instructions and other service information such as the tightening torque, lubrication and locking agent points.

Example :

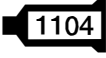

SYMBOL

Listed in the table below are the symbols indicating instructions and other important information necessary for proper servicing. Please note the definition for each symbol. You will find these symbols used throughout this manual. Refer back to this table if you are not sure of any symbol(s) meanings.

SYMBOL	DEFINITION	SYMBOL	DEFINITION
	Torque control required. Data beside it indicates specified torque.		Apply THREAD LOCK "1342".
	Apply oil. Use engine oil unless otherwise specified.		Apply THREAD LOCK SUPER "1333B".
	Apply SUZUKI OUTBOARD MOTOR GEAR OIL.		Measure in DC voltage range.
	Apply SUZUKI SUPER GREASE "A".		Measure in resistance range.
	Apply SUZUKI WATER RESISTANT GREASE.		Measure in continuity test range.
	Apply SUZUKI BOND "1104".		Use peak voltmeter "Stevens CD-77".
	Apply SUZUKI BOND "1207B".		Use special tool.
	Apply SUZUKI SILICONE SEAL.		

GENERAL INFORMATION

1

CONTENTS

WARNING / CAUTION / NOTE _____	1-2
GENERAL PRECAUTIONS _____	1-2
IDENTIFICATION NUMBER LOCATION _____	1-4
FUEL AND OIL _____	1-4
GASOLINE RECOMMENDATION	1-4
ENGINE OIL	1-4
ENGINE BREAK-IN _____	1-5
PROPELLERS _____	1-6
POWERHEAD DIRECTION OF ROTATION _____	1-6
SPECIFICATIONS _____	1-7
SERVICE DATA _____	1-9
TIGHTENING TORQUE _____	1-16
SPECIAL TOOLS _____	1-18
MATERIALS REQUIRED _____	1-21

WARNING / CAUTION / NOTE

Please read this manual and follow its instructions carefully. To emphasize special information, the symbol and the words WARNING, CAUTION and NOTE have special meanings. Pay special attention to the messages highlighted by these signal words.

▲ WARNING

Indicates a potential hazard that could result in death or injury.

CAUTION

Indicates a potential hazard that could result in motor damage.

NOTE:

Indicates special information to make maintenance easier or instructions clearer.

Please note, however, that the warnings and cautions contained in this manual cannot possibly cover all potential hazards relating to the servicing, or lack of servicing, of the outboard motor. In addition to the WARNING and CAUTION stated, you must also use good judgement and observe basic mechanical safety principles.

GENERAL PRECAUTIONS

▲ WARNING

- Proper service and repair procedures are important for the safety of the service mechanic and the safety and reliability of the outboard motor.
- To avoid eye injury, always wear protective goggles when filing metals, working on a grinder, or doing other work, which could cause flying material particles.
- When 2 or more persons work together, pay attention to the safety of each other.
- When it is necessary to run the outboard motor indoors, make sure that exhaust gas is vented outdoors.
- When testing an outboard motor in the water and on a boat, ensure that the necessary safety equipment is on board. Such equipment includes : flotation aids for each person, fire extinguisher, distress signals, anchor, paddles, bilge pump, first-aid kit, emergency starter rope, etc.
- When working with toxic or flammable materials, make sure that the area you work in is well-ventilated and that you follow all of the material manufacturer's instructions.
- Never use gasoline as a cleaning solvent.
- To avoid getting burned, do not touch the engine, engine oil or exhaust system during or shortly after engine operation.
- Oil can be hazardous. Children and pets may be harmed from contact with oil. Keep new and used oil away from children and pets. To minimize your exposure to oil, wear a long sleeve shirt and moisture-proof gloves (such as dishwashing gloves) when changing oil. If oil contacts your skin, wash thoroughly with soap and water. Launder any clothing or rags if wet with oil. Recycle or properly dispose of used oil.
- After servicing fuel, oil / engine cooling system and exhaust system, check all lines and fittings related to the system for leaks.
- Carefully adhere to the battery handling instructions laid out by the battery supplier.

CAUTION

- If parts replacement is necessary, replace the parts with Suzuki Genuine Parts or their equivalent.
- When removing parts that are to be reused, keep them arranged in an orderly manner so that they may be reinstalled in the proper order and orientation.
- Be sure to use special tools when instructed.
- Make sure that all parts used in assembly are clean and also lubricated when specified.
- When use of a certain type of lubricant, bond, or sealant is specified, be sure to use the specified type.
- When removing the battery, disconnect the negative cable first and then the positive cable. When reconnecting the battery, connect the positive cable first and then the negative cable.
- When performing service to electrical parts, if the service procedures do not require using battery power, disconnect the negative cable at the battery.
- Tighten cylinder head and case bolts and nuts, beginning with larger diameter and ending with smaller diameter. Always tighten from inside to outside diagonally to the specified tightening torque.
- Whenever you remove oil seals, gaskets, packing, O-rings, locking washers, locking nuts, cotter pins, circlips, and certain other parts as specified, always replace them with new. Also, before installing these new parts, be sure to remove any left over material from the mating surfaces.
- Never reuse a circlip. When installing a new circlip, take care not to expand the end gap larger than required to slip the circlip over the shaft. After installing a circlip, always ensure that it is completely seated in its groove and securely fitted.
- Use a torque wrench to tighten fasteners to the torque values when specified. Remove grease or oil from screw / bolt threads unless a lubricant is specified.
- After assembly, check parts for tightness and operation.

- To protect the environment, do not unlawfully dispose of used motor oil, other fluids, and batteries.
- To protect the Earth's natural resources, properly dispose of used motor parts.

IDENTIFICATION NUMBER LOCATION

MODEL, PRE-FIX, SERIAL NUMBER

The MODEL, PRE-FIX and SERIAL NUMBER of motor are stamped on a plate attached to the clamp bracket.

Example

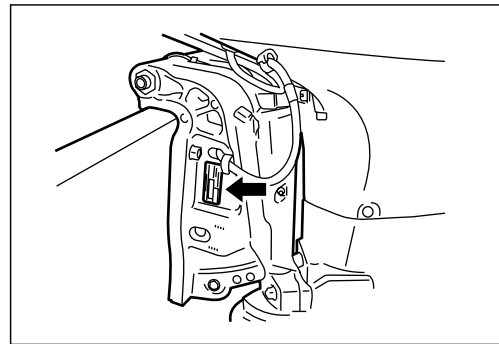
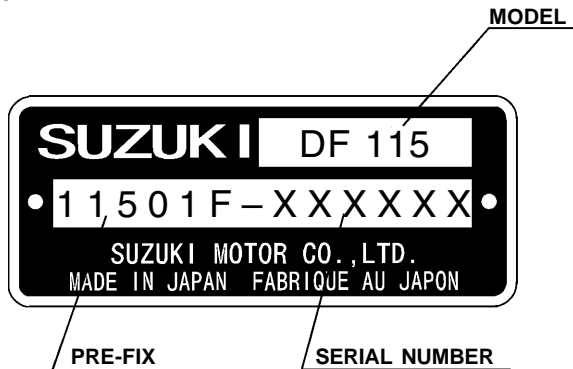

ENGINE SERIAL NUMBER

A second engine serial number plate is pressed into a boss on the cylinder block.

FUEL AND OIL

GASOLINE RECOMMENDATION

Suzuki highly recommends that you use alcohol-free unleaded gasoline with a minimum pump octane rating of 87 (R+M / 2 method) or 91 (Research method). However, blends of unleaded gasoline and alcohol with equivalent octane content may be used.

Allowable maximum blend of a single additive (not combination) :

5% Methanol, 10% Ethanol, 15% MTBE

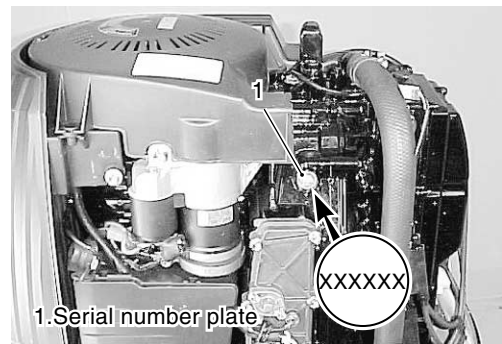

CAUTION

If leaded gasoline is used, engine damage may result.
Use only unleaded gasoline.

ENGINE OIL

Use only oils that are rated SE, SF, SG, SH, or SJ under the API (American Petroleum Institute) classification system.

The viscosity rating should be SAE 10W-40.

If an SAE 10W-40 motor oil is not available, select an alternative according to the chart at right.

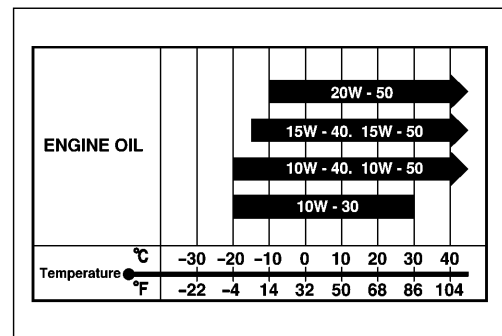

ENGINE BREAK-IN

The first 10 hours are critically important to ensure correct running of either a brand new motor or a motor that has been reconditioned or rebuilt. How the motor is operated during this time will have direct bearing on its life span and long-term durability.

Break-in period : 10 hours

WARM-UP RECOMMENDATION

Allow sufficient idling time (more than 5 minutes) for the engine to warm up after cold engine starting.

THROTTLE RECOMMENDATION

NOTE:

Avoid maintaining a constant engine speed for an extended period at any time during the engine break-in by varying the throttle position occasionally.

1. FIRST 2 HOURS

For first 15 minutes, operate the engine in-gear at idling speed.

During the remaining 1 hour and 45 minutes, operate the engine in-gear at less than 1/2 (half) throttle (3000 r/min.).

NOTE:

The throttle may be briefly opened beyond the recommended setting to plane the boat, but must be reduced to the recommended setting immediately after planing.

2. NEXT 1 HOUR

Operate the engine in-gear at less than 3/4 (three-quarter) throttle (4000 r/min.).

3. LAST 7 HOURS

Operate the engine in-gear at desired engine speed.

However, do not operate continuously at full throttle for more than 5 minutes.

PROPELLERS

An outboard motor is designed to develop its rated power within a specified engine speed range. The maximum rated power delivered by the DF90T/115T models are shown below.

Recommended full throttle speed range	DF90T	4500 – 5500 r/min.
	DF115T	5000 – 6000 r/min.

If the standard propeller fails to meet the above requirement, use another pitch propeller to hold the engine speed within the range specified above.

Propeller selection chart

Blade	×	Diam. (in.)	×	Pitch (in.)
3	×	14	×	17 (X1700)
3	×	14	×	19 (X1900)
3	×	14	×	21 (X2100)
3	×	14	×	23 (X2300)

CAUTION

Installing a propeller with pitch either too high or too low will cause incorrect maximum engine speed, which may result in severe damage to the motor.

POWERHEAD DIRECTION OF ROTATION

This outboard motor is designed with a L.H. (left hand) rotation powerhead utilizing an offset crankshaft.

This design has the advantage of reducing the size of the motor and keeping the overall motor's weight closer to the boat transom and therefore closer to the boat C/G (center of gravity).

Rotation of the driveshaft is accomplished through a crankshaft drive gear and a driveshaft driven gear.

These gears are located beneath the powerhead in the same oil bath location as the camshaft chain.

As the rotational direction of the driven gear will be opposite of the drive gear, a left-hand rotation powerhead design was adopted to retain a conventional, standard rotation (right-hand) propeller shaft output.

***SPECIFICATIONS**

* These specifications are subject to change without notice.

Item	Unit	Data	
		DF90T	DF115T
PRE-FIX		09001F	11501F

DIMENSIONS & WEIGHT

Overall length (front to back)		mm (in.)	779 (30.7)
Overall width (side to side)		mm (in.)	481 (18.9)
Overall height	L	mm (in.)	1556 (61.3)
	UL	mm (in.)	1683 (66.3)
Weight (without engine oil)	L	kg (lbs.)	189.0 (416)
	UL	kg (lbs.)	194.0 (427)
Transom height	L	mm (in. type)	539 (20)
	UL	mm (in. type)	666 (25)

PERFORMANCE

Maximum output	kW (PS)	66.2 (90)	84.6 (115)
Recommended operating range	r/min.	4500 – 5500	5000 – 6000
Idle speed	r/min.	625 ± 25 (in-gear : approx. 625)	

POWERHEAD

Engine type	4-stroke DOHC		
Number of cylinders	4		
Bore	mm (in.)	84.0 (3.31)	
Stroke	mm (in.)	88.0 (3.46)	
Total displacement	cm ³ (cu in.)	1950 (119.0)	
Compression ratio	: 1	9.8	
Spark plug	NGK	BKR6E	
Ignition system	Full-transistorized ignition		
Fuel supply system	Multi-point sequential electronic fuel injection		
Exhaust system	Through prop exhaust		
Cooling system	Water cooled		
Lubrication system	Wet sump by trochoid pump		
Starting system	Electric		
Throttle control	Remote control		

1-8 GENERAL INFORMATION

Item	Unit	Data	
		DF90T	DF115T

FUEL & OIL

Fuel	Suzuki highly recommends that you use alcohol-free unleaded gasoline with a minimum pump octane rating of 87 ($\frac{R+M}{2}$ method) or 91 (Research method). However, blends of unleaded gasoline and alcohol with equivalent octane content may be used.		
Engine oil	API classification SE, SF, SG, SH, SJ Viscosity rating 10W-40		
Engine oil amounts	L (US/Imp. qt)	5.5 (5.8 / 4.8) : Oil change only 5.7 (6.0 / 5.0) : Oil filter change	
Gear oil	SUZUKI Outboard Motor Gear Oil (SAE #90 hypoid gear oil)		
Gearcase oil capacity	ml (US/Imp. oz)	1050 (35.5 / 37.0)	

BRACKET

Trim angle	PTT system		
Number of trim position	PTT system		
Maximum tilt angle	degree	75	

LOWER UNIT

Reversing system	Gear		
Transmission	Forward-Neutral-Reverse		
Reduction system	Bevel gear		
Gear ratio	12 : 25 (2.08)		
Drive line impact protection	Spline drive rubber hub		
Propeller	Blade × Diam. (in.) × Pitch (in.)		
	3	×	14 × 17
	3	×	14 × 19
	3	×	14 × 21
	3	×	14 × 23

REDUCTION SYSTEM

1st reduction gear ratio (Crankshaft drive gear: Driven gear)	29 : 36 (1.24)
2nd reduction gear ratio (Lower unit gear)	12 : 25 (2.08)
Total reduction gear ratio	2.59 $\left(\frac{36}{29} \times \frac{25}{12}\right)$

***SERVICE DATA**

* These service data are subject to change without notice.

Item	Unit	Data	
		DF90T	DF115T

POWERHEAD

Recommended operating range	r/min	4500 – 5500	5000 – 6000
Idle speed	r/min	625 ± 25 (in-gear : approx. 625)	
**Cylinder compression	kPa (kg/cm ² , psi)	1300 – 1700 (13 – 17, 185 – 242)	
**Cylinder compression max. difference between any two cylinders	kPa (kg/cm ² , psi)	100 (1.0, 14)	
**Engine oil pressure	kPa (kg/cm ² , psi)	550 – 600 (5.5 – 6.0, 78 – 85) at 3000 r/min. (at normal operating temp.)	
Engine oil		API classification	SE, SF, SG, SH, SJ
		Viscosity rating	SAE 10W-40
Engine oil amounts	L (US/Imp. qt)	5.5 (5.8 / 4.8) : Oil change only 5.7 (6.0 / 5.0) : Oil filter change	
Thermostat operating temperature	°C (°F)	58 – 62 (136 – 144)	

** Figures shown are guidelines only, not absolute service limits.

1-10 GENERAL INFORMATION

Item	Unit	Data	
		DF90T	DF115T

CYLINDER HEAD/CAMSHAFT

Cylinder head distortion	Limit	mm (in)	0.05 (0.002)
Manifold seating faces distortion	Limit	mm (in)	0.10 (0.004)
Cam height	IN	STD	mm (in) 37.320 – 37.480 (1.4693 – 1.4756) 39.220 – 39.380 (1.5441 – 1.5504)
		Limit	mm (in) 37.220 (1.4654) 39.120 (1.5402)
	EX	STD	mm (in) 37.030 – 37.190 (1.4579 – 1.4642) 39.040 – 39.200 (1.5370 – 1.5433)
		Limit	mm (in) 36.930 (1.4539) 38.940 (1.5330)
Camshaft journal oil clearance	Top, 2nd, 3rd, 4th	STD	mm (in) 0.020 – 0.062 (0.0008 – 0.0024)
		Limit	mm (in) 0.120 (0.0047)
	5th	STD	mm (in) 0.045 – 0.087 (0.0018 – 0.0034)
		Limit	mm (in) 0.120 (0.0047)
Camshaft journal (housing) inside diameter	Top, 2nd, 3rd, 4th	STD	mm (in) 23.000 – 23.021 (0.9055 – 0.9063)
		Limit	mm (in) 23.171 (0.9122)
	5th	STD	mm (in) 26.000 – 26.021 (1.0236 – 1.0244)
		Limit	mm (in) 26.171 (1.0304)
Camshaft journal outside diameter	Top, 2nd, 3rd, 4th	STD	mm (in) 22.959 – 22.980 (0.9039 – 0.9047)
		Limit	mm (in) 22.869 (0.9004)
	5th	STD	mm (in) 25.934 – 25.955 (1.0210 – 1.0219)
		Limit	mm (in) 25.844 (1.0175)
Camshaft runout	Limit	mm (in)	0.10 (0.004)
Cylinder head bore to tappet clearance	STD	mm (in)	0.025 – 0.066 (0.0010 – 0.0026)
	Limit	mm (in)	0.150 (0.0059)
Tappet outer diameter	STD	mm (in)	30.959 – 30.975 (1.2189 – 1.2195)
Cylinder head bore	STD	mm (in)	31.000 – 31.025 (1.2203 – 1.2215)

Item	Unit	Data	
		DF90T	DF115T

VALVE / VALVE GUIDE

Valve diameter	IN		mm (in)	33 (1.3)
	EX		mm (in)	28 (1.1)
Tappet clearance (Cold engine condition)	IN	STD	mm (in)	0.23 – 0.27 (0.009 – 0.011)
	EX	STD	mm (in)	0.23 – 0.27 (0.009 – 0.011)
Valve seat angle	IN		—	15°, 45°, 60°
	EX		—	15°, 45°
Valve guide to valve stem clearance	IN	STD	mm (in)	0.020 – 0.047 (0.0008 – 0.0019)
		Limit	mm (in)	0.070 (0.0028)
	EX	STD	mm (in)	0.045 – 0.072 (0.0018 – 0.0028)
		Limit	mm (in)	0.090 (0.0035)
Valve guide inside diameter	IN,EX	STD	mm (in)	6.000 – 6.012 (0.2362 – 0.2367)
Valve guide protrusion	IN,EX	STD	mm (in)	13.5 (0.53)
Valve stem outside diameter	IN	STD	mm (in)	5.965 – 5.980 (0.2348 – 0.2354)
	EX	STD	mm (in)	5.940 – 5.955 (0.2339 – 0.2344)
Valve stem end deflection	IN	Limit	mm (in)	0.14 (0.006)
	EX	Limit	mm (in)	0.18 (0.007)
Valve stem runout	IN,EX	Limit	mm (in)	0.05 (0.002)
Valve head radial runout	IN,EX	Limit	mm (in)	0.08 (0.003)
Valve head thickness	IN	STD	mm (in)	1.0 (0.04)
		Limit	mm (in)	0.7 (0.03)
	EX	STD	mm (in)	1.20 (0.05)
		Limit	mm (in)	0.7 (0.03)
Valve seat contact width	IN	STD	mm (in)	1.1 – 1.3 (0.04 – 0.05)
	EX	STD	mm (in)	1.1 – 1.3 (0.04 – 0.05)
Valve spring free length		STD	mm (in)	42.7 (1.68)
		Limit	mm (in)	41.0 (1.61)
Valve spring tension		STD	N (kg, lbs)	167 – 193 (16.7 – 19.3, 36.8 – 42.5) for 32.6 mm (1.28 in)
		Limit	N (kg, lbs)	151 (15.1, 33.3) for 32.6 mm (1.28 in)
Valve spring squareness		Limit	mm (in)	2.0 (0.08)

1-12 GENERAL INFORMATION

Item	Unit	Data	
		DF90T	DF115T

CYLINDER / PISTON / PISTON RING

Cylinder distortion	Limit	mm (in)	0.05 (0.002)
Piston to cylinder clearance	STD	mm (in)	0.020 – 0.040 (0.0008 – 0.0016)
	Limit	mm (in)	0.100 (0.0039)
Cylinder bore	STD	mm (in)	84.000 – 84.020 (3.3071 – 3.3079)
Cylinder measuring position		mm (in)	50 (2.0) from cylinder top surface
Piston skirt diameter	STD	mm (in)	83.970 – 83.990 (3.3059 – 3.3067)
Piston measuring position		mm (in)	26.5 (1.04) from piston skirt end.
Cylinder bore wear	Limit	mm (in)	0.10 (0.039)
Piston ring end gap	1st	STD	0.20 – 0.35 (0.008 – 0.014)
		Limit	0.70 (0.028)
	2nd	STD	0.35 – 0.50 (0.014 – 0.020)
		Limit	1.00 (0.039)
Piston ring free end gap	1st	STD	Approx. 11.3 (0.44)
		Limit	9.0 (0.354)
	2nd	STD	Approx. 11.0 (0.43)
		Limit	8.8 (0.347)
Piston ring to groove clearance	1st	STD	0.030 – 0.070 (0.0012 – 0.0028)
		Limit	0.12 (0.005)
	2nd	STD	0.020 – 0.060 (0.0008 – 0.0024)
		Limit	0.10 (0.004)
Piston ring groove width	1st	STD	1.22 – 1.24 (0.048 – 0.049)
	2nd	STD	1.51 – 1.53 (0.059 – 0.060)
	Oil	STD	2.51 – 2.53 (0.099 – 0.100)
Piston ring thickness	1st	STD	1.17 – 1.19 (0.046 – 0.047)
	2nd	STD	1.47 – 1.49 (0.058 – 0.059)
Pin clearance in piston pin hole	STD	mm (in)	0.006 – 0.017 (0.0002 – 0.0007)
	Limit	mm (in)	0.040 (0.0016)
Piston pin outside diameter	STD	mm (in)	20.997 – 21.000 (0.8267 – 0.8268)
	Limit	mm (in)	20.980 (0.8260)
Piston pin hole diameter	STD	mm (in)	21.006 – 21.014 (0.8270 – 0.8273)
	Limit	mm (in)	21.040 (0.8283)
Pin clearance in conrod small end	STD	mm (in)	0.003 – 0.014 (0.0001 – 0.0006)
	Limit	mm (in)	0.050 (0.0020)
Conrod small end bore	STD	mm (in)	21.003 – 21.011 (0.8269 – 0.8272)

Item	Unit	Data	
		DF90T	DF115T

CRANKSHAFT / CONROD

Conrod small end inside diameter	STD	mm (in)	21.003 – 21.011 (0.8269 – 0.8272)
Conrod big end oil clearance	STD	mm (in)	0.020 – 0.040 (0.0008 – 0.0016)
	Limit	mm (in)	0.065 (0.0026)
Conrod big end inside diameter	STD	mm (in)	47.000 – 47.018 (1.8504 – 1.8511)
Crank pin outside diameter	STD	mm (in)	43.982 – 44.000 (1.7316 – 1.7323)
Crank pin outside diameter difference (out of round and aper)	Limit	mm (in)	0.010 (0.0004)
Conrod bearing thickness	STD	mm (in)	1.484 – 1.502 (0.0584 – 0.0591)
Conrod big end side clearance	STD	mm (in)	0.100 – 0.250 (0.0039 – 0.0098)
	Limit	mm (in)	0.350 (0.0138)
Conrod big end width	STD	mm (in)	21.950 – 22.000 (0.8642 – 0.8661)
Crank pin width	STD	mm (in)	22.100 – 22.200 (0.8700 – 0.8740)
Crankshaft center journal runout	Limit	mm (in)	0.04 (0.002)
Crankshaft journal oil clearance	STD	mm (in)	0.020 – 0.040 (0.0008 – 0.0016)
	Limit	mm (in)	0.065 (0.0026)
Crankcase bearing holder inside diameter	STD	mm (in)	62.000 – 62.018 (2.4409 – 2.4417)
Crankshaft journal outside diameter	STD	mm (in)	57.994 – 58.012 (2.2832 – 2.2839)
Crankshaft journal outside diameter difference (out of round and taper)	Limit	mm (in)	0.010 (0.0004)
Crankshaft bearing thickness	STD	mm (in)	1.990 – 2.006 (0.0783 – 0.0790)
Crankshaft thrust play	STD	mm (in)	0.11 – 0.31 (0.004 – 0.012)
	Limit	mm (in)	0.35 (0.014)
Crankshaft thrust bearing thickness	STD	mm (in)	2.425 – 2.475 (0.0955 – 0.0974)

1-14 GENERAL INFORMATION

Item	Unit	Data	
		DF90T	DF115T

ELECTRICAL

Ignition timing	Degrees at r/min	BTDC 1° – BTDC 44°	BTDC 3° – BTDC 44°
Over revolution limiter	r/min	6500	
CKP sensor resistance	Ω at 20°C	168 – 252	
CMP sensor resistance	Ω at 20°C	—	
Ignition coil resistance	Primary	Ω at 20°C	1.9 – 2.5
	Secondary	k Ω at 20°C	No.2–No.3 : 18–34 (including H.T.cord and spark plug cap) No.1–No.4 : 19–36 (including H.T.cord and spark plug cap)
High tension cord resistance	k Ω /m at 20°C	Approx.16	
Battery charge coil resistance	Ω at 20°C	0.16 – 0.24	
Battery charge coil output (12V)	Watt	480	
Standard spark plug	Type	NGK	BKR6E
	Gap	mm (in)	0.7 – 0.8 (0.028 – 0.031)
Fuse amp. rating	A	Main fuse : 60 Sub fuse : 30	
Recommended battery capacity (12V)	Ah (kC)	100 (360) or larger	
Fuel injector resistance	Ω at 20°C	11.0 – 16.5	
IAC valve resistance	Ω at 20°C	8 – 12	
IAT sensor / Cylinder temp. sensor / Ex- mani. temp. sensor (Thermistor characteristic)	k Ω at 25°C	1.8 – 2.3	
ECM main relay resistance	Ω at 20°C	80 – 120	
Starter relay coil resistance	Ω at 20°C	80 – 120	
PTT motor relay coil resistance	Ω at 20°C	3.0 – 4.5	

STARTER MOTOR







Max. continuous time of use	Sec	30	
Motor output	kW	1.4	
Brush length	STD	mm (in)	16.0 (0.63)
	Limit	mm (in)	12.0 (0.47)
Commutator undercut	STD	mm (in)	0.5 – 0.8 (0.02 – 0.03)
	Limit	mm (in)	0.2 (0.01)
Commutator outside diameter	STD	mm (in)	29.0 (1.14)
	Limit	mm (in)	28.0 (1.10)
Commutator outside diameter difference	STD	mm (in)	0.05 (0.002)
	Limit	mm (in)	0.40 (0.016)

PTT MOTOR

Brush length	STD	mm (in.)	9.8 (0.39)
	Limit	mm (in.)	5.5 (0.22)
Commutator outside diameter	STD	mm (in.)	22.0 (0.87)
	Limit	mm (in.)	21.0 (0.83)

SELF-DIAGNOSTIC SYSTEM INDICATION

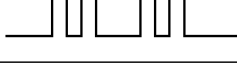
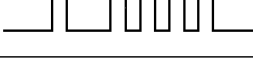
When the abnormality occurs in a signal from sensor, switch, etc., the "CHECK ENGINE" lamp on the monitor-tachometer flashes (lights intermittently) according to the each code pattern with buzzer sounding.

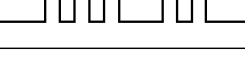
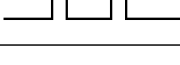
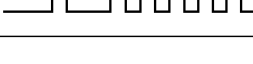
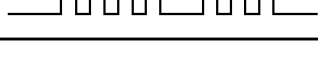
PRIORITY *	FAILED ITEM	CODE	LAMP FLASHING PATTERN	FAIL-SAFE SYSTEM ACTIVATING
1	MAP sensor 1	3 - 4	on  off	YES
2	CKP sensor	4 - 2	on  off	YES
3	IAC valve / By-pass air screw adjustment	3 - 1	on  off	NO
4	CMP sensor	2 - 4	on  off	YES
5	CTP switch	2 - 2	on  off	NO
6	Cylinder temp. sensor	1 - 4	on  off	YES
7	IAT sensor	2 - 3	on  off	YES
8	MAP sensor 2 (Pressure detect passage)	3 - 2	on  off	NO
9	Rectifier & regulator (Over-charging)	1 - 1	on  off	NO
10	Exhaust manifold temp. sensor	1 - 5	on  off	YES
11	Fuel injector	4 - 3	on  off	NO

* If more than two items fail at once, the self-diagnostic indication appears according to priority order. The indication repeats three times.

TIGHTENING TORQUE

Tightening Torque – Important Fasteners

ITEM	THREAD DIAMETER	TIGHTENING TORQUE			
		N · m	kg-m	lb.-ft	
Cylinder head cover bolt	6 mm	11	1.1	8.0	
Cylinder head bolt	8 mm	23	2.3	16.5	
	10 mm	70	7.0	50.5	
Crankcase bolt	8 mm	25	2.5	18.0	
	10 mm	56	5.6	40.5	
Conrod cap nut	8 mm	35	3.5	25.5	
Camshaft housing bolt	6 mm	11	1.1	8.0	
Camshaft timing sprocket bolt	10 mm	78	7.8	56.5	
Timing chain guide bolt	6 mm	10	1.0	7.0	
Intake manifold bolt / nut	8 mm	23	2.3	16.5	
Oil pressure switch	—	13	1.3	9.5	
Fuel delivery pipe bolt	8 mm	23	2.3	16.5	
Fuel delivery pipe plug / union bolt	Upper	12 mm	35	3.5	25.5
	Lower	12 mm	35	3.5	25.5
Fuel return pipe bolt	8 mm	23	2.3	16.5	
Low pressure fuel pump bolt	6 mm	10	1.0	7.0	
Thermostat cover bolt	6 mm	10	1.0	7.0	
Flywheel bolt	16 mm	245	24.5	177.0	
Starter motor mounting bolt	8 mm	23	2.3	16.5	
	10 mm	50	5.0	36.0	
Engine oil filter	—	14	1.4	10.0	
Engine oil drain plug	12 mm	13	1.3	9.5	
Power unit mounting bolt	8 mm	23	2.3	16.5	
	10 mm	50	5.0	36.0	
Driveshaft housing bolt	10 mm	50	5.0	36.0	
Upper mount nut	Front	12 mm	85	8.5	61.5
	Rear	12 mm	80	8.0	58.0
Upper mount cover bolt	10 mm	50	5.0	36.0	
Lower mount bolt / nut	12 mm	60	6.0	43.0	
Clamp bracket shaft nut	22 mm	43	4.3	31.0	
Water pump case bolt	8 mm	20	2.0	14.5	
Gearcase bolt	10 mm	55	5.5	40.0	
Propeller shaft bearing housing bolt	8 mm	20	2.0	14.5	
Pinion nut	14 mm	100	10.0	72.5	
Propeller nut	18 mm	55	5.5	40.0	





Tightening torque – general bolt

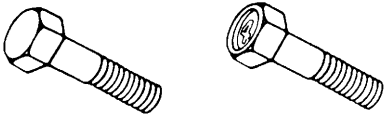
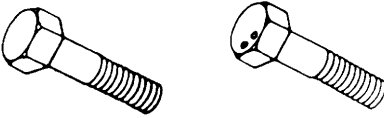
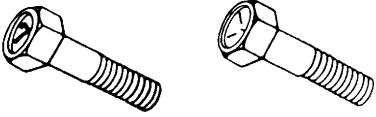



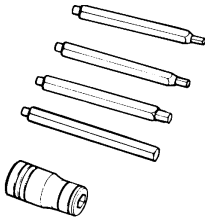
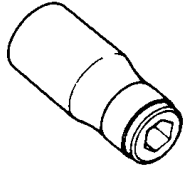

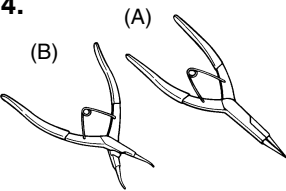
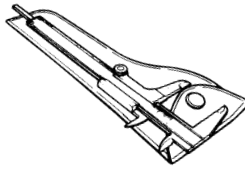
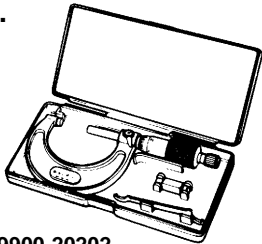
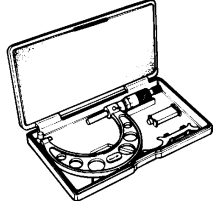
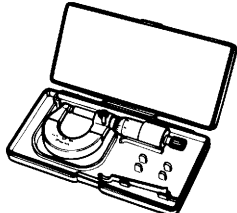
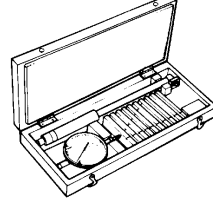
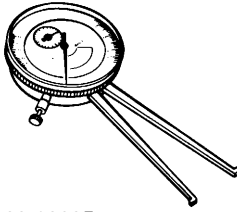
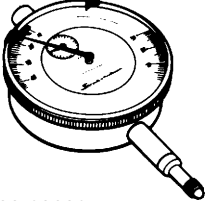
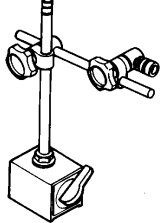
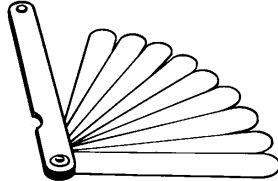
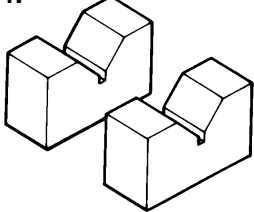

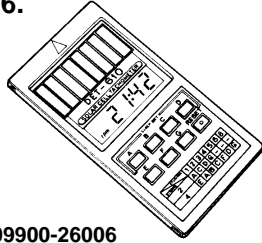
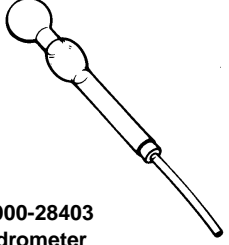
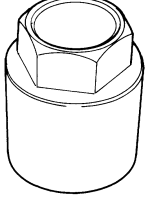
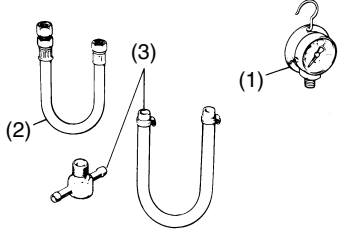
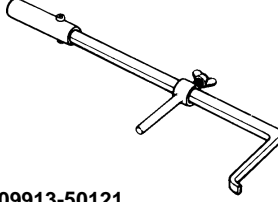
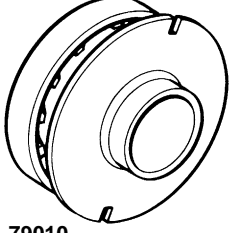
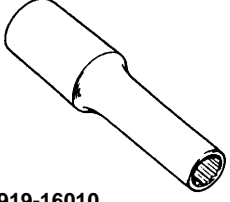
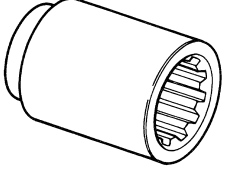
NOTE:

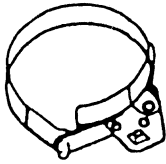
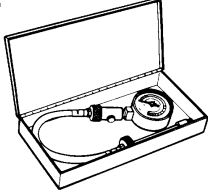
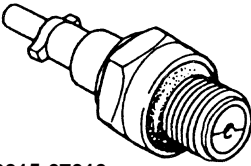
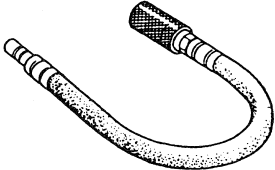
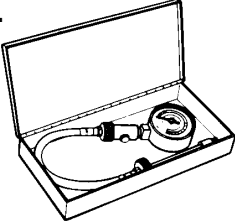
These values are only applicable when torque for a general bolt is not listed in the “Important Fasteners” table.

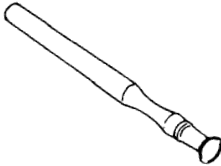
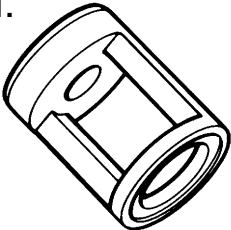
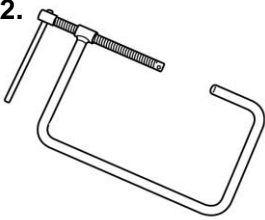
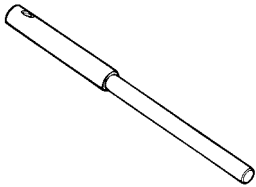
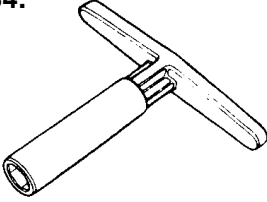

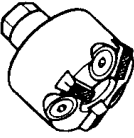
TYPE OF BOLT	THREAD DIAMETER	TIGHTENING TORQUE		
		N · m	kg-m	lb-ft
 (Conventional or “4” marked bolt)	5 mm	2 – 4	0.2 – 0.4	1.5 – 3.0
	6 mm	4 – 7	0.4 – 0.7	3.0 – 5.0
	8 mm	10 – 16	1.0 – 1.6	7.0 – 11.5
	10 mm	22 – 35	2.3 – 3.5	16.0 – 25.5
 (Stainless steel bolt)	5 mm	2 – 4	0.2 – 0.4	1.5 – 3.0
	6 mm	6 – 10	0.6 – 1.0	4.5 – 7.0
	8 mm	15 – 20	1.5 – 2.0	11.0 – 14.5
	10 mm	34 – 41	3.4 – 4.1	24.5 – 29.5
 (7 marked or 3 marked bolt)	5 mm	3 – 6	0.3 – 0.6	2.0 – 4.5
	6 mm	8 – 12	0.8 – 1.2	6.0 – 8.5
	8 mm	18 – 28	1.8 – 2.8	13.0 – 20.0
	10 mm	40 – 60	4.0 – 6.0	29.0 – 43.5

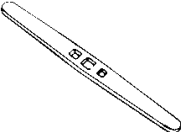
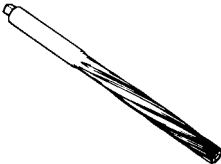
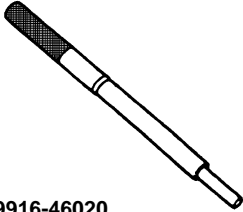
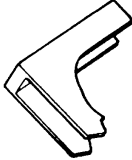
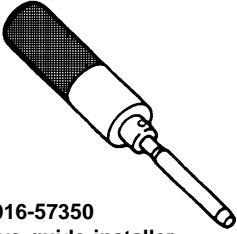
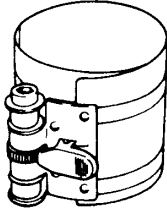
SPECIAL TOOLS

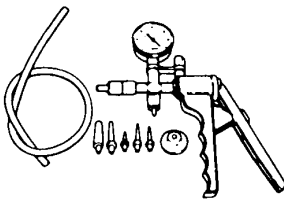
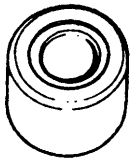
<p>1.</p>  <p>09900-00410 Hexagon wrench set</p>	<p>2.</p>  <p>09900-00411 Hexagon socket (included in 09900-00410)</p>	<p>3.</p>  <p>09900-00413 (5 mm) 09900-00414 (6 mm) Hexagon bit (included in 09900-00410)</p>	<p>4.</p>  <p>(A) (B)</p> <p>(A) 09900-06107 (B) 09900-06108 Snap ring pliers</p>
<p>5.</p>  <p>09900-20101 (150 mm) 09900-20102 (200 mm) Vernier calipers</p>	<p>6.</p>  <p>09900-20202 Micrometer (25 – 50 mm)</p>	<p>7.</p>  <p>09900-20203 (50 – 75 mm) 09900-20204 (75 – 100 mm) Micrometer</p>	<p>8.</p>  <p>09900-20205 Micrometer (0 – 25 mm)</p>
<p>9.</p>  <p>09900-20508 Cylinder gauge set</p>	<p>10.</p>  <p>09900-20605 Dial calipers (10 – 34 mm)</p>	<p>11.</p>  <p>09900-20602 Dial gauge</p>	<p>12.</p>  <p>09900-20701 Magnetic stand</p>
<p>13.</p>  <p>09900-20803 Thickness gauge</p>	<p>14.</p>  <p>09900-21304 Steel "V" block set</p>	<p>15.</p>  <p>09900-22302 (0.051 – 0.125 mm) 09900-22301 (0.025 – 0.076 mm) Plastigauge</p>	<p>16.</p>  <p>09900-26006 Engine tachometer</p>
<p>17.</p>  <p>09900-28403 Hydrometer</p>	<p>18.</p>  <p>09911-49910 Crankshaft holder</p>	<p>19.</p>  <p>09912-58413 Fuel pressure gauge set</p> <p>(1) 09912-58442 Fuel pressure gauge (2) 09912-58432 Fuel pressure hose (3) 09912-58490 3-way joint & hose</p>	
<p>20.</p>  <p>09913-50121 Oil seal remover</p>	<p>21.</p>  <p>09914-79010 Test wheel</p>	<p>22.</p>  <p>09919-16010 Deep socket wrench</p>	<p>23.</p>  <p>09921-29410 Driveshaft holder</p>

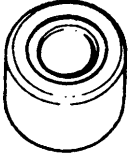
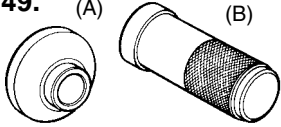
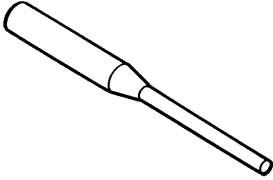
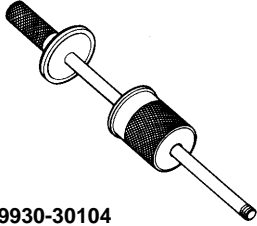
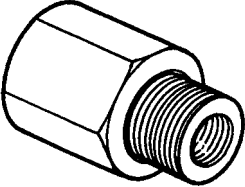
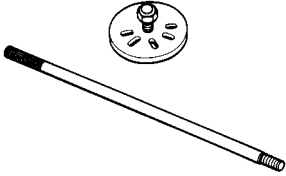
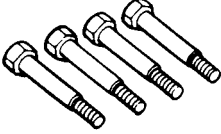
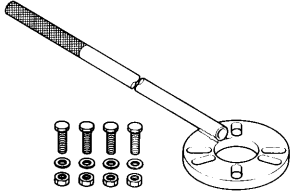
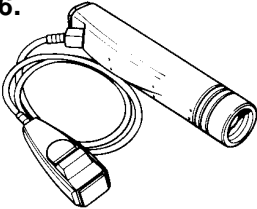
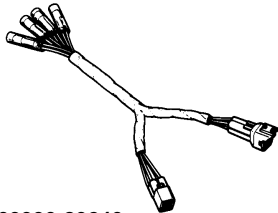
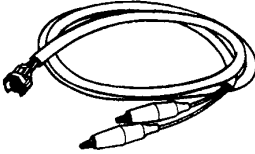
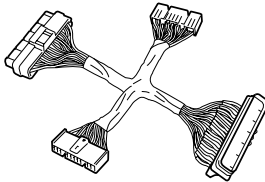
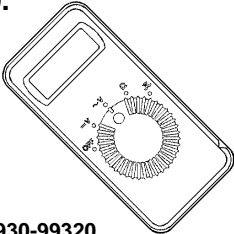
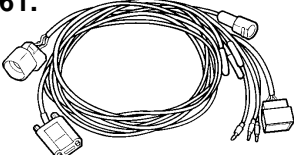
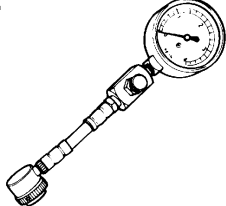
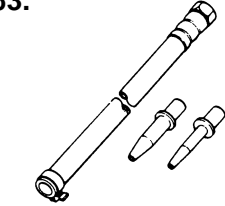
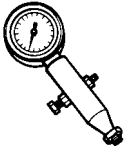
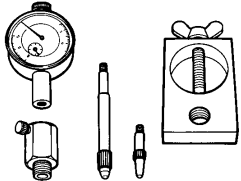
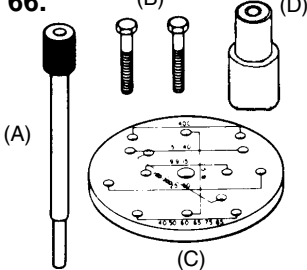
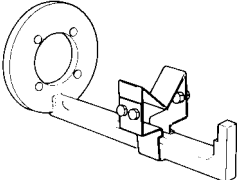
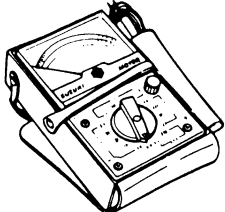
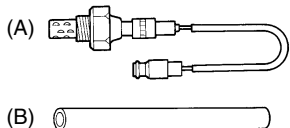
<p>24.</p>  <p>09915-47330 Oil filter wrench</p>	<p>25.</p>  <p>09915-64512 Compression gauge</p>	<p>26.</p>  <p>09915-67010 Compression gauge hose attachment</p>	<p>27.</p>  <p>09915-64530 Compression gauge hose</p>
<p>28.</p>  <p>09915-77311 Oil pressure gauge</p>	<p>29.</p>  <p>09915-78211 Oil pressure gauge adapter</p>	<p>30.</p>  <p>09916-10911 Valve lapper</p>	<p>31.</p>  <p>09916-14910 Valve lifter attachment</p>
<p>32.</p>  <p>09916-19030 Valve lifter</p>	<p>33.</p>  <p>Solid pilot (Neway. N-120-6.0)</p>	<p>34.</p>  <p>09916-54910 Handle (N-505)</p>	<p>35.</p>  <p>09916-22420 Valve seat cutter (60°) (Neway 114)</p>
<p>36.</p>  <p>09916-20620 Valve seat cutter (45°) (Neway 122)</p>	<p>37.</p>  <p>09916-20610 Valve seat cutter (15°) (Neway 121)</p>	<p>38.</p>  <p>09916-37810 Valve guide reamer (φ 6 mm)</p>	<p>39.</p>  <p>09916-34542 Valve guide reamer handle</p>
<p>40.</p>  <p>09916-38210 Valve guide reamer (φ 11 mm)</p>	<p>41.</p>  <p>09916-46020 Valve guide remover</p>	<p>42.</p>  <p>09916-49040 Tappet holder</p>	<p>43.</p>  <p>09916-57350 Valve guide installer</p>
<p>44.</p>  <p>09916-77310 Piston ring compressor</p>	<p>45.</p>  <p>09916-84511 Tweezers</p>	<p>46.</p>  <p>09917-47011 Vacuum pump gauge</p>	<p>47.</p>  <p>09917-87810 Valve guide installer attachment</p>

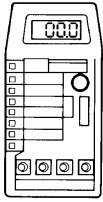

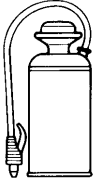



<p>48.</p>  <p>09917-98221 Valve guide stem seal installer attachment</p>	<p>49. (A) (B)</p>  <p>(A) 09922-59410 Propeller shaft housing installer (B) 09922-59420 Housing installer handle</p>	<p>50.</p>  <p>09922-89810 Shift lock pin remover</p>	<p>51.</p>  <p>09930-30104 Sliding hammer</p>
<p>52.</p>  <p>09930-30161 Propeller shaft remover</p>	<p>53.</p>  <p>09930-39411 Flywheel rotor remover</p>	<p>54.</p>  <p>09930-39420 Rotor remover bolt</p>	<p>55.</p>  <p>09930-48720 Flywheel holder</p>
<p>56.</p>  <p>09930-76420 Timing light</p>	<p>57.</p>  <p>09930-89240 4-pin connector test cord</p>	<p>58.</p>  <p>09930-89260 Injector test cord A</p>	<p>59.</p>  <p>09930-89950 44-pin test cord</p>
<p>60.</p>  <p>09930-99320 Digital tester</p>	<p>61.</p>  <p>09932-79910 Diagnostic harness 09932-89910 SDS adapter</p>	<p>62.</p>  <p>09940-44121 Air pressure gauge</p>	<p>63.</p>  <p>09940-44130 Attachment</p>
<p>64.</p>  <p>09950-69512 Gearcase oil leakage tester</p>	<p>65.</p>  <p>09951-09511 Gear adjusting gauge</p>	<p>66. (B) (D)</p>  <p>(A) (B) (C) (D)</p> <p>Pinion bearing installer and remover (A) 09951-59910 Pinion bearing installer shaft (B) 01500-08403 Bolt (C) 09951-39914 Pinion bearing plate (D) 09951-19421 Attachment</p>	
<p>67.</p>  <p>09951-09010 Shimming gauge</p>	<p>68.</p>  <p>09900-25002 Pocket tester</p>	<p>69. (A) (B)</p>  <p>(A) 18213-74F00 O₂ sensor (B) 18498-99E70 Protector</p>	<p>70.</p>

<p>71.</p>  <p>99954-53008-820* Digital voltmeter</p>	<p>72.</p>  <p>99954-53873* Stevens CD-77 Peak reading voltmeter</p>	<p>73.</p>  <p>99954-53883* Gear oil filler</p>
--	---	---

NOTE:

* Marked part No. is in U.S. market only.

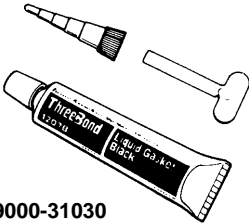
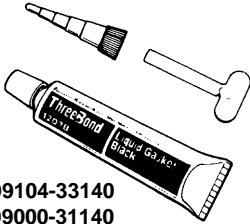
MATERIALS REQUIRED

<p>SUZUKI OUTBOARD MOTOR GEAR OIL</p>  <p>99000-22540 (400 ml x 24 pcs.)</p>	<p>SUZUKI SUPER GREASE "A"</p>  <p>*99000-25030 99000-25010 (500 g)</p>	<p>WATER RESISTANT GREASE</p>  <p>99000-25160 (250 g)</p>	<p>SUZUKI SILICONE SEAL</p>  <p>99000-31120 (50 g)</p>
<p>SUZUKI BOND "1104"</p>  <p>99000-31030 (100 g)</p>	<p>SUZUKI BOND "1207B"</p>  <p>* 99104-33140 99000-31140 (100 g)</p>	<p>THREAD LOCK "1342"</p>  <p>99000-32050 (50 g)</p>	<p>THREAD LOCK SUPER "1333B"</p>  <p>99000-32020 (50 g)</p>
<p>4-Stroke Motor Oil</p> <p>API : SE, SF, SG, SH, SJ SAE : 10W-40</p>			

NOTE:

* Marked part No. is in U.S. market only.

PERIODIC MAINTENANCE

CONTENTS

PERIODIC MAINTENANCE SCHEDULE	2-2
PERIODIC MAINTENANCE CHART	2-2
MAINTENANCE AND TUNE-UP PROCEDURES	2-3
ENGINE OIL / ENGINE OIL FILTER	2-3
GEAR OIL	2-6
LUBRICATION	2-7
SPARK PLUG	2-8
TAPPET CLEARANCE	2-9
IDLE SPEED	2-14
IGNITION TIMING	2-15
BREATHER AND FUEL LINE	2-16
LOW PRESSURE FUEL FILTER	2-16
HIGH PRESSURE FUEL FILTER	2-17
WATER PUMP / WATER PUMP IMPELLER	2-17
PROPELLER / NUT / COTTER PIN	2-17
ANODES AND BONDING WIRES	2-18
BATTERY	2-19
BOLT AND NUTS	2-20
FUEL MIXTURE CHECK (O₂ FEEDBACK)	2-20
OIL PRESSURE	2-21
CYLINDER COMPRESSION	2-23

PERIODIC MAINTENANCE SCHEDULE

The chart below lists the recommended intervals for all the required periodic service work necessary to keep the motor operating at peak performance and economy.

Maintenance intervals should be judged by number of hours or months, whichever comes first.

NOTE:

More frequent servicing should be performed on outboard motors that are used under severe conditions.

PERIODIC MAINTENANCE CHART

Item to be serviced \ Interval	Initial 20 hrs. or 1 month	Every 50 hrs. or 3 months	Every 100 hrs. or 6 months	Every 200 hrs. or 12 months
Spark plug	—	—	I	R
Breather Hose & Fuel line	I	I	I	I
	Replace every 2 years.			
Engine oil [NOTE]	R	—	R	R
Gear oil	R	—	R	R
Lubrication	—	I	I	I
Anodes & Bonding wires	—	I	I	I
Battery	—	I	I	I
Fuel mixture check (O ₂ feedback)	Perform every 2 years.			
Engine oil filter	R	—	—	R
Low pressure fuel filter	—	I	I	I
	Replace every 400 hours or 2 years.			
High pressure fuel filter	Replace every 1000 hours.			
Ignition timing	—	—	—	I
Idle Speed	I	—	—	I
Tappet clearance	I	—	—	I
Water pump	—	—	—	I
Water pump impeller	—	—	—	R
Propeller nut & pin	I	—	I	I
Bolt & Nuts	T	—	T	T

I : Inspect and clean, adjust, lubricate, or replace, if necessary T : Tighten R : Replace

NOTE:

OIL CHANGE REMINDER SYSTEM

- Refer to page 3-32 for function and operation.
- See page 2-5 for reset information.

MAINTENANCE AND TUNE-UP PROCEDURES

This section describes servicing procedures for each of periodic maintenance requirements.

ENGINE OIL / ENGINE OIL FILTER ENGINE OIL LEVEL CHECK

Inspect oil level before every use.

1. Place outboard motor upright on a level surface.
2. Remove motor cover.
3. Remove oil level dipstick and wipe it clean.
4. Insert it fully into dipstick hole, then remove it to check oil level.
5. Oil level should be between full level hole (Max.) and low level hole (Min.).

If level is low, add recommended oil to full level hole (Max.).

Recommended oil :

- 4 stroke motor oil
- API classification SE, SF, SG, SH, SJ.
- Viscosity rating SAE 10 W-40.

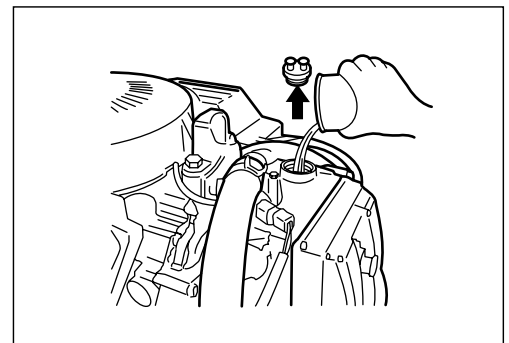
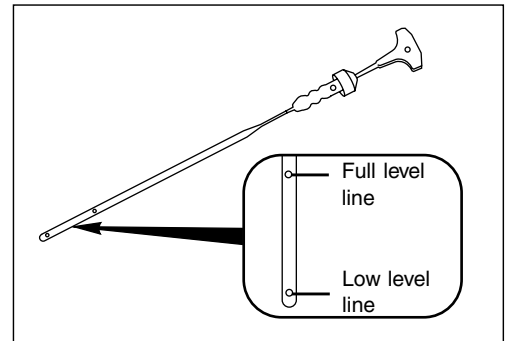
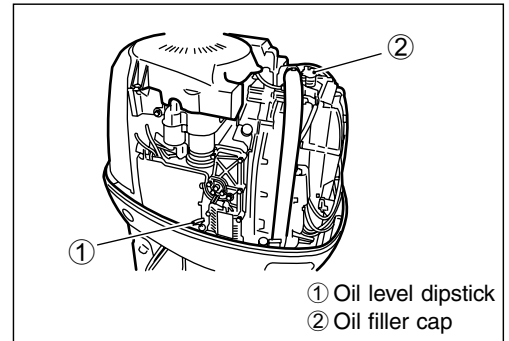

ENGINE OIL CHANGE / ENGINE OIL FILTER REPLACEMENT

ENGINE OIL

Change initially after 20 hours (1 month) and every 100 hours (6 months).

ENGINE OIL FILTER

Replace initially after 20 hours (1 month) and every 200 hours (12 months).

NOTE:

- Engine oil should be changed while engine is warm.
- When replacing engine oil filter, change engine oil at the same time.

1. Place outboard motor upright on a level surface.
2. Remove oil filler cap.
3. Place a container under engine oil drain plug.
4. Remove engine oil drain plug and gasket to drain engine oil.

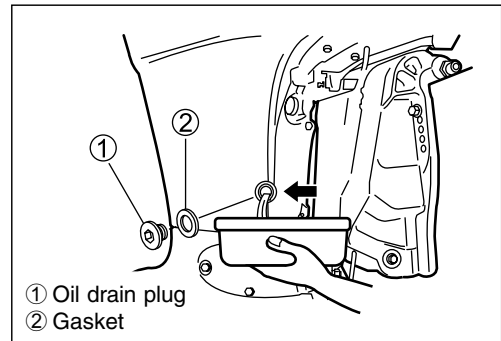
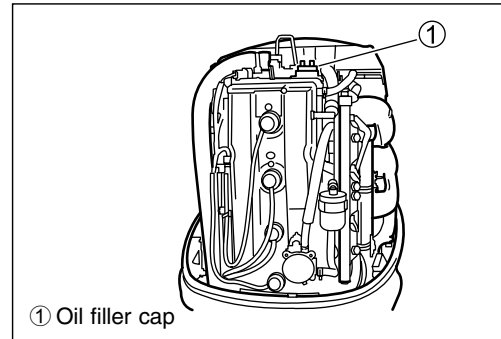

5. ENGINE OIL FILTER REPLACEMENT

NOTE:

For engine oil change only, go to step 6.

To replace engine oil filter :

- (1) Remove STBD side cover. (See page 7-2)
- (2) Using oil filter wrench to loosen the oil filter, then remove filter and O-ring.

 **09915-47330 : Oil filter wrench**

NOTE:

Before fitting new oil filter, be sure to oil O-ring.

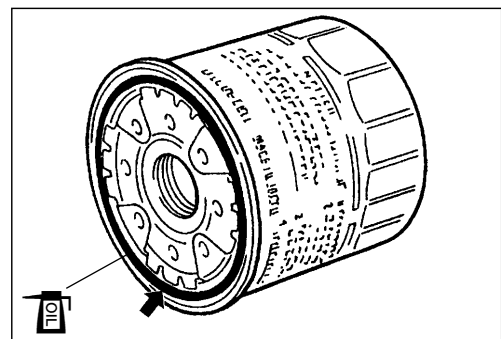
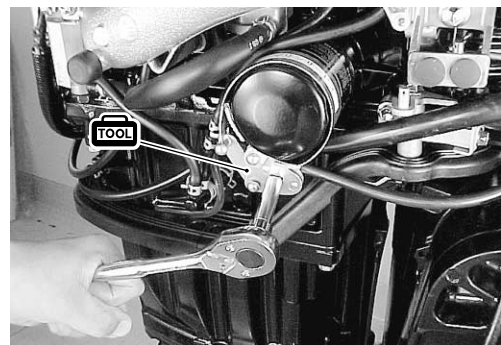

- (3) Screw new filter on by hand until filter O-ring contacts the mounting surface.
- (4) Tighten filter 3/4 turn from point of contact with mounting surface using an oil filter wrench.

 **Engine oil filter : 14 N·m (1.4 kg-m, 10.0 lb.-ft.), 3/4 turn.**

- (5) Install STBD side cover.

- 6. Install gasket and oil drain plug.
Tighten engine oil drain plug to specified torque.

 **Engine oil drain plug : 13 N·m (1.3 kg-m, 9.5 lb.-ft.)**

CAUTION

Do not re-use gasket once removed. Always use a new gasket.

- 7. Pour recommended engine oil into oil filler opening, then install oil filler cap.

Engine oil amounts

Oil change only : 5.5 L (5.8 / 4.8 US / Imp. qt)

Oil filter change : 5.7 L (6.0 / 5.0 US / Imp. qt)

- 8. To reset oil change reminder system's operation time to zero (cancellation) ;

- (1) Turn ignition key to "ON" position.
- (2) Pull out emergency stop switch plate ①.
- (3) Pull up emergency stop switch knob ② three times in seven seconds. A short beep will be heard if cancellation is successfully finished.
- (4) Turn ignition key to "OFF" position, then set emergency stop switch plate ① in original position.

NOTE:

See "OIL CHANGE REMINDER SYSTEM" section on page 3-32.

- 9. Start engine and allow it to run for several minutes at idle speed.

Check oil filter for oil leakage.

Turn off engine and wait for approx. two minutes, then re-check engine oil level.

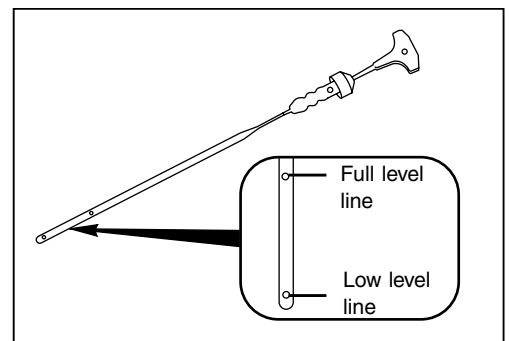
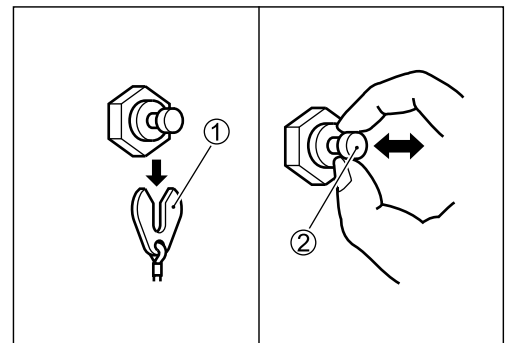
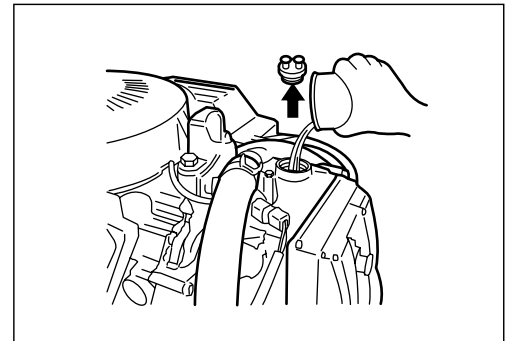
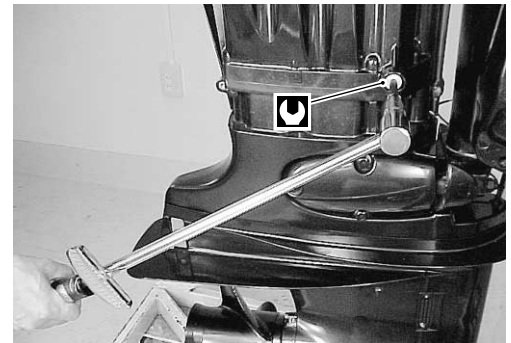

GEAR OIL

Change initially after 20 hours (1 month) and every 100 hours (6 months).

1. Place outboard motor upright on a level surface.
2. Place a container under lower unit.
3. Remove lower gear oil drain plug before gear oil level plug and drain gear oil.

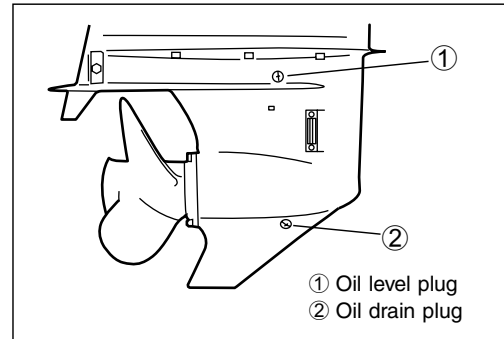

4. Fill with recommended gear oil through oil drain hole until oil just starts to flow out from oil level hole.

Gear oil amount : 1050 ml (35.5 / 37.0 US / Imp. oz)

Recommended oil :

**Suzuki Outboard Motor Gear Oil or SAE #90
Hypoid gear oil**

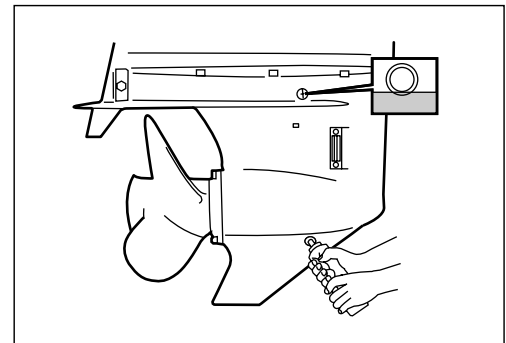

5. Install oil level plug before removing oil filler tube from drain hole.
6. Install oil drain plug.

CAUTION

Do not re-use gaskets once removed. Always use a new gasket.

NOTE:

To avoid insufficient injection of gear oil, check gear oil level 10 minutes after doing procedure in step 6. If oil level is low, slowly inject gear oil up to the correct level.

LUBRICATION

Inspect every 50 hours (3 months).

Apply Suzuki Water Resistant Grease to the following points.

 **99000-25160 : Water Resistant Grease**

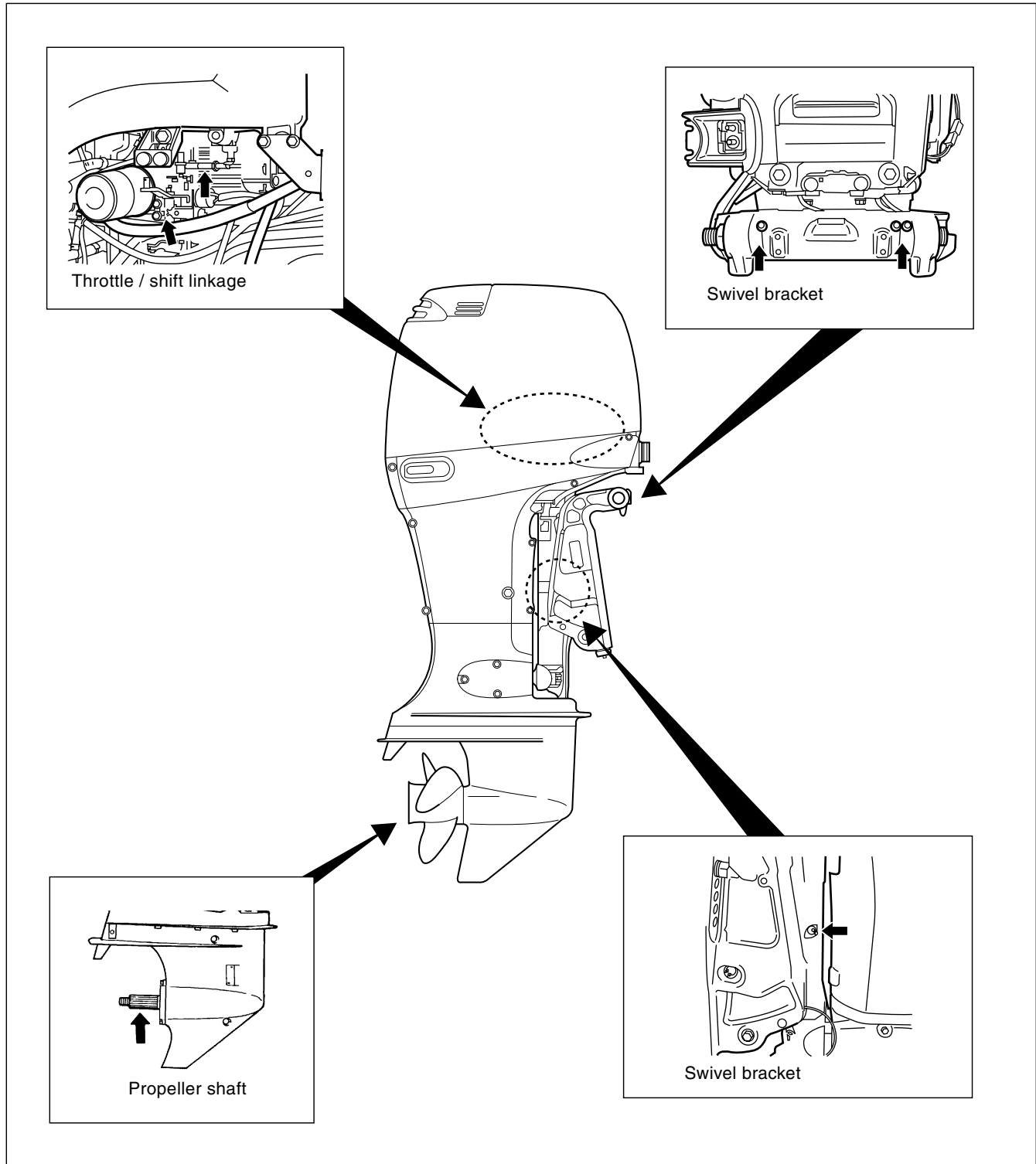

SPARK PLUG

- Inspect every 100 hours (6 months).
- Replace every 200 hours (12 months).

Standard spark plug : NGK BKR6E

CAUTION

Only resistor (R) type spark plugs must be used with this engine. Using a non-resistor spark plug will cause ignition and fuel injection system malfunctions.

CARBON DEPOSIT

Inspect for a carbon deposit on spark plug bases. If carbon is present, remove it with a spark plug cleaning machine or by carefully using a pointed tool.

SPARK PLUG GAP

Using thickness gauge, measure for spark plug gap. Adjust to within specified range if gap is out of specification.

Spark plug gap : 0.7 – 0.8 mm (0.028 – 0.031 in.)

 09900-20803 : Thickness gauge

CONDITION OF ELECTRODE

Inspect electrode for a worn or burnt condition. If it is extremely worn or burnt, replace spark plug. Also, be sure to replace spark plug if it has a broken insulator, damaged thread, etc.

CAUTION

Confirm the thread size and reach when replacing the plug. If the reach is too short, carbon will be deposited on the threaded portion of the plug hole resulting in possible engine damage.

 Spark plug : 28 N·m (2.8 kg·m, 20.0 lb.-ft.)

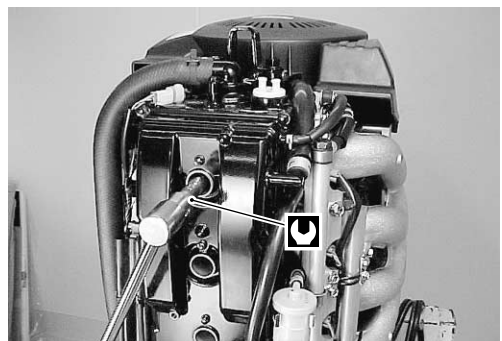
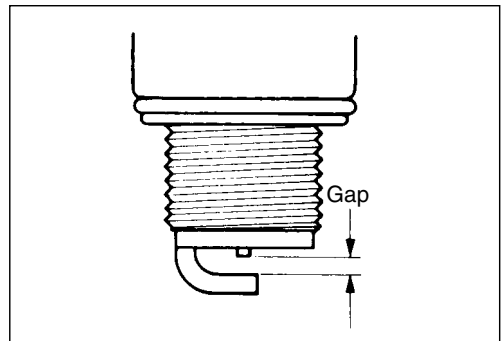
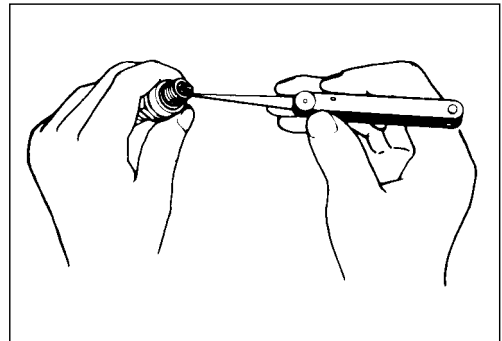
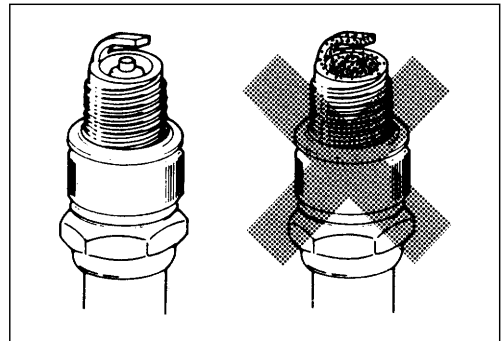
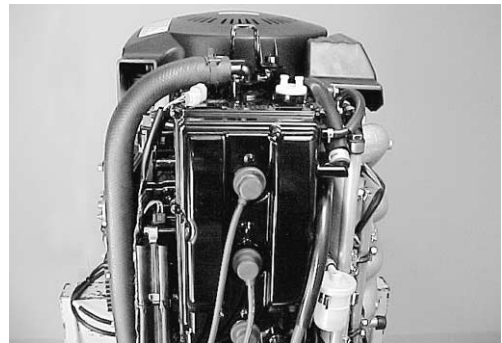

TAPPET CLEARANCE

Inspect initially after 20 hours (1 month) and every 200 hours (12 months).

The tappet clearance specification is the same for both intake and exhaust valves.

Too small a tappet clearance may reduce engine power, too large a tappet clearance increases valve noise and hastens valve and seat wear.

When the tappets are set to the specified clearance, the engine will run without excessive noise from the valve mechanism and will deliver full power. In this engine, the tappet clearance is increased or decreased by replacing the shim disc, made of a special wear resistant material, fitted to the top of the tappet.

The shim discs are easy to remove and refit.

Tappet clearance adjustment should be checked and adjusted :

- at time of periodic inspection
- when valve mechanism is serviced
- when camshafts are disturbed by removing them for inspection

CHECKING AND ADJUSTING TAPPET CLEARANCE

1. Remove following parts :
 - Engine side covers (see page 7-2)
 - Flywheel cover
 - Spark plugs

2. Remove breather hose ① and evaporation hose ② from cylinder head cover.

3. Remove fuel hose ③ and ④ from low pressure fuel pump.

4. Remove fifteen (15) bolts securing cylinder head cover ⑤ to cylinder head and remove cylinder head cover.

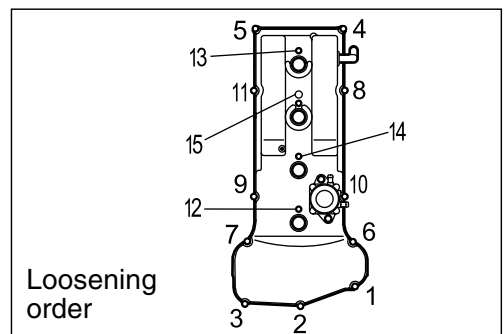
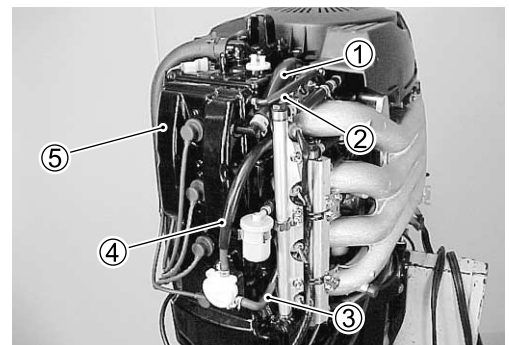
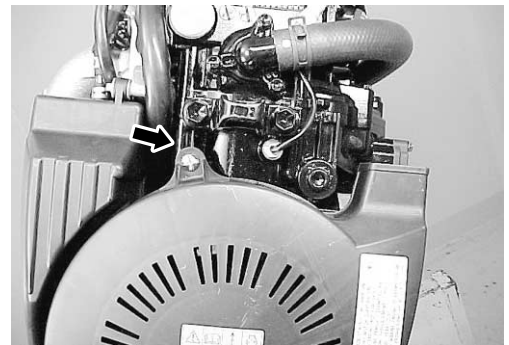

2-10 PERIODIC MAINTENANCE

5. Rotate crankshaft counterclockwise to bring cam nose vertical to shim surface.
6. Measure tappet clearances by inserting thickness gauge between cam and shim surface.

Tappet clearance (cold engine condition) :

IN. : 0.23 – 0.27 mm (0.009 – 0.011 in.)

EX. : 0.23 – 0.27 mm (0.009 – 0.011 in.)

 **09900-20803 : Thickness gauge**

CAUTION

**This is a left hand (LH) rotation powerhead.
Rotate crankshaft counterclockwise to prevent water
pump impeller damage.**

NOTE:

- Rotate crankshaft and measure clearance for each tappet respectively by bringing cam nose vertical to shim surface.
 - All tappet clearances can be measured during two turns of crankshaft.
7. If out of specification, adjust tappet clearance by changing shim.

ADJUSTMENT

Tappet clearances are adjusted by replacing tappet shim.

1. Close valve and turn tappet cut-away toward inside as shown in figure.
2. Rotate crankshaft to open (lift up) valve and then remove camshaft housing bolts where shim is to be replaced.
3. Install special tool with camshaft housing bolts as shown in figure.

 **09916-49040 : Tappet holder**

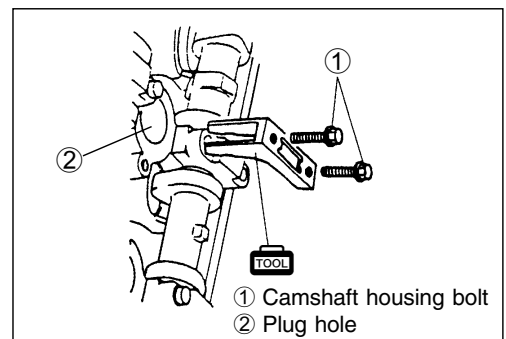
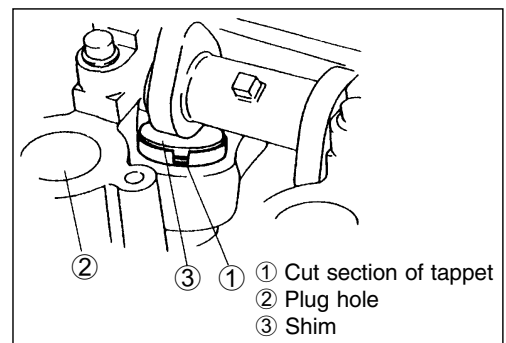
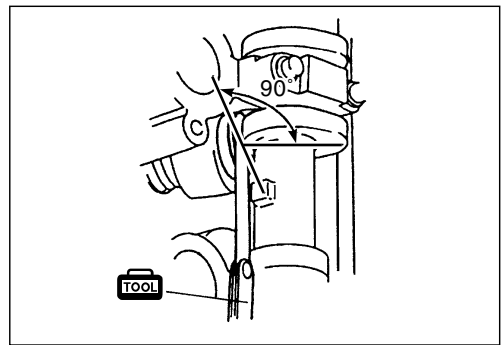

- Rotate top of cam 90 degree clockwise and remove shim from cut-away at tappet.
(Two tappets can be adjusted at the same time)

CAUTION

- Do not put your finger between camshaft and tappet while the tappet is being held with the tappet holder.
- Use a magnet to remove and install shim.
- When installing shim, identification mark on the shim should face towards tappet side.

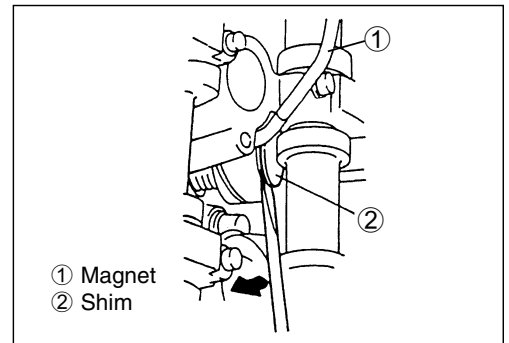

- After removing shim, measure thickness of original shim and determine correct thickness of shim for proper tappet clearance as calculated by following formula.

TOOL 09900-20205 : Micrometer

$$A = B + (C - 0.25 \text{ mm})$$

A : Correct thickness of shim for proper tappet clearance (mm)

B : Thickness of original shim (mm)

C : Original tappet clearance (mm)

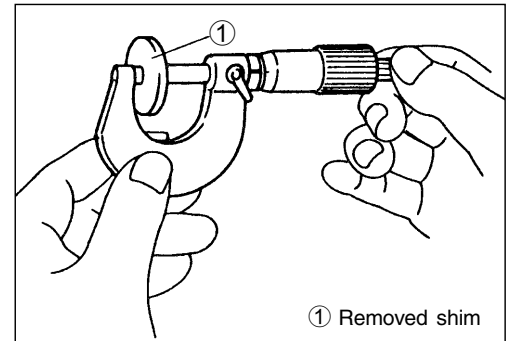

I.D No.	Thickness (mm)	I.D No.	Thickness (mm)	I.D No.	Thickness (mm)
218	2.18	248	2.48	278	2.78
220	2.20	250	2.50	280	2.80
223	2.23	253	2.53	283	2.83
225	2.25	255	2.55	285	2.85
228	2.28	258	2.58	288	2.88
230	2.30	260	2.60	290	2.90
233	2.33	263	2.63	293	2.93
235	2.35	265	2.65	295	2.95
238	2.38	268	2.68	298	2.98
240	2.40	270	2.70	300	3.00
243	2.43	273	2.73		
245	2.45	275	2.75		

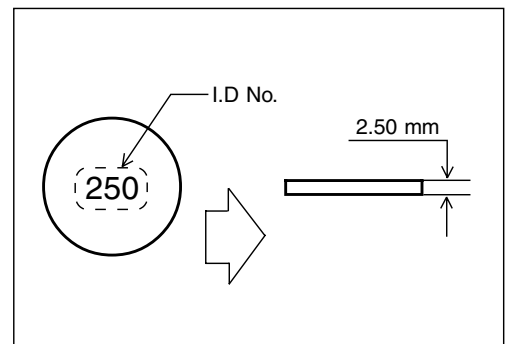

2-12 PERIODIC MAINTENANCE

6. Install shim. Identification number should face towards tappet.
7. Rotate crankshaft to be open (lift up) valve.
8. Remove tappet holder ① and tighten camshaft housing bolts to specified torque.

Camshaft housing bolt :

11 N·m (1.1 kg-m, 8.0 lb.-ft.)

9. Recheck tappet clearance.

NOTE:

After completing tappet clearance adjustment and securing camshaft housing bolts, inspect tappet clearance again.

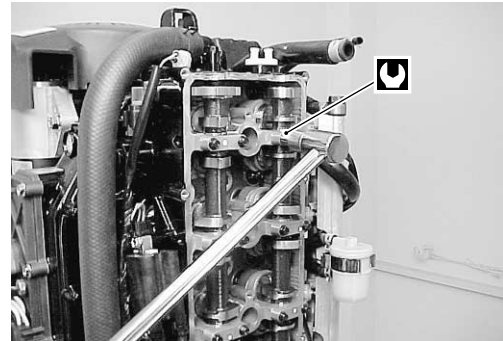
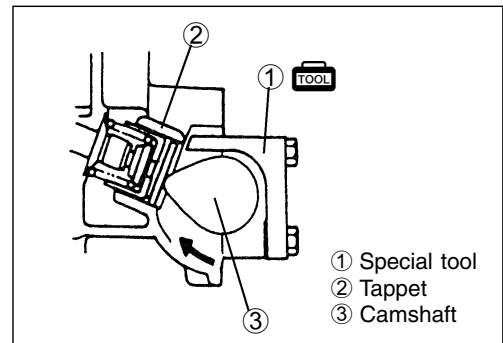

INSTALLATION

After checking and adjusting all tappet clearances, install cylinder head cover. Installation is reverse order of removal. (See page 6-10)

Cylinder head cover bolts :

11 N·m (1.1 kg-m, 7.0 lb.-ft.)

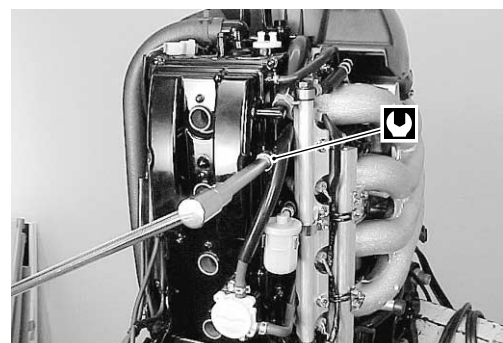
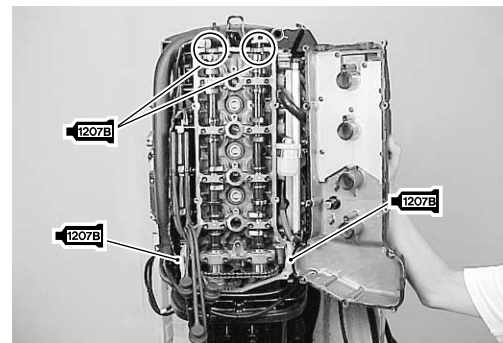

TAPPET SHIM SELECTION CHART

Shim I.D. No.	218	220	223	225	228	230	233	235	238	240	243	245	248	250	253	255	258	260	263	265	268	270	273	275	278	280	283	285	288	290	293	295	298	300
Present shim size (mm)																																		
Tappet clearance (mm)	2.18	2.20	2.23	2.25	2.28	2.30	2.33	2.35	2.38	2.40	2.43	2.45	2.48	2.50	2.53	2.55	2.58	2.60	2.63	2.65	2.68	2.70	2.73	2.75	2.78	2.80	2.83	2.85	2.88	2.90	2.93	2.95	2.98	3.00
0.00 – 0.04	/	/	/	/	/	/	/	/	/	/	220	223	225	228	230	233	235	238	240	243	245	248	250	253	255	258	260	263	265	268	270	273	275	278
0.05 – 0.09	/	/	/	/	/	/	/	/	220	223	225	228	230	233	235	238	240	243	245	248	250	253	255	258	260	263	265	268	270	273	275	278	280	283
0.10 – 0.14	/	/	/	/	/	220	223	225	228	230	233	235	238	240	243	245	248	250	253	255	258	260	263	265	268	270	273	275	278	280	283	285	288	
0.15 – 0.19	/	/	/	220	223	225	228	230	233	235	238	240	243	245	248	250	253	255	258	260	263	265	268	270	273	275	278	280	283	285	288	290	293	
0.20 – 0.22	/	220	223	225	228	230	233	235	240	240	245	245	250	250	255	255	260	260	263	265	270	270	273	278	280	280	283	285	290	290	293	295		
0.23 – 0.27	SPECIFIED CLEARANCE / NO. ADJUSTMENT REQUIRED																																	
0.28 – 0.32	223	225	228	230	233	235	238	240	243	245	248	250	253	255	258	260	263	265	268	270	273	275	278	280	283	285	288	290	293	295	298	300		
0.33 – 0.37	228	230	233	235	238	240	243	245	248	250	253	255	258	260	263	265	268	270	273	275	278	280	283	285	288	290	293	295	298	300				
0.38 – 0.42	233	235	238	240	243	245	248	250	253	255	258	260	263	265	268	270	273	275	278	280	283	285	288	290	293	295	298	300						
0.43 – 0.47	238	240	243	245	248	250	253	255	258	260	263	265	268	270	273	275	278	280	283	285	288	290	293	295	298	300								
0.48 – 0.52	243	245	248	250	253	255	258	260	263	265	268	270	273	275	278	280	283	285	288	290	293	295	298	300										
0.53 – 0.57	248	250	253	255	258	260	263	265	268	270	273	275	278	280	283	285	288	290	293	295	298	300												
0.58 – 0.62	253	255	258	260	263	265	268	270	273	275	278	280	283	285	288	290	293	295	298	300														
0.63 – 0.67	258	260	263	265	268	270	273	275	278	280	283	285	288	290	293	295	298	300																
0.68 – 0.72	263	265	268	270	273	275	278	280	283	285	288	290	293	295	298	300																		
0.73 – 0.77	268	270	273	275	278	280	283	285	288	290	293	295	298	300																				
0.78 – 0.82	273	275	278	280	283	285	288	290	293	295	298	300																						
0.83 – 0.87	278	280	283	285	288	290	293	295	298	300																								
0.88 – 0.92	283	285	288	290	293	295	298	300																										

1. Measure tappet clearance “Engine cold”.
2. Measure present shim size.
3. Match clearance in vertical column with present shim size in horizontal column.

[EXAMPLE]

Tappet clearance is — 0.35 mm
 Present shim size — 2.40 mm
 Shim size to be used — 2.50 mm

IDLE SPEED

Inspect initially after 20 hours (1 month) and every 200 hours (12 months).

NOTE:

- Before checking idle speed, engine should be allowed to warm up.
- Check and/or adjust idle speed after engine speed has stabilized.
- Before checking idle speed, check throttle link mechanism and throttle valve for smooth operation.

1. Start engine and allow to warm up.
2. Attach engine tachometer to the ignition high-tension cord.

 **09900-26006 : Engine tachometer**

3. Check engine speed.
Idle speed (in neutral gear) : 600 – 650 r/min.

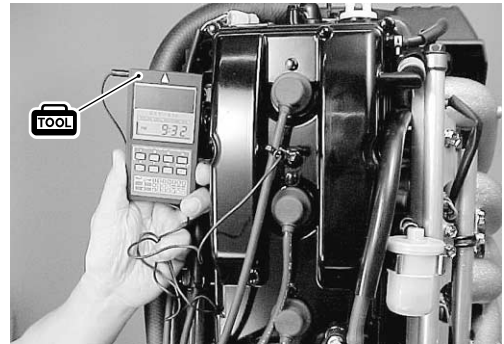

ADJUSTMENT :

If idle speed is out of specification, perform following adjustment procedure.

4. Check that CTP switch is in ON position.
5. To set the IAC valve duty to constant 15%, raise engine speed to 1000 r/min. or higher by turning the by-pass air screw and hold that speed for 10 seconds.

At this time, caution buzzer will sound to notify that IAC duty is in fixed mode.

- Turning air screw counterclockwise :**
Engine speed will increase.
- Turning air screw clockwise :**
Engine speed will decrease.

NOTE:

- While IAC valve duty is at fixed 15%, caution buzzer will sound for repeated 0.5 second with an interval of 3 seconds.
 - The 15% fixed mode of IAC valve duty will continue for 5 minutes and then it will be automatically cancelled.
6. During fixed mode of IAC valve duty, adjust engine speed to 625 ± 25 r/min. by turning by-pass air screw.

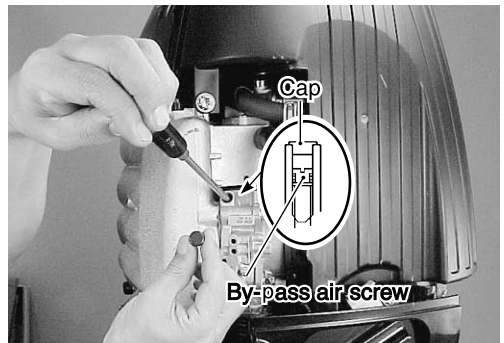

- Open warm-up lever to turn CTP switch off.

NOTE:

The fixed mode of IAC valve duty can be manually cancelled by turning CTP switch off.

- Close warm-up lever and then recheck engine speed.
It should now be stable at 600 – 650 r/min.

NOTE:

Idling / trolling speed of 600 – 650 r/min. is controlled by IAC (idle air control) system.

If engine speed does not return to specification, IAC passage (including the IAC hose) may be clogged or IAC system may not be operating correctly.

See “IDLE AIR CONTROL SYSTEM” section on page 3-21.

NOTE:

Trolling speed (in-gear idle speed) is same as idle speed.

IGNITION TIMING

Inspect every 200 hours (12 months).

NOTE:

Before checking ignition timing, make sure idle speed is adjusted within specification.

- Start engine and allow to warm up.
- Attach timing light cord to No.1 ignition high-tension cord.

-  **09930-76420 : Timing light**
- 09900-26006 : Engine tachometer**

- Check ignition timing while operating engine in neutral gear at 1000 r/min.

Ignition timing : Approx. BTDC 8° at 1000 r/min.



BREATHER AND FUEL LINE

- Inspect initially after 20 hours (1 month) and every 50 hours (3 months).
- Replace every 2 years.

If leakage, cracks, swelling or other damage is found, replace breather line and/or fuel line.

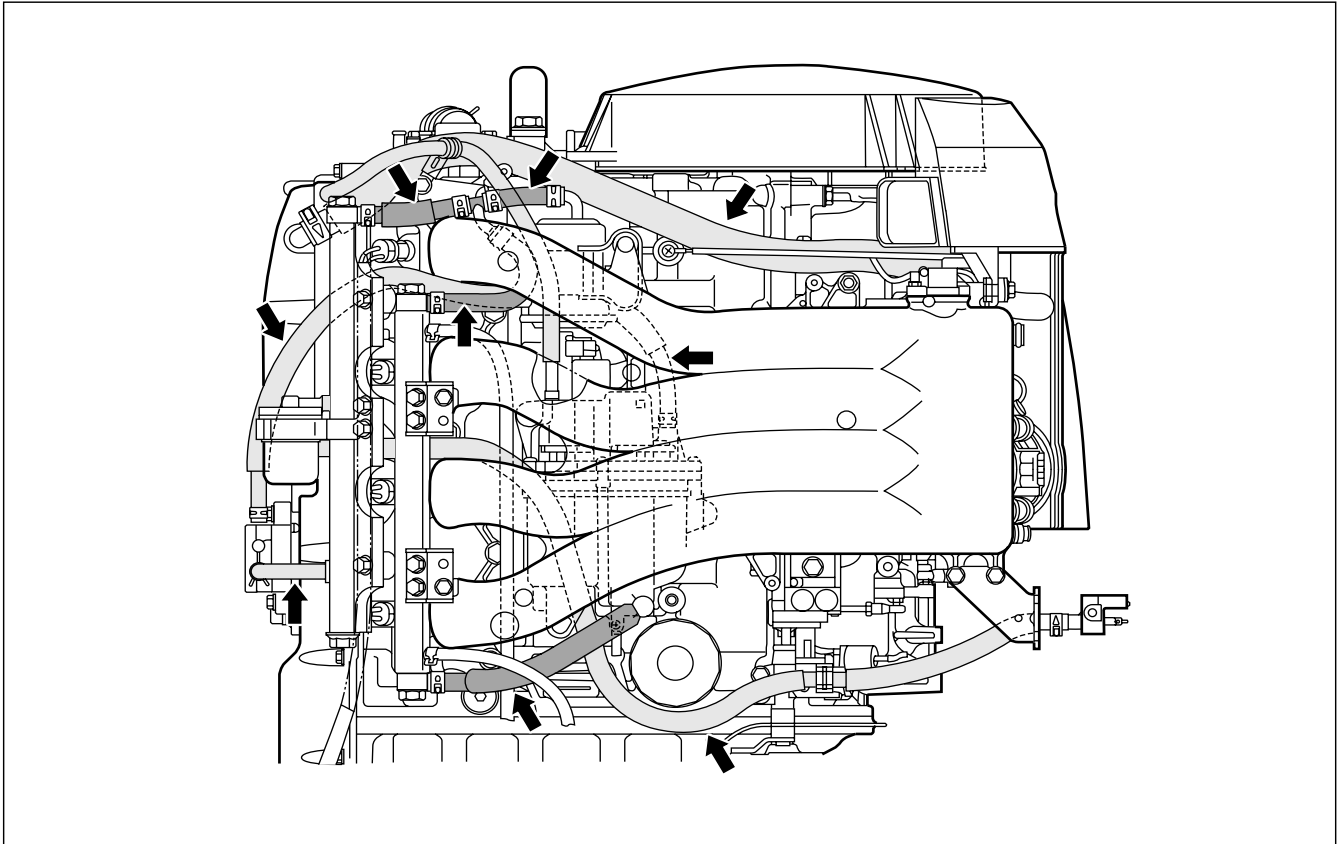

LOW PRESSURE FUEL FILTER

- Inspect every 50 hours (3 months).
- Replace every 400 hours or 2 years.

If water accumulation, sediment, leakage, cracks, or other damage is found, replace fuel filter.

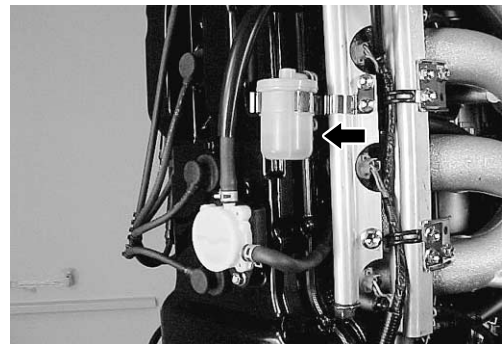

HIGH PRESSURE FUEL FILTER

Replace every 1000 hours.

SUZUKI recommends that high pressure fuel filter be replaced every 1000 operating hours.

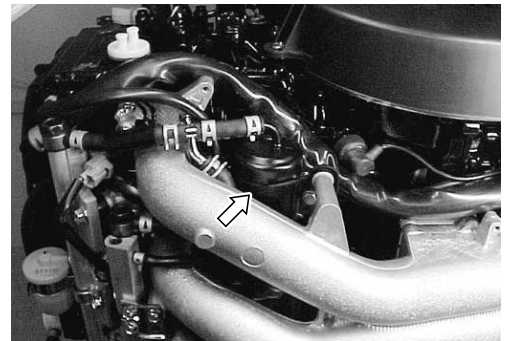

WATER PUMP / WATER PUMP IMPELLER

WATER PUMP
Inspect every 200 hours (12 months).

Inspect case and under panel.
Replace if wear, cracks, distortion or corrosion is found.

WATER PUMP IMPELLER
Replace every 200 hours (12 months).

Inspect water pump impeller.
Replace if vanes are cut, torn or worn.

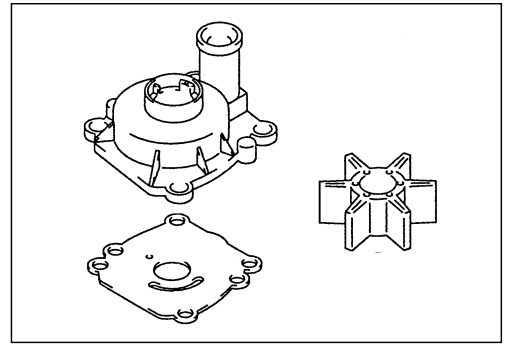

PROPELLER / NUT / COTTER PIN

Inspect initially after 20 hours (1 month) and every 100 hours (6 months).

- Inspect propeller for bent, chipped or broken blades.
Replace propeller if damage noticeably affects operation.
- Inspect propeller splines. Replace propeller if splines are worn, damaged or twisted.
- Inspect propeller bush for slippage.
Replace if necessary.
- Make sure that propeller nut is torqued to specification and cotter pin is installed securely.

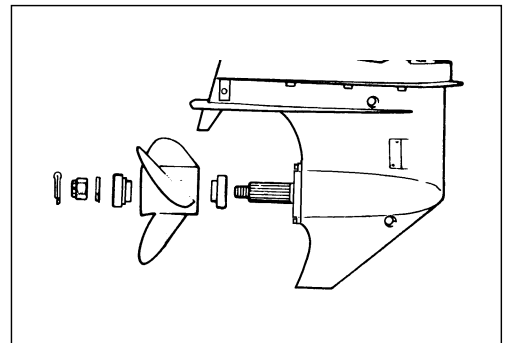

ANODES AND BONDING WIRES

Inspect every 50 hours (3 months).

ANODES

If 2/3 of zinc anode has corroded away, replace anode. The anode should be periodically cleaned with a wire brush to ensure maximum effectiveness.

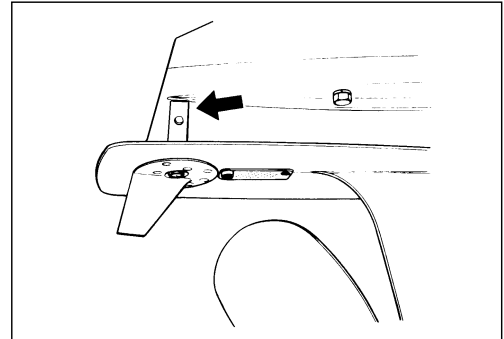
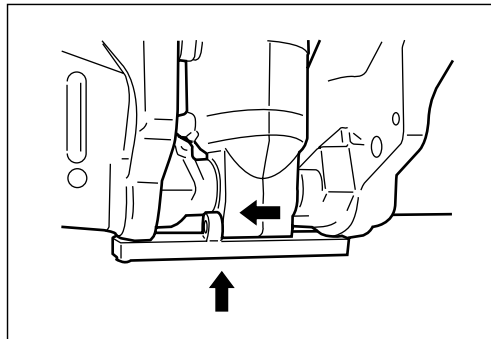
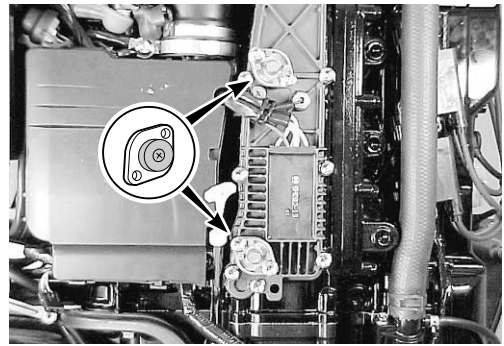

CAUTION

Never paint the anode.

NOTE:

The anode securing bolt should be covered with Suzuki Silicone Seal.

 99000-31120 : Suzuki Silicone Seal

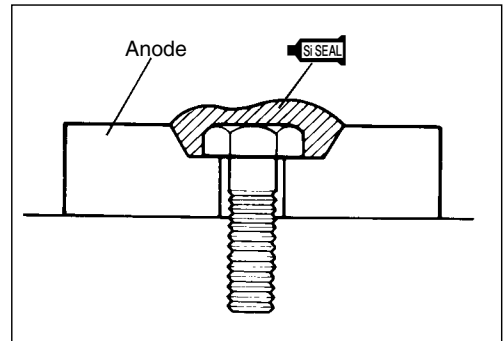

BONDING WIRES

- If breakage or other damage is found on bonding wire, replace wire.
- If rust, corrosion or other damage is found on terminal, clean with cleaning solvent or replace wire.

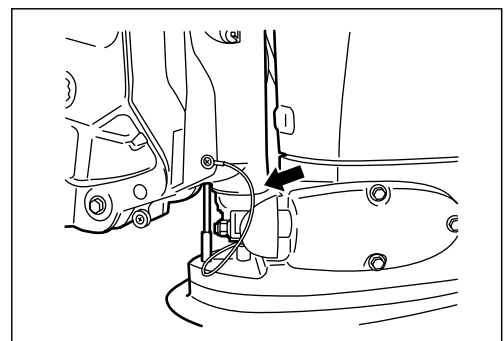
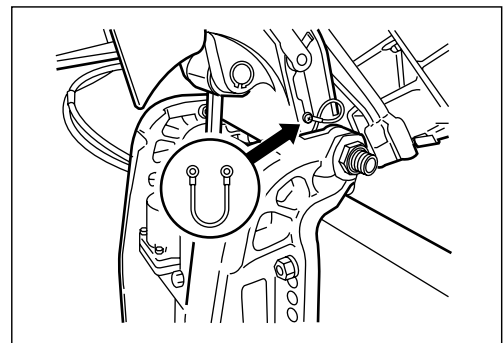

BATTERY

Inspect every 50 hours (3 months)

⚠ WARNING

- Never expose battery to open flame or electric spark as batteries generate gas, which is flammable and explosive.
- Battery acid is poisonous and corrosive. Avoid contact with eyes, skin, clothing, and painted surfaces. If battery acid comes in contact with any of these, flush immediately with large amounts of water. If acid contacts the eyes or skin, get immediate medical attention.
- Batteries should always be kept out of reach of children.
- When checking or servicing the battery, disconnect the negative (black) cable. Be careful not to cause a short circuit by allowing metal objects to contact the battery posts and the motor at the same time.
- Wear approved eye protection.

Recommended battery :

12 V 100 Ah (360 kC) or larger

CONNECTING BATTERY

Upon completion of connection, lightly apply grease to battery terminals.

How to connect :

1. Connect positive (+) terminal first.
2. Connect negative (-) terminal second.

How to disconnect :

1. Disconnect negative (-) terminal first.
2. Disconnect positive (+) terminal second.

CAUTION

If the battery leads are incorrectly connected, the electrical system could be damage.

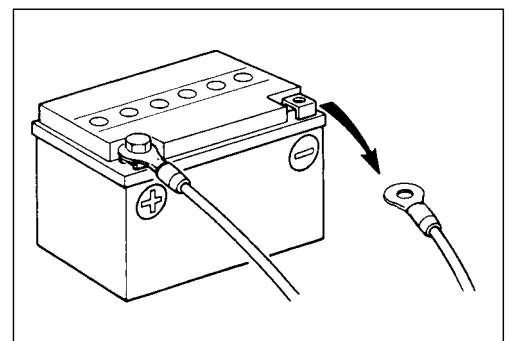
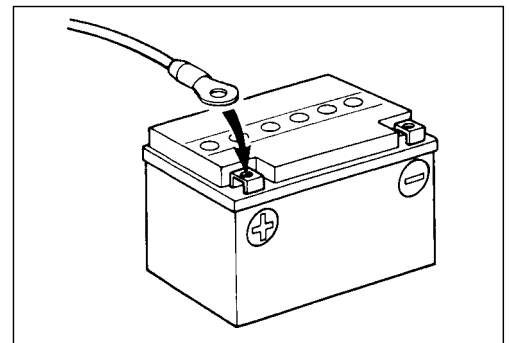

BATTERY SOLUTION LEVEL CHECK

Battery solution level should be between UPPER level and LOWER level.

If level is low, add distilled water only.

CAUTION

Once the battery has been initially serviced, **NEVER** add diluted sulfuric acid, or you will damage the battery. Follow the battery manufacture’s instructions for specific maintenance procedures.

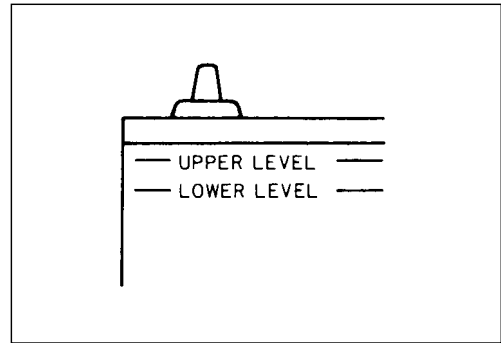

BATTERY SOLUTION GRAVITY CHECK

Measure gravity of battery solution using hydrometer.

Battery solution gravity : 1.28 at 20°C

 09900-28403 : Hydrometer

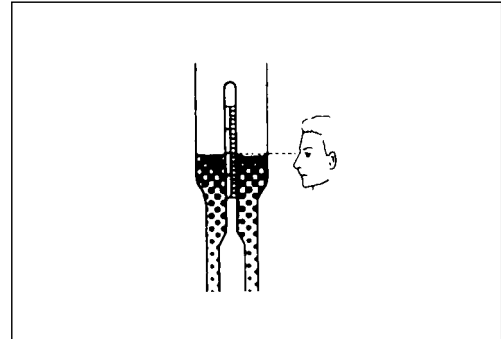

BOLT AND NUTS

Inspect initially after 20 hours (1 month) and every 100 hours (6 months).

Check that all bolts and nuts listed below are tightened to their specified torque.

ITEM	THREAD DIAMETER	TIGHTENING TORQUE		
		N·m	kg·m	lb.-ft.
Cylinder head cover bolt	6 mm	11	1.1	8.0
Flywheel bolt	16 mm	245	24.5	177.0
Power unit mounting bolt	8 mm	23	2.3	16.5
	10 mm	50	5.0	36.0
Clamp bracket shaft nut	22 mm	43	4.3	31.0
Lower mount bolt / nut	12 mm	60	6.0	43.0
Gearcase bolt	10 mm	55	5.5	40.0
Propeller nut	18 mm	55	5.5	40.0

FUEL MIXTURE CHECK (O₂ FEEDBACK)

Perform every 2 years.

To perform fuel mixture check (O₂ feedback) operation, use personal computer and Suzuki Diagnostic System software. For fuel mixture check (O₂ feedback) operation, refer to “Suzuki Diagnostic System Operation Manual”.

NOTE:

See “O₂ FEEDBACK SYSTEM” section on page 3-34 before starting O₂ feedback operation.

OIL PRESSURE

Oil pressure (at normal operating temp.) :
 550 – 600 kPa (5.5 – 6.0 kg/cm², 78 – 85 psi.)
 at 3000 r/min.

NOTE:

The figure shown above is a guideline only, not an absolute service limit.

If oil pressure is lower or higher than specification, following causes may be considered.

(See page 6-65 for oil passage locations)

Low oil pressure

- Clogged oil filter
- Leakage from oil passages
- Defective oil pump
- Defective oil pressure regulator
- Damage O-ring
- Combination of above items

High oil pressure

- Using an engine oil of too high viscosity
- Clogged oil passage
- Clogged oil pressure regulator
- Combination of above items

TEST PROCEDURE

1. Check engine oil level.
2. Remove bolts and air duct ① .

3. Loosen screw and disconnect blue lead wire from oil pressure switch ② .
 Remove oil pressure switch.

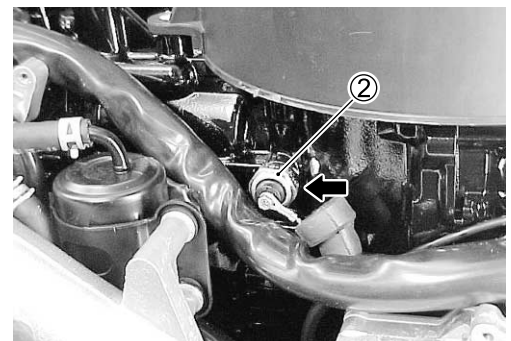
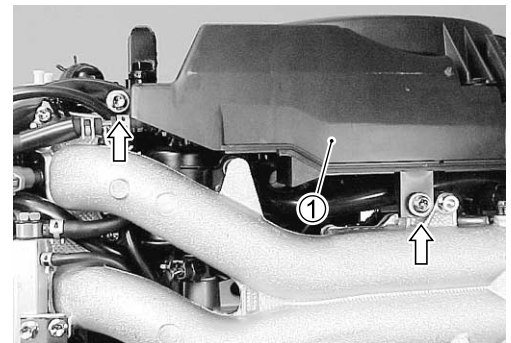

4. Install oil pressure gauge in place of pressure switch hole.



09915-77311 : Oil pressure gauge
09915-78211 : Oil pressure gauge adapter

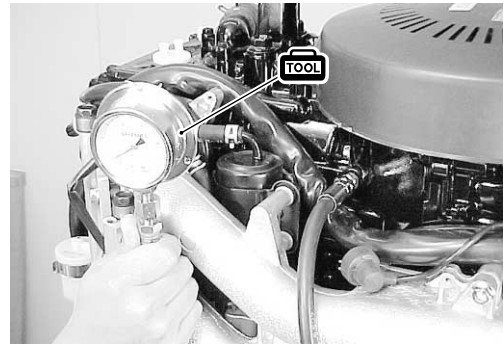

5. Attach engine tachometer to ignition coil high tension cord.



09900-26006 : Engine tachometer

6. Start engine and allow to warm up as follows :

Summer : 5 min. at 2000 r/min.

Winter : 10 min. at 2000 r/min.

7. After warming up, shift into forward gear and increase engine speed to 3000 r/min. then compare pressure indicated on gauge to specifications.
8. After testing, reinstall oil pressure switch. (See page 3-54)
9. Reinstall air duct.

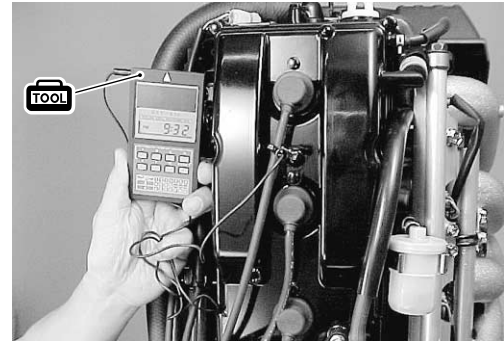

CYLINDER COMPRESSION

Cylinder compression :

Standard : 1300 – 1700 kPa

(13 – 17 kg/cm², 185 – 242 psi.)

Max. difference between any other cylinders :

100kPa (1.0 kg/cm², 14 psi.)

NOTE:

Figures shown are guidelines only, not absolute service limits.

Low compression pressure can indicate one or more of following :

- Excessively worn cylinder wall
- Worn piston or piston rings
- Stuck piston rings
- Poor seating of valves
- Ruptured or otherwise damaged cylinder head gasket

TEST PROCEDURE

1. Start engine and allow to warm up, then shut engine off.
2. Remove STBD / PORT side covers.(See page 7-2)
3. Remove all spark plugs.
4. Install compression gauge hose attachment into plug hole, then connect compression gauge hose to gauge hose attachment and compression gauge.

-  **09915-64512 : Compression gauge**
09915-64530 : Compression gauge hose
09915-67010 : Compression gauge hose attachment

5. Disconnect safety lanyard (switch plate) from emergency stop switch.

WARNING

Disconnect the safety lanyard from the emergency stop switch prior to cranking the engine. This will prevent any residual fuel discharged from the cylinders being ignited by a spark discharge from the spark plug caps.

6. Disconnect remote control throttle cable from throttle lever.
7. Move and hold throttle lever in full-open position.
8. While cranking engine with starter motor, note maximum compression pressure reading on gauge for each cylinder.
9. Reinstall parts removed earlier. (spark plugs, side covers, etc.)

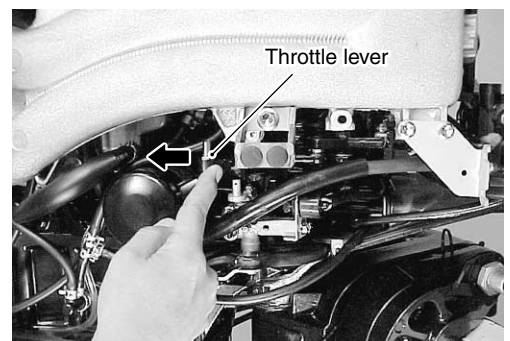
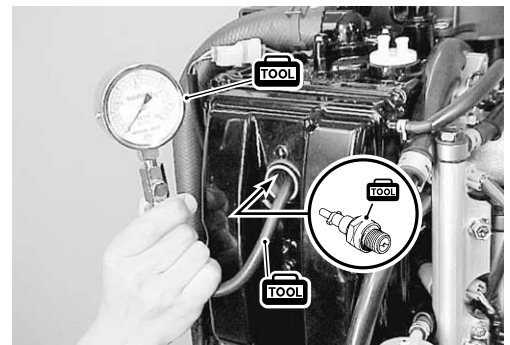

ENGINE CONTROL SYSTEM

CONTENTS

ENGINE CONTROL SYSTEM STRUCTURE	3-2
SYSTEM STRUCTURE 1	3-2
SYSTEM STRUCTURE 2	3-3
WIRING DIAGRAM FOR ENGINE CONTROL	3-4
COMPONENTS FOR SYSTEM CONTROL	3-5
ENGINE CONTROL MODULE (ECM)	3-5
ECM CONNECTOR / TERMINALS LAYOUT	3-6
ECM INTERNAL STRUCTURE	3-7
SENSOR AND SWITCH	3-8
IGNITION SYSTEM	3-12
IGNITION CONTROL SYSTEM	3-12
ELECTRONIC FUEL INJECTION SYSTEM	3-14
FUEL INJECTION CONTROL SYSTEM	3-14
FUEL DELIVERY SYSTEM COMPONENTS	3-16
FUEL PUMP CONTROL SYSTEM	3-19
AIR INTAKE COMPONENTS	3-20
IDLE AIR CONTROL SYSTEM	3-21
CAUTION SYSTEM	3-23
OVER-REVOLUTION CAUTION SYSTEM	3-23
LOW OIL PRESSURE CAUTION SYSTEM	3-24
OVERHEAT CAUTION	3-25
LOW BATTERY VOLTAGE CAUTION SYSTEM	3-26
SELF-DIAGNOSTIC SYSTEM	3-27
PRIORITY / CODE / PATTERN FOR SELF-DIAGNOSTIC SYSTEM OPERATION	3-27
CONDITION FOR SELF-DIAGNOSTIC SYSTEM OPERATION	3-29
FAIL-SAFE SYSTEM	3-30
PRE-PROGRAMMED VALUE FOR FAIL-SAFE SYSTEM	3-30
OPERATING HOUR INDICATION SYSTEM	3-31
OIL CHANGE REMINDER SYSTEM	3-32
START-IN-GEAR PROTECTION SYSTEM	3-33
O₂ FEEDBACK SYSTEM	3-34
INSPECTION	3-35
PRECAUTION ON SYSTEM INSPECTION	3-35
44-PIN TEST CORD	3-35
INSPECTION FOR ECM CIRCUIT VOLTAGE	3-36
INSPECTION FOR RESISTANCE	3-38
COMPONENT INSPECTIONS	3-39
TROUBLESHOOTING	3-45
REMOVAL / INSTALLATION	3-51
FLYWHEEL	3-51
CKP SENSOR / CMP SENSOR	3-53
OIL PRESSURE SWITCH	3-54

ENGINE CONTROL SYSTEM STRUCTURE

The DF90/DF115 models employ an integrated control system which performs the control functions for fuel injection, ignition, idle / trolling speed (idle air), etc. through the ECM (Engine Control Module).

SYSTEM STRUCTURE 1

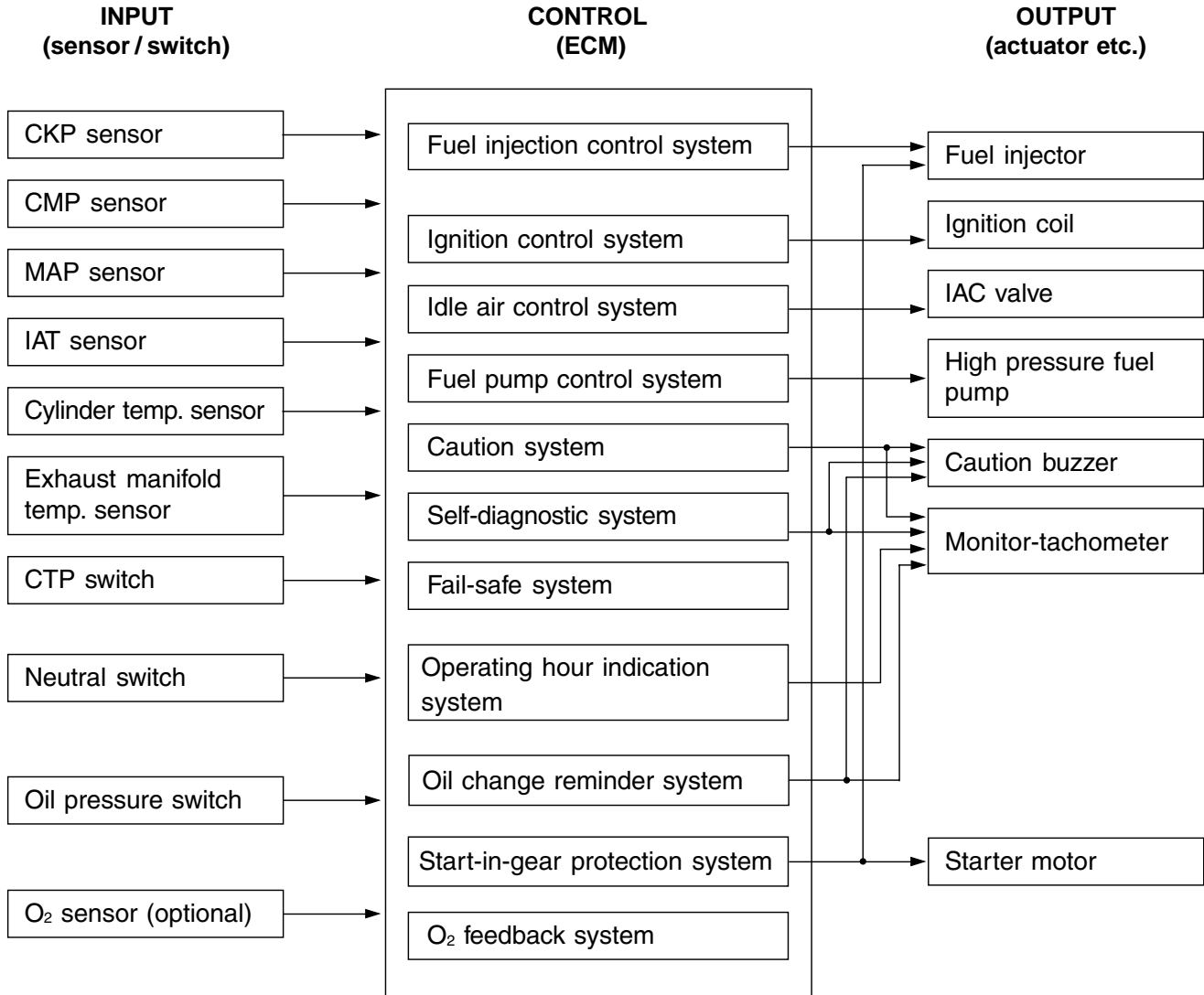

[Abbreviations used in this section]

- ECM (Engine control module)
- CKP (Crankshaft position)
- CMP (Camshaft position)
- MAP (Manifold absolute pressure)
- IAT (Intake air temperature)
- CTP (Closed throttle position)
- IAC (Idle air control)

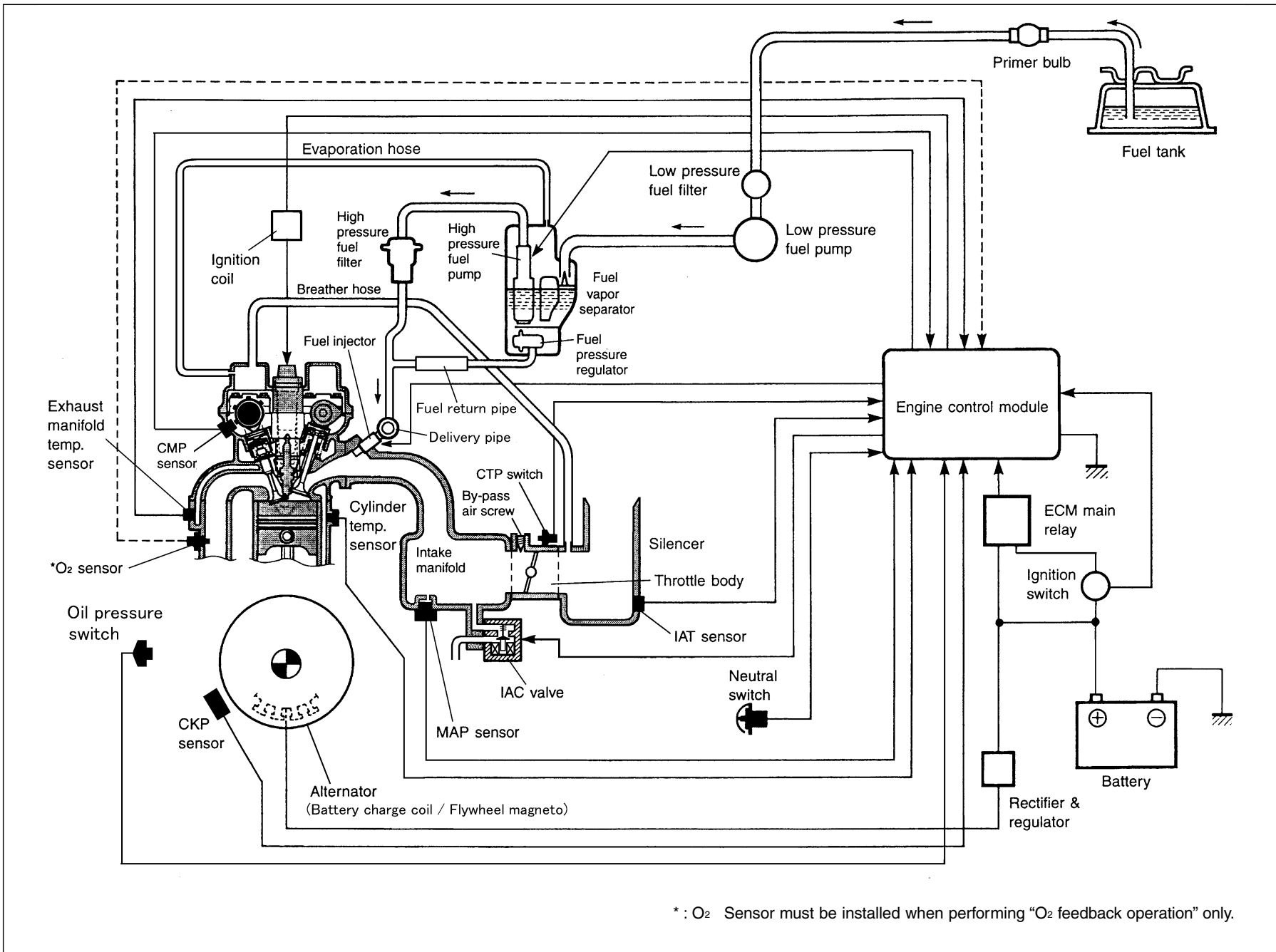

* : O₂ Sensor must be installed when performing "O₂ feedback operation" only.

WIRING DIAGRAM FOR ENGINE CONTROL

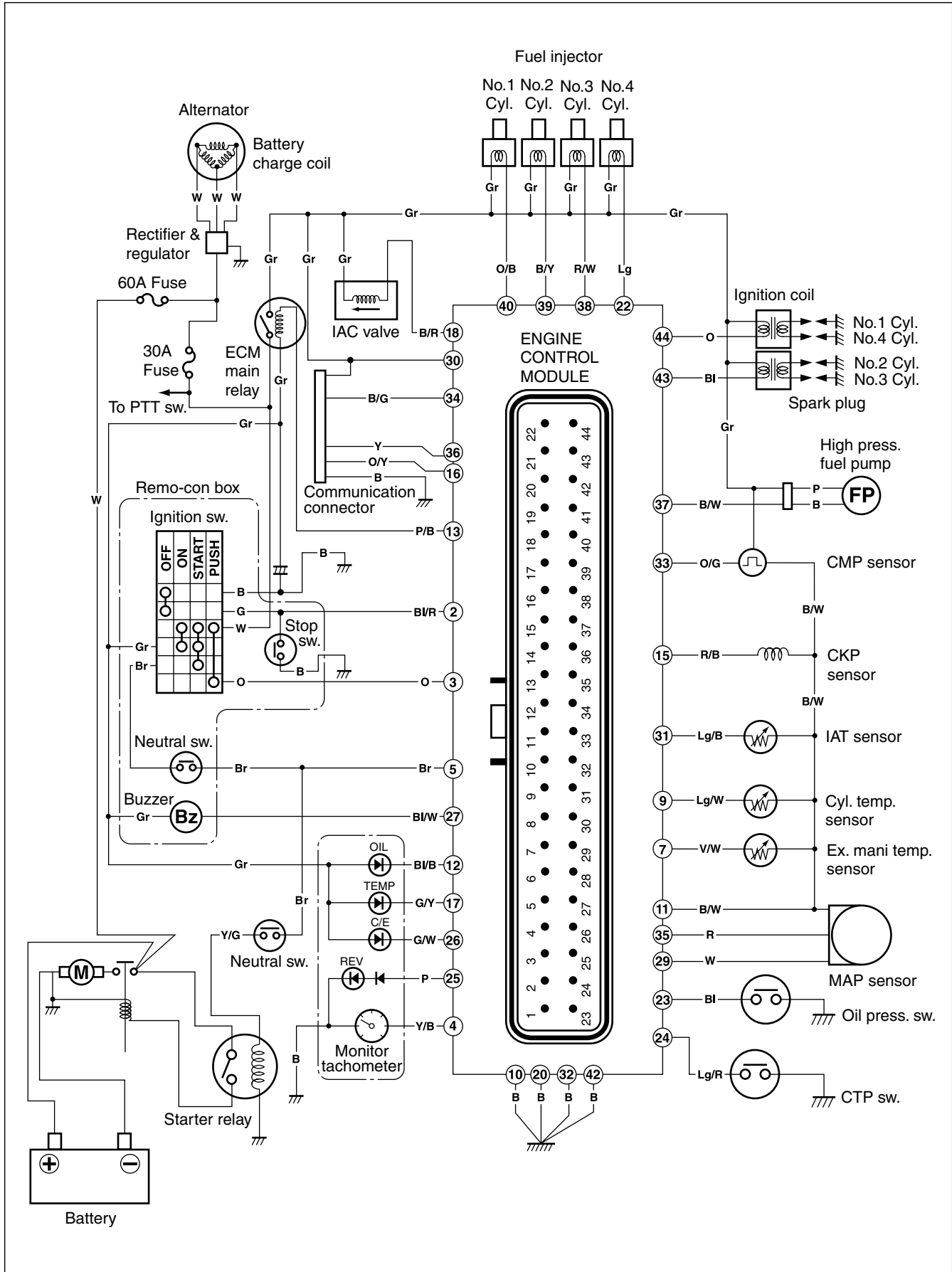

COMPONENTS FOR SYSTEM CONTROL

ENGINE CONTROL MODULE (ECM)

The ECM sends signals to control the actuators based on the information inputs from each sensor / switch. Major controls are as follows :

NAME OF CONTROL	DESCRIPTION
Fuel injection control	<ul style="list-style-type: none"> Controls fuel injection amount and timing.
Ignition control	<ul style="list-style-type: none"> Controls ignition timing.
Idle air control	<ul style="list-style-type: none"> Controls idling / trolling speed by adjusting intake air amount through IAC valve.
Fuel pump control	<ul style="list-style-type: none"> Controls high pressure fuel pump drive.
Caution system control	<ul style="list-style-type: none"> Informs operator of abnormal engine condition. Controls engine speed.
Self-diagnostic system control	<ul style="list-style-type: none"> Informs operator of sensor / switch malfunction.
Fail-safe system control	<ul style="list-style-type: none"> Allows operation during sensor / switch malfunction.
Operating hour indication system control	<ul style="list-style-type: none"> Informs operator of total operating time.
Oil change reminder system control	<ul style="list-style-type: none"> Informs operator of the required engine oil replacement intervals based on the maintenance schedule.
Start-in-gear protection system control	<ul style="list-style-type: none"> Prevents engine start when shift is positioned in forward or reverse.
O ₂ feedback system control	<ul style="list-style-type: none"> Controls and performs O₂ feedback operation using optional O₂ sensor.

NOTE:

Information related to the Caution system, Self-diagnostic system, Total operating hour indication system, Oil change reminder system and O₂ feedback system are retained in ECM memory.

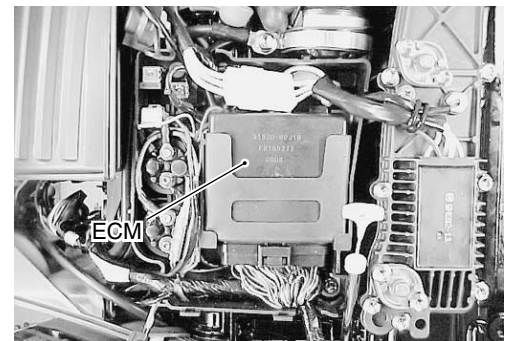

ECM CONNECTOR / TERMINALS LAYOUT

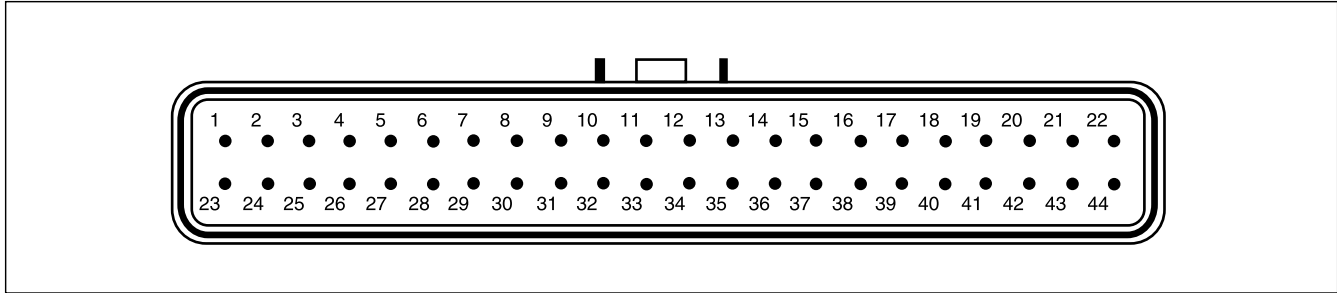

ECM CIRCUITS

TERMI-NAL	WIRE COLOR	CIRCUIT
1	—	—
2	Bl/R	Emergency stop switch
3	O	Buzzer cancel
4	Y/B	Tachometer
5	Br	Neutral switch
6	—	—
7	V/W	Ex-manifold temp. sensor
8	—	—
9	Lg/W	Cylinder temp. sensor
10	B	Ground for ECM
11	B/W	Ground for sensors
12	Bl/B	Oil lamp
13	P/B	Ground for ECM main relay
14	—	—
15	R/B	CKP sensor
16	O/Y	PC communication
17	G/Y	TEMP lamp
18	B/R	IAC valve solenoid (-)
19	—	—
20	B	Ground for ignition coil
21	—	—
22	Lg	No.4 Fuel injector (-)

TERMI-NAL	WIRE COLOR	CIRCUIT
23	Bl	Oil pressure switch
24	Lg/R	CTP switch
25	P	REV-LIMIT lamp
26	G/W	CHECK ENGINE lamp
27	Bl/W	Buzzer
28	—	—
29	W	MAP sensor
30	Gr	ECM power source
31	Lg/B	IAT sensor
32	B	Ground for ECM
33	O/G	CMP sensor
34	B/G	O ₂ feedback / PC communication
35	R	Power source for MAP sensor
36	Y	PC communication
37	B/W	Fuel pump (-)
38	R/W	No.3 Fuel injector (-)
39	B/Y	No.2 Fuel injector (-)
40	O/B	No.1 Fuel injector (-)
41	—	—
42	B	Ground for ignition coil
43	Bl	No.2 Ignition coil (-)
44	O	No.1 Ignition coil (-)

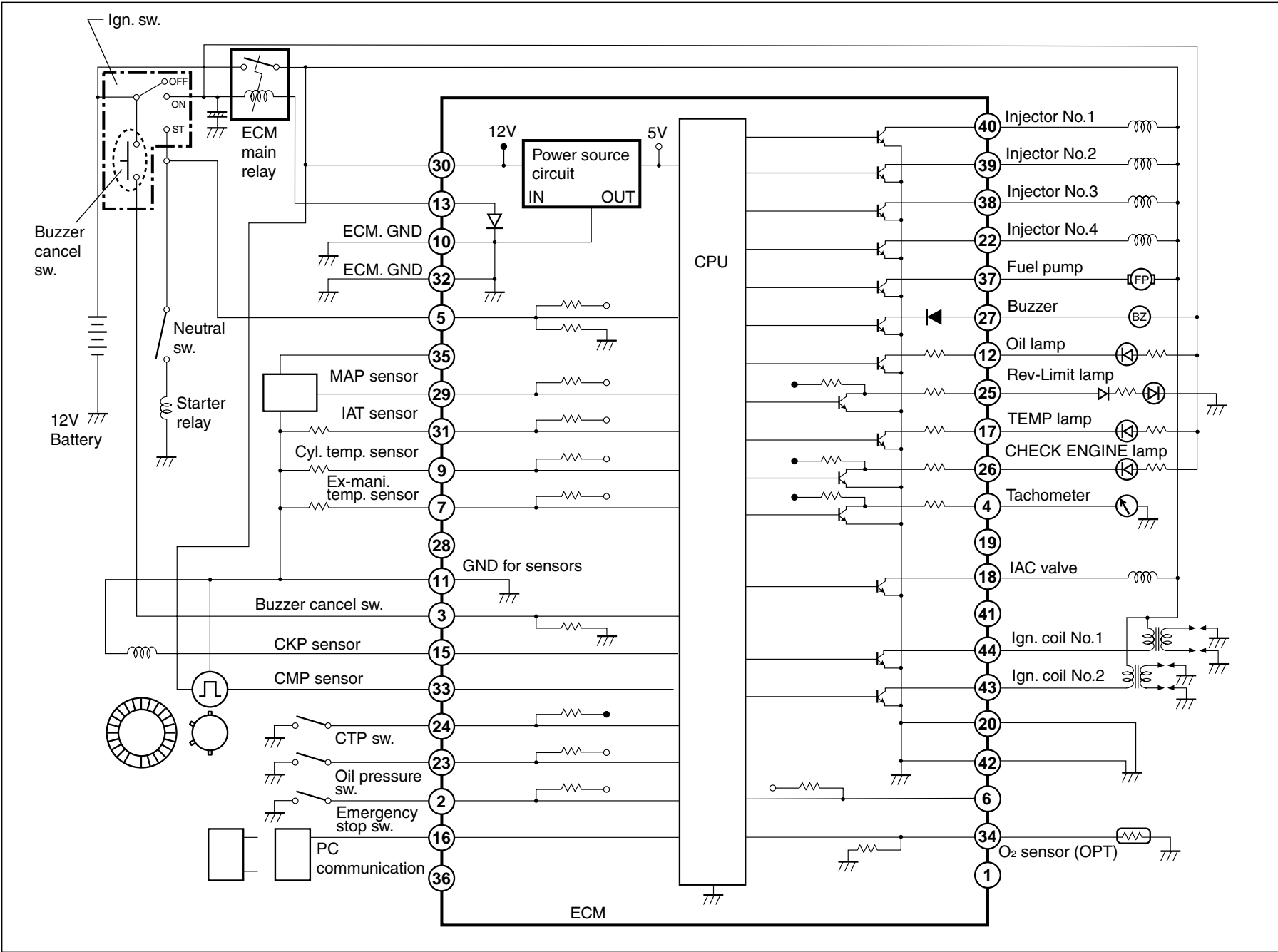

ECM INTERNAL STRUCTURE

SENSOR AND SWITCH

CKP (Crankshaft Position) SENSOR

There is one (1) CKP sensor installed below the flywheel rotor. When the reluctor bars on the flywheel pass the sensor, a signal (voltage pulse) is generated and sent to the ECM.

This is the fundamental signal used to judge the engine speed and crankshaft angle.

There are 34 reluctor bars, spaced 10 degrees apart, followed by a larger index space. During one crankshaft rotation, 34 signals are input to the ECM.

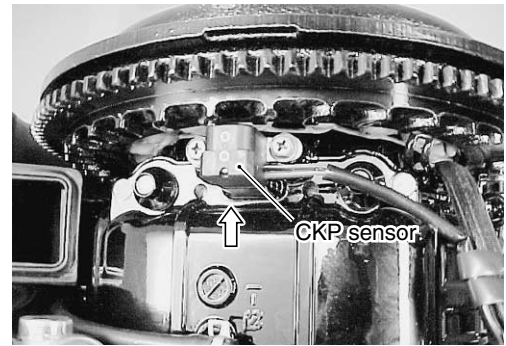

CMP (Camshaft Position) SENSOR

A CMP sensor mounted on the cylinder head cover and trigger vanes pressed onto the end of the exhaust camshaft are used to detect piston position. The signal from this sensor is received by the ECM which uses it to determine sequential fuel injection control.

The CMP sensor contains a "Hall Effect" semiconductor and a magnet. The semiconductor generates a voltage in proportion to the line of magnetic force passed through it. When a trigger vane on the camshaft reluctor aligns with the sensor's internal magnet, a large amount of magnetic force is generated allowing a high voltage to pass through the semiconductor. When the trigger vane moves away from the sensor, no magnetic force is generated and low voltage passes through the semiconductor.

These generated voltages are rectified to create "ON" (high voltage) & "OFF" (low voltage) signals to the ECM.

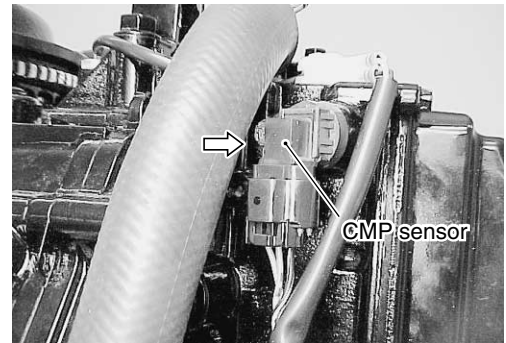

Four trigger vanes are provided on exhaust camshaft and during one rotation of camshaft (two rotations of crankshaft), four high voltage signals are supplied from CMP sensor to ECM.

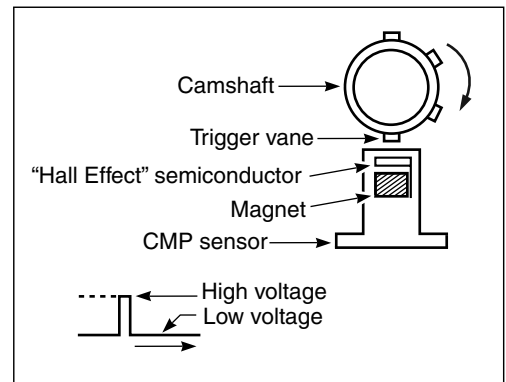

ECM cylinder identification :

The cylinder is identified by a calculation combined from two signals ; one from the CKP sensor and one from the CMP sensor.

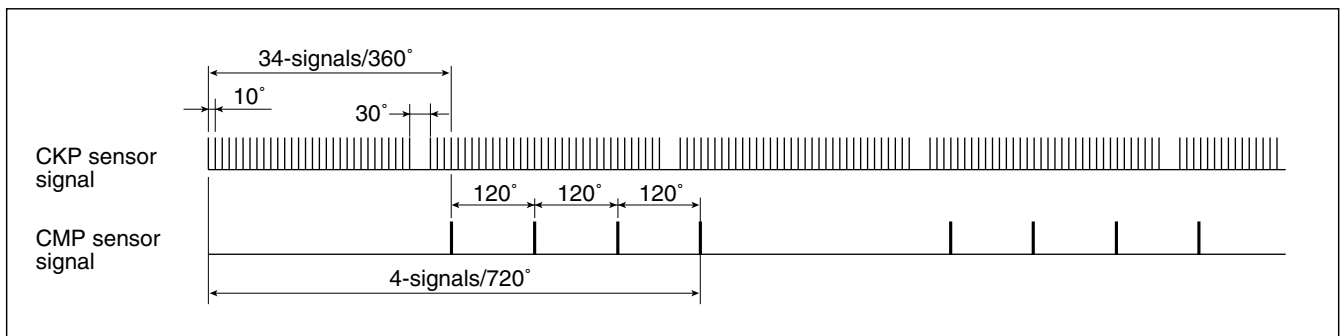

CYLINDER TEMPERATURE SENSOR

The cylinder temperature sensor is installed on the cylinder (top side) and used to detect the cylinder temperature.

This is a thermistor type sensor (resistance of which changes depending on the temperature) and inputs a signal to the ECM as a voltage value. This input signal is used to compensate the fuel injection time duration, ignition timing, etc.

This sensor is also used to detect engine over-heat as the ECM detects both the temperature and temperature change gradient (temperature rise vs time).

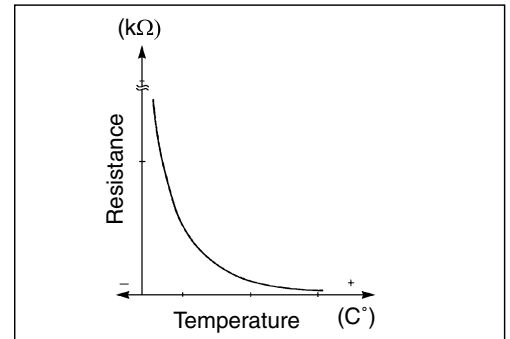
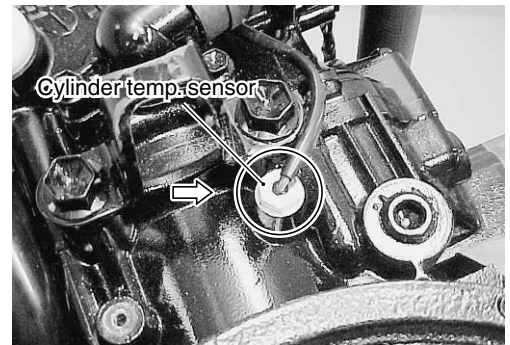

EXHAUST MANIFOLD TEMPERATURE SENSOR

The exhaust manifold temperature sensor is installed on the exhaust manifold and used to detect the exhaust manifold temperature. This sensor is the same type as the cylinder temperature sensor, and inputs a signal to the ECM as a voltage value. This input signal is also used to detect engine over-heat.

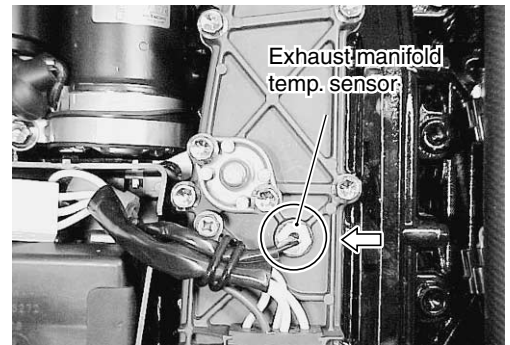

IAT (Intake Air Temperature) SENSOR

The IAT sensor is installed on the bottom of the air silencer and used to detect the intake air temperature.

This sensor is the same type as the cylinder temperature sensor, and inputs a signal to the ECM as a voltage value.

This input signal is used to compensate the fuel injection time duration.

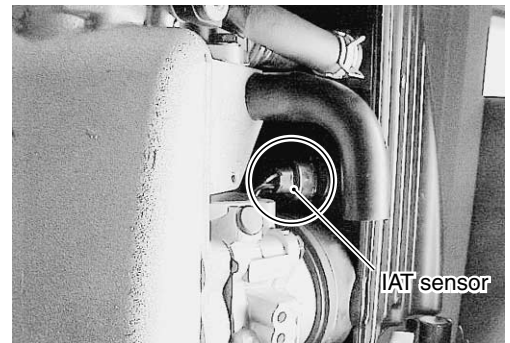

MAP (Manifold Absolute Pressure) SENSOR

The MAP sensor is installed on the intake manifold and used to detect the intake manifold pressure. It also detects the barometric pressure before starting the engine. This sensor inputs the intake manifold pressure to the ECM as a voltage value. This input signal is used as the fundamental signal to determine the fuel injection time duration, ignition timing, etc.

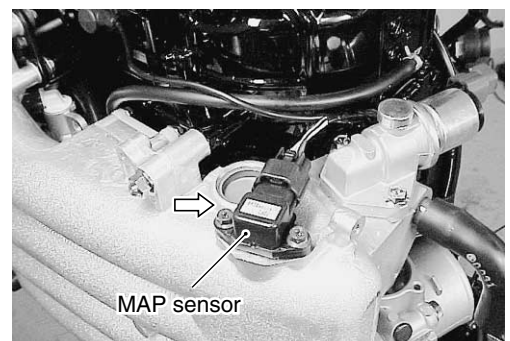

CTP (Closed Throttle Position) SWITCH

The CTP switch is installed on the bottom of throttle body and used to detect whether the throttle is fully closed or not.

This switch is “ON” at closed throttle and “OFF” at any open throttle position. Based on the switch’ throttle position signal input, the ECM determines the control modes for various control system (idle air control, ignition timing control, etc.).

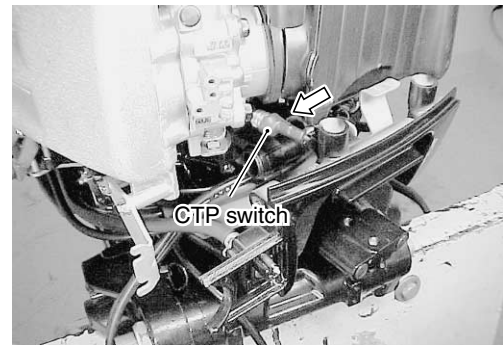

NEUTRAL SWITCH

The neutral switch is installed on the cylinder block (STBD side) and used to detect the shift position.

This switch is “ON” in neutral and “OFF” in forward or reverse. Based on the switch’ shift position signal input, the ECM performs the following controls :

- When the shift is in forward or reverse at the time of engine start, the fuel injection function is cancelled. (Start-in-gear protection. See page 3-33.)
- When the shift is in neutral, fuel injection is controlled so that the engine speed does not exceed 3000 r/min.
- When the shift is in neutral, if the engine speed exceeds 900 r/min., ignition timing is fixed at BTDC 8°.
- After shifting into forward or reverse from neutral, the IAC valve is controlled to increase intake air for two seconds to prevent unstable engine idle or stalling.

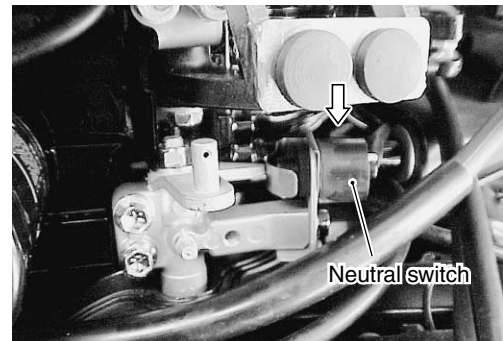

ECM MAIN RELAY

The ECM main relay is installed in the electric parts holder. When energized by the turning ignition switch ON, it forms the circuit which supplies battery voltage to the ECM, injector, ignition coil, IAC valve, CMP sensor and high pressure fuel pump.

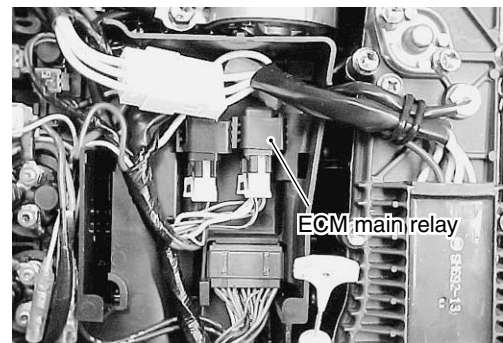

O₂ SENSOR (Optional item)

The O₂ sensor is installed in the exhaust manifold only when the O₂ feedback operation is performed.

This sensor is a zirconia element (platinum plated) which changes output voltage depending on the oxygen concentration difference between its internal and external surfaces. The voltage change reflects the concentration of the oxygen in the exhaust gas and is used to perform the O₂ feedback operation.

The terminal voltage change (0 – 1 V) is dependent on the concentration of oxygen in the exhaust gas.

This detected voltage value therefore represents the oxygen concentration. The terminal voltage decreases when the oxygen concentration is high, and increases when it is low.

NOTE:

As the zirconia element is not conductive below 250°C, the O₂ sensor will not function properly until the engine is at normal operating temperature.

NOTE:**Zirconia element**

The zirconia element produces a potential difference (voltage) when there is a difference in the oxygen concentration of the gases which contact the two sides of the element.

Since the inner surface of the zirconia element (inside the sensor) is exposed to atmospheric air and the outer surface exposed to the exhaust gas, there is a difference in oxygen concentration on each side and thus a difference in the potential generated.

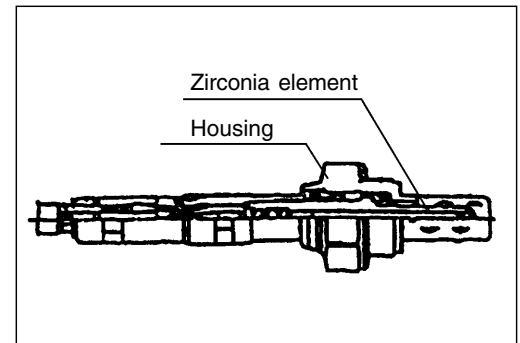

IGNITION SYSTEM

The ignition system used by the DF90/DF115 is a fully transistorized, electronic microcomputer timing advanced type.

This system is totally battery powered, with the ECM controlling all ignition timing functions.

The ignition system is composed of the ignition coil, spark plug and components for system control (ECM, sensor, switch, etc.).

When the ignition switch is "ON", battery voltage (12V) is applied to the circuit as shown in the illustration.

At the calculated time of ignition, the transistor in the ECM turns "OFF", breaking the ground circuit.

In this way, a mutual induction high voltage occurs in the ignition coil secondary side and spark is generated.

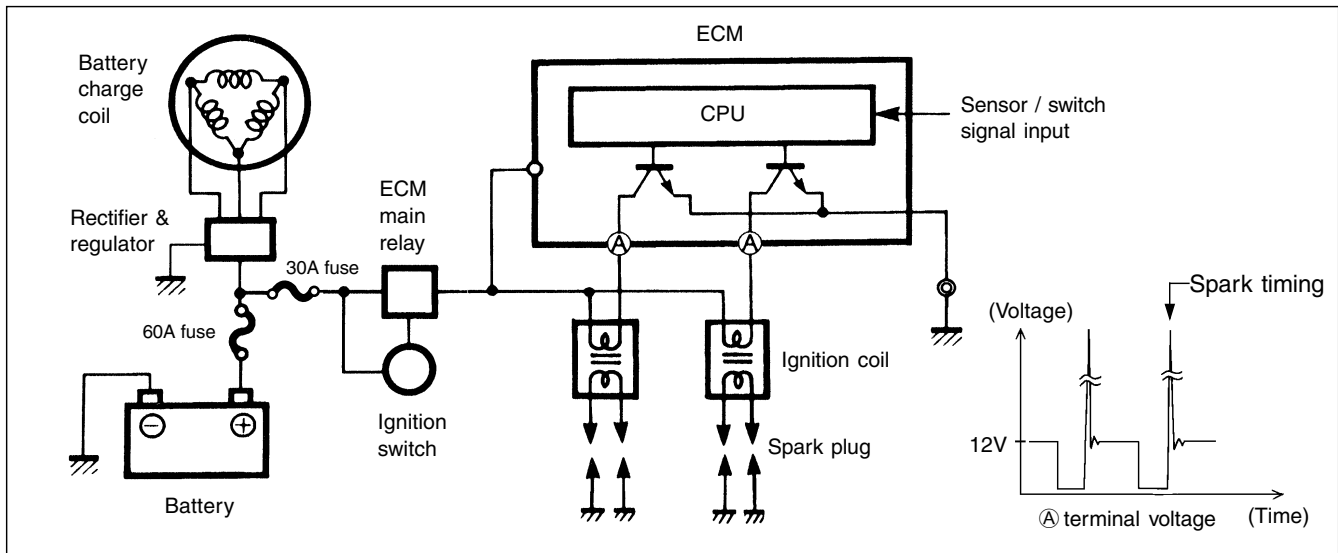

IGNITION CONTROL SYSTEM

OUTLINE

Sensors at specific points on the engine monitor current engine conditions and send signals to the ECM.

Based on these signals, the ECM determines the optimum ignition timing and releases voltage to the ignition coils.

Basic sensors

- MAP sensor :**
Informs ECM of intake manifold pressure.
- CKP sensor :**
Informs ECM of engine speed and crankshaft angle.

Compensating sensors

- Cylinder temperature sensor :**
Informs ECM of cylinder temperature.

Others

- CTP switch :**
Informs ECM of throttle position (open / closed).
- Ignition switch :**
Informs ECM of "START" signal.

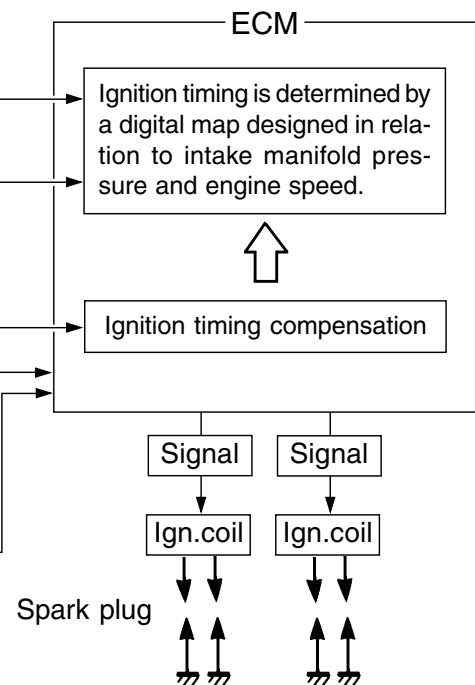

IGNITION TIMING CHART

The following chart is an example for ignition at BTDC 30°.

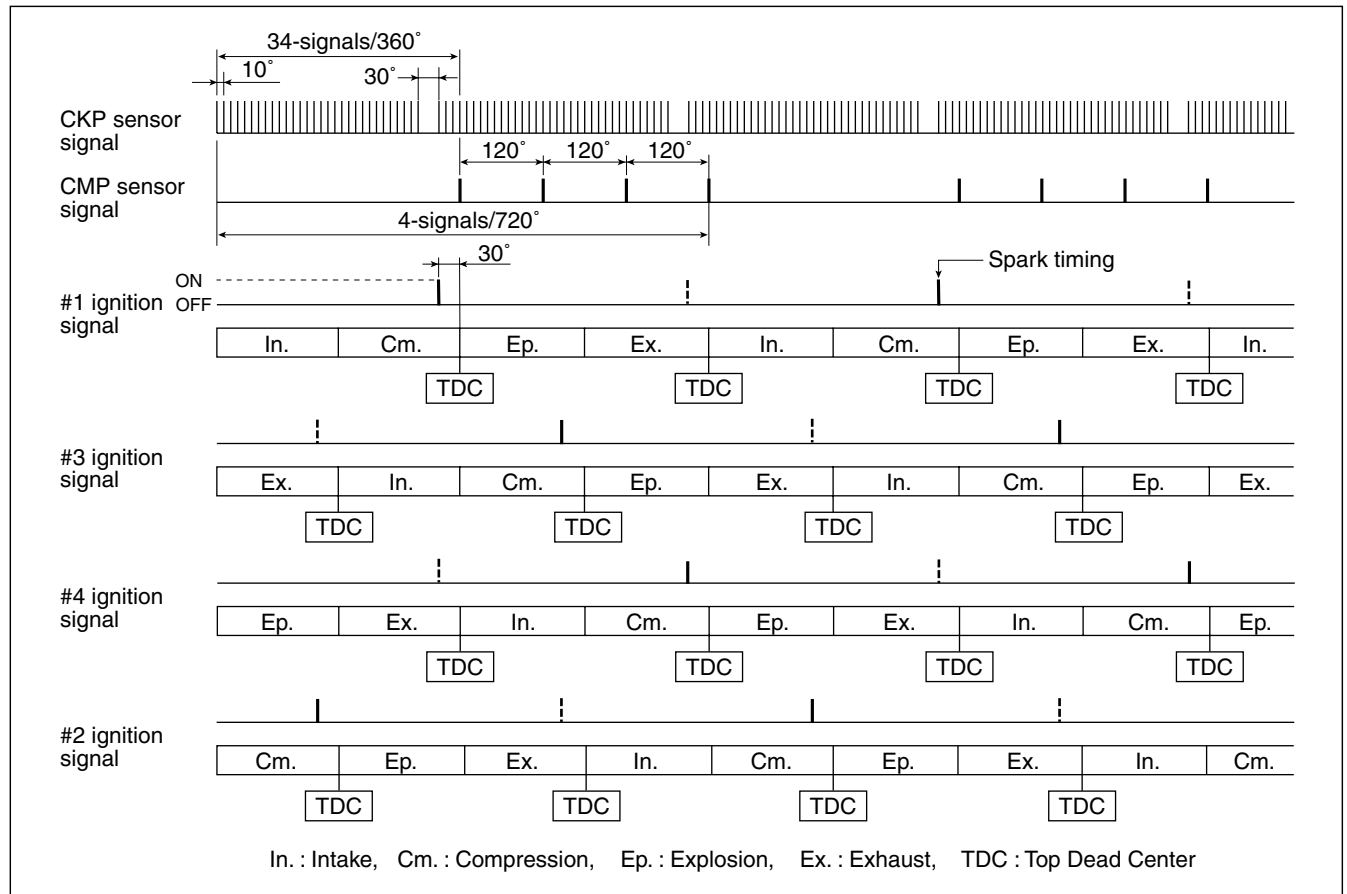

CONTROL MODE

WHEN CRANKING :

The ignition timing is fixed at BTDC 5° until the engine starts.

WHEN IDLING / TROLLING :

The ignition timing is controlled within the range of BTDC 3° to 13° to provide stable engine operation at the specified idling / trolling speed.

When the shift lever is in neutral, if engine speed exceeds 900 r/min., ignition timing remains fixed at BTDC 8°.

WHEN RUNNING (NORMAL OPERATION) :

The ignition timing ranges between BTDC 1° – 44° (DF90) or BTDC 3° – 44° (DF115), depending on current engine operating conditions.

WHEN DECELERATING :

When the throttle valve is closed suddenly, turning the CTP switch “ON”, the return of ignition timing to the closed throttle specification (idle speed) is delayed for a programmed duration to prevent engine stalling or unstable running.

SPECIFICATION

Ignition system	Full-transistorized ignition
Advance	Electronic microcomputer control
Ignition timing	DF 90 : BTDC 1° – 44°, DF 115 : BTDC 3° – 44°
Firing order	1 – 3 – 4 – 2

ELECTRONIC FUEL INJECTION SYSTEM

The fuel injection system used by the DF90/DF115 is a speed-density, multi-point, sequential, electronic fuel injection type.

The fuel injection system is composed of the fuel line components, air intake components, and components for system control (ECM, sensors, switches, etc.).

FUEL INJECTION CONTROL SYSTEM

OUTLINE

Sensors are mounted at precise locations on the motor to monitor the current conditions of engine operation and send signals to the ECM. Based on these signals, the ECM determines the optimum fuel injection time duration (fuel amount), fuel injection timing (multi-point sequential timing) and controls the injector operating signals accordingly.

Fuel injection start timing is set at BTDC445° on exhaust stroke constant.

Basic sensors

- MAP sensor :**
Informs ECM of intake manifold pressure.
- CKP sensor :**
Informs ECM of engine speed and crankshaft angle.

Compensating sensors

- Cylinder temperature sensor :**
Informs ECM of cylinder temperature.
- IAT sensor :**
Informs ECM of intake air temperature.
- MAP sensor :**
Informs ECM of barometric pressure at time of engine starting.
- Battery voltage :**
Constantly monitored by the ECM.

Others

- CMP sensor :**
Informs ECM of camshaft angle.
- CTP switch :**
Informs ECM of throttle position (open / closed).
- Neutral switch :**
Informs ECM of shift position (Neutral or in gear).

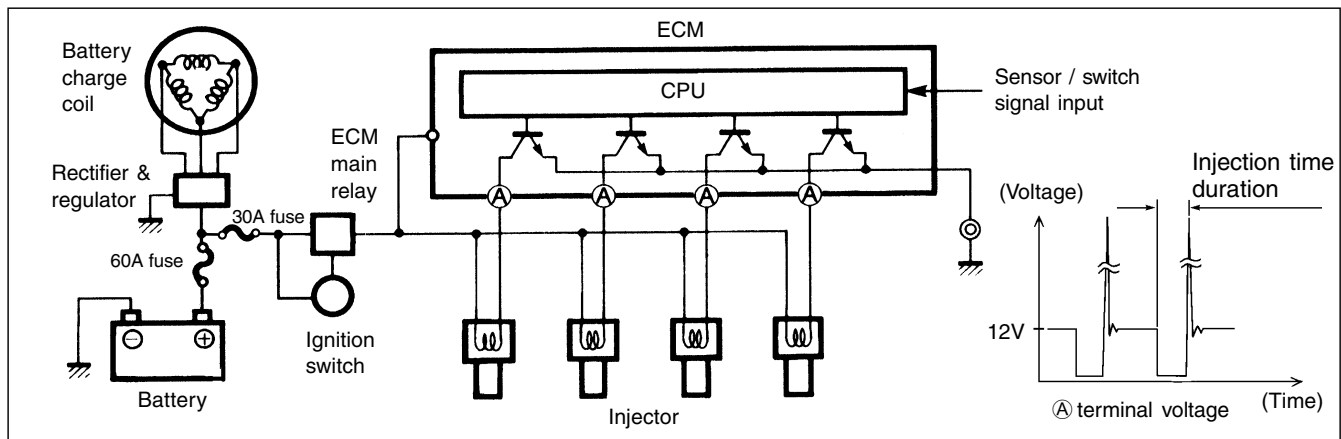
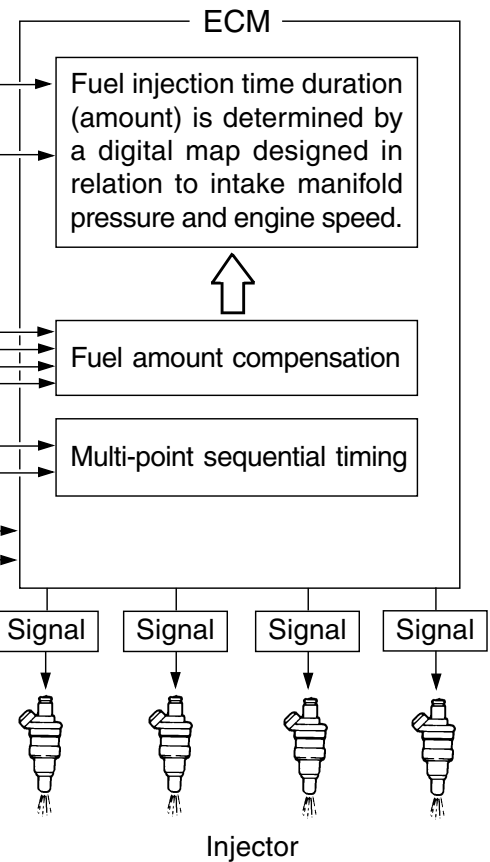

FUEL INJECTION TIMING CHART

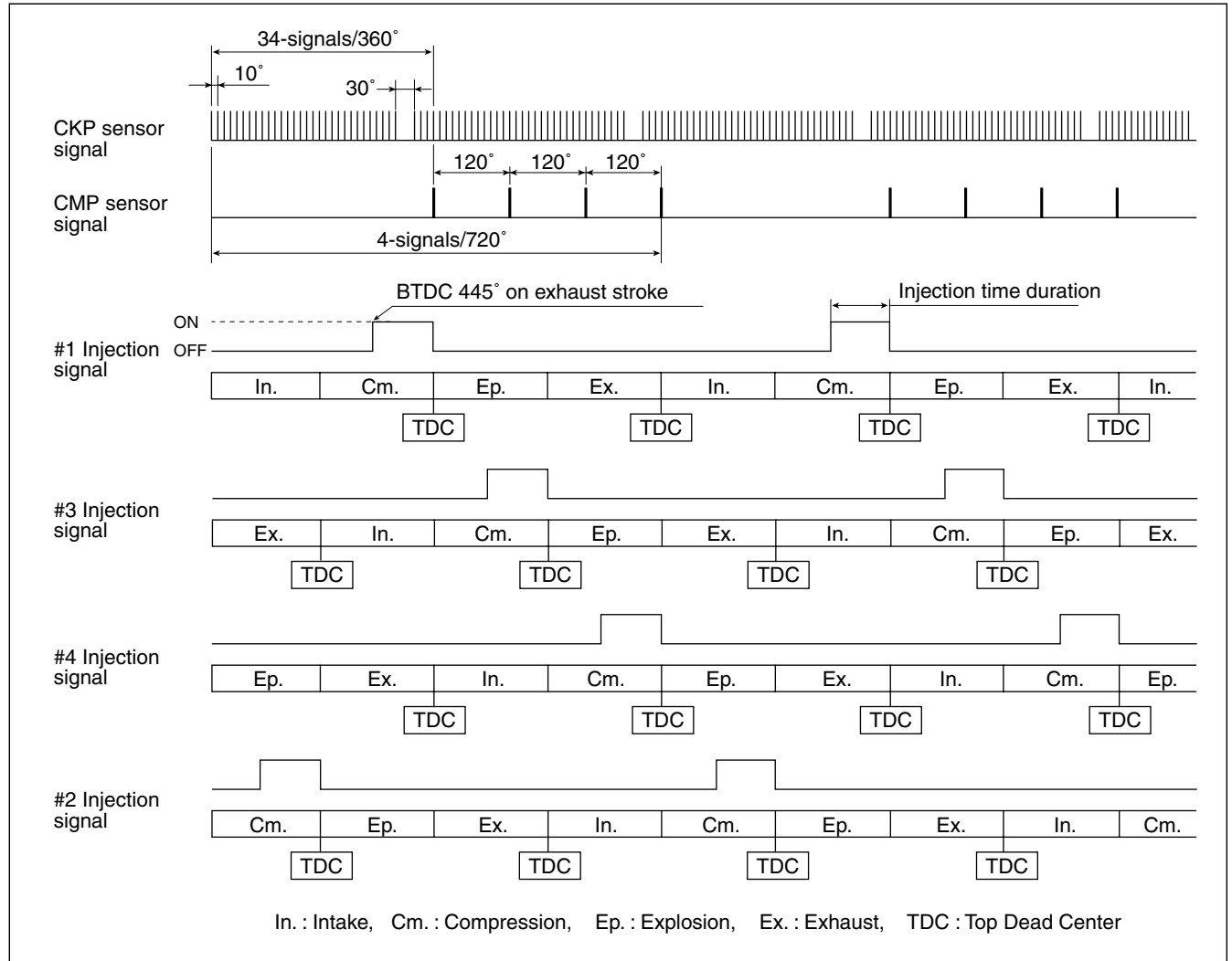

CONTROL MODE

BEFORE START :

When the ignition switch is turned “ON”, the ECM receives a MAP sensor signal, indicating the static barometric pressure of the intake manifold. This signal is used to compensate the fuel injection map for altitude.

WHEN CRANKING :

Fuel is simultaneously injected to all cylinders every time any piston is positioned at compression stroke.

AFTER START (FAST-IDLE FUNCTION):

The fuel injection amount is controlled to remain increased until the timer, set according to cylinder temperature at the time of engine start, expires.

WHEN IDLING / TROLLING :

The fuel injection amount is controlled to maintain a stable engine speed at the specified idle / trolling rpm.

WHEN ACCELERATING :

The fuel injection amount is controlled to increase.

WHEN DECELERATING :

The fuel injection amount is controlled to decrease.

The fuel injection is also cut off on very rapid engine deceleration.

FUEL DELIVERY SYSTEM COMPONENTS

The fuel delivery system is composed of the low pressure line components (fuel tank, filter, pump, etc.), fuel vapor separator, high pressure fuel pump, high pressure fuel filter, fuel pressure regulator (located in the fuel vapor separator), delivery pipe, fuel injector and hoses.

Fuel is supplied through the primer bulb, low pressure fuel filter, and low pressure pump to the fuel vapor separator.

Fuel flow from the fuel vapor separator is pressurized by the high pressure fuel pump and supplied through the high pressure fuel filter and fuel delivery pipe to the fuel injectors.

The pressure regulator maintains fuel pressure in the feed line between the high pressure fuel pump and fuel injector.

This pressure, maintained at a constant level, is higher than the pressure in the vapor separator chamber.

When fuel feed line pressure exceeds vapor separator chamber pressure by more than approx. 255 kPa (2.55 kg/cm², 36.3 psi.), the valve in the fuel pressure regulator will open and return the excess fuel to the vapor separator chamber.

Pressurized fuel enters into the intake ports through the fuel injector based on the sequential signals supplied from the ECM.

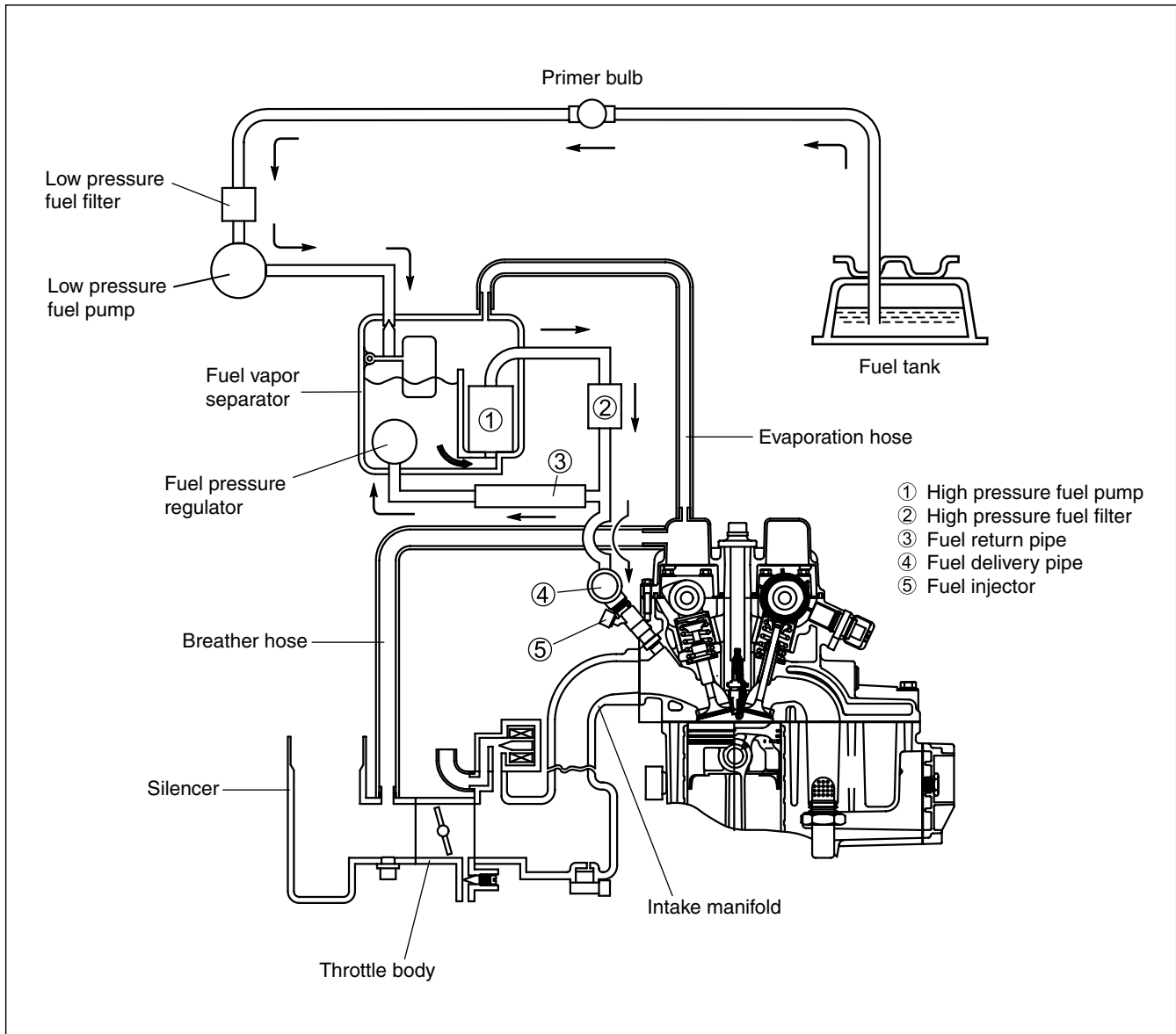

FUEL VAPOR SEPARATOR

The fuel vapor separator incorporates a float system that maintains a constant fuel level inside the separator chamber.

As the fuel level decreases, fuel flows into the vapor separator from the low pressure fuel pump.

The function of this unit is to separate vapors from fuel delivered by the low pressure fuel pump or fuel returned from the fuel pressure regulator.

This vapor is routed through the evaporation hose connecting the vapor separator cover to the cylinder head cover.

HIGH PRESSURE FUEL PUMP

The high pressure fuel pump is an “integral” type in which the pump mechanism is located within the fuel vapor separator.

To supply the optimum fuel amount, the pump is driven by the duty cycle signal from ECM.

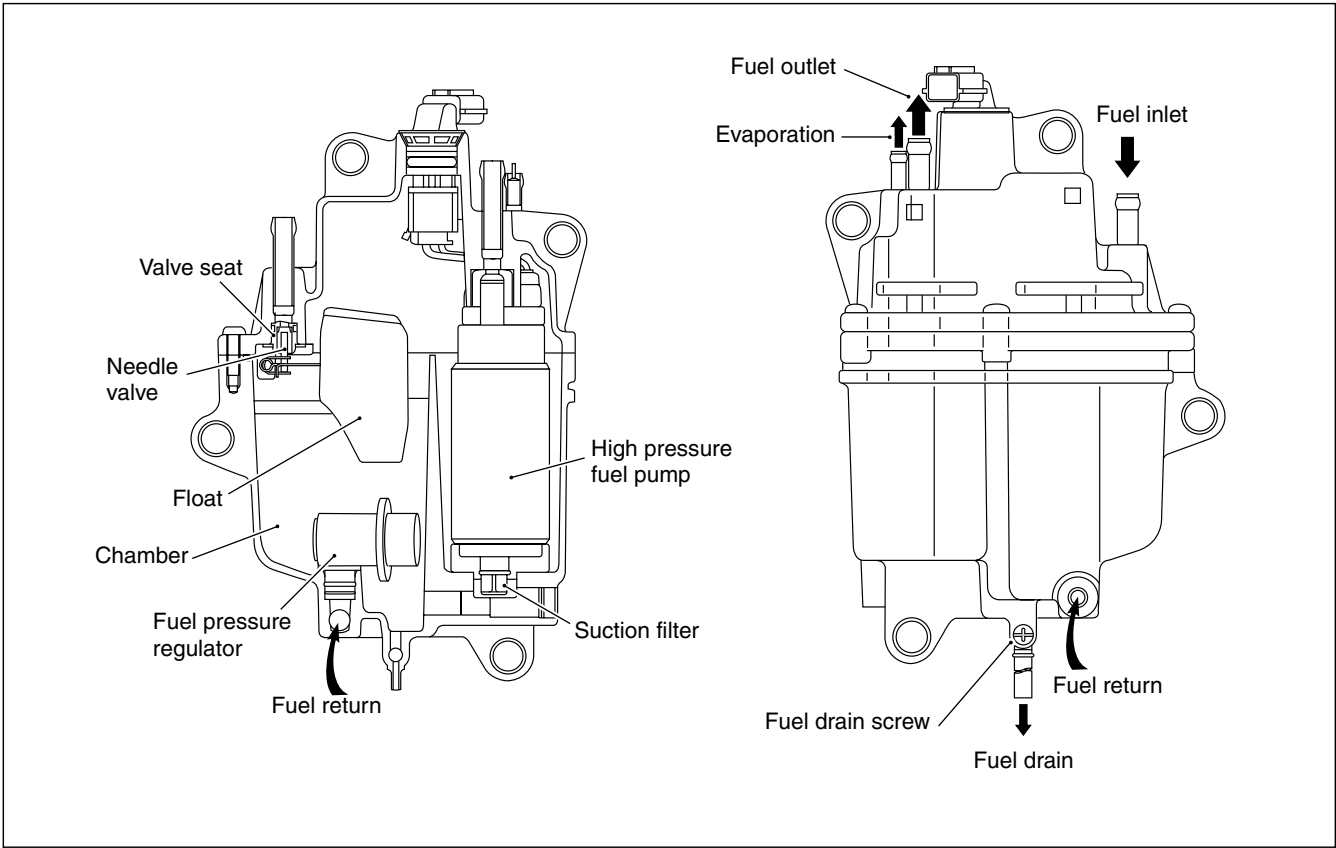

FUEL PRESSURE REGULATOR

The fuel pressure regulator is located in the fuel vapor separator.

The regulator's function in the system is to maintain a constant fuel pressure relative to the injector while the engine is operating.

The regulator diaphragm chamber is open to the fuel vapor separator chamber to keep the pressure balanced.

Fuel pressure, adjusted by the regulator, is constantly maintained higher than the pressure in the fuel vapor separator chamber by approx. 255 kPa (2.55 kg/cm², 36.3 psi).

By-pass fuel is returned back to the fuel vapor separator chamber.

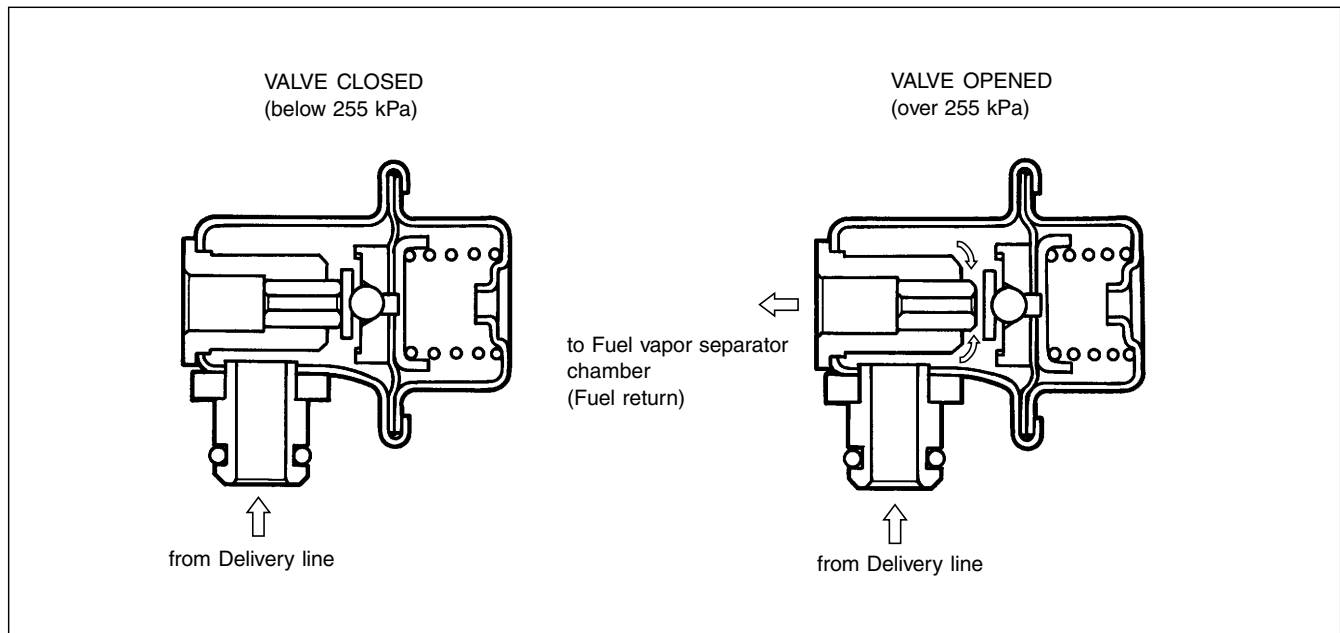

FUEL INJECTOR

The fuel injector is an electromagnetic valve operated by a signal from the ECM.

When the injection signal is supplied to the fuel injector, the solenoid coil is energized pulling up the plunger.

This opens the injector valve and injects fuel.

Because the fuel pressure is kept constant, the amount of fuel injected is determined by the amount of time (duration) the valve is open.

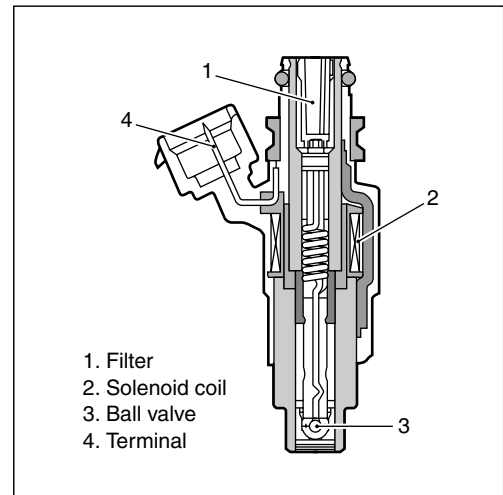

FUEL PUMP CONTROL SYSTEM

OUTLINE

To supply the optimum fuel amount, the ECM controls the fuel pump drive duty cycle, a repeated ON / OFF signal, at a specified rate (1000 times a second).
 Based on engine speed and battery voltage, the ECM determines the optimum duty (repeating "ON" time rate within a cycle) and sends this signal to the fuel pump.

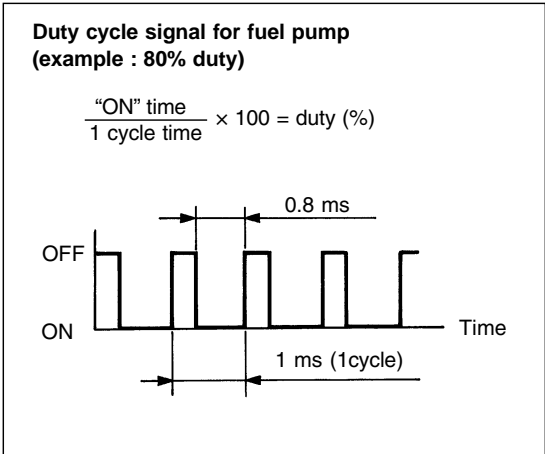
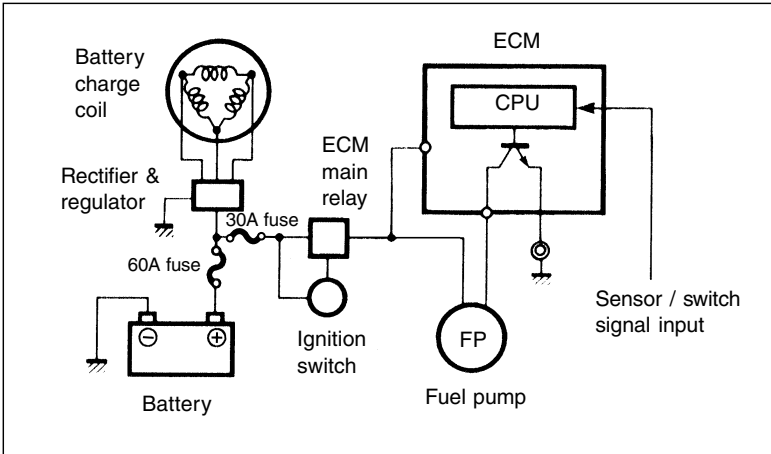
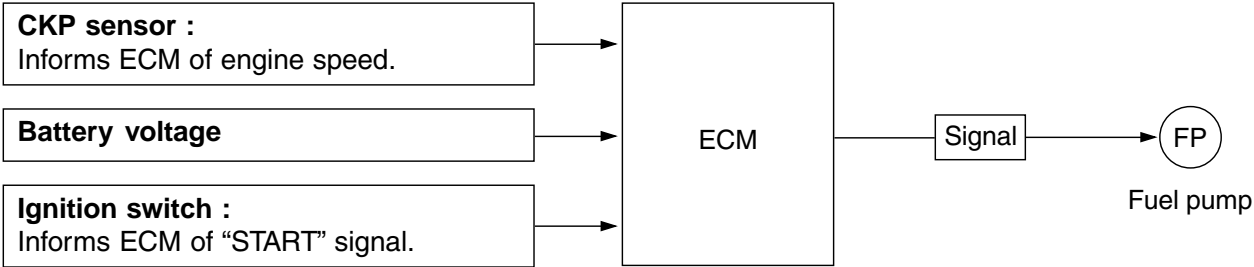

CONTROL MODE

BEFORE START :

For 3 seconds after ignition switch is turned "ON", the pump is controlled to operate at 100% duty in order to initially pressurize the high pressure line.

WHEN CRANKING :

The pump is controlled to operate at 100% duty.

WHEN RUNNING (NORMAL OPERATION) :

The pump is controlled to operate at 70 – 90% duty based on the current engine speed and battery voltage.

AIR INTAKE COMPONENTS

Air, after entering through the silencer, passes through the throttle body and flows into the surge tank where it is then distributed to the cylinder intake manifold.

Intake manifold pressure, monitored by the MAP sensor, is an indirect measure of the intake air amount. When the throttle is fully closed, the main supply of intake manifold air necessary to sustain engine idle passes through the by-pass air passage.

To maintain engine idle speed at specification, the ECM controlled IAC valve supplies a regulated amount of additional air through the IAC (idle air control) passage.

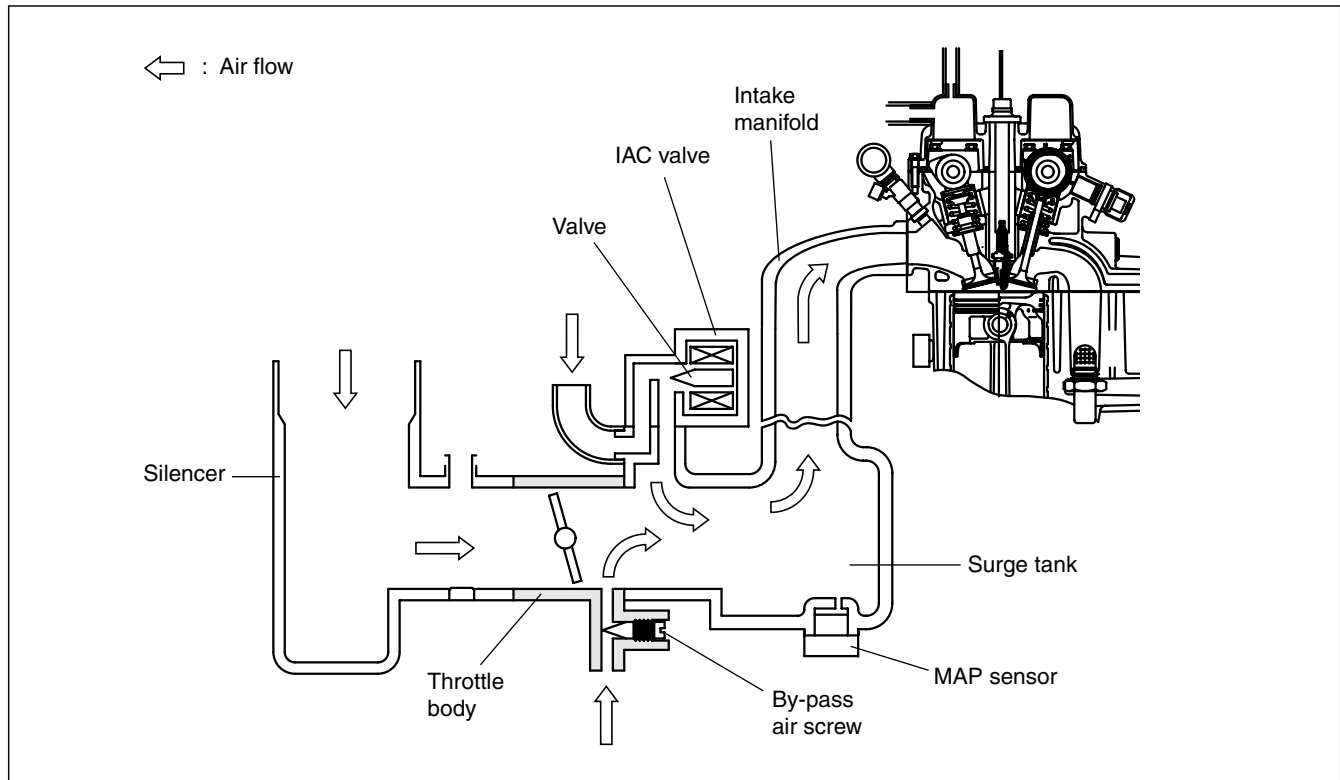

THROTTLE BODY

The throttle body assembly consists of the main bore, throttle valve, by-pass air passage, by-pass air screw and CTP switch. The throttle body adjusts the intake air amount with the throttle valve which is connected to the throttle / linkage lever. The CTP (closed throttle position) switch installed on the bottom of throttle body informs of throttle valve position.

NOTE:

Do not try to adjust or remove any of the throttle body component parts (CTP switch, throttle valve, throttle / linkage lever, etc.).

These components have been factory adjusted to precise specifications.

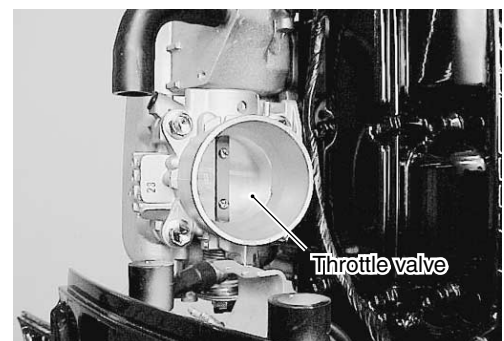
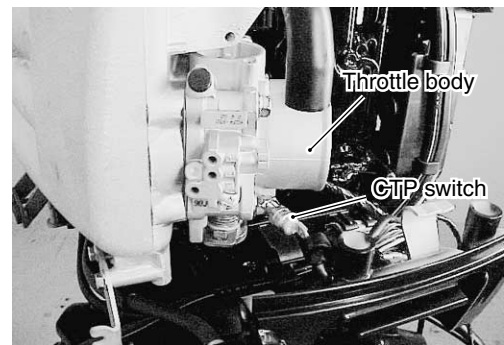

BY-PASS AIR SCREW / PASSAGE

Since the throttle valve is almost fully closed when idling / trolling, the main flow of air necessary to maintain idling / trolling speed passes through the by-pass air passage.

The by-pass air screw controls the flow of air through the passage and provides a means of partially adjusting the total amount of air necessary for idling / trolling.

NOTE:
See page 2-14 for the by-pass air screw adjustment procedure.

IAC VALVE / PASSAGE

The IAC valve is a linear solenoid plunger type mounted on the intake manifold.

Its purpose is to control the amount of intake air flowing from the IAC passage.

The IAC valve is driven by the duty cycle signal from the ECM.

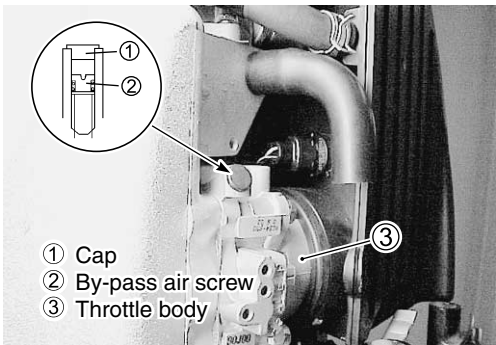

IDLE AIR CONTROL SYSTEM

OUTLINE

The ECM controls the duty cycle signal of the IAC valve to regulate a portion of the intake air flow to the intake manifold.

This system is used for the following purposes :

- To keep idling / trolling at specified speed.
- To improve driveability when decelerating.
(Dash-pot effect)
- To improve engine starting and warm-up performance.
(Fast-idle function)

The sensors / switch shown below monitor current engine condition and send signals to the ECM. Based on these signals, the ECM determines the optimum duty cycle (repeating "ON" time rate within a cycle).

A repeating ON / OFF signal at a specified rate (250 times a second) is then sent to the IAC valve.

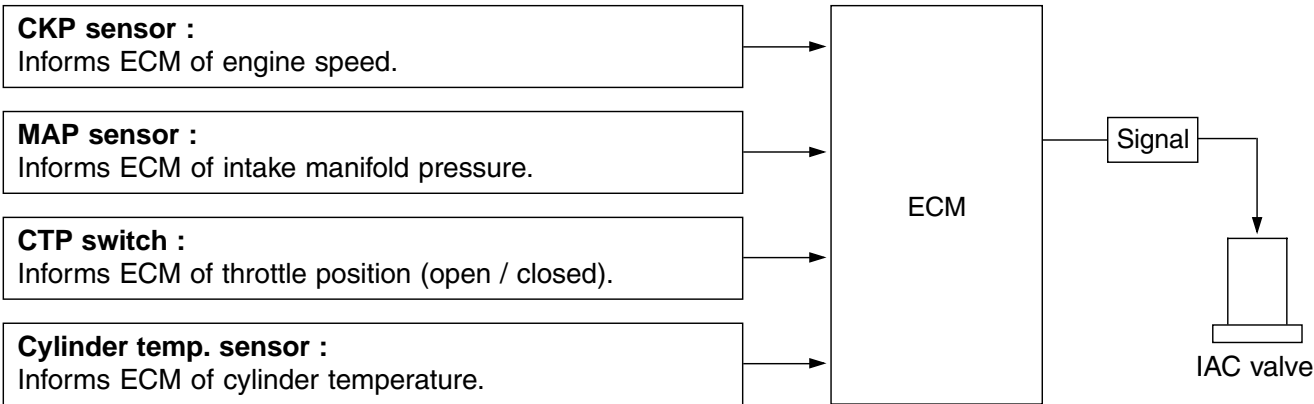

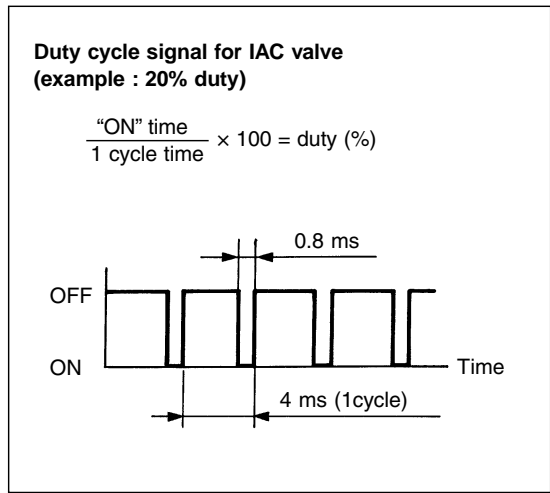
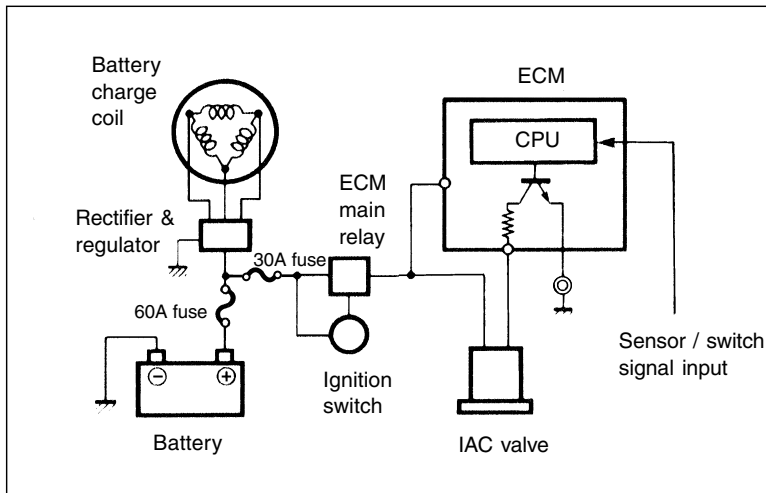

CONTROL MODE

BEFORE START :

The IAC valve is closed (0% duty) when engine is not running (but ignition switch is ON).

WHEN CRANKING :

The IAC valve is controlled to operate at approx. 80% duty.

AFTER START (FAST-IDLE FUNCTION) :

The IAC valve is controlled to operate at approx. 25 – 50% duty until the timer, which was set according to cylinder temperature at cranking, expires.

WHEN IDLING / TROLLING :

The IAC valve is controlled so that the engine speed is stable at the idling / trolling speed specified. During this period, the IAC valve has a duty cycle of approx. 15% but will vary slightly as idling / trolling conditions change.

WHEN RUNNING (NORMAL OPERATION) :

The IAC valve is controlled to operate at 20 – 50% duty, which depends on the current engine conditions.

WHEN DECELERATING (DASH-POT EFFECT) :

When the throttle valve is suddenly returned to full close and the CTP switch signal changes to “ON”, the IAC valve operates at a controlled gradual return to idle / troll operating duty to prevent engine stalling or unstable running.

NOTE:

Due to the limited intake air flow from the IAC passage and in order to effectively use both the “Dash-pot effect” and “Fast-idle function”, the by-pass air screw must be adjusted to provide IAC valve operation at approx. 15% duty at the engine idling / trolling specification.

See page 2-14 for the by-pass air screw adjustment procedure.

CAUTION SYSTEM

The following four caution systems alert the operator when an abnormality occurs on the engine.

- OVER-REVOLUTION CAUTION
- LOW OIL PRESSURE CAUTION
- OVERHEAT CAUTION
- LOW BATTERY VOLTAGE CAUTION

CAUTION TYPE	CAUTION LAMP	CAUTION BUZZER	OVER-REV LIMITER (3000 r/min.)
Over-revolution	Yes ①	No	Yes
Low oil pressure	Yes ②(①)	Yes	Yes
Overheat	Yes ③(①)	Yes	Yes
Low battery voltage	Yes ④	Yes	No

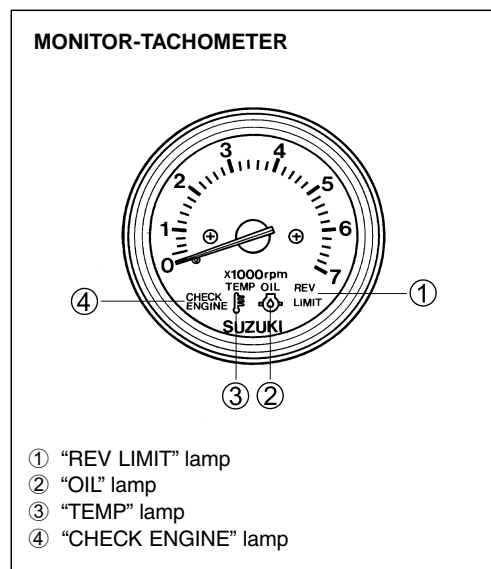

OVER-REVOLUTION CAUTION SYSTEM

CONDITION :

When the engine speed exceeds 6500 r/min., the ECM initiates intermittent fuel injection and ignition signals to provide a maximum engine speed of 6500 r/min. (Over-revolution limiter).

ACTION :

Engine speed	Automatically reduced to approx. 3000 r/min. by intermittent fuel injection and ignition signals.
Caution lamp	"REV-LIMIT" lamp lights continuously.
Caution buzzer	No buzzer sounds.

RESET :

Close throttle to reduce engine speed below approx. 3000 r/min. for one second.

LOW OIL PRESSURE CAUTION SYSTEM**CONDITION :**

Immediate activation of system when the oil pressure switch turns "ON" due to an engine oil pressure drop below 100 kPa (1.0 kg / cm², 14 psi.).

ACTION :

Engine speed	Automatically reduced to approx. 3000 r/min. by intermittent fuel injection and ignition signals if the system is activated at 3000 r/min. or higher.
Caution lamp	"OIL" lamp lights continuously. "REV-LIMIT" lamp lights continuously during engine speed rev-limiter activation.
Caution buzzer	Sounds in a series of long (1.5 sec.) beeps.

RESET :

Stop engine and check engine oil level. Refill engine oil to the correct level if below the low oil mark.

If the engine oil level is correct, the following causes may be considered :

- Improper oil viscosity.
- Malfunctioning oil pressure switch.
- Clogged oil strainer or oil filter.
- Worn oil pump relief valve.
- Oil leakage from oil passage.
- Excessive wear / damage of oil pump.

NOTE:

The low oil pressure caution system is reset when the oil pressure is restored to over 1.0 kg/cm² with approx. 3000 r/min. or less engine speed operation.

However, the engine must be stopped and checked immediately once the system is activated.

OVERHEAT CAUTION

CONDITION 1 (Maximum temperature)

Immediate activation of system when :

- Cylinder temperature reaches 121°C.
- Exhaust manifold temperature reaches 114°C.

CONDITION 2 (Temp. rise vs Time)

Immediate activation of system when :

- The average temperature difference during three consecutive 10 seconds measurement periods of the cylinder temperature sensor at engine speeds of 500 r/min. or higher exceeds the limits as shown below.

Temperature range	Temperature difference
86 °C ~ 99 °C	Approx. 2.2 °C
99 °C ~	Approx. 0.6 °C

- The average temperature difference during three consecutive 10 seconds measurement periods of the exhaust manifold temperature sensor at engine speeds of 500 r/min. or higher exceeds the limits as shown below.

Temperature range	Temperature difference
80 °C ~ 95 °C	Approx. 9.6 °C
95 °C ~	Approx. 1.4 °C

ACTION :

Engine speed	Automatically reduced to approx. 3000 r/min. by intermittent fuel injection and ignition signals if the system is activated at 3000 r/min. or higher.
Caution lamp	“TEMP” lamp lights continuously. “REV- LIMIT” lamp lights continuously during engine speed rev-limiter activation.
Caution buzzer	Sounds in a series of long (1.5 sec.) beeps.

RESET :

Close throttle to reduce engine speed below approx. 3000 r/min.

When cylinder temperature drops below the limits as shown below, the system resets. However, the system may be activated again unless the cause for overheat (such as insufficient water) is removed.

Caution cause	Reset temperature
Condition 1 (Maximum temperature)	Approx. 70 °C
Condition 2 (Temperature rise vs Time)	Approx. 65 °C

LOW BATTERY VOLTAGE CAUTION SYSTEM**CONDITION :**

System activated when battery voltage decreases to less than 9 volts for 30 seconds.

ACTION:

Engine speed	No engine speed limiter is activated.
Caution lamp	“CHECK ENGINE” lamp lights continuously.
Caution buzzer	Sounds in a series of long (1.5 sec.) beeps.

RESET:

This caution system is automatically reset when battery voltage increases to more than 9 volts. Refrain from using electrical equipment requiring high amperage such as hydraulic trim tabs, hydraulic jack plate, etc. after this caution is activated.

SELF-DIAGNOSTIC SYSTEM

The self-diagnostic system alerts the operator when an abnormality occurs in a signal from sensor, switch, etc.

When the system is activated, the "CHECK ENGINE" lamp flashes (lights intermittently) according to each code pattern along with a buzzer sound.

When engine is running, the buzzer sounds a series of short (0.2 sec.) beeps.

When engine is not running, the buzzer sounds according to each code pattern, but not simultaneous with the lamp flash.

The buzzer sound, activated by the self-diagnostic system, can be temporarily canceled by pushing the ignition key in.

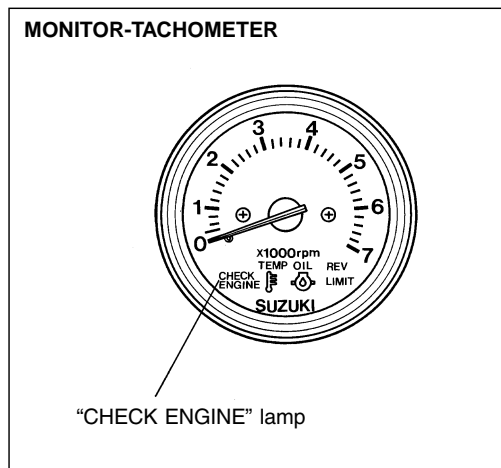

PRIORITY / CODE / PATTERN FOR SELF-DIAGNOSTIC SYSTEM OPERATION

PRIORITY	FAILED ITEM	CODE	LAMP FLASHING PATTERN	FAIL-SAFE SYSTEM ACTIVE
1	MAP sensor 1	3 - 4	on off	YES
2	CKP sensor	4 - 2	on off	YES
3	IAC valve / By-pass air screw adjustment	3 - 1	on off	NO
4	CMP sensor	2 - 4	on off	YES
5	CTP switch	2 - 2	on off	NO
6	Cylinder temp. sensor	1 - 4	on off	YES
7	IAT sensor	2 - 3	on off	YES
8	MAP sensor 2 (Pressure detect passage)	3 - 2	on off	NO
9	Rectifier & regulator (Over-charging) [NOTE1]	1 - 1	on off	NO
10	Exhaust manifold temp. sensor	1 - 5	on off	YES
11	Fuel injector	4 - 3	on off	NO

NOTE:

- *If more than two items fail at once, the self-diagnostic indication appears according to priority order. The indication repeats three times.*
- *If the failed item remains, the self-diagnostic indication appears again after turning the ignition switch "ON".*
- *After correcting failed item, the self-diagnostic indication appears until the ECM receives the proper signal with the engine running.*
- *For cylinder temp. sensor, exhaust manifold temp. sensor or IAT sensor the self-diagnostic indication will be canceled after corrective action by turning the ignition switch "ON".
(The ECM will require 10 – 20 seconds after turning the ignition switch "ON" to cancel the self-diagnostic indication.)*

NOTE 1 :

The self-diagnostic indication may be canceled by turning ignition switch "ON" because the ECM detects only battery voltage, not charging output. Under this condition the buzzer will not sound a 1-1 code. However, if the rectifier & regulator have failed, the self-diagnostic indication will again appear after starting the engine.

CONDITION FOR SELF-DIAGNOSTIC SYSTEM OPERATION

FAILED ITEM	CONDITION
MAP sensor 1	<ul style="list-style-type: none"> No signal (With engine running) Receiving an out of range “37–860 mmHg (0.20–4.53V)” signal (With engine running)
CKP sensor	<ul style="list-style-type: none"> During one crankshaft rotation, 34 signals are not input to the ECM
IAC valve / By-pass air screw adjustment	<ul style="list-style-type: none"> IAC valve operates at 90% duty or higher when CTP switch is “ON” [NOTE 1]
CMP sensor	<ul style="list-style-type: none"> During two crankshaft rotations, 4 signals are not input to the ECM
CTP switch	<ul style="list-style-type: none"> Receiving “ON” signal when engine speed is 2500 r/min. or higher and intake manifold pressure is 319 mmHg or higher
Cylinder temp. sensor	<ul style="list-style-type: none"> No signal Receiving an out of range “– 46 to +170 °C (0.10 – 4.63V)” signal
IAT sensor	<ul style="list-style-type: none"> No signal Receiving an out of range “– 46 to +178 °C (0.04 – 4.46V)” signal
MAP sensor 2 (Pressure detect passage)	<ul style="list-style-type: none"> Receiving unchanging signal regardless engine speed change [NOTE 2]
Rectifier & regulator (Over-charging)	<ul style="list-style-type: none"> Receiving 16 volts or higher signal
Exhaust manifold temp. sensor	<ul style="list-style-type: none"> No signal Receiving an out of range “– 46 to +170 °C (0.10 – 4.63V)” signal
Fuel injector	<ul style="list-style-type: none"> No operation signal from the ECM

NOTE 1:

These conditions will be caused by IAC valve failure or incorrect by-pass air screw adjustment. If IAC valve is always closed or by-pass air is too low, the ECM controls the IAC valve duty to increase to maintain the idling / trolling speed specified.

NOTE 2:

This condition will be caused by clogged pressure detect passage in intake manifold.

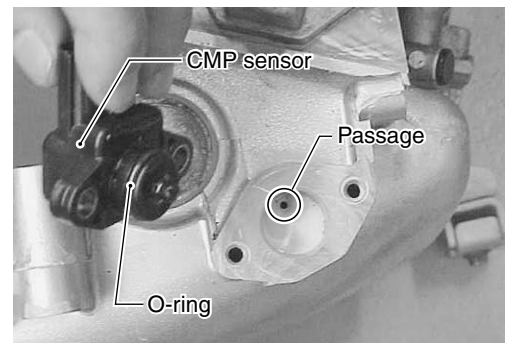

FAIL-SAFE SYSTEM

The fail-safe system is closely related to the self-diagnostic system.

When an abnormality occurs in a sensor signal, the ECM ignores the out-of-range signal and assumes a pre-programmed value for the failed sensors.

This allows the engine to continue running under the fail-safe condition.

PRE-PROGRAMMED VALUE FOR FAIL-SAFE SYSTEM

FAILED ITEM	PRE-PROGRAMMED VALUE
MAP sensor 1	• 319 – 475 mmHg / (Correspond to approx. 750 – 4000 r/min.) [NOTE 1]
CKP sensor	Based on signals from CMP sensor : <ul style="list-style-type: none"> • Ignition timing fixed at BTDC 5° • Normal sequential fuel injection
CMP sensor	Based on signals from CKP sensor : (a) Failed while engine running <ul style="list-style-type: none"> • Ignition timing fixed at BTDC 5° • Normal sequential fuel injection (b) Failed prior to engine start <ul style="list-style-type: none"> • Ignition timing fixed at BTDC 5° • 1 simultaneous injection for all cylinders per 2 crankshaft rotations
Cylinder temp. sensor	60 °C (140 °F)
IAT sensor	45 °C (113 °F)
Exhaust manifold temp. sensor	60 °C (140 °F)

NOTE:

There is no back-up system for the ECM itself. The engine will stop if it has failed.

NOTE 1:

This value will change according to the current engine speed.

OPERATING HOUR INDICATION SYSTEM

When the ignition switch is initially turned “ON” (from “OFF”), the ECM tests the caution system by turning on all four lamps in the monitor-tachometer and sounding the caution buzzer for an initial two seconds.

For the next three seconds, the ECM indicates the total operating hours, using a combination of the tachometer needle and “REV-LIMIT” lamp flashing.

NOTE:

The total operating hours displayed are those of actual engine operation, not ignition switch “ON” time.

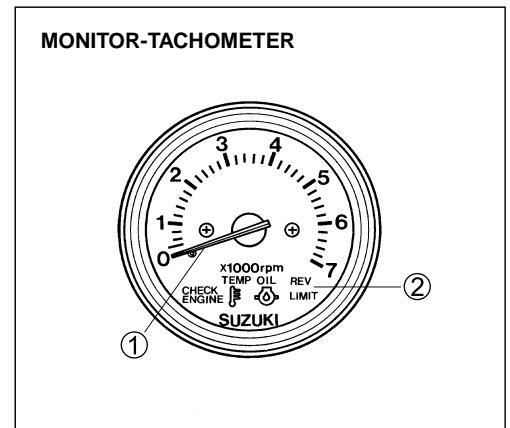

CHART OF TOTAL OPERATING HOURS INDICATION

Total operating hours	MONITOR-TACHOMETER	
	Needle ① indication	REV-LIMIT lamp ② flashing *
0 h – (49 h)	No	No
50 h	500 rpm	
60 h	600 rpm	
⋮	⋮	
540 h	5400 rpm	
550 h	500 rpm	1 time
560 h	600 rpm	
⋮	⋮	
1040 h	5400 rpm	2 times
1050 h	500 rpm	
⋮	⋮	
1540 h	5400 rpm	3 times
1550 h	500 rpm	
⋮	⋮	
2030 h	5300 rpm	3 times
2040 h or over	5400 rpm	

* : One flashing is corresponded to 500 hours.

OIL CHANGE REMINDER SYSTEM

This system informs the operator of the time for replacing ENGINE OIL on the basis of the recommended maintenance schedule. When the total motor operating hours have reached the preprogrammed hours, the "OIL" lamp will flash, and the buzzer will begin a series of double beeps if engine is not running (but ignition switch is ON). The above mentioned indication will repeat until canceling system activation.

NOTE:

This system will activate up to 2100 hour's operation.

INDICATION OF SYSTEM ACTIVATION

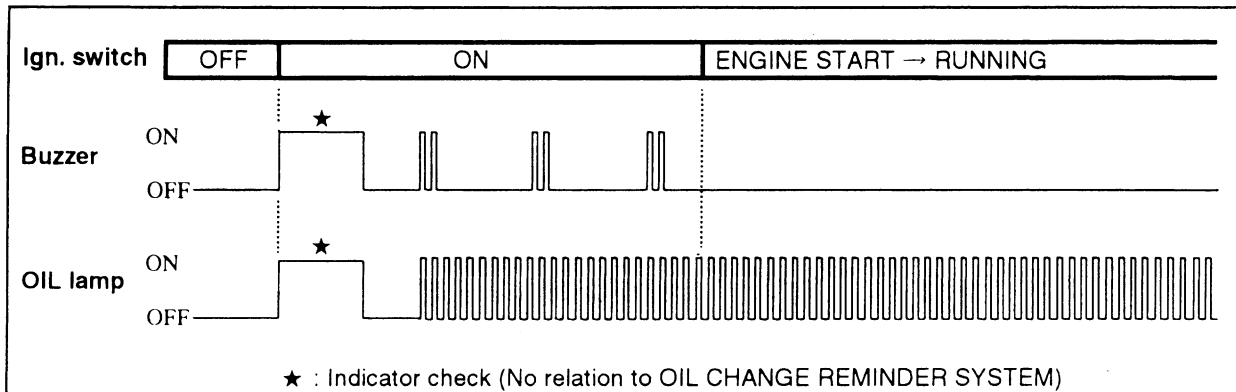
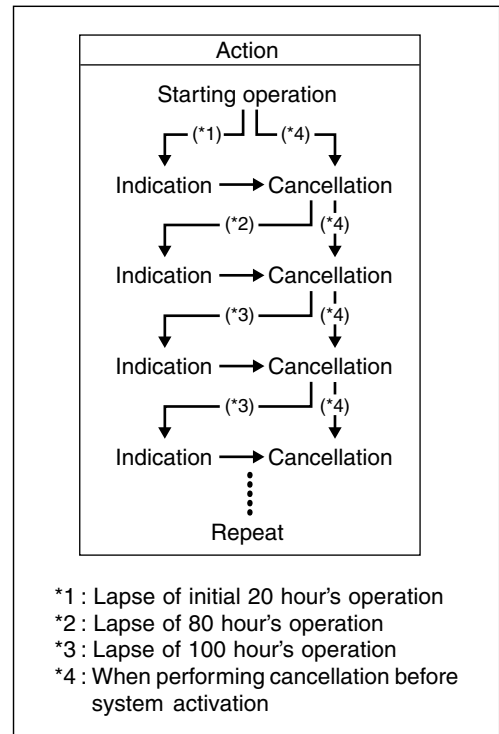
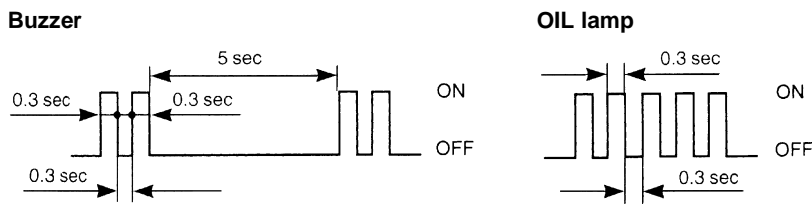

CANCELLATION

Procedure

1. Turn ignition key to "ON" position.
2. Pull out emergency stop switch plate ①.
3. Pull up emergency stop switch knob ② three times in seven seconds. A short beep will be heard if cancellation is successfully finished.
4. Turn ignition key to "OFF" position.
5. Set switch plate ① in original position.

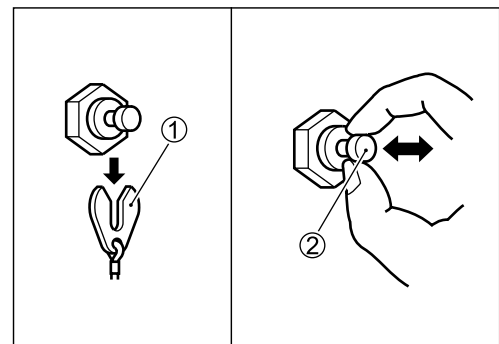

NOTE:

- *Canceling of the system activation is possible regardless of whether or not the engine oil has been replaced. Once the system has operated, however, Suzuki strongly recommends that the engine oil be replaced before canceling the system activation.*
- *Even if the engine oil has been replaced with the system not operating, it is still necessary to perform the cancellation.*

START-IN-GEAR PROTECTION SYSTEM

A switch to detect neutral gear position is located on the cylinder block (STBD side) and operated by the clutch control lever.

This ON / OFF type switch is “ON” in neutral and “OFF” in forward or reverse.

On starting the engine, the ECM detects the shift position using the neutral switch. When the neutral switch is “OFF”, the ECM does not provide injector operating signal.

This neutral switch is also used to regulate the starter motor circuit.

The engine will not start, even by emergency rope, with the shift in the forward or reverse position.

SHIFT POSITION	NEUTRAL SWITCH	OPERATION			
		Fuel injector	Ignition	Fuel pump	Starter motor
Neutral	ON	Yes	Yes	Yes	Yes
Forward / Reverse	OFF	No	Yes	Yes	No

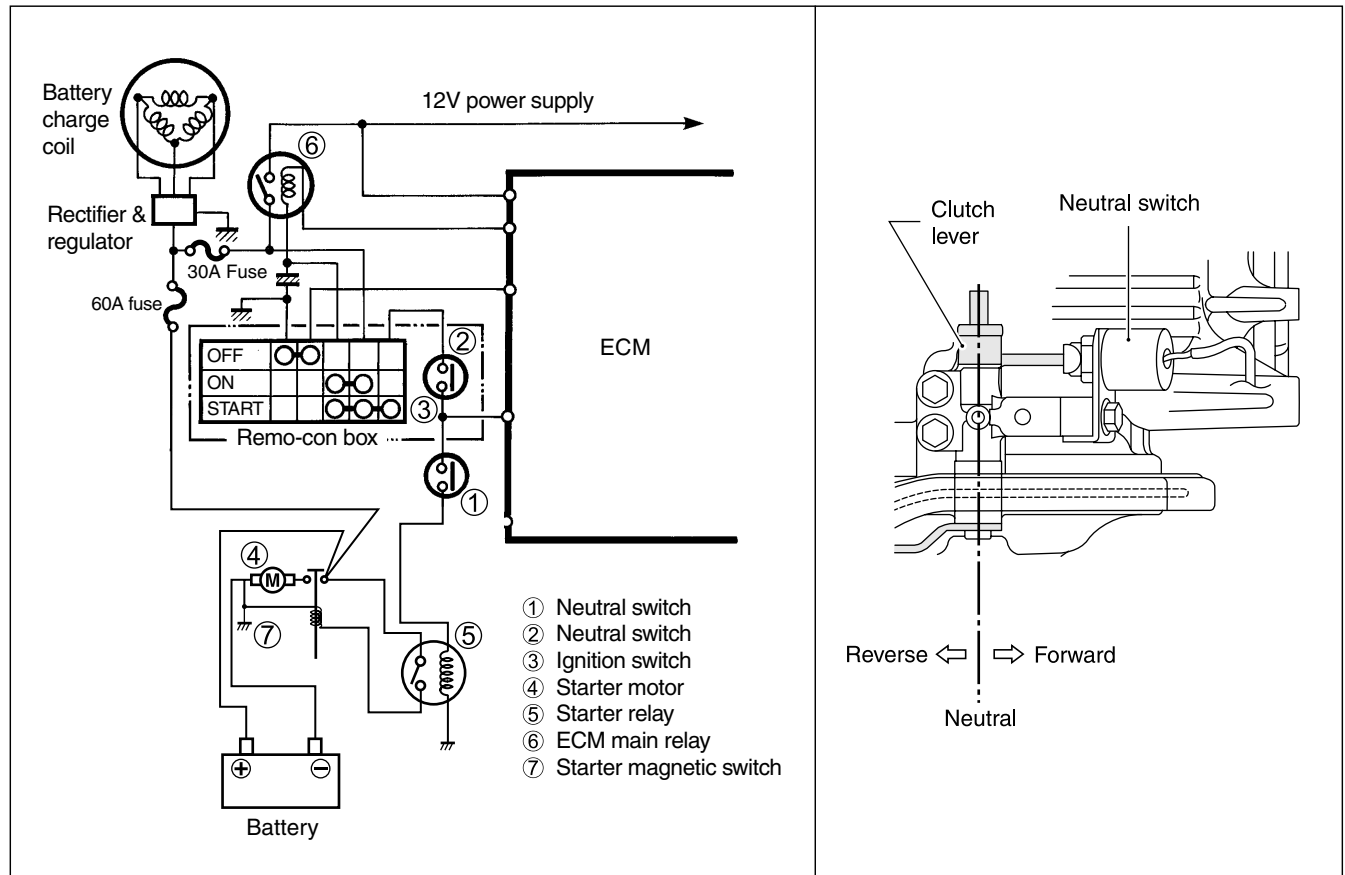

O₂ FEEDBACK SYSTEM

After extended usage, engine components may become deteriorated or worn out.

This might make the A/F (air / fuel mixture ratio) incorrect which could affect exhaust emissions. To correct the A/F, an O₂ sensor must be temporarily installed in the exhaust manifold. This sensor is used to measure the concentration of oxygen in the exhaust gas at engine speeds of 2000, 3000 and 4000 r/min.

The ECM uses the input data from the O₂ sensor to correct the compensation coefficient of the fuel injection duration map within the ECM itself.

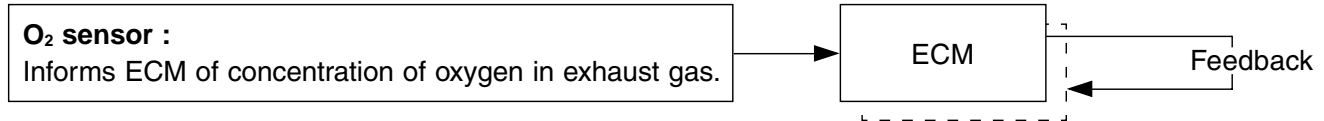

 **18213-74F00 : O₂ sensor**

NOTE:

For fuel mixture check (O₂ feedback) operation procedure, refer to "Suzuki Diagnostic System Operation Manual".

INSPECTION

PRECAUTION ON SYSTEM INSPECTION

⚠ WARNING

To prevent any unexpected engine start, perform the following before proceeding with any **CRANKING** tests.

- When performing tests not related to fuel injector operation :
 - Disconnect all fuel injector wire connectors.
- When performing tests related to fuel injector operation :
 - Relieve fuel pressure in line. (See page 5-3)
 - Disconnect high pressure fuel pump wire connector located on fuel vapor separator.

CAUTION

- Always turn ignition switch "OFF" and disconnect battery cables when wires are being disconnected or connected.
- Hold and pull connector pieces when disconnecting. Do not pull wires.

NOTE:

- Self-diagnostic codes will remain in ECM memory even if battery is disconnected.
- As each terminal voltage is affected by battery voltage, use a full-charged battery.
- Make sure all ground points have good electrical contact.
- Make sure all wires / cables are securely connected.

44-PIN TEST CORD

This test cord is used when checking the circuit for voltage, etc. and connected between ECM and the wiring harness.

To measure, connect the tester probe to the relevant terminal of the test cord.

 **09930-89950 : 44-pin test cord**

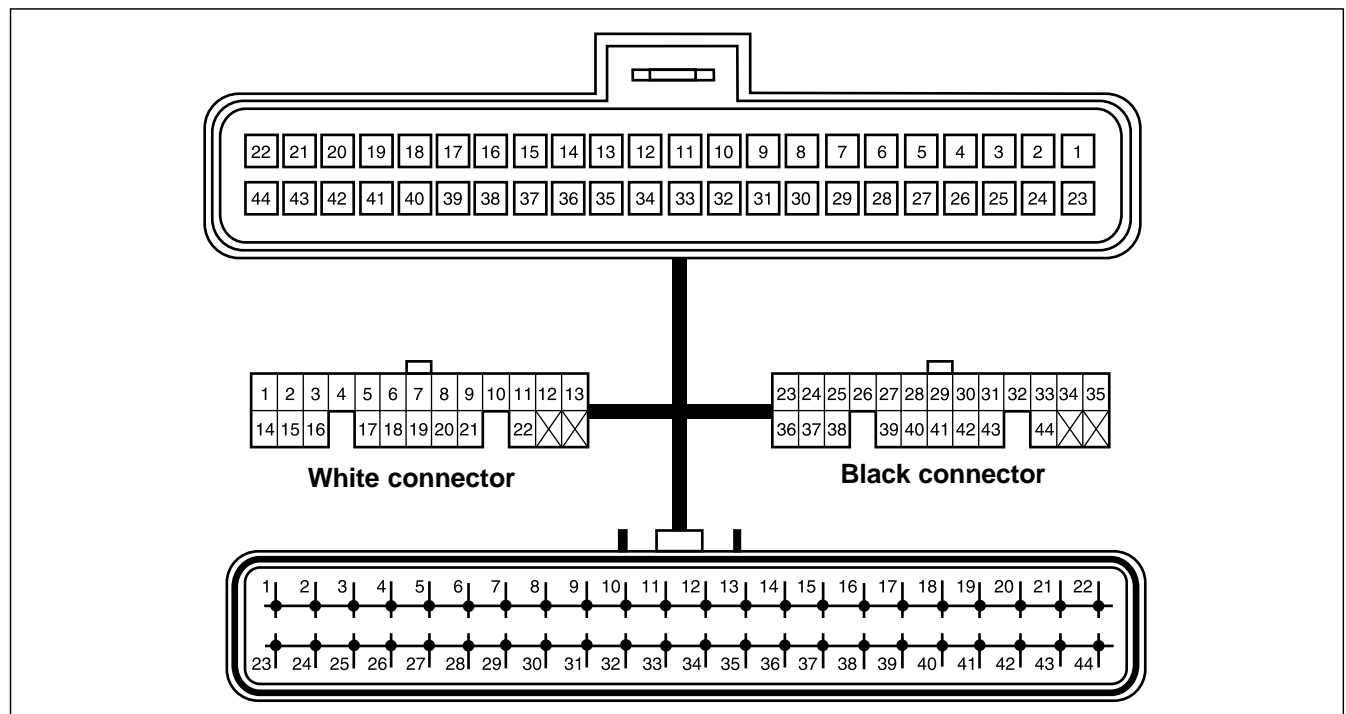

INSPECTION FOR ECM CIRCUIT VOLTAGE

CAUTION

ECM cannot be bench checked. It is strictly prohibited to connect any tester (voltmeter or ohmmeter) to an ECM separated from the engine wiring harness.

TOOL 09930-89950 : 44-pin test cord
09930-99320 : Digital tester

DCV Tester range : --- V (DC voltage)

1. Connect 44-pin test cord between ECM and wire harness as shown in figure.
2. Turn ignition switch ON.
3. Connect the tester probe \ominus (Black) to body ground, and measure voltage according to "CIRCUIT VOLTAGE TABLE".

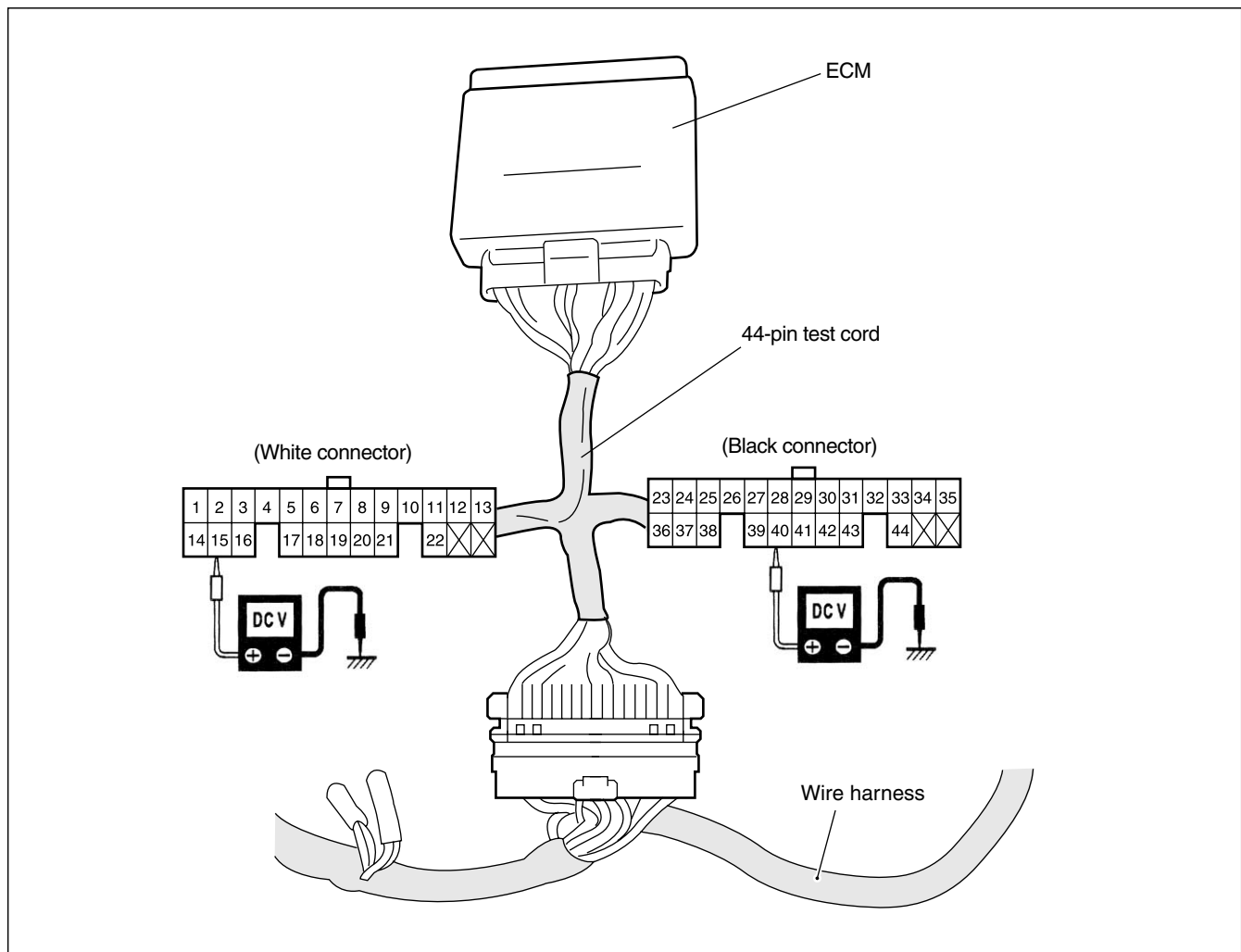

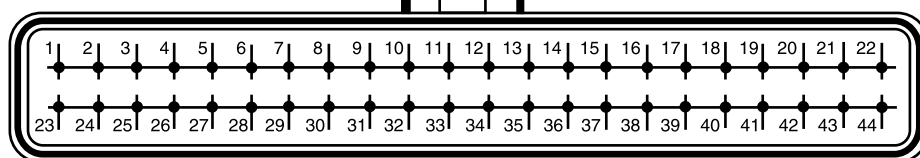

CIRCUIT VOLTAGE TABLE

TER-MINAL	WIRE COLOR	CIRCUIT	STANDARD VOLTAGE	CONDITION / REMARKS
1	—	—	—	—
2	Bl/R	Emergency stop switch	Approx. 5V	Ignition switch ON, stop switch plate IN
			Approx. 0V	Ignition switch ON, stop switch plate OUT
3	O	Buzzer cancel	Approx. 12V	Ignition switch ON, key pushed in
			Approx. 0V	Ignition switch ON, key not pushed in
4	Y/B	Tachometer	—	—
5	Br	Neutral switch	Approx. 0V	Ignition switch ON, shift in NEUTRAL
			Approx. 2.5V	Ignition switch ON, shift in FORWARD or REVERSE
			6 – 12V	While engine cranking.
6	—	—	—	—
7	V/W	Ex-manifold temp. sensor	0.10 – 4.63V	Ignition switch ON
8	—	—	—	—
9	Lg/W	Cylinder temp. sensor	0.10 – 4.63V	Ignition switch ON
10	B	Ground for ECM	—	—
11	B/W	Ground for sensors	—	—
12	Bl/B	Oil lamp	—	—
13	P/B	Ground for ECM main relay	—	—
14	—	—	—	—
15	R/B	CKP sensor	—	—
16	O/Y	PC communication	—	—
17	G/Y	TEMP lamp	—	—
18	B/R	IAC valve solenoid (–)	Approx. 12V	Ignition switch ON
19	—	—	—	—
20	B	Ground for ignition coil	—	—
21	—	—	—	—
22	Lg	No.4 Fuel injector (–)	Approx. 12V	Ignition switch ON
23	Bl	Oil pressure switch	Approx. 5V	Engine running
			Approx. 0V	Engine stopped (Ignition switch ON)
24	Lg/R	CTP switch	Approx. 12V	Ignition switch ON, throttle open (any position)
			Approx. 0V	Ignition switch ON, throttle fully closed
25	P	REV-LIMIT lamp	—	—
26	G/W	CHECK ENGINE lamp	—	—
27	Bl/W	Buzzer	—	—
28	—	—	—	—
29	W	MAP sensor	0.20 – 4.53V	Ignition switch ON
30	Gr	ECM power source	Approx. 12V	Ignition switch ON
31	Lg/B	IAT sensor	0.04 – 4.46V	Ignition switch ON
32	B	Ground for ECM	—	—
33	O/G	CMP sensor	Approx. 0.3V or 5V	Ignition switch ON
34	B/G	O ₂ feedback / PC communication	—	—
35	R	Power source for MAP sensor	Approx. 5V	Ignition switch ON
36	Y	PC communication	—	—
37	B/W	Fuel pump (–)	Approx. 0V	For 3 sec. after ignition switch ON Engine running
			Approx. 12V	Engine stopped (Ignition switch ON)
38	R/W	No.3 Fuel injector	Approx. 12V	Ignition switch ON
39	B/Y	No.2 Fuel injector injeccortor	Approx. 12V	Ignition switch ON
40	O/B	No.1 Fuel injector	Approx. 12V	Ignition switch ON
41	—	—	—	—
42	B	Ground for ignition coil	—	—
43	Bl	No.2 Ignition (–)	Approx. 12V	Ignition switch ON
44	O	No.1 Ignition (–)	Approx. 12V	Ignition switch ON



INSPECTION FOR RESISTANCE

 09930-99320 : Digital tester

 Tester range : Ω (Resistance)

NOTE:

Make sure ignition switch is always OFF when measuring resistance.

1. Disconnect battery cables from battery.
2. Disconnect wire harness connector from ECM.
3. Connect the tester probes to terminal (wire harness side), and measure resistance according to “RESISTANCE TABLE”.

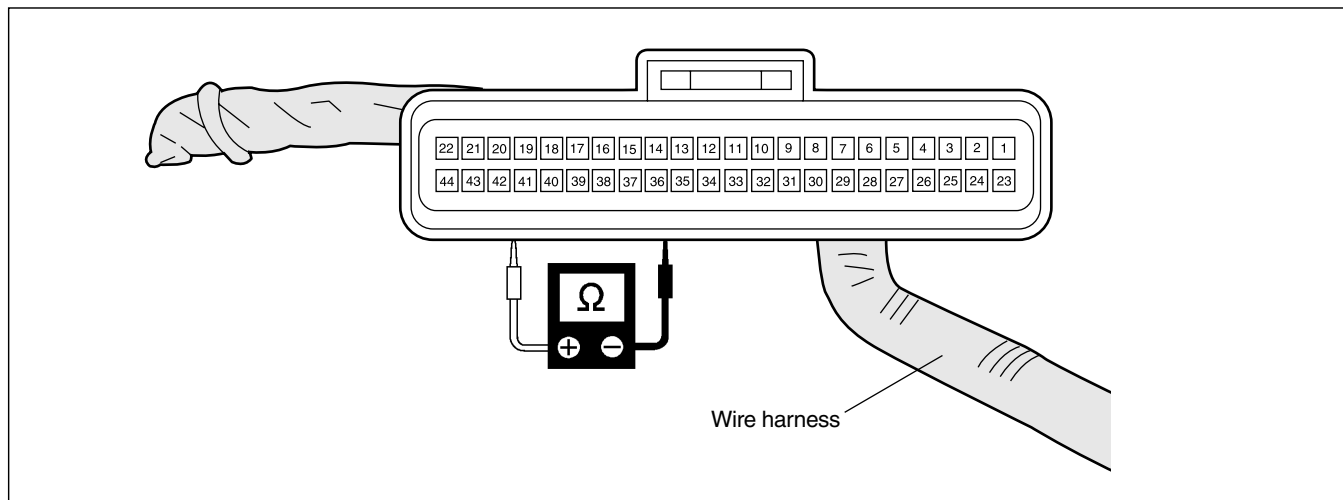

RESISTANCE TABLE

ITEM	TERMINAL FOR TESTER PROBE CONNECTION	STANDARD RESISTANCE (at 20°C)
CKP sensor	15 (R/B) to 11(B/W)	168 – 252 Ω
Ignition coil No.1&4 (Primary)	30 (Gr) to 44 (O)	1.9 – 2.5 Ω
Ignition coil No.2&3 (Primary)	30 (Gr) to 43 (Bl)	
Fuel injector No.1	30 (Gr) to 40 (O/B)	11.0 – 16.5 Ω
Fuel injector No.2	30 (Gr) to 39 (B/Y)	
Fuel injector No.3	30 (Gr) to 38 (R/W)	
Fuel injector No.4	30 (Gr) to 22 (Lg)	
IAC valve	30 (Gr) to 18 (B/R)	8 – 12 Ω
IAT sensor	31 (Lg/B) to 11 (B/W)	0°C (32°F) : 5.3 – 6.6 k Ω 25°C (77°F) : 1.8 – 2.3 k Ω 50°C (122°F) : 0.73 – 0.96 k Ω 75°C (135°F) : 0.33 – 0.45 k Ω (Thermistor characteristic)
Cylinder temperature sensor	9 (Lg/W) to 11 (B/W)	
Ex-mani. temperature sensor	7 (V/W) to 11(B/W)	
ECM main relay	13 (P/B) to Terminal (A) [NOTE1]	80 – 120 Ω

NOTE1:

Disconnect remote control wire harness, and connect tester probe to terminal ① (Gray wire).

COMPONENT INSPECTIONS

FUEL PUMP 3 SEC. OPERATING SOUND

Turn ignition switch ON and check for fuel pump operating sound.

Fuel pump operating sound :

Sounds for approx. 3 seconds only

NOTE:

Fuel pump operating sound is low because pump is in fuel vapor separator. If you cannot hear pump sound clearly, use a sound scope or long blade screw driver.

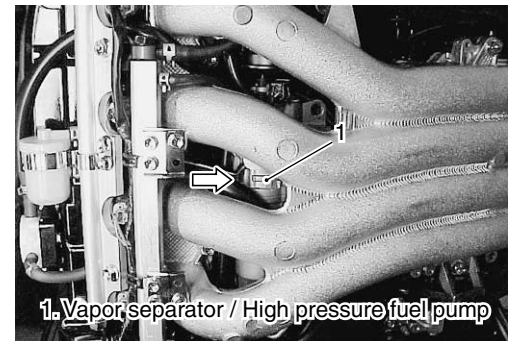
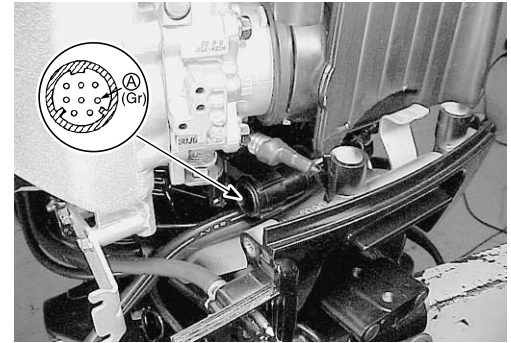

FUEL INJECTOR OPERATING SOUND (CRANKING)

1. Touch a sound scope or long blade screw driver to fuel injector body as shown.
2. Crank engine and check for injector operating sound.

Injector operating sound : "Click"

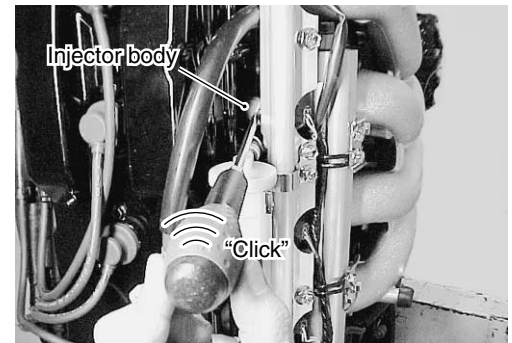

FUEL INJECTOR OPERATING SOUND (INDIVIDUAL)

1. Disconnect fuel injector wire, and connect the test cord.

TOOL 09930-89260 : Injector test cord A

2. Connect Gray wire to body ground.
3. Momentarily touch Black/Yellow wire to starter motor magnetic switch "B" terminal (connected to battery positive ⊕ terminal), and check for injector operating sound.

Injector operating sound : "Click"

CAUTION

Connecting fuel injector to battery positive for more than a few seconds may cause injector overheating and possible injector solenoid failure.

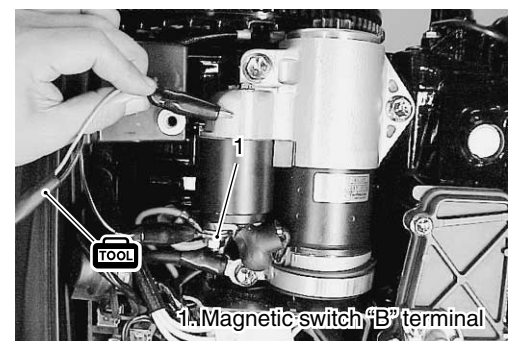
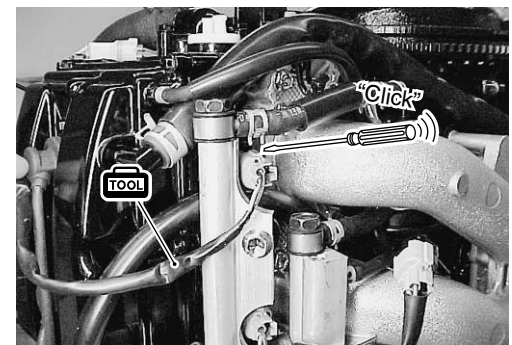

FUEL INJECTOR OPERATING SIGNAL

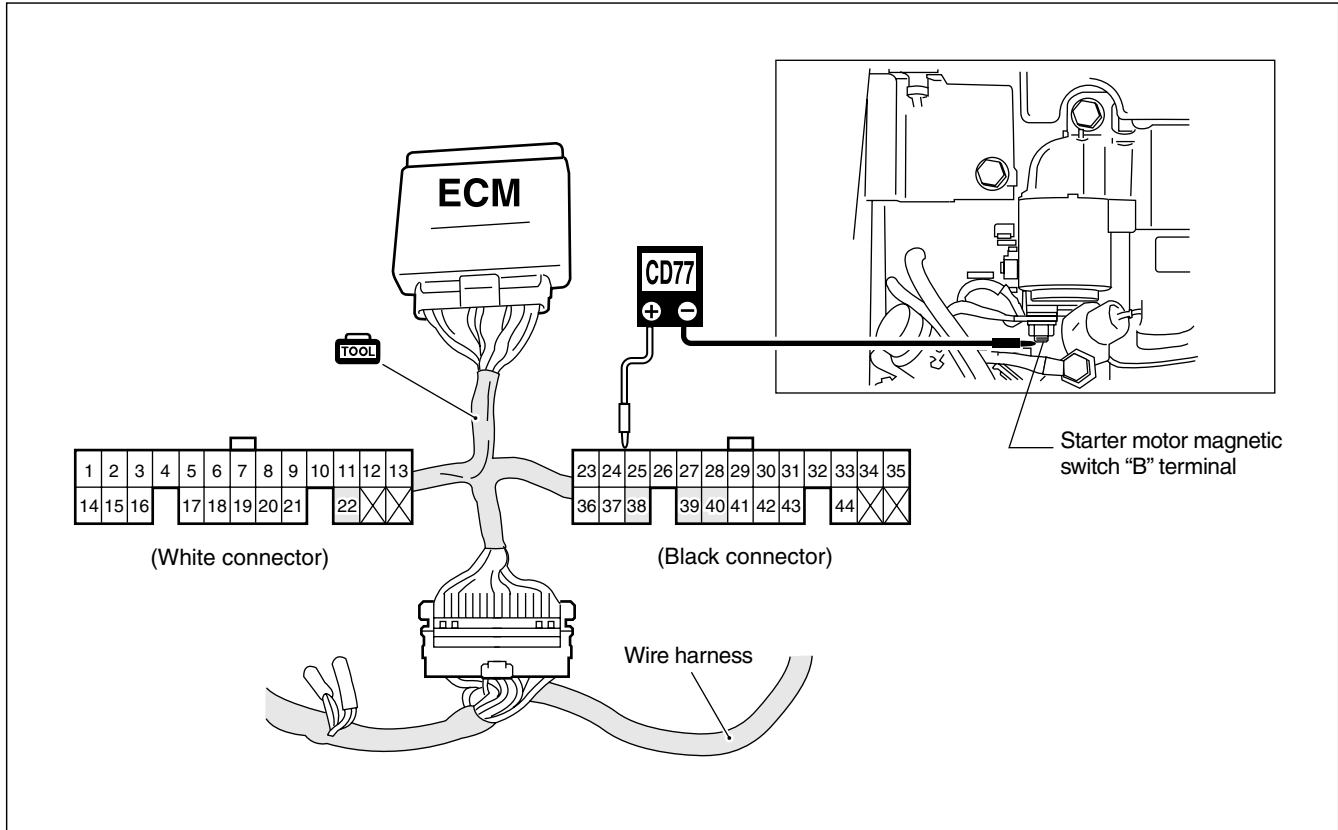

09930-89950 : 44-pin test cord

Peak voltmeter Stevens CD-77

Tester range : NEG50

1. Connect test cord between ECM and wire harness as shown in figure, then turn ignition switch ON.
2. Connect tester probe ⊖ (Black) to starter motor magnetic switch “B” terminal (connected to battery positive ⊕ terminal) as shown in figure.
3. Connect tester probe ⊕ (Red) to each terminal.

Injector	Terminal
No.1	40
No.2	39
No.3	38
No.4	22

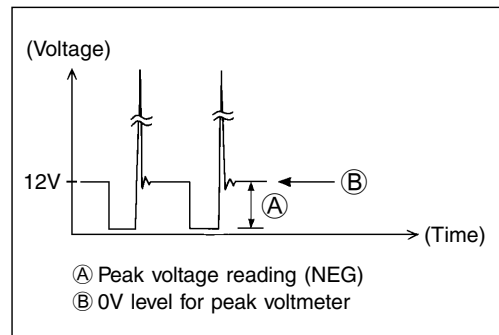

4. Crank engine and measure voltage.
Fuel injector operating signal : 6 – 10 V

IGNITION COIL OPERATING SIGNAL

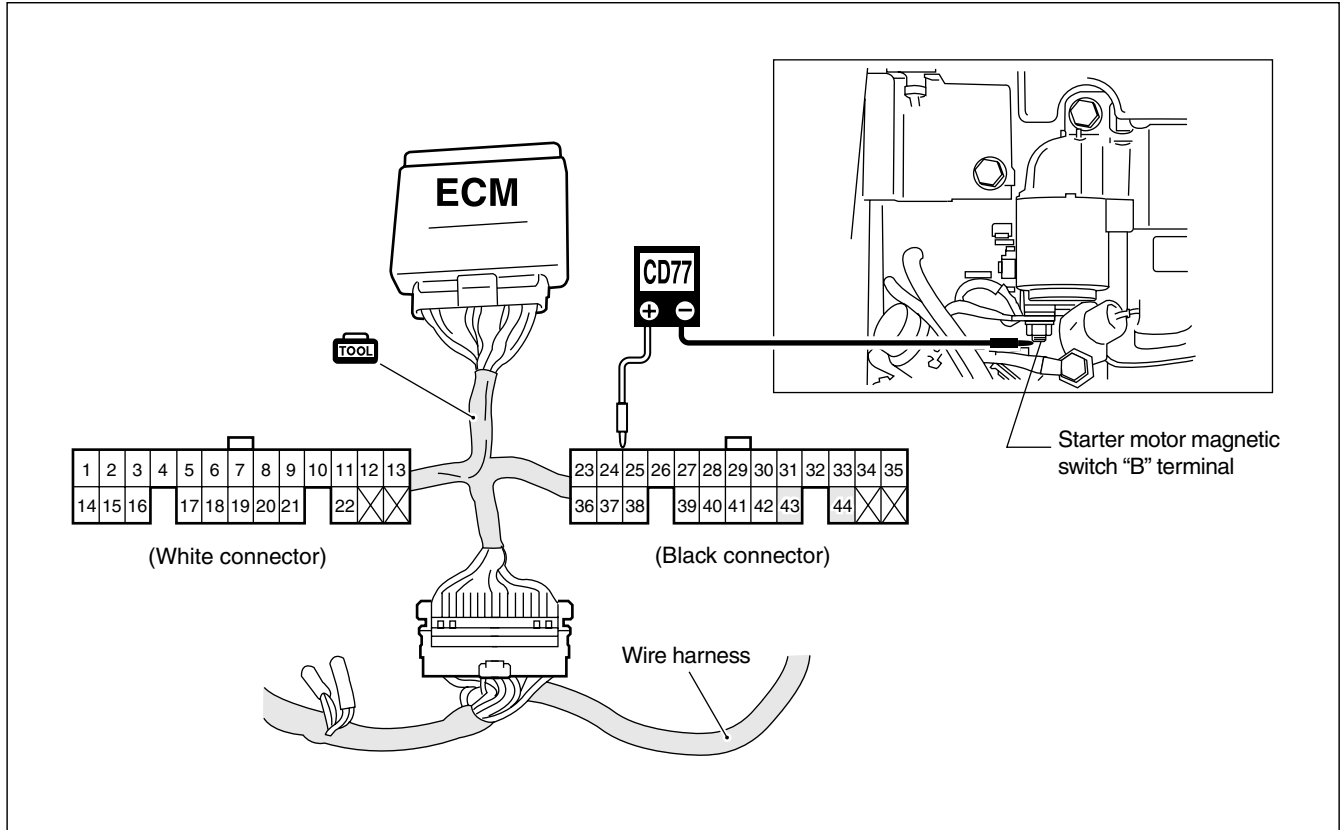

TOOL 09930-89950 : 44-pin test cord

CD77 Peak voltmeter Stevens CD-77
 Tester range : NEG50

1. Connect test cord between ECM and wire harness as shown in figure, then turn ignition switch ON.
2. Connect tester probe ⊖ (Black) to starter motor magnetic switch "B" terminal (connected to battery positive ⊕ terminal) as shown in figure.
3. Connect tester probe ⊕ (Red) to each terminal.

Ignition coil	Terminal
No.1 & 4	44
No.2 & 3	43

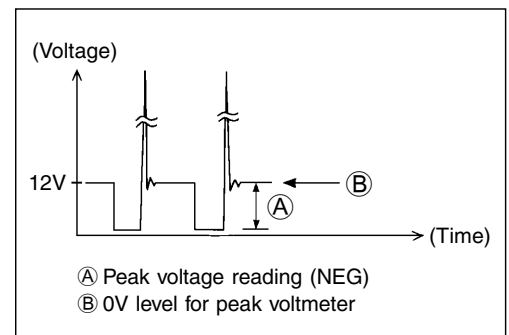

4. Crank engine and measure voltage.
Ignition coil operating signal : 6 – 10 V

IGNITION SECONDARY COIL RESISTANCE

 **09930-99320 : Digital tester**

 **Tester range : Ω (Resistance)**

1. Disconnect spark plug caps from spark plugs.
2. Measure resistance between both spark plug caps as shown in figure.

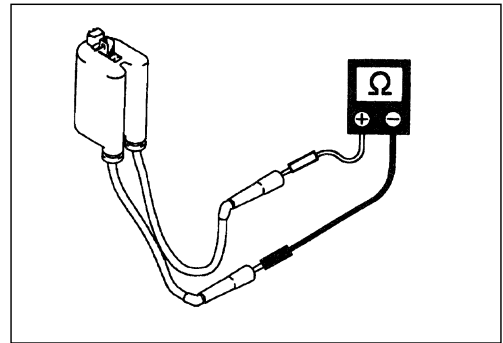

Ignition secondary coil resistance :

No. 2&3 18 – 34 k Ω

No. 1&4 19 – 36 k Ω

CMP SENSOR SIGNAL

 **09930-89950 : 44-pin test cord**

09930-99320 : Digital tester

 **Tester range : --- V (DC voltage)**

1. Remove CMP sensor. (See page 3-53.)
2. Connect 44-pin test cord between ECM and wire harness as shown in figure.
3. Connect tester probe \oplus (Red) to No.33 terminal.
4. Connect tester probe \ominus (Black) to No.11 terminal (or to body ground).
5. Turn ignition switch ON.
6. Measure voltage when steel tip of a screwdriver is brought near and then pulled away from sensor tip.

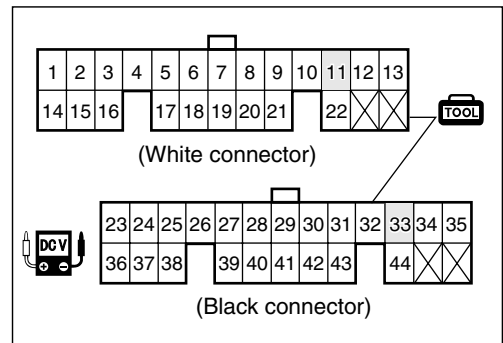
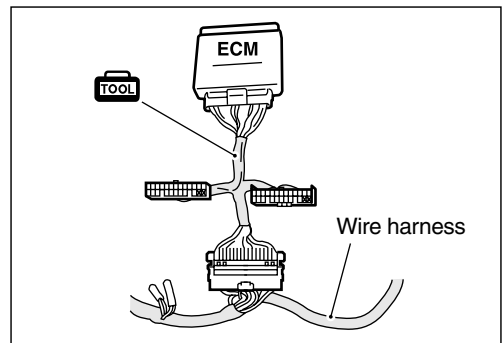

CMP sensor signal : Approx. 0.3V or 5V

NOTE:

Two signal voltages mentioned above (0.3V or 5V) will change by repeating movement of screwdriver.

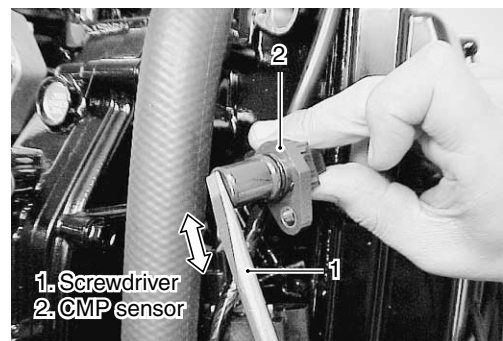

MAP SENSOR OUTPUT VOLTAGE CHANGE

-  **09917-47011 : Vacuum pump gauge**
- 09930-89950 : 44-pin test cord**
- 09930-99320 : Digital tester**

 **Tester range : $\overline{\text{---}}$ V (DC voltage)**

1. Remove bolts and MAP sensor from intake manifold.
2. Connect vacuum pump gauge (with hose) to MAP sensor as shown in figure.
3. Turn ignition switch ON.
4. While applying negative pressure (vacuum) to MAP sensor, measure "29" terminal voltage. (See page 3-36 and 3-37 for procedure)

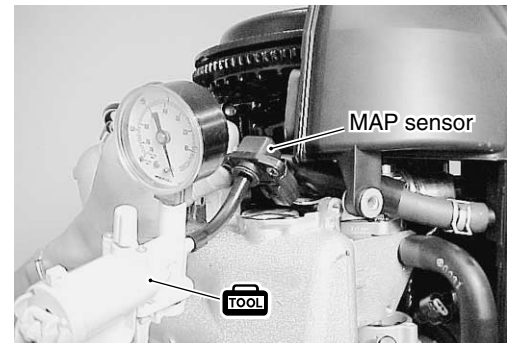
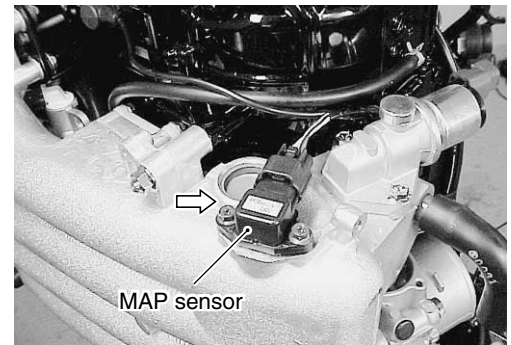



MAP sensor output voltage change :

Negative pressure kPa (kg/cm², mm Hg)	0 (0, 0)	40 (0.4, 300)	80 (0.8, 600)
"29" terminal voltage (V)	4.00	2.42	0.84

(at 1013 hPa barometric pressure)

CTP SWITCH

-  **09930-99320 : Digital tester**
-  **Tester range : $\overline{\text{---}}$ (Continuity)**

1. Disconnect CTP switch wire.
2. Inspect continuity between CTP switch terminal and body ground.

CTP switch function :

Throttle position	Continuity
Fully closed (switch contact in)	Yes
Not fully closed (switch contact out)	No

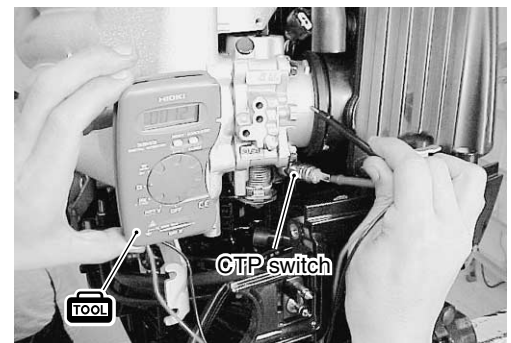

OIL PRESSURE SWITCH

TOOL 09940-44121 : Air pressure gauge
: Air pump

CONT Tester range : (Continuity)

1. Remove bolts and air duct ①.
2. Remove oil pressure switch. (See page 3-54)
3. Connect the gauge and pump as shown in figure.
4. While applying pressure to oil pressure switch, inspect continuity between, switch body and switch terminal bolt as shown in figure.

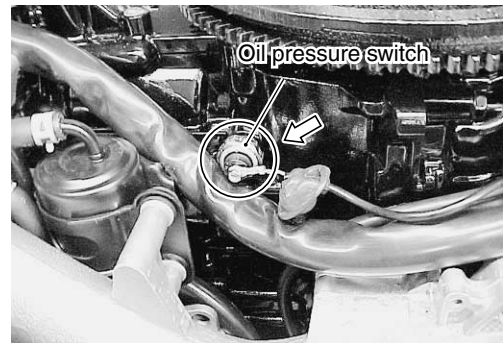
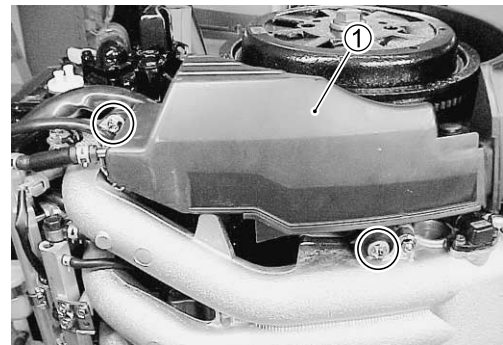

ECM main relay function :

Pressure kPa (kg/cm ²)	Continuity
Less than 70 – 130 (0.7 – 1.3)	Yes
70 – 130 (0.7 – 1.3) or over	No

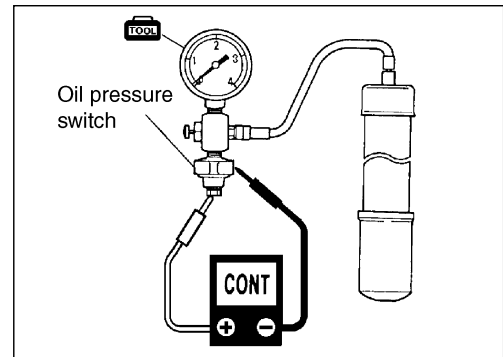

ECM MAIN RELAY

TOOL 09930-99320 : Digital tester

CONT Tester range : (Continuity)

1. Disconnect ECM main relay from wire harness.
2. Inspect continuity between terminal ① and ② each time 12V is applied. Connect positive ⊕ side to terminal ④, and negative ⊖ side to terminal ③.

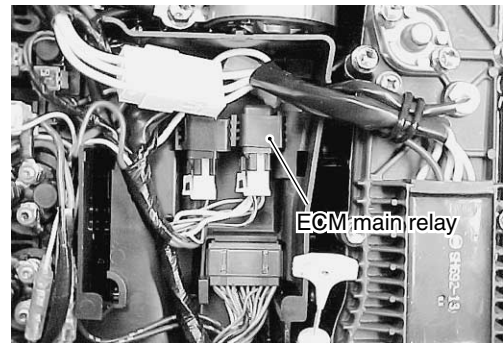

ECM main relay function :

12 V power	Continuity
Applied	Yes
Not applied	No

CAUTION

Be careful not to touch 12V power supply wires to each other or with other terminals.

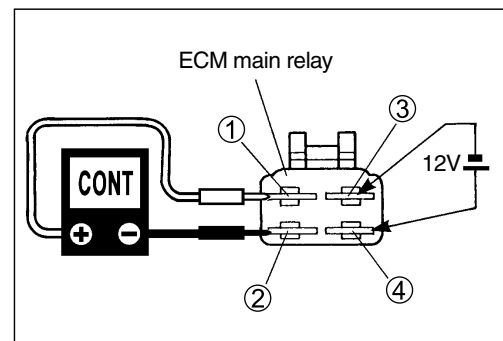

TROUBLESHOOTING

⚠ WARNING

Before starting troubleshooting, read and follow the “PRECAUTION ON SYSTEM INSPECTION” section on page 3-35.

In this section, troubleshooting procedures are based on the assumption that “low pressure fuel system” and “mechanical components (power unit, lower unit, etc.)” are normal.

NOTE:

For troubleshooting of “Starter motor will not run”, see page 4-9.

CHART1 : SELF-DIAGNOSTIC CODE “3-4”

START

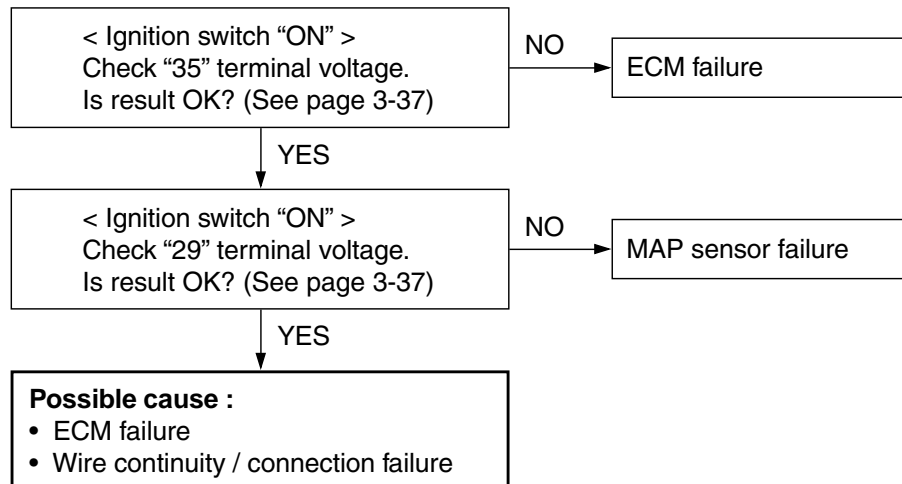
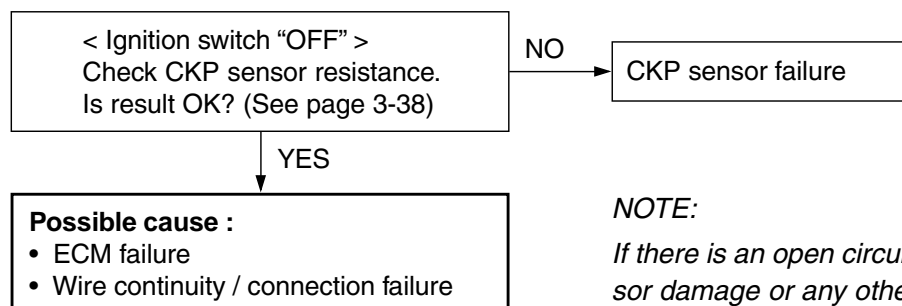

CHART2 : SELF-DIAGNOSTIC CODE “4-2”

START



NOTE:

If there is an open circuit of any of the connector wires, sensor damage or any other malfunction, ignition timing will remain fixed at BTDC 5°.

CHART3 : SELF-DIAGNOSTIC CODE “3-1”

START

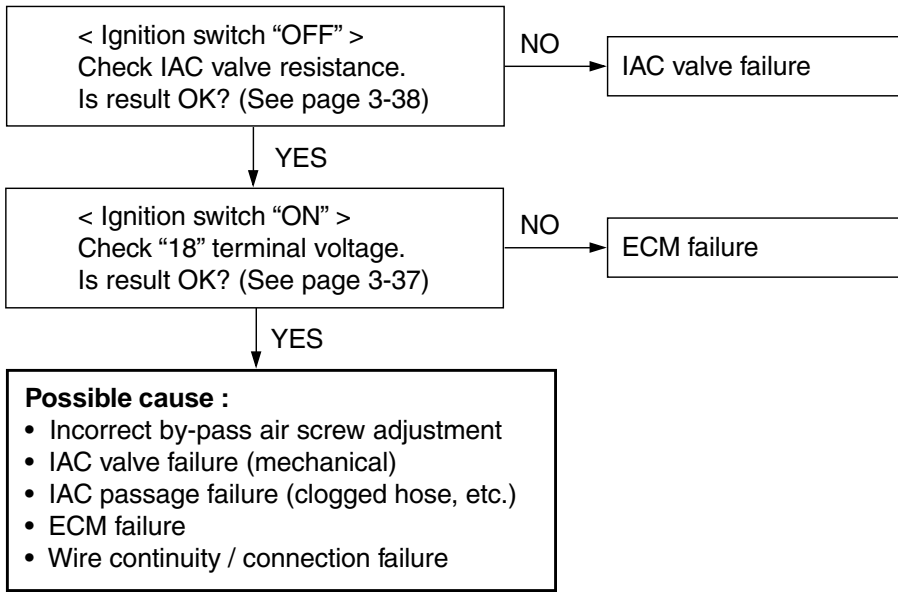
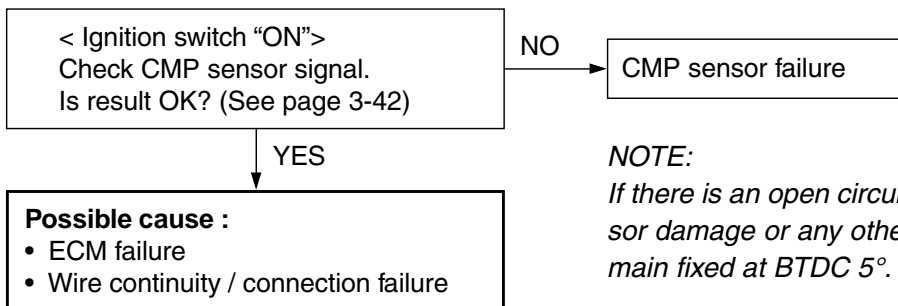

CHART4 : SELF-DIAGNOSTIC CODE “2-4”

START



NOTE:

If there is an open circuit of any of the connector wires, sensor damage or any other malfunction, ignition timing will remain fixed at BTDC 5°.

CHART5 : SELF-DIAGNOSTIC CODE “2-2”

START

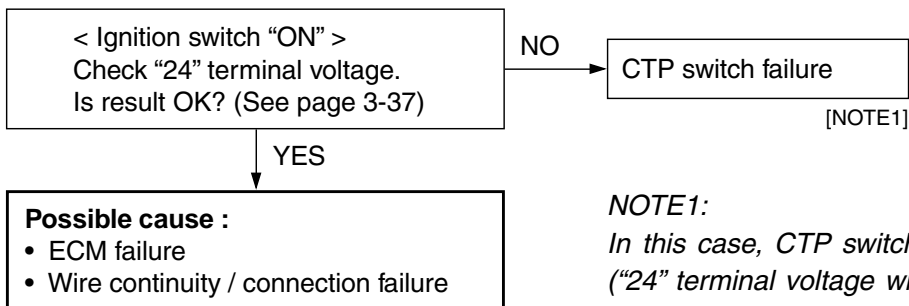

NOTE1:

In this case, CTP switch will be in “always ON” condition. (“24” terminal voltage will be 0V always regardless throttle position.)

CHART6 : SELF-DIAGNOSTIC CODE “1-4”**START****CHART 7 : SELF-DIAGNOSTIC CODE “2-3”****START****CHART8 : SELF-DIAGNOSTIC CODE “3-2”****START**

CHART9 : SELF-DIAGNOSTIC CODE “1-1”

START

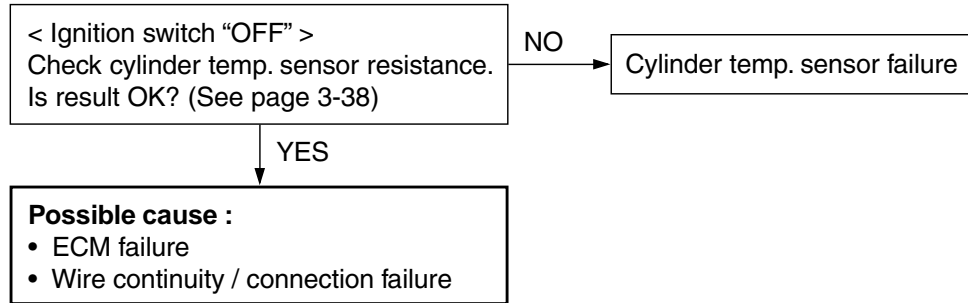
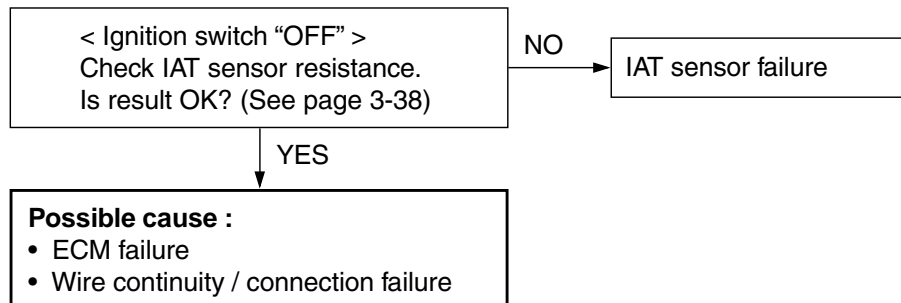
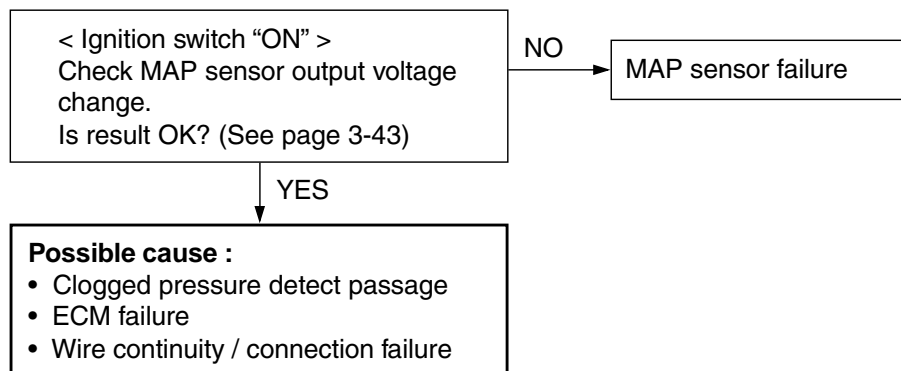
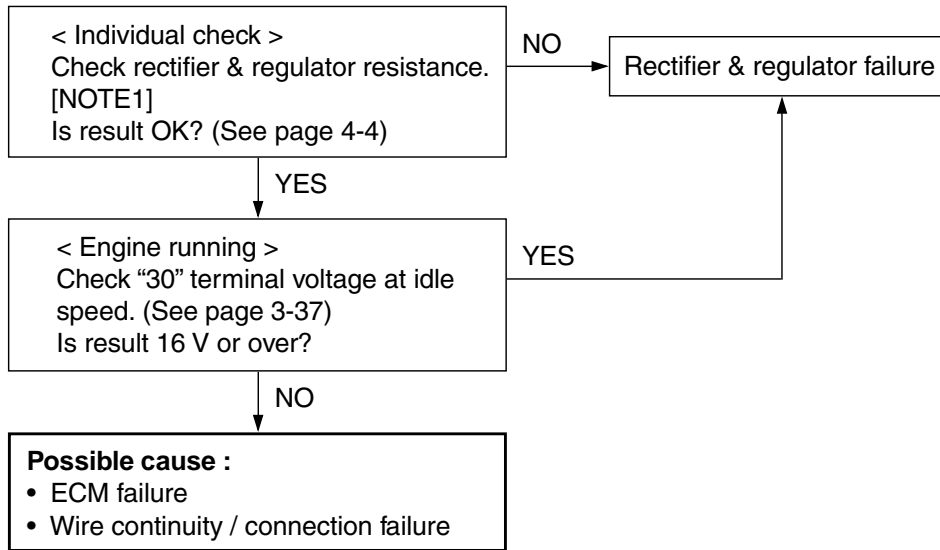

NOTE:

This self-diagnostic code indication may be canceled by turning ignition switch ON because ECM detects battery voltage.

NOTE1:

It is difficult to check rectifier & regulator completely. Before replacing with new one, check if its ground point has good electrical contact.

CHART10 : SELF-DIAGNOSTIC CODE “1-5”

START

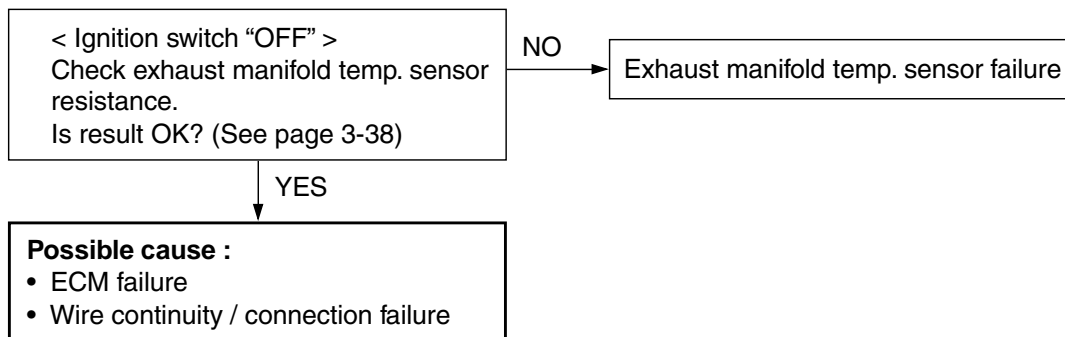

CHART11 : SELF-DIAGNOSTIC CODE “4-3”

START

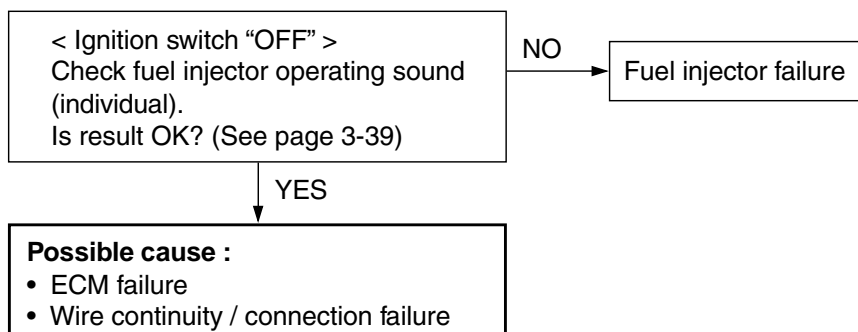

CHART12 : ENGINE CRANKED, BUT NOT START (OR STOPS SHORTLY AFTER STARTING)

Before starting this troubleshooting, make sure that :

- There is no self-diagnostic code indication.
- Emergency stop switch plate is set in place.

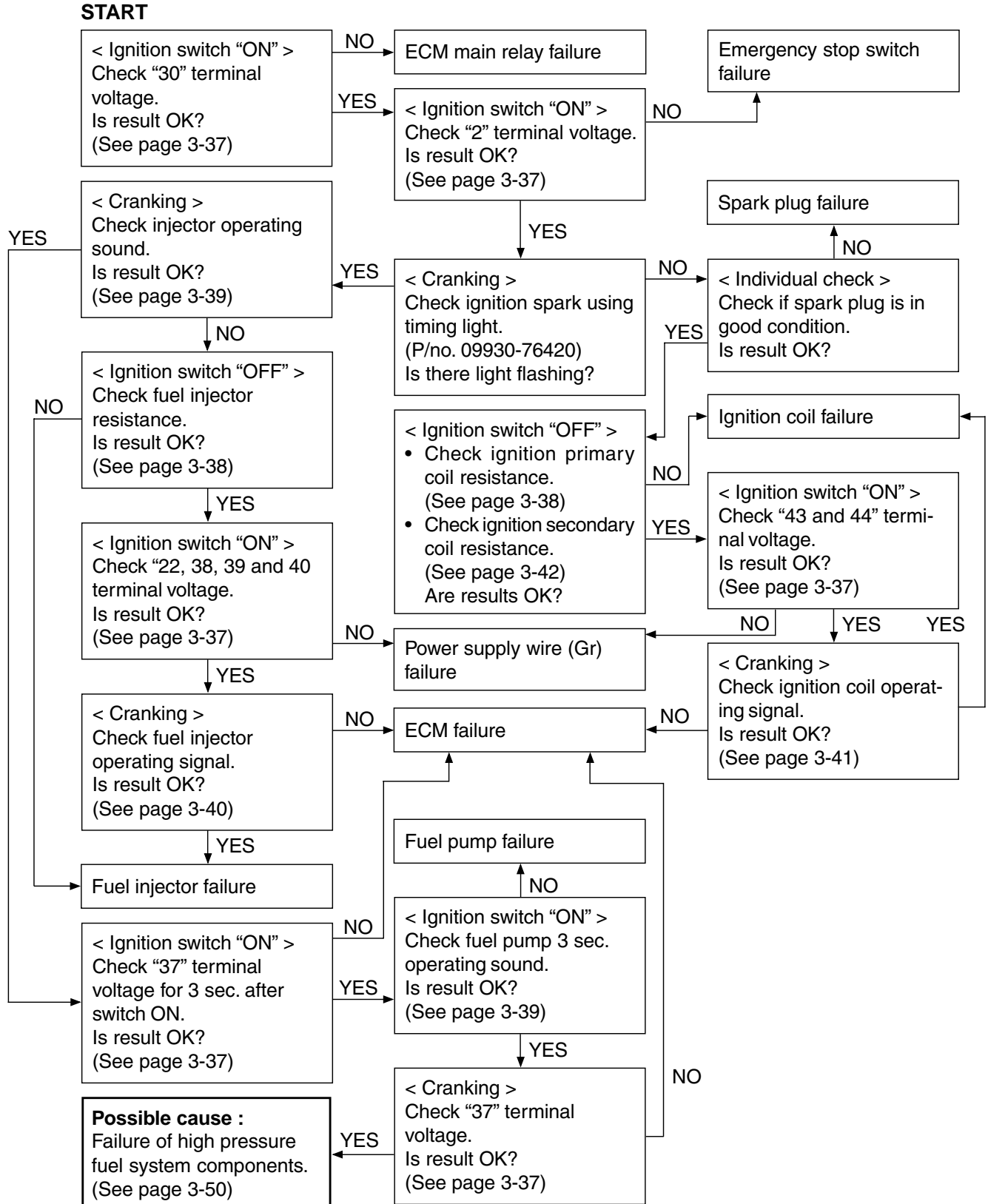
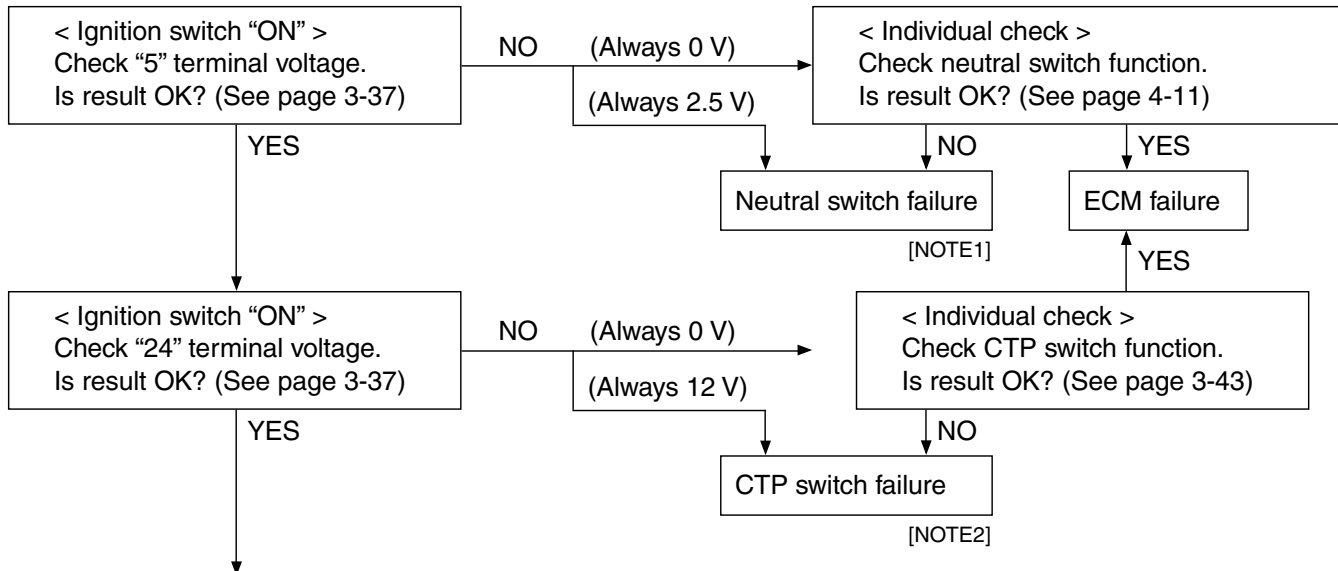

CHART13 : UNSTABLE IDLING / TROLLING (OR ENGINE TENDS TO STALL)

Before starting this troubleshooting, make sure that :

- There is no self-diagnostic code indication.

START**Possible cause :**

- Incorrect by-pass air screw adjustment [NOTE3]
- IAC valve failure [NOTE3]
- IAC passage failure (clogged hose, etc.) [NOTE3]
- Spark plug failure
- Ignition coil failure
- ECM failure
- Wire continuity / connection failure
- Failure of high pressure fuel system components :
 - Fuel injector (clog, stuck valve, etc.)
 - Fuel pressure regulator (incorrect regulated pressure, etc.)
 - Fuel pump (clogged suction filter, leakage in tank, etc.)
 - Fuel filter (clog, etc.)
 - Hose (clog, kink, leakage, etc.)

NOTE1:

If neutral switch has failed (while engine running), engine will tend to stall when shifting into gear.

If neutral switch has failed as "always ON", engine speed is limited to 3000 r/min. by intermittent fuel injection and ignition timing is fixed at BTDC 8°.

If neutral switch has failed as "always OFF", engine can not be cranked.

NOTE2:

If CTP switch has failed, engine will tend to stall when decelerating.

NOTE3:

- The self-diagnostic code "3-1" may not be indicated because IAC valve condition depends on ECM control. (See page 3-29)
- If IAC valve has failed, "Fast-idle function (warm-up mode)" won't operate.

REMOVAL / INSTALLATION FLYWHEEL

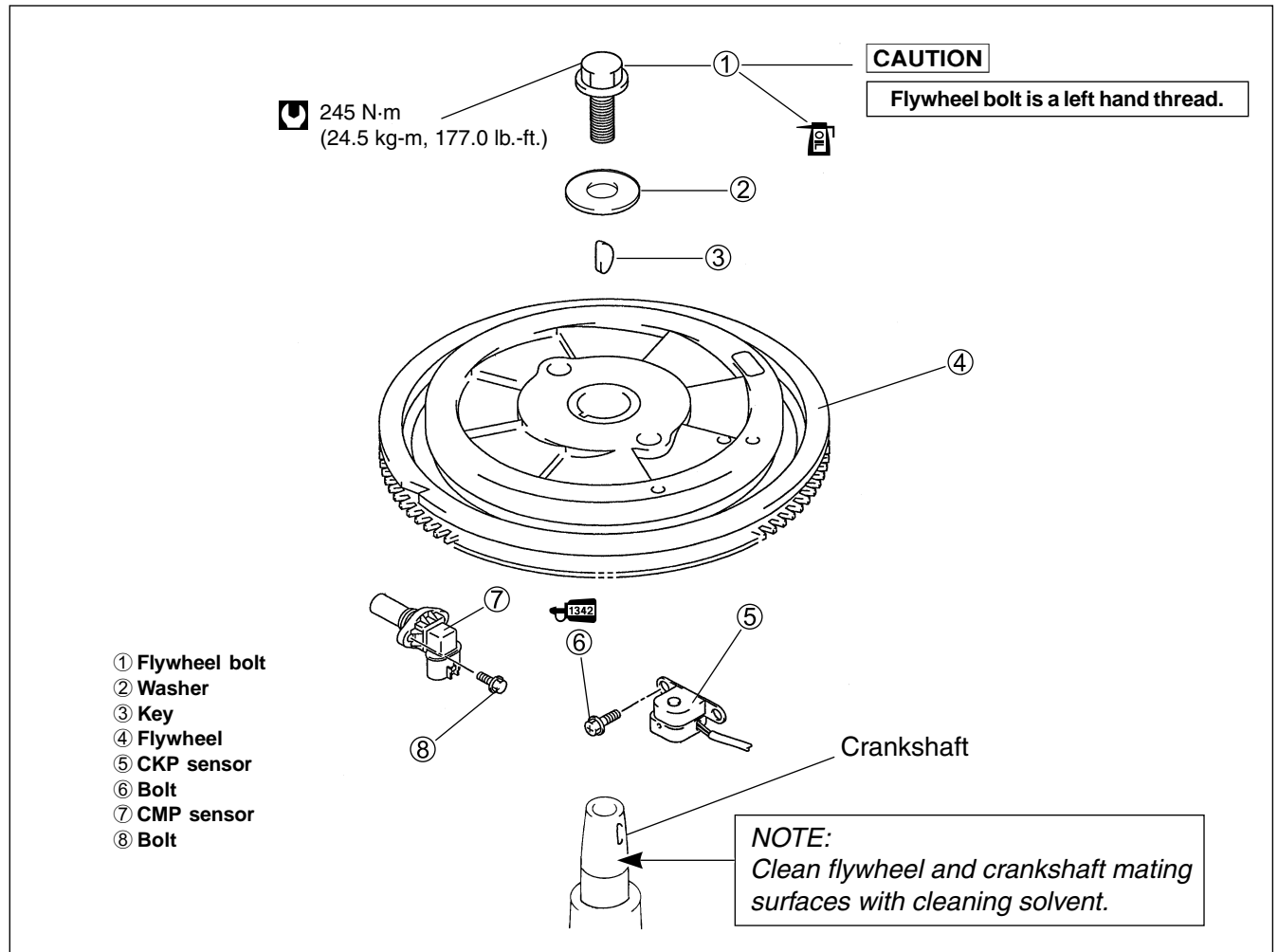

REMOVAL

Prior to removing flywheel :

- Disconnect battery cables from battery.

1. Remove flywheel cover.
2. Loosen flywheel bolt 2 – 3 turns to right direction.

CAUTION

Flywheel bolt is a left hand (LH) thread.

TOOL 09930-48720 : Flywheel holder

NOTE:

Do not remove flywheel bolt at this time.
This bolt prevents damage to crankshaft when using flywheel remover tools.

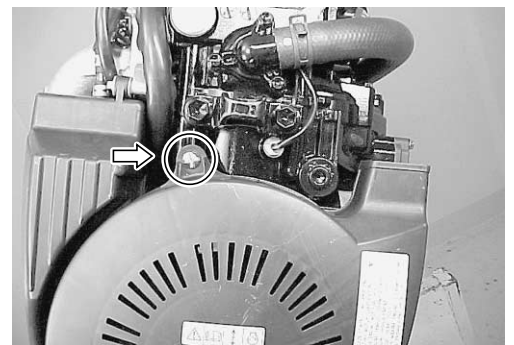

3. Using special tools, loosen flywheel from crankshaft.

-  **09930-39411 : Flywheel remover**
- 09930-39420 : Flywheel remover bolt**

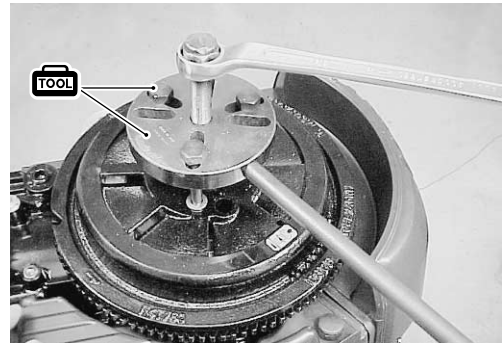

4. Remove flywheel bolt ①, washer ②, flywheel ③ and key ④.

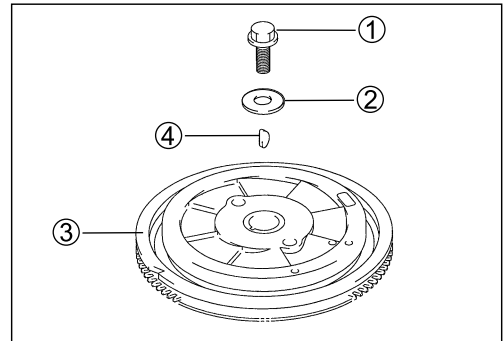

INSTALLATION

Installation is reverse order of removal with special attention to the following steps.

- Clean flywheel and crankshaft mating surfaces with cleaning solvent.
- Apply engine oil lightly to flywheel bolt before installing.
- Tighten flywheel bolt to specified torque.

-  **09930-48720 : Flywheel holder**

-  **Flywheel bolt : 245 N·m (24.5 kg-m, 177.0 lb.-ft.)**

- Measure air gap between CKP sensor and reluctor bars on flywheel magneto. (See page 3-53)

Air gap : 0.75 mm (0.030 in.)

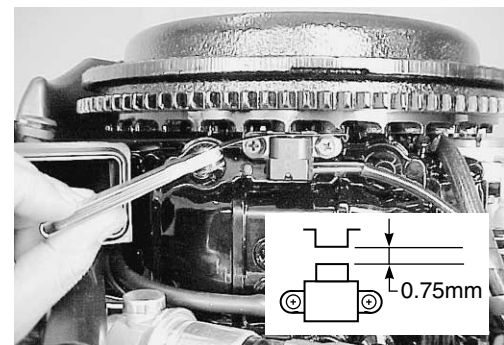
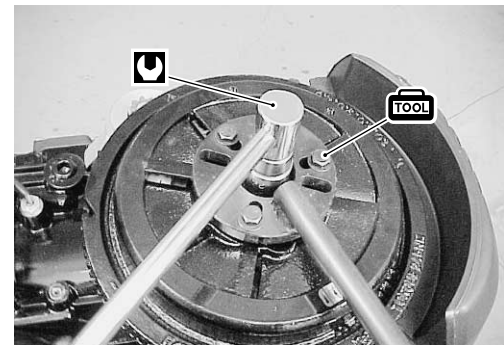

CKP SENSOR

REMOVAL

Prior to removing CKP sensor :

- Disconnect battery cables from battery.

1. Remove flywheel cover.
2. Remove three (3) bolts and air silencer case ①.
Disconnect IAT sensor lead wire connector at IAT sensor.
3. Disconnect CKP sensor lead wire connector in electric parts holder.
4. Remove two (2) bolts and CKP sensor ②.

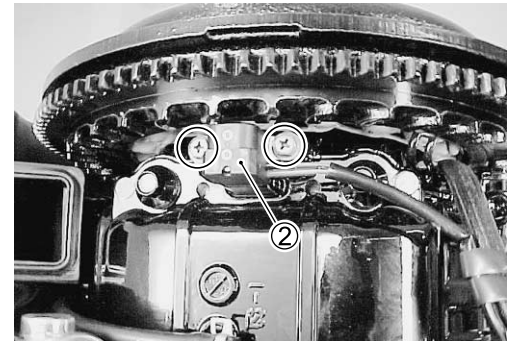
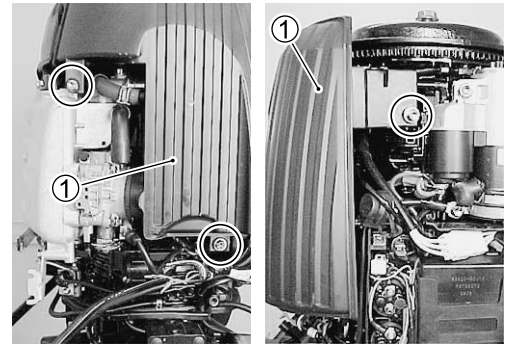

INSTALLATION

Installation is reverse order of removal with special attention to the following steps.

- Apply Thread Lock 1342 to sensor mounting bolts.

 99000-32050 : Thread Lock 1342

- Install CKP sensor with air gap of 0.75 mm between sensor and reluctor bar on flywheel, then tighten sensor mounting screw securely.

Air gap : 0.75 mm (0.030 in.)

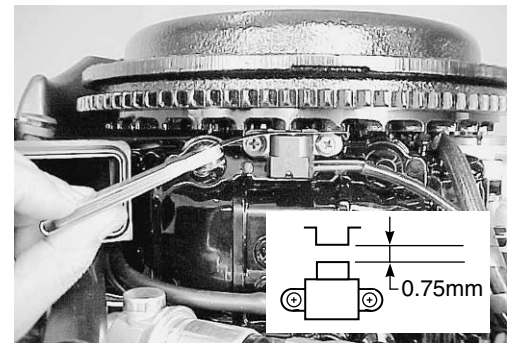
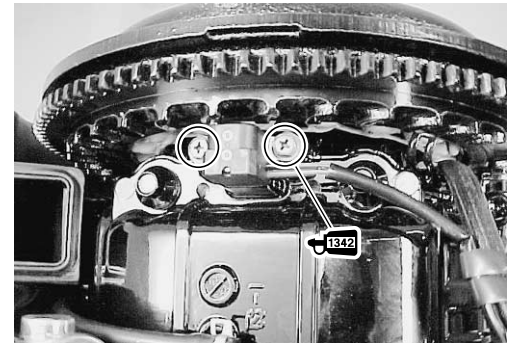

CMP SENSOR

REMOVAL

1. Disconnect CMP sensor lead wire connector at CMP sensor.
2. Remove bolt and CMP sensor.

INSTALLATION

Installation is reverse order of removal.

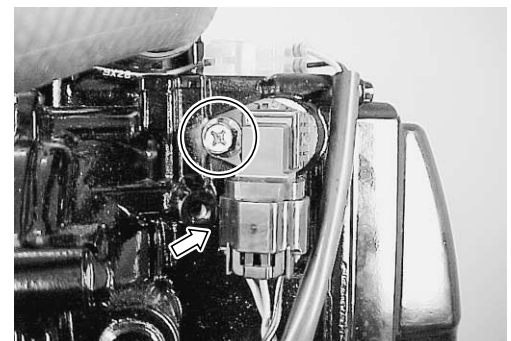

OIL PRESSURE SWITCH

REMOVAL

1. Remove bolts and air duct ①.
2. Loosen bolt and disconnect blue lead wire from switch.
3. Remove oil pressure switch from cylinder block.

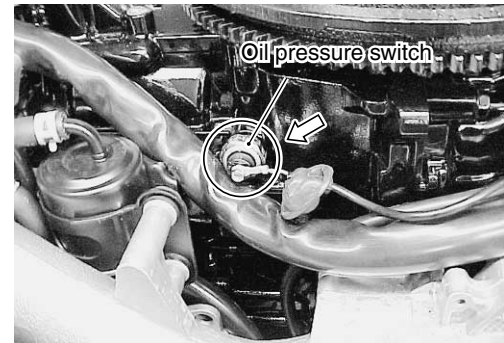
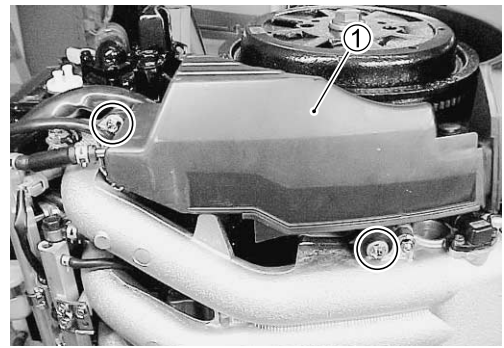

INSTALLATION

Installation is reverse order of removal with special attention to the following steps.

- Before installing oil pressure switch, wrap screw threads with sealing tape then tighten switch to specified torque.

NOTE:

Cut off any excess sealing tape from switch threads before installation.

 **Oil pressure switch : 13 N·m (1.3 kg-m, 9.5 lb.-ft.)**

- Start engine and check oil pressure switch for oil leakage. Reseal switch if oil leakage is found.

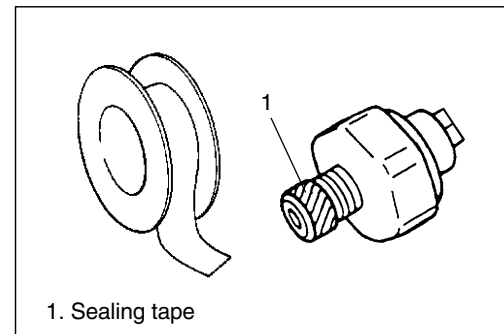

ELECTRICAL

CONTENTS

BATTERY CHARGING SYSTEM	4-2
OUTLINE	4-2
INSPECTION	4-3
REMOVAL / INSTALLATION	4-5
ELECTRIC STARTER SYSTEM	4-7
OUTLINE	4-7
TROUBLESHOOTING	4-9
INSPECTION	4-10
STARTER MOTOR	4-12
REMOVAL / INSTALLATION	4-12
DISASSEMBLY	4-13
INSPECTION & SERVICING	4-16
ASSEMBLY	4-21
PERFORMANCE TEST	4-22
MONITOR-TACHOMETER	4-24
INSPECTION	4-24
ELECTRIC PARTS HOLDER	4-25
REMOVAL / INSTALLATION	4-25

BATTERY CHARGING SYSTEM

OUTLINE

The battery charging system circuit is illustrated below. It is composed of the BATTERY CHARGE COIL, RECTIFIER & REGULATOR and BATTERY. The three phase AC current generated from battery charge coil is converted by the rectifier & regulator into regulated DC current which is used to charge the battery.

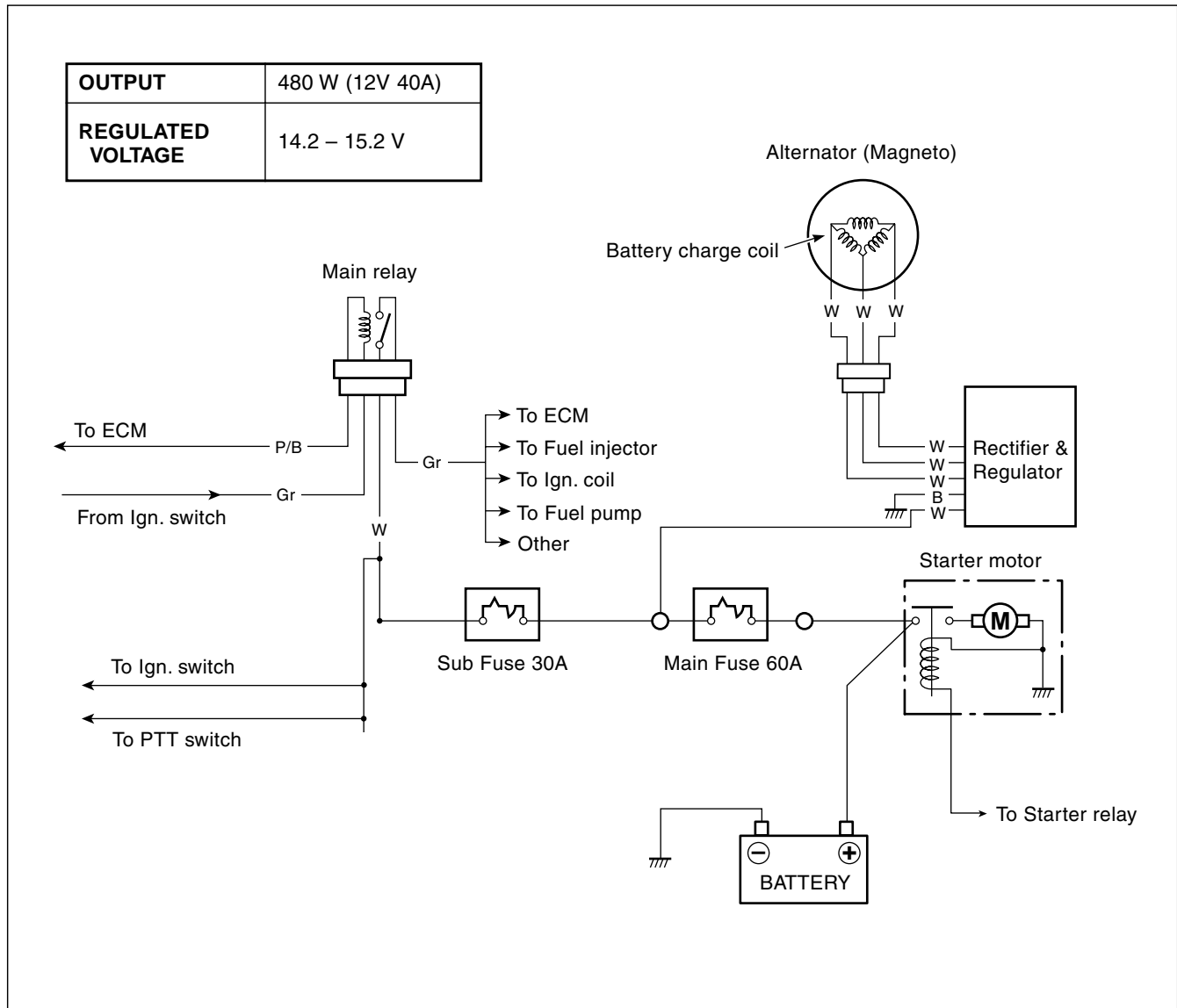

INSPECTION

BATTERY CHARGE COIL

Measure battery charge coil resistance.

 **09930-99320 : Digital tester**

 **Tester range : Ω (Resistance)**

1. Disconnect battery charge coil leads from rectifier & regulator.
2. Measure resistance between leads in the combinations shown.

Battery charge coil resistance :

Terminal for tester probe connection	Resistance
White 1 to White 2	0.16 – 0.24 Ω
White 2 to White 3	
White 3 to White 1	

If out of specification, replace battery charge coil.

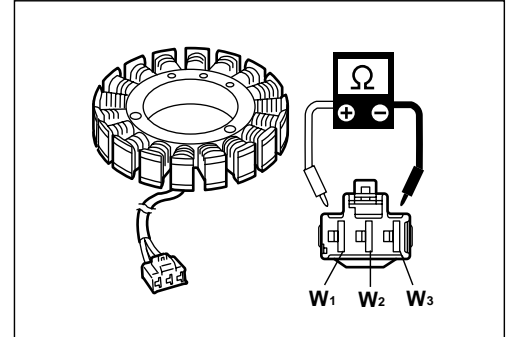

FUSE CASE / FUSE

 **09930-99320 : Digital tester**

 **Tester range : \rightarrow (Continuity)**

Fuse

1. Remove fuse from fuse case (or fuse terminal).
2. Inspect continuity between both terminals of fuse.
If no continuity is exists, replace fuse.

Main fuse : 60A

Sub fuse : 30A

Main fuse terminal

Inspect continuity between terminal (A) and (B).

If no continuity is exists, replace fuse terminal and/or fuse.

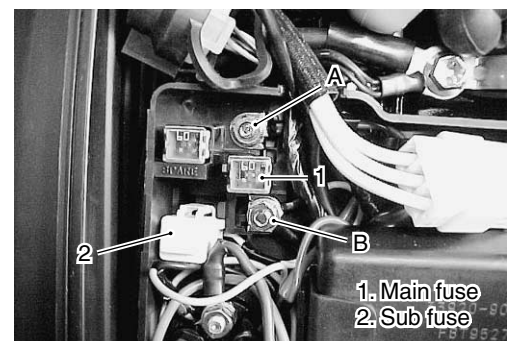
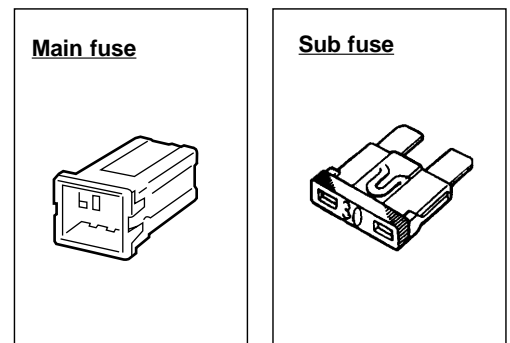

Sub fuse case

1. Disconnect white lead wire of fuse case from terminal (B).
2. Inspect continuity between White lead wire with plate terminal and White lead wire of main harness 8P connector.
If no continuity is exists, replace main harness and/or fuse.

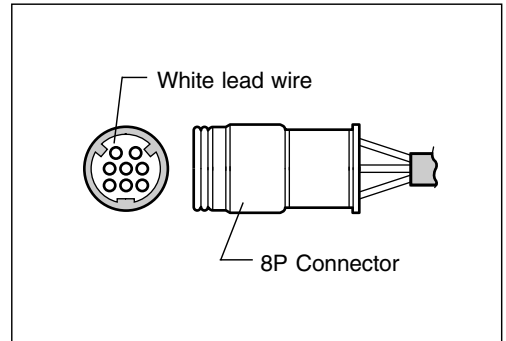
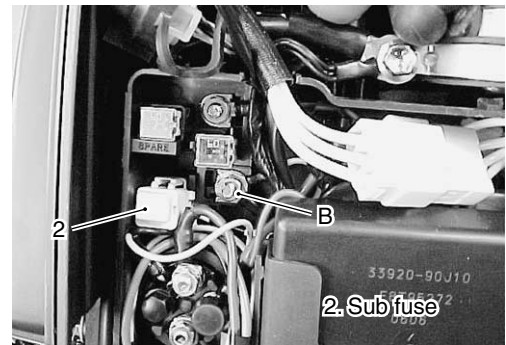

RECTIFIER & REGULATOR

09900-25002 : Pocket tester

Tester range : x1 kΩ (Resistance)

1. Disconnect all lead wires of rectifier & regulator.
2. Measure resistance between leads in combinations shown.

NOTE:

The values given below are for a SUZUKI pocket tester.
As thyristors, diodes, etc. are used inside this rectifier & regulator, the resistance values will differ when an ohmmeter other than SUZUKI pocket tester is used.

Rectifier & regulator resistance :

Unit : Approx. kΩ

		Tester probe ⊕ (Red)				
		Black	White	White 1	White 2	White 3
Tester probe ⊖ (Black)	Black		1~20	0.5~100	0.5~100	0.5~100
	White	3~60		4~80	4~80	4~80
	White 1	4~80	0.5~10		5~100	5~100
	White 2	4~80	0.5~10	5~100		5~100
	White 3	4~80	0.5~10	5~100	5~100	

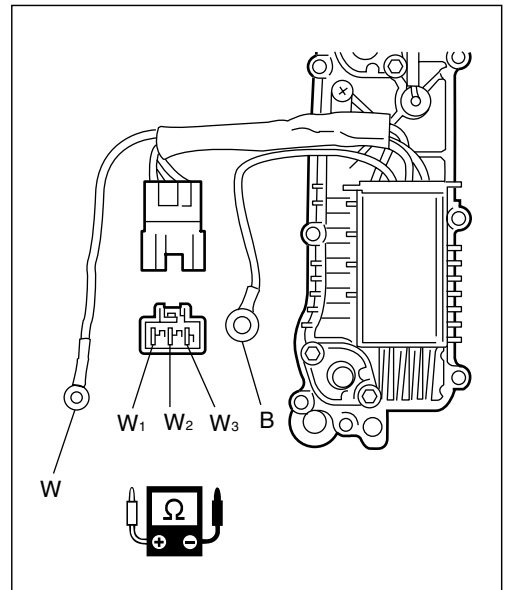

If measurement exceeds specification, replace rectifier & regulator.

REMOVAL / INSTALLATION

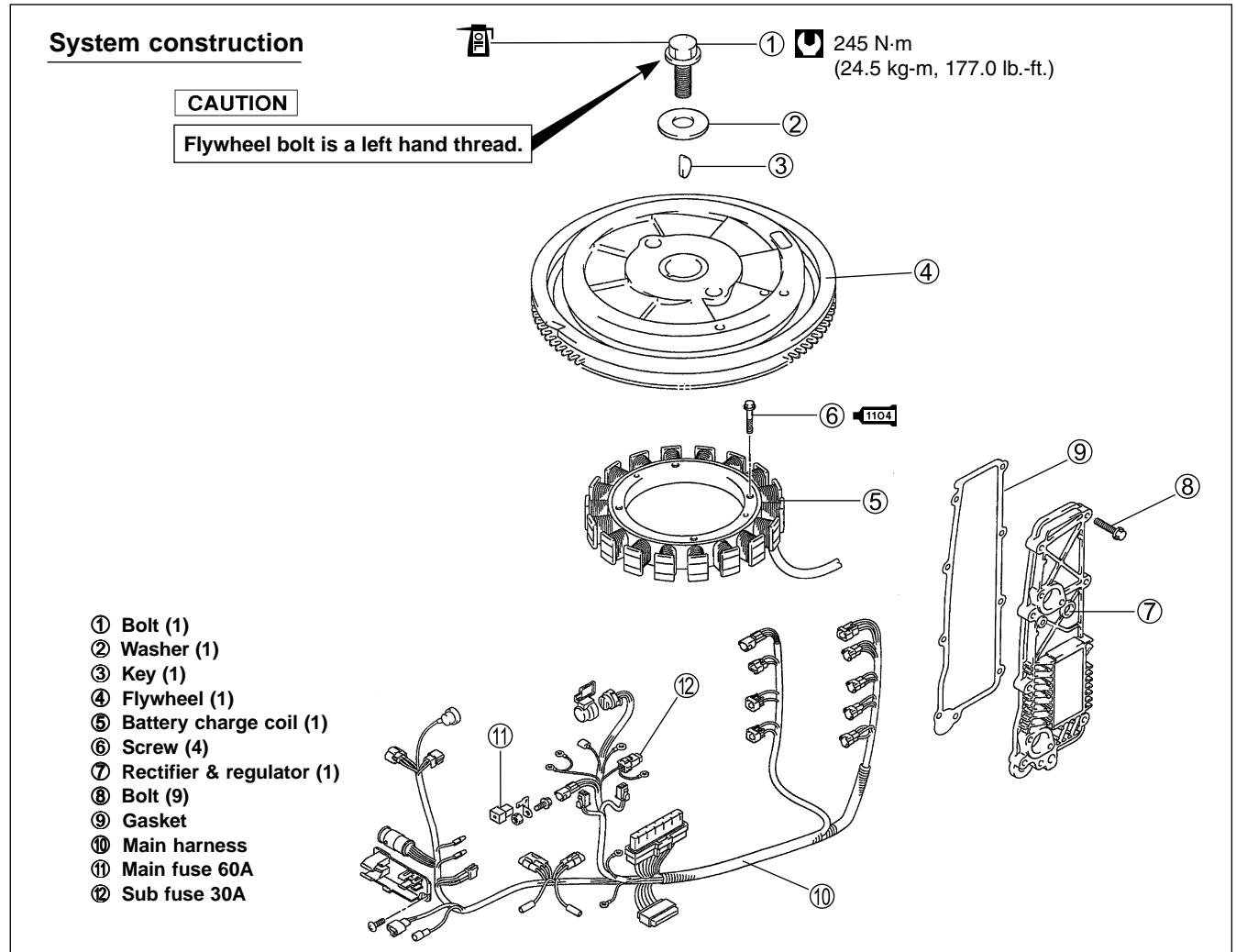

REMOVAL

Prior to removing electrical parts :

- Disconnect battery cables from battery.

Battery charge coil

1. Remove flywheel. (See page 3-51)
2. Remove four screws securing battery charge coil.
3. Disconnect battery charge coil lead wire connector from rectifier & regulator.
4. Remove battery charge coil.

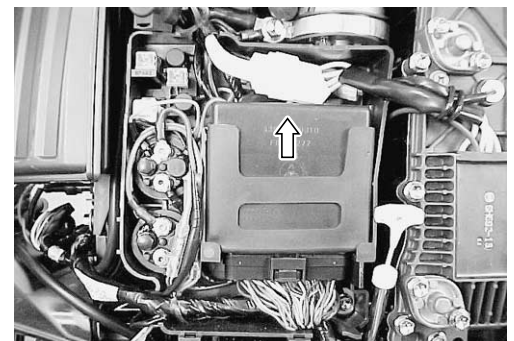
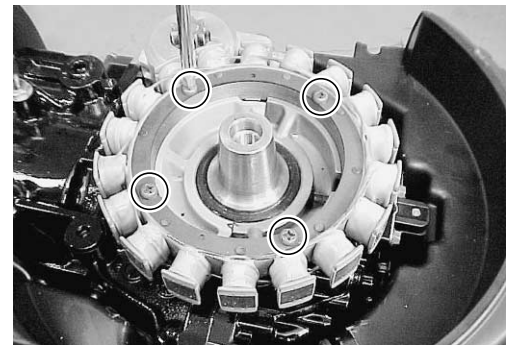

Rectifier & regulator

1. Remove electric parts holder. (See page 4-25)
2. Remove bolt securing ground lead wire of Rectifier & regulator.
3. Remove bolts securing exhaust cover (Rectifier & regulator).
4. Remove exhaust cover with rectifier & regulator.

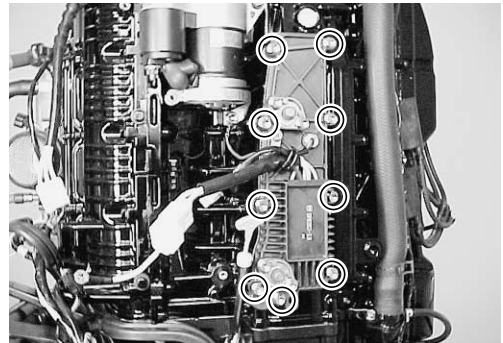
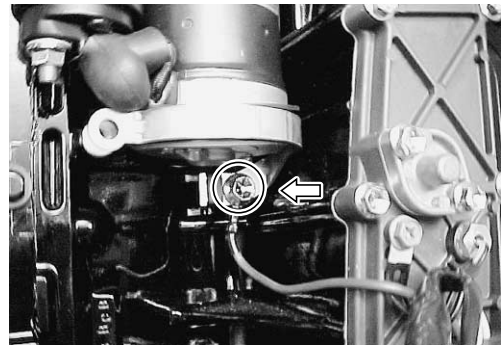

INSTALLATION

Installation is reverse order of removal with special attention to the following step.

Battery charge coil

Apply Suzuki Bond No. 1104 to coil securing screws.

 99000-32050 : Suzuki Bond No. 1104

Wire routing

Check wire routing. (See page 10-2 to 10-7)

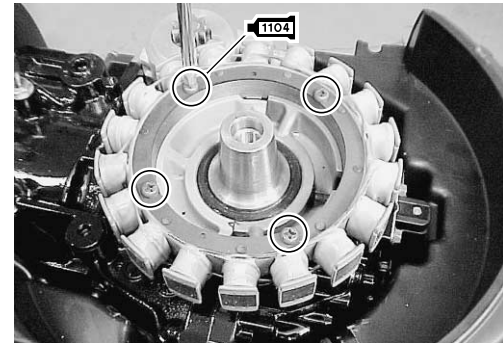

ELECTRIC STARTER SYSTEM

OUTLINE

The starting circuit consists of the battery, starting motor, ignition switch, neutral switch and related electrical wiring.

These components are connected electrically as shown in figure below.

STARTING SYSTEM CIRCUIT

In the circuit shown in figure below, the magnetic switch coils are magnetized when the ignition switch is closed (turn to "START").

The resulting plunger and pinion shift lever movement causes the pinion to engage the engine flywheel gear, the magnetic switch main contacts to close, and engine cranking to take place.

When the engine starts, the pinion over-running clutch protects the armature from excessive speed until the switch is opened, at which time the torsion spring causes the pinion to disengage.

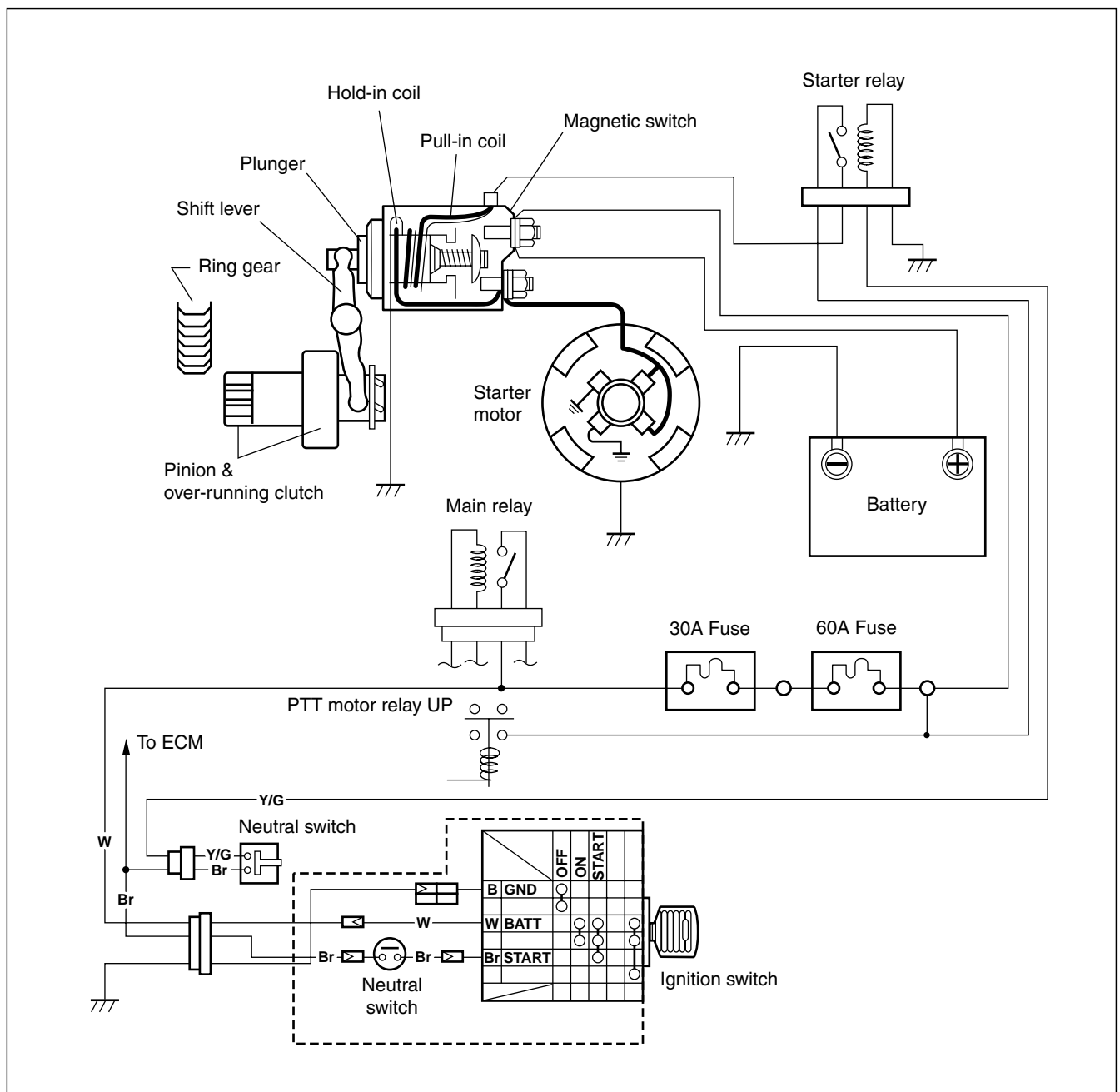

STARTER ENGAGEMENT MECHANISM

A solenoid (electromagnetic force) type starter switch, utilizing a torsion spring and shift lever, engages the pinion gear to the flywheel.

When the ignition key is turned to "START", current flows through the switch winding creating an electromagnet pulling the plunger in.

The shift lever, attached to the plunger, then pushes the pinion up into engagement with the flywheel. Plunger and shift lever movement also compresses the torsion spring, which applies pressure against the shift lever and pinion gear to maintain positive engagement.

Final plunger movement closes the starter switch contacts, which allows current to flow through the starter motor windings, rotating the starter motor armature, pinion gear and flywheel.

When the ignition key is released from start, current flow to the switch is shut off and electromagnetic force ceases. The torsion spring then pulls the plunger out, disengaging the pinion gear from the flywheel through the shift lever.

Movement of the plunger also opens the switch contacts, stopping current flow to the starter motor windings, shutting off the starter motor.

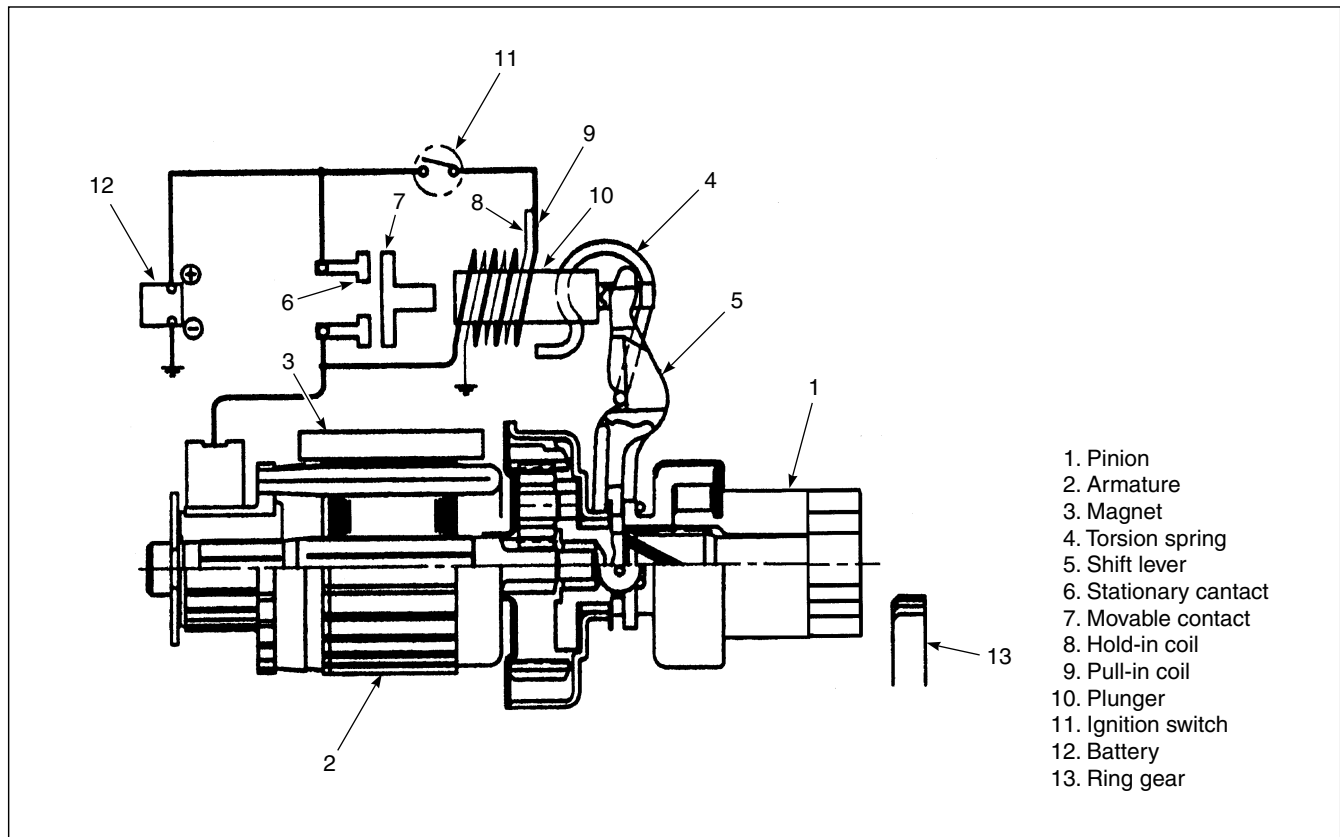

- 1. Pinion
- 2. Armature
- 3. Magnet
- 4. Torsion spring
- 5. Shift lever
- 6. Stationary contact
- 7. Movable contact
- 8. Hold-in coil
- 9. Pull-in coil
- 10. Plunger
- 11. Ignition switch
- 12. Battery
- 13. Ring gear

TROUBLESHOOTING

NOTE:

Before troubleshooting the electric starter system, make sure of the following :

- Battery is fully charged.
- All cables / wires are securely connected.
- Shift is in "NEUTRAL" position.

CAUTION

If any abnormality is found, immediately disconnect battery cables from battery.

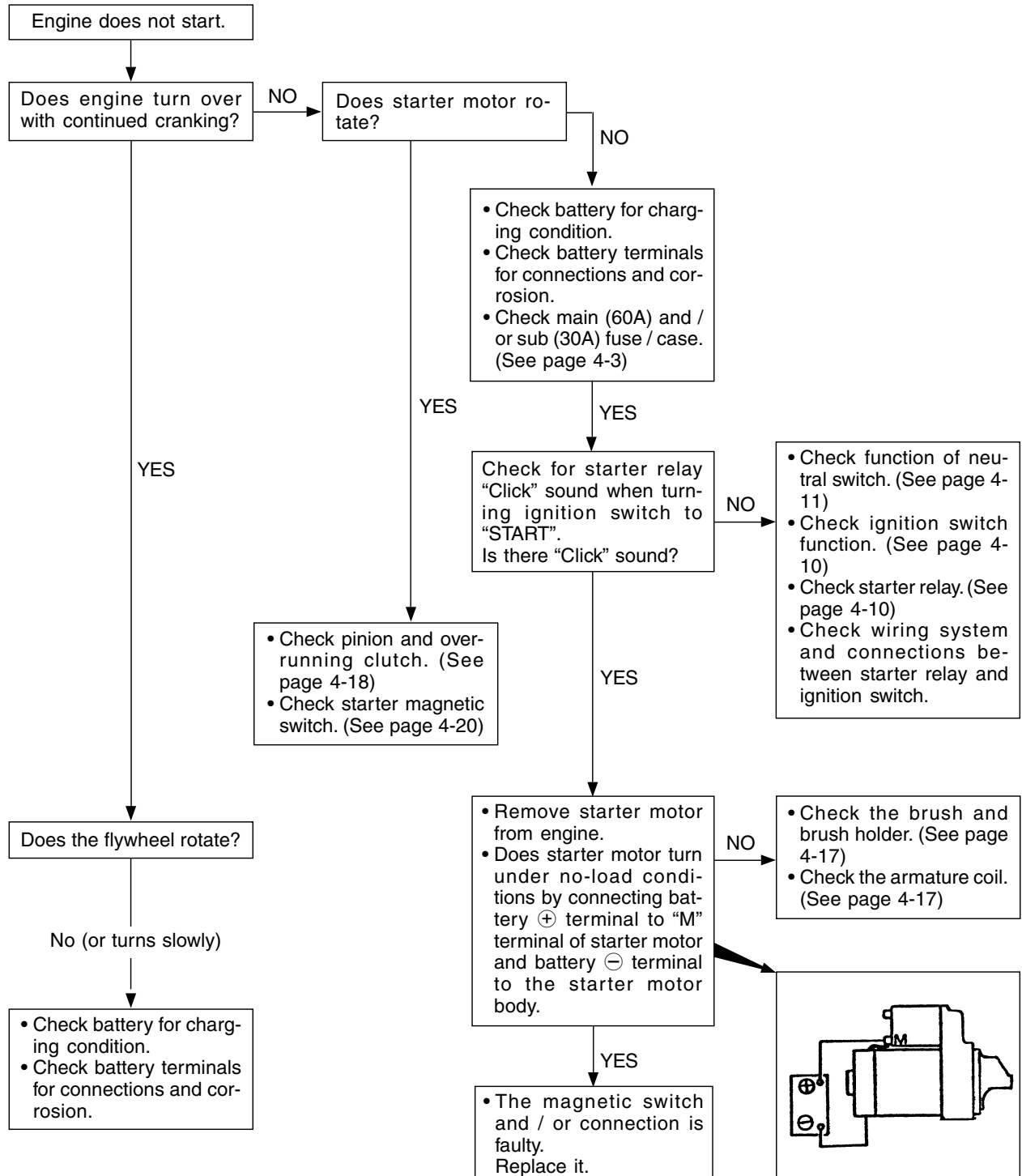

INSPECTION

IGNITION SWITCH

TOOL 09930-99320 : Digital tester

CONT Tester range : (Continuity)

1. Disconnect ignition switch from remo-con box wiring harness.
2. Inspect continuity between wiring leads at key positions shown in chart.

Key Position	Switch Lead Wires					
	Black	Green	White	Gray	Brown	Orange
① OFF	○—○					
② ON			○—○			
③ START			○—○—○			
④ FREE						
⑤ PUSH			○—○—○—○			



If out of specification, replace ignition switch. : Continuity

STARTER MOTOR RELAY

TOOL 09930-99320 : Digital tester

CONT Tester range : (Continuity)

1. Disconnect starter motor relay from wire.
2. Inspect continuity between terminal ① and ② each time 12V is applied. Connect positive \oplus side to terminal ④, and negative \ominus side to terminal ③.

Starter motor relay function :

12V power	Continuity
Applied	Yes
Not applied	No

CAUTION

Be careful not to touch 12V power supply wires to each other or with other terminals.

3. Measure resistance between relay terminals ③ and ④.

RES Tester range : Ω (Resistance)

Starter motor relay solenoid coil resistance : 80–120 Ω

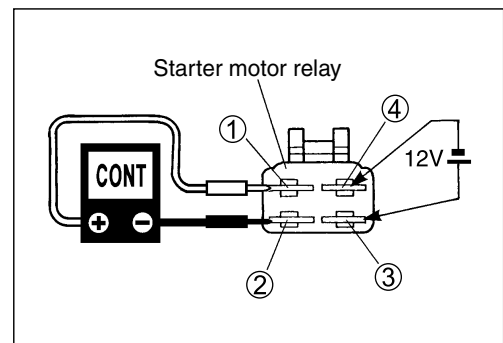
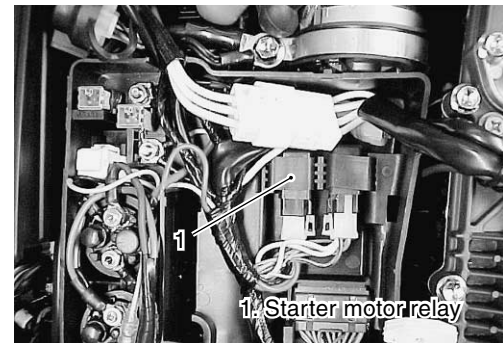
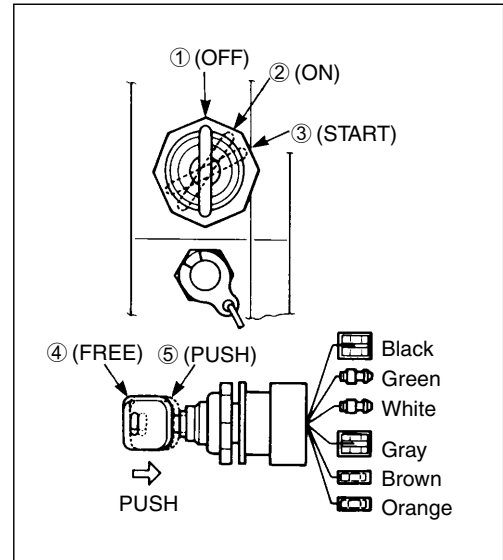

If out of specification, replace starter motor relay.



NEUTRAL SWITCH

Inspect continuity of neutral switch.

 **09930-99320 : Digital tester**

 **Tester range :  (Continuity)**

Neutral switch in remo-con box

1. Disconnect neutral switch lead wires in remo-con box.
2. Inspect continuity between switch Brown lead wires while operating remo-con handle.

Shift position	Continuity
Neutral	Yes
Forward	No
Reverse	No

If out of specification, replace neutral switch.

Neutral switch on cylinder block

1. Disconnect neutral switch lead wire connector.
2. Inspect continuity between Yellow/Green and Brown lead wires while operating remo-con handle.

Shift position	Continuity
Neutral	Yes
Forward	No
Reverse	No

If out of specification :

- 1st Check switch position adjustment, readjust if necessary.
- 2nd Replace neutral switch.

NOTE:

After installing neutral switch, check for proper correct function by operating remo-con handle.

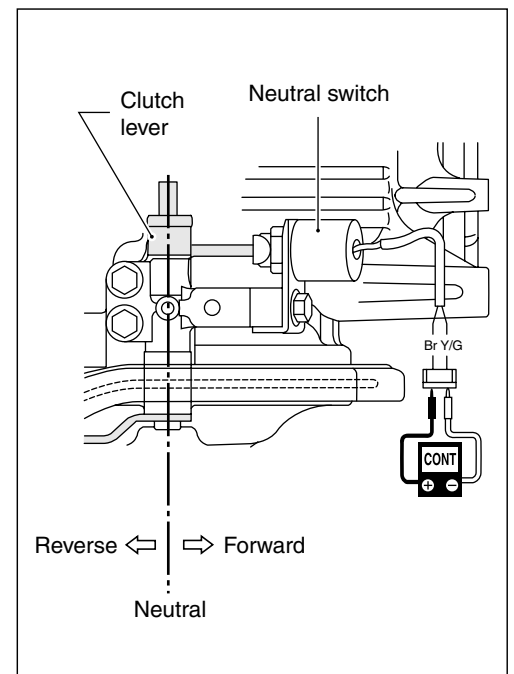
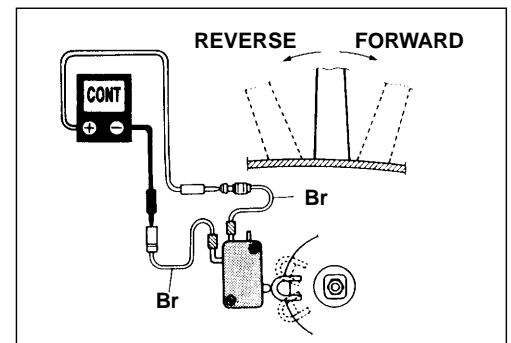

STARTER MOTOR

REMOVAL

Prior to removing starter motor :

- Disconnect battery cables from battery.

1. Remove bolt ① and flywheel cover ②.
2. Remove bolt ③ and negative \ominus battery cable ④.
3. Remove nut ⑤ and positive \oplus battery cable ⑥ from magnetic switch of starter motor.
4. Disconnect Red lead wire ⑦ from terminal "S" of starter magnetic switch.
5. Remove two bolts ⑧ securing starter motor. Remove starter motor ⑨ and dowel pins ⑩.

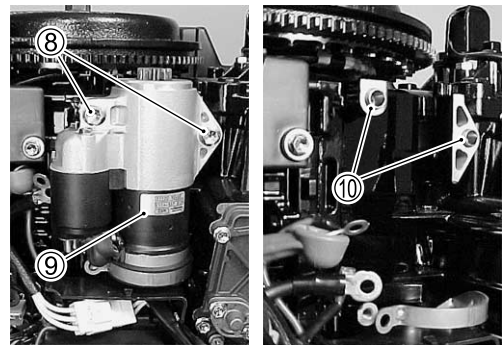
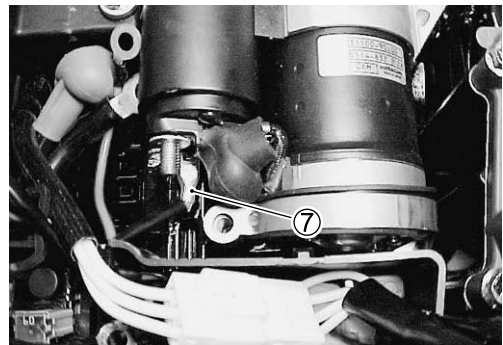
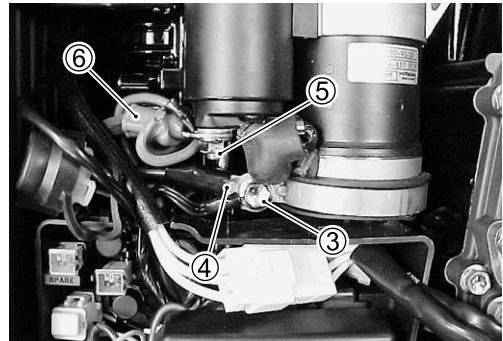
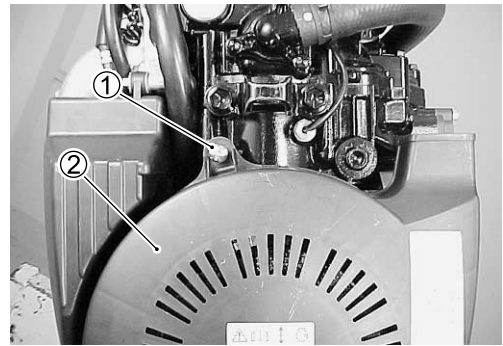

INSTALLATION

Installation is reverse order of removal with special attention to the following steps.

- Apply engine oil lightly to motor mounting bolts before installing.
- Install starter motor and tighten mounting bolts securely.

Starter motor mounting bolt :

8 mm 23 N·m (2.3 kg·m, 16.5 lb.-ft.)

10 mm 50 N·m (5.0 kg·m, 36.0 lb.-ft.)

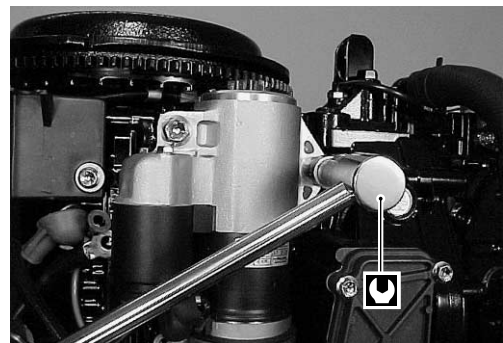

DISASSEMBLY

For overhauling of starting motor, it is recommended that component parts should be cleaned thoroughly.

However, yoke assembly, armature coil, over-running clutch assembly, magnetic switch assembly, rubber or plastic parts should not be washed in degreasing tank or with grease dissolving solvent. Those parts should be cleaned with compressed air and wiping with cloth.

NOTE:

Before disassembling starting motor, be sure to put match marks at three locations (A, B and C) as shown in right figure so that any possible component alignment mistakes can be avoided.

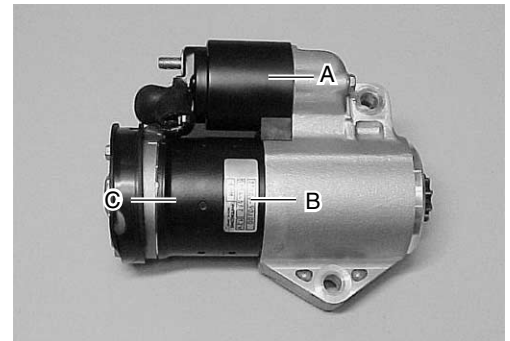

1. Remove nut ① from magnetic switch, then disconnect connecting wire ②.
2. Remove two bolts ③ securing magnetic switch.

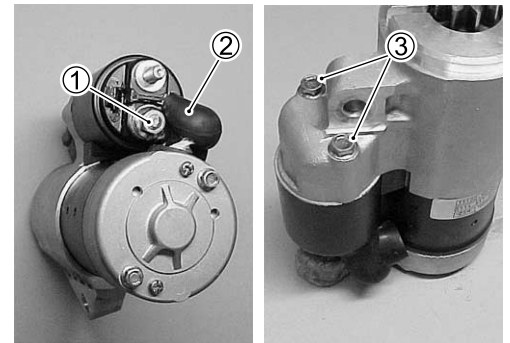

3. Remove magnetic switch ④ and rubber packing ⑤.

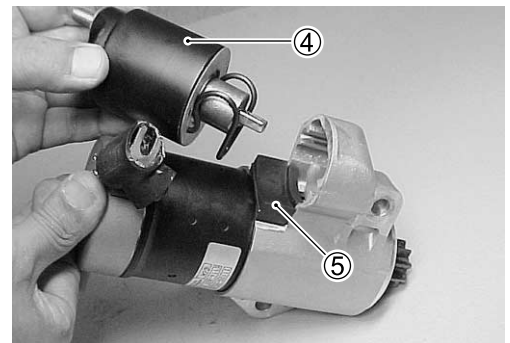

4. Remove screws ⑥, long through bolts ⑦ and rear cover ⑧.

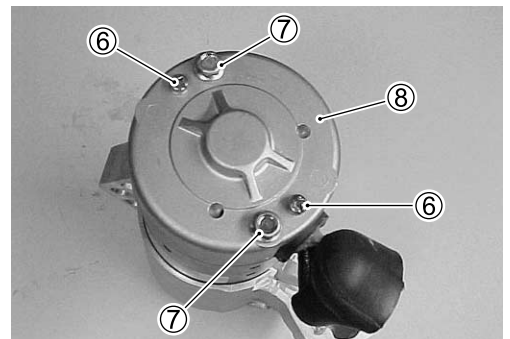

4-14 ELECTRICAL

5. Remove thrust washer ⑨ with screwdriver.

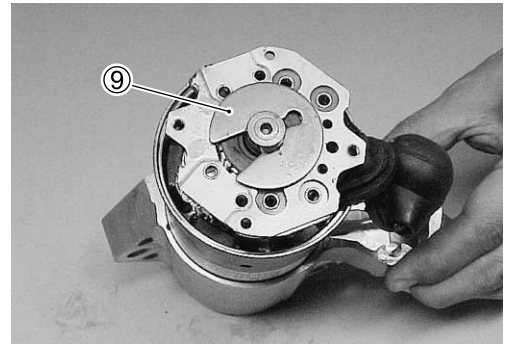

6. Pull brush spring ⑩ up so that brush is separated from surface of commutator, then remove brush holder ⑪.

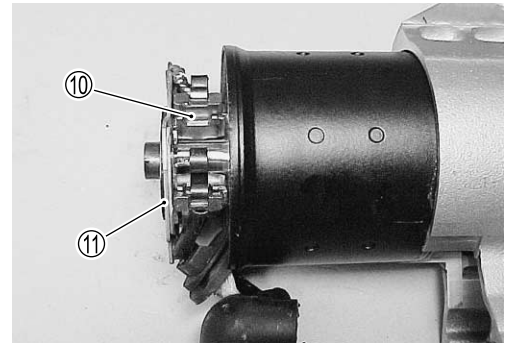

7. Remove yoke ⑫ and armature ⑬.

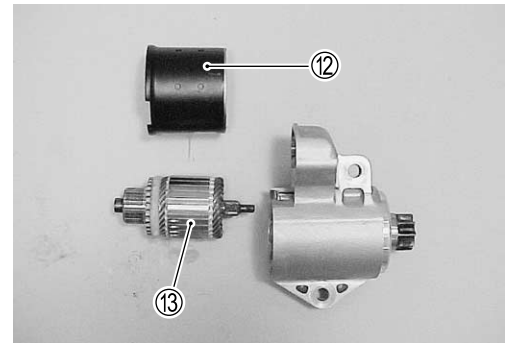

8. Remove center cover plate ⑭.

9. Remove planetary gears ⑮ and internal gear ⑯.

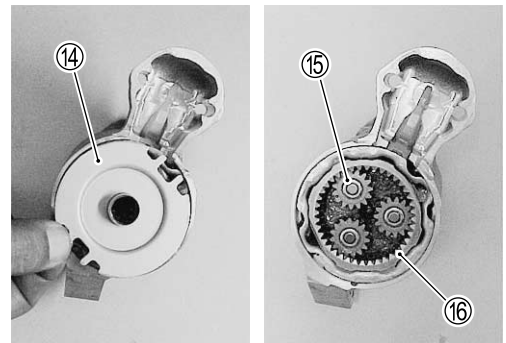

10. Remove center bracket ⑰ (with shift lever ⑲, pinion ⑳ and pinion shaft ㉑) from front housing ⑱.

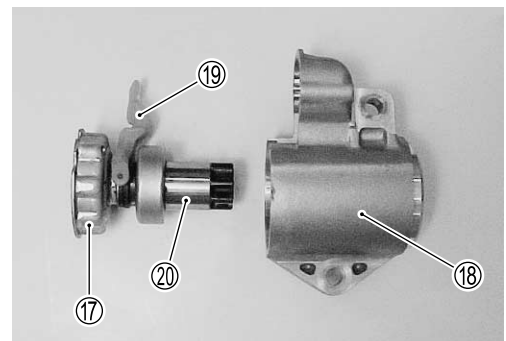

11. Remove shift lever ⑱ and pinion ⑳.

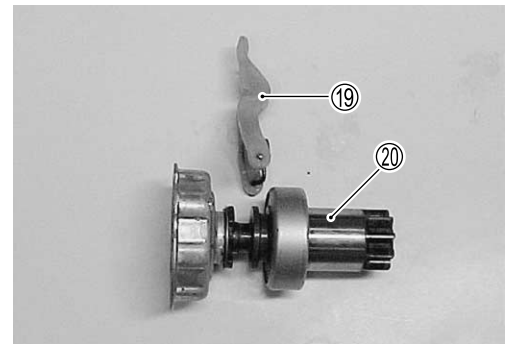

12. Remove E-ring ㉒ and washer ㉓.

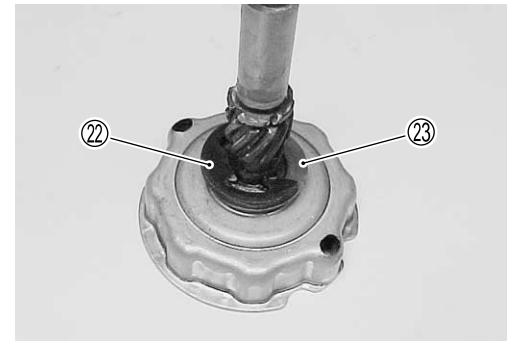

13. Remove pinion shaft ㉑, washer ㉓ and rubber ring ㉔ from center bracket.

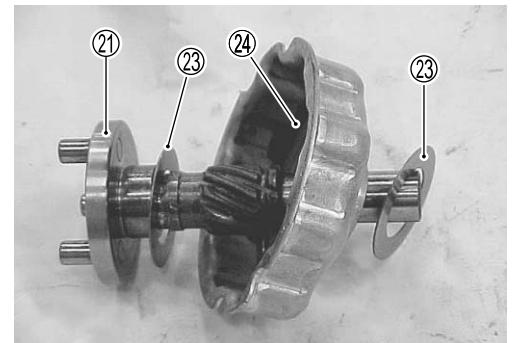

INSPECTION & SERVICING

Armature and Commutator

1. Inspect commutator surface for gum or dirt.
Clean with #500 grit emery paper $\text{\textcircled{A}}$ if necessary.

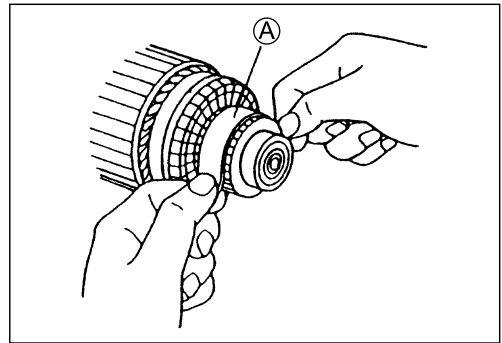

2. Measure commutator outside diameter.

TOOL 09900-20101 : Vernier calipers

Commutator outside diameter:
Standard : 29.0 mm (1.14 in.)
Service limit : 28.0 mm (1.10 in.)

If measurement exceeds service limit, replace armature.

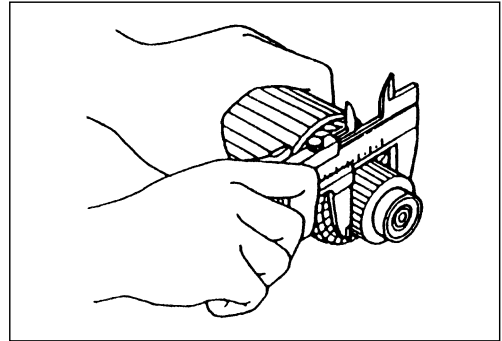

3. Measure commutator undercut (depth) between mica (insulator) and segments.

Commutator undercut $\text{\textcircled{1}}$ (depth):
Standard : 0.5 – 0.8 mm (0.02 – 0.03 in.)
Service limit : 0.2 mm (0.01 in.)

If measurement exceeds service limit, cut mica to specified depth.

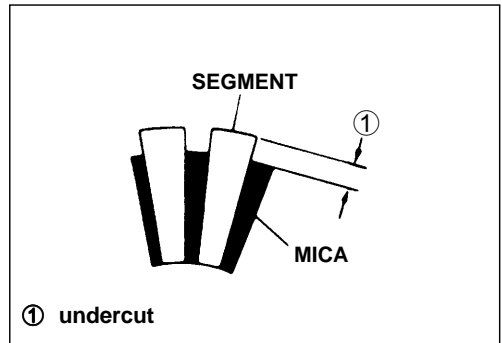

NOTE:

Remove all particles of mica and metal using compressed air.



⚠ WARNING

Wear safety glasses when using compressed air.

- Inspect continuity between commutator and armature core / shaft.

If continuity exists, replace armature.

 **09930-99320 : Digital tester**

 **Tester range :  (Continuity)**

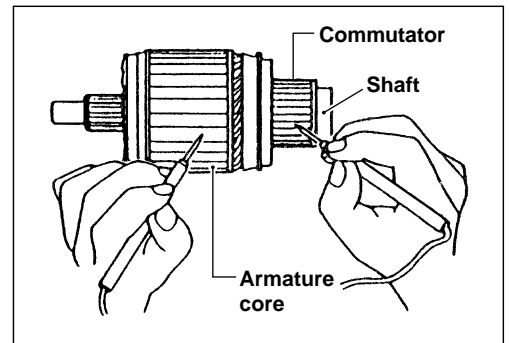

- Inspect continuity between adjacent commutator segments.

If no continuity exists, replace armature.

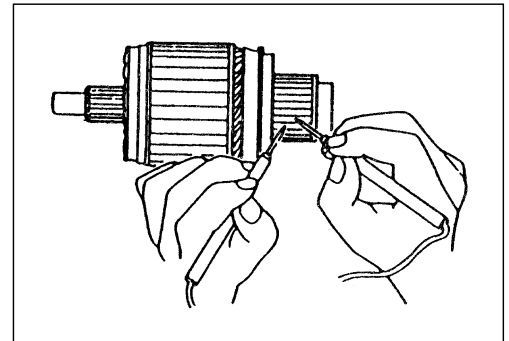

BRUSHES

Measure length of each brush.

 **09900-20101 : Vernier calipers**

Brush length:

Standard : 16.0 mm (0.63 in.)

Service limit : 12.0 mm (0.47 in.)

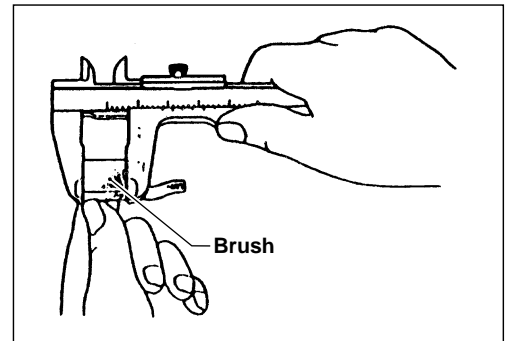

If measurement exceeds service limit, replace brush.



BRUSH HOLDER

Inspect brush holder continuity.

 **09930-99320 : Digital tester**

 **Tester range :  (Continuity)**

Brush holder continuity :

Tester probe connection	Continuity
Brush holder positive ⊕ to Brush holder negative ⊖	No
Brush holder positive ⊕ to Base plate (ground)	No

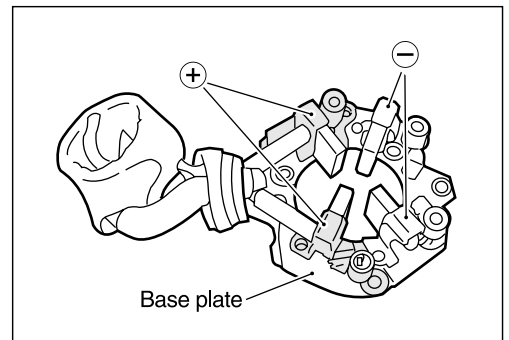

If out of specification, replace brush holder.

BRUSH SPRING

Inspect brush spring for wear or other damage.
Measure brush spring tension.
Replace if necessary.

Brush spring tension

Standard : 15 – 18 N (1.5 – 1.8kg, 3.3 – 4.0 lb.)

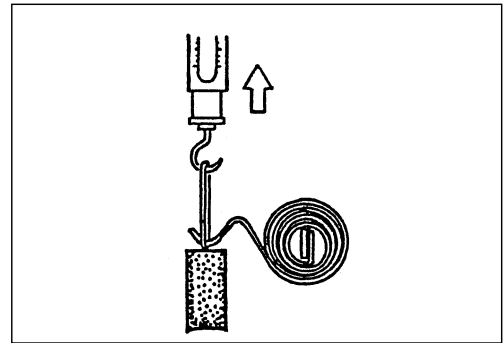

SHIFT LEVER

Inspect shift lever for wear.
Replace if necessary.



PINION AND OVER-RUNNING CLUTCH

Inspect pinion for wear or other damage.
Inspect that clutch locks up when turned in direction of drive
and rotates smoothly in reverse direction.
Replace if necessary.

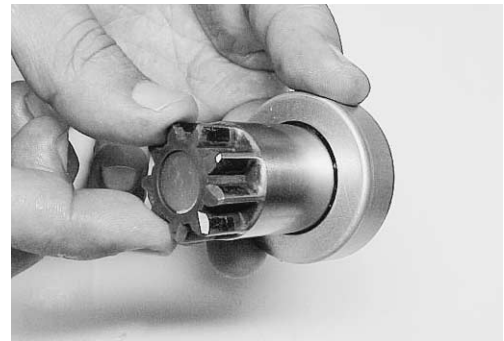

Inspect spline teeth for wear or other damage.
Inspect pinion for smooth movement.
Replace if necessary.



GEAR

Inspect planetary gears and internal gear for wear or other damage.
Replace if necessary.



PINION SHAFT / PINION SHAFT BUSH

Inspect pinion shaft for wear, damage or other abnormal conditions.

Inspect pinion shaft bush for wear or other damage.

Replace if necessary.

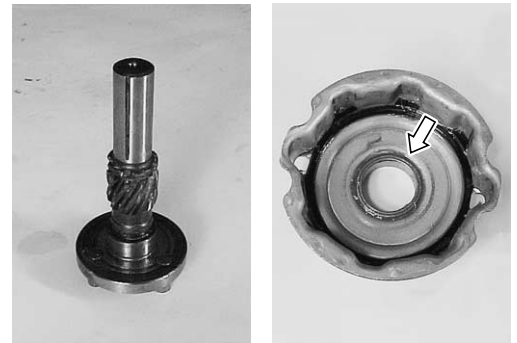
**FRONT HOUSING BEARING**

Inspect bearing for wear or other damage.

Replace if necessary.

**ARMATURE SHAFT BUSH**

Inspect bush for wear or other damage.

Replace if necessary.

**PLUNGER**

Inspect plunger for wear or other damage.

Replace if necessary.



MAGNETIC SWITCH

Push in plunger and release. Plunger should return quickly to its original position.
 Replace if necessary.

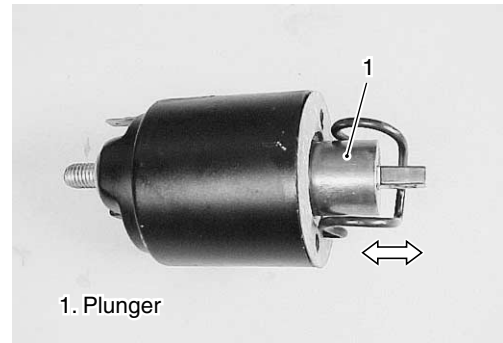

Pull-in coil Open circuit Test

TOOL 09930-99320 : Digital tester

CONT Tester range : (Continuity)

Inspect continuity between terminal“S” and terminal“M” .
 If no continuity exists, replace magnetic switch.

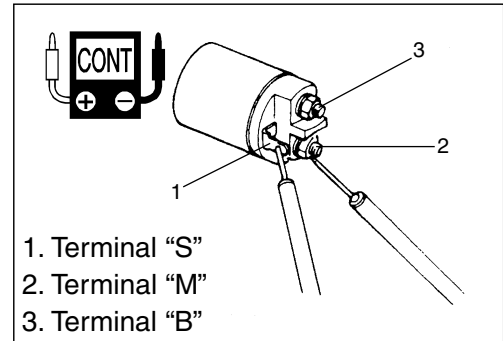

Hold-in coil Open circuit Test

TOOL 09930-99320 : Digital tester

CONT Tester range : (Continuity)

Inspect continuity between terminal“S” and coil case.
 If no continuity exists, replace magnetic switch.

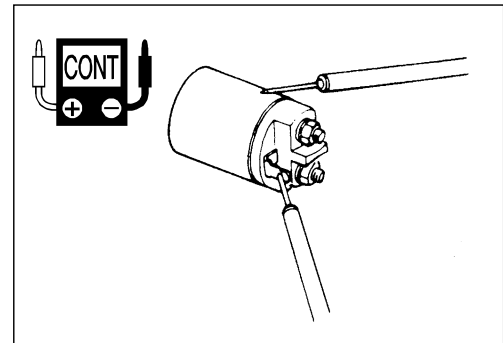

Contact points Test

TOOL 09930-99320 : Digital tester

CONT Tester range : (Continuity)

Put the plunger on under side and then push magnetic switch down.

At this time, inspect continuity between terminal“B” and terminal“M”.

If no continuity exists, replace magnetic switch and/or plunger.

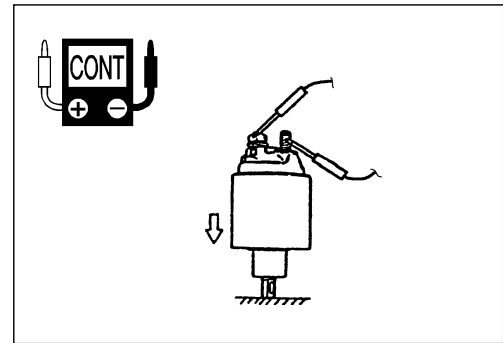

ASSEMBLY

Assembly is reverse order of disassembly with special attention to the following steps.

CAUTION

When installing armature, exercise care to avoid breaking brushes.

When installing pinion shift lever, refer to figure in construction diagram for its installation direction.

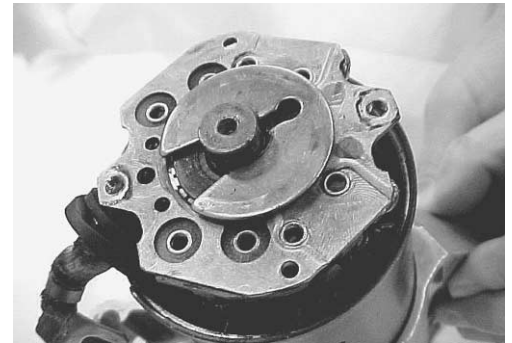
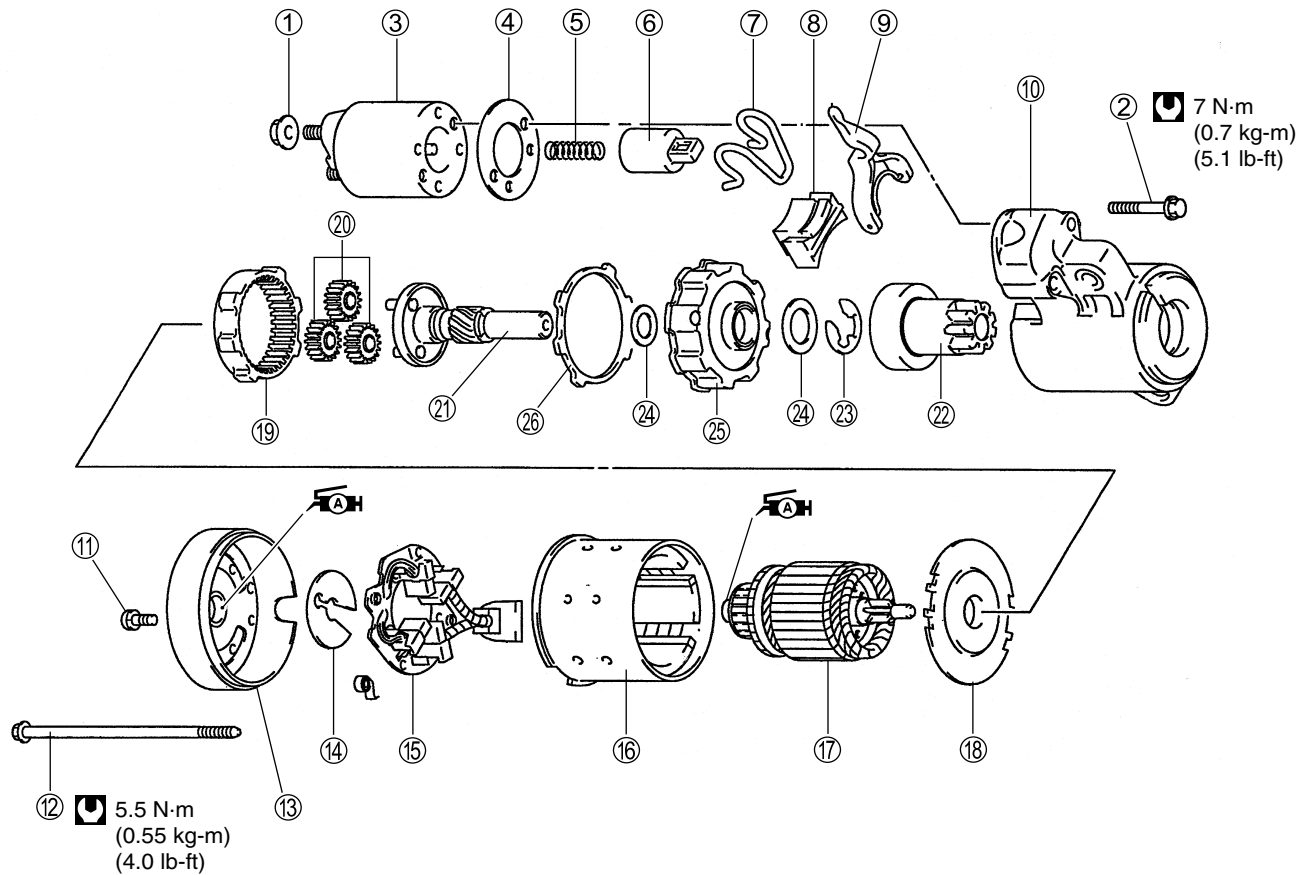
**Construction diagram**

- ① Nut
- ② Bolt
- ③ Magnetic switch
- ④ Gasket
- ⑤ Spring
- ⑥ Plunger
- ⑦ Torsion spring
- ⑧ Rubber packing
- ⑨ Shift lever
- ⑩ Front housing

- ⑪ Screw
- ⑫ Through bolt
- ⑬ Rear cover
- ⑭ Thrust washer
- ⑮ Brush holder
- ⑯ Yoke
- ⑰ Armature
- ⑱ Center cover plate
- ⑲ Internal gear
- ⑳ Planetary gear

- ㉑ Pinion shaft
- ㉒ Pinion
- ㉓ E-ring
- ㉔ Washer
- ㉕ Center bracket
- ㉖ Rubber ring

PERFORMANCE TEST

CAUTION

Each test must be performed within 3 – 5 seconds to avoid coil from burning.

⚠ WARNING

When performing the following test, be sure to connect the battery and the starting motor with a lead wire of the same size as the cable that was originally used there.

PULL-IN / HOLD-IN COIL TEST

Connect battery to magnetic switch as shown in figure.

1. Check that plunger and pinion (over-running clutch) move outward.
If plunger and pinion don't move, replace magnetic switch.

NOTE:

Before testing, disconnect brush lead from terminal "M".

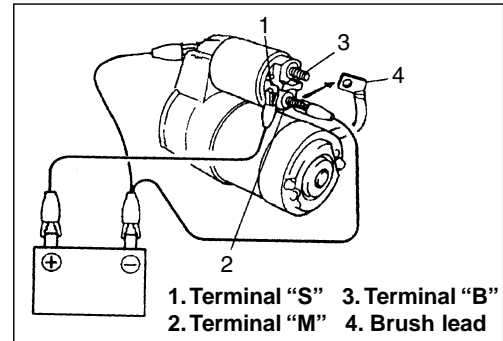

2. While connected as above with plunger out, disconnect negative lead from terminal "M".
Check that plunger and pinion remain out.
If plunger and pinion return inward, replace magnetic switch.

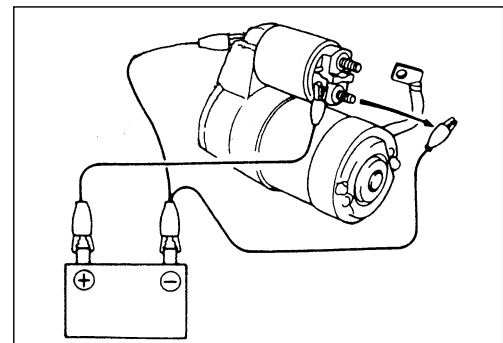

PLUNGER AND PINION RETURN TEST

Disconnect negative lead from switch / motor body.

Check that plunger and pinion return inward.

If plunger and pinion don't return inward, replace magnetic switch.

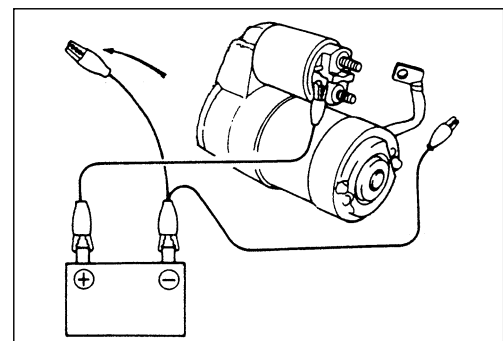

NO-LOAD PERFORMANCE TEST**CAUTION**

Before performing following test, set starter motor securely on test bench.

1. Connect battery and ammeter to starter motor as shown.
2. Check that starter rotates smoothly and steadily with pinion moving out. Check that ammeter indicates specified current.

No load current : Within 90 A at 11 V

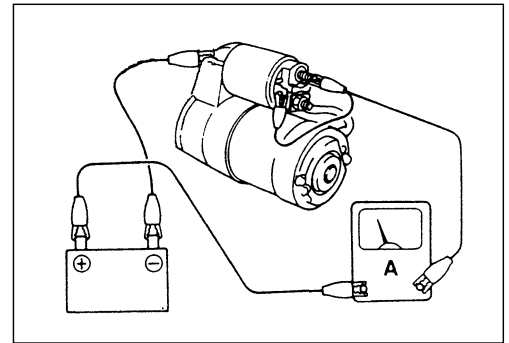

MONITOR-TACHOMETER

INSPECTION

MONITOR LAMP CHECK

1. Connect test cord as shown in figure .

TOOL 09930-89240 : 4-pin test cord

NOTE:

This check can be performed without test cord (P/no. 09930-89240). If it is not available, directly connect battery to terminal of meter.

2. Apply 12V power to meter. Connect Gray wire to positive ⊕ terminal, and Black wire to negative ⊖ terminal of battery.

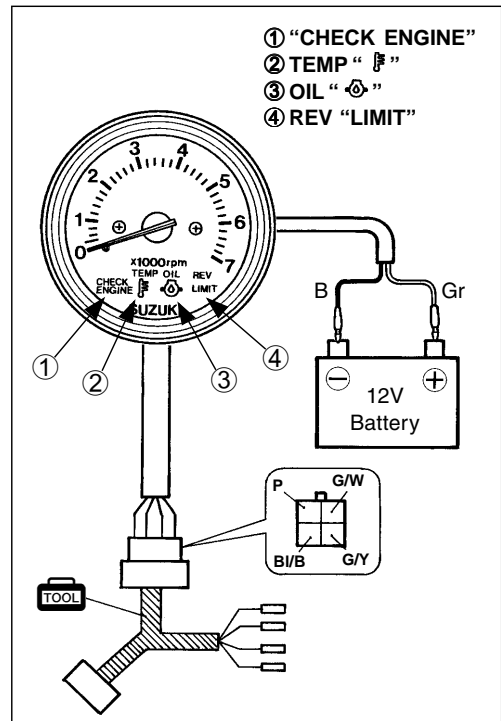

3. Check if lamp lights when connecting battery to test cord terminal as shown.

Monitor lamp check :

Battery terminal	Terminal for battery connection		Lighting lamp
	Test cord	Meter	
Negative ⊖	Bl	G/W	Lamp ①
Negative ⊖	W	G/Y	Lamp ②
Negative ⊖	Y	Bl/B	Lamp ③
Positive ⊕	R	P	Lamp ④

If out of specification, replace monitor-tachometer.

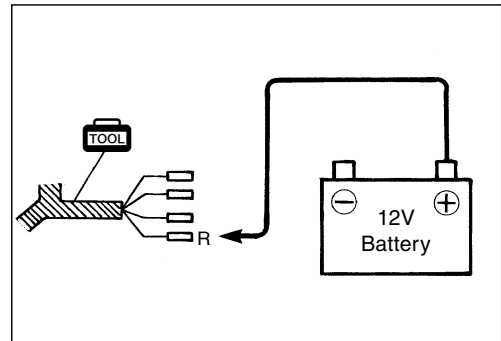
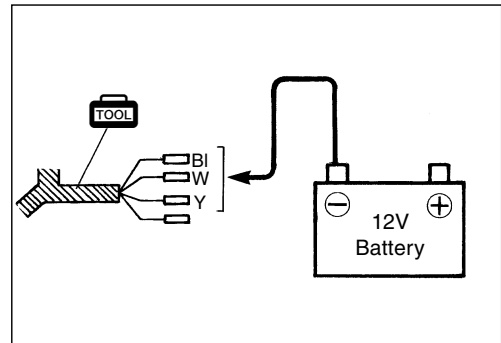

ELECTRIC PARTS HOLDER REMOVAL

Before removing electric parts holder :

- Disconnect battery cables from battery.
- Remove PORT side cover.

1. Remove electric parts holder cover.
2. Remove three bolts and silencer case ①.
3. Disconnect lead wire connector from ECM, then remove ECM.
4. Disconnect following lead wire in electric parts holder.
 - Connector of Rectifier & regulator (W).
 - Connector of CKP sensor.
 - Connector of Ex-mani sensor.
 - Connector of ECM main relay.
 - Connector of starter relay.
 - Red lead wire on 60A main fuse upside terminal.
 - White 30A fuse lead and White Rectifier & Regulator lead wire on 60A main fuse lower side terminal.
 - Pink and Light blue lead wires of PTT motor relay.
 - Blue lead wire on PTT motor relay terminal.
 - Green lead wire on PTT motor relay terminal.
 - Red lead wire on Up PTT motor relay terminal.
5. Remove bolt securing starter motor band, then remove negative battery cable and main harness GND lead.
6. Disconnect Red lead wire from terminal“S” on starter motor.
7. Pull out 30A fuse case from electric parts holder.
8. Remove bolt, GND lead wire and electric parts holder.

NOTE:

To remove electric parts holder, first, slide bottom side of electric parts holder to the left, then slide parts holder toward direction of ten (10) o'clock.

INSTALLATION

Installation is reverse order of removal.
See page 10-2 to 10-7 for check of wire routing.

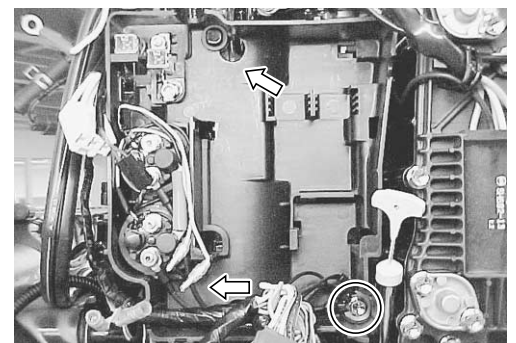
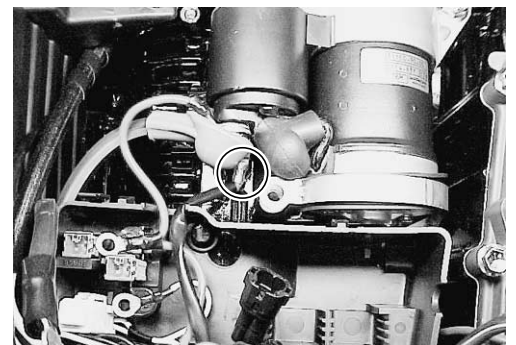
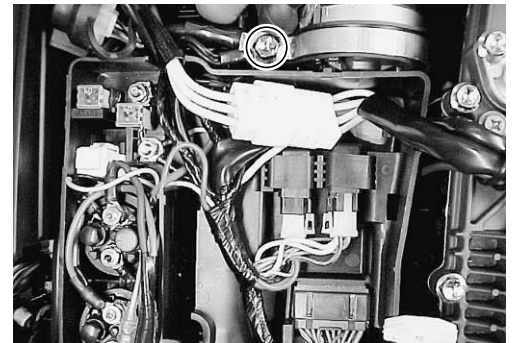
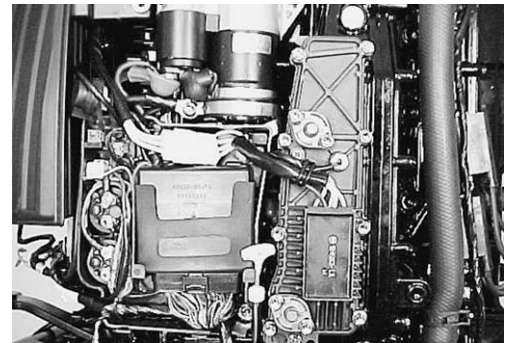
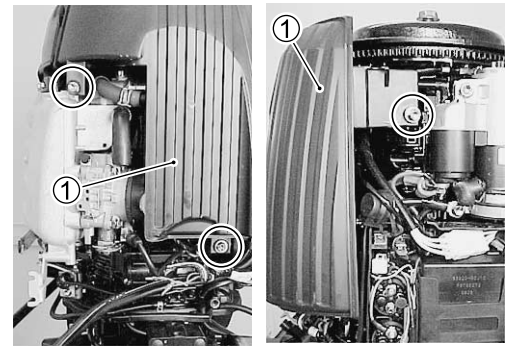

FUEL SYSTEM

CONTENTS

PRECAUTION ON FUEL SYSTEM SERVICE	5-2
GENERAL PRECAUTION	5-2
FUEL PRESSURE RELIEF PROCEDURE	5-3
FUEL LINE	5-4
REMOVAL / INSTALLATION	5-4
FUEL LEAKAGE CHECK PROCEDURE	5-4
FUEL HOSE CONNECTION	5-5
FUEL PRESSURE INSPECTION	5-5
FUEL VAPOR SEPARATOR / HIGH PRESSURE FUEL PUMP	5-7
REMOVAL / INSTALLATION	5-7
DISASSEMBLY	5-8
INSPECTION	5-9
ASSEMBLY	5-10
FUEL INJECTOR	5-12
INSPECTION	5-12
REMOVAL	5-12
INSTALLATION	5-13
LOW PRESSURE FUEL PUMP	5-14
REMOVAL / INSTALLATION	5-14
DISASSEMBLY / REASSEMBLY	5-15
INSPECTION	5-16
FUEL TANK	5-17
DISASSEMBLY / REASSEMBLY	5-17
INSPECTION	5-18

PRECAUTION ON FUEL SYSTEM SERVICE

GENERAL PRECAUTION

⚠ WARNING

Gasoline is extremely flammable and toxic. Always observe the following precautions when working around gasoline or servicing the fuel system.

- Disconnect battery cables except when battery power is required for servicing / inspection.
- Keep the working area well ventilated and away from open flame (such as gas heater) or sparks.
- Do not smoke or allow anyone else to smoke near the working areas.
Post a “NO SMOKING” sign.
- Keep a fully charged CO₂ fire extinguisher and readily available for use.
- Always use appropriate safety equipment and wear safety glasses when working around pressurized fuel system.
- To avoid potential fire hazards, do not allow fuel to spill on hot engine parts or on operating electrical components.
- Wipe up fuel spills immediately.

⚠ WARNING

The components after the high pressure fuel pump remain pressurized at all times.

To protect against fuel spray, relieve fuel line pressure before disconnecting or removing components.

FUEL PRESSURE RELIEF PROCEDURE

After making sure that engine is cold, relieve fuel pressure as follows.

1. Turn OFF ignition switch.
2. Disconnect high pressure fuel pump lead wire connector at high pressure fuel pump.

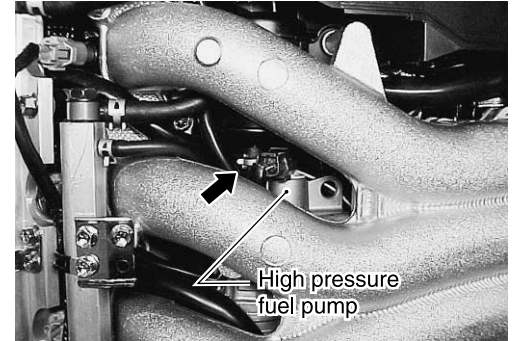

3. Disconnect ignition coil primary lead wire connector from all ignition coils.
4. Crank engine 5 – 10 times (3 seconds each time) to dissipate fuel pressure in lines.

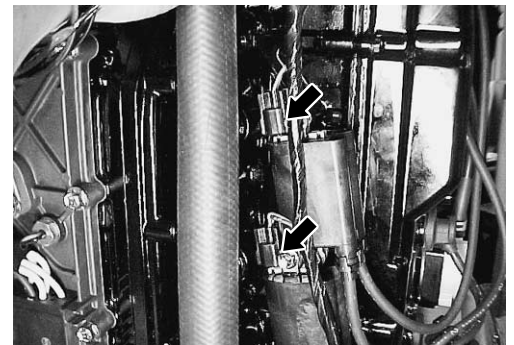

5. Make sure fuel pressure has been removed by pinching high pressure fuel hose with finger tips (line should feel soft without pressure).
6. Upon completion of servicing, connect ignition coil primary lead wire and high pressure fuel pump lead wire.

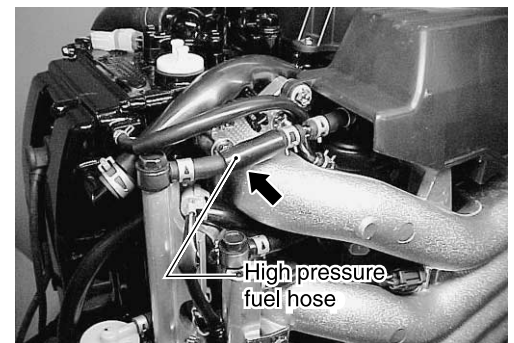

FUEL LINE REMOVAL / INSTALLATION

Pay special attention to the following steps when removing or installing fuel hoses.

⚠ WARNING

The components after the high pressure fuel pump remain pressurized at all times.

To protect against fuel spray, relieve fuel line pressure before disconnecting or removing components.

CAUTION

- Do not over bend (kink) or twist hoses when installing.
- When installing hose clamps, position tabs to avoid contact with other parts.
- Be sure hoses do not contact rods, levers or other components with engine either operating or at rest.
- Extreme care should be taken not to cut, abrade or cause any other damage to hoses.
- Use care not to excessively compress hoses when tightening clamps.

NOTE:

- Check fuel hose routing. (See page 10-8 and 10-11)
- Check for fuel leakage.

FUEL LEAKAGE CHECK PROCEDURE

After performing any fuel system service, always be sure there is not fuel leakage by checking as follows.

1. Squeeze fuel primer bulb until you feel resistance.
2. Turn ignition switch "ON" for 3 seconds (to operate fuel pump), then turn it "OFF". Repeat this (ON and OFF) procedure 3 or 4 times to pressurize fuel system.
3. Once pressurized, check all connections and components for any signs of leakage.

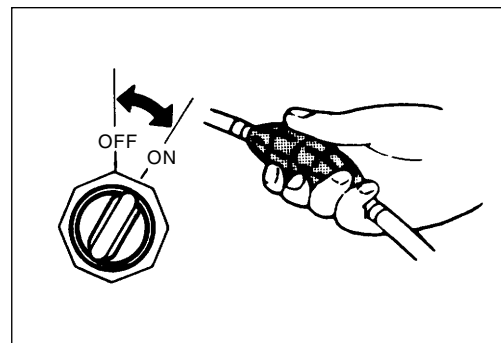

FUEL HOSE CONNECTION

Note that fuel hose connection varies with each type of pipe. Be sure to connect and clamp each hose correctly by referring to following figures.

- For type “A” (short barbed end) pipe, hose should completely cover pipe.
- For type “B” (bent end) pipe, hose should cover straight part of pipe by 20 – 30mm (0.8 – 1.2 in.).
- For type “C” pipe, hose should fit up against flanged part of pipe.
- For type “D” pipe, hose should cover pipe by 20 – 30 mm (0.8 – 1.2 in.).

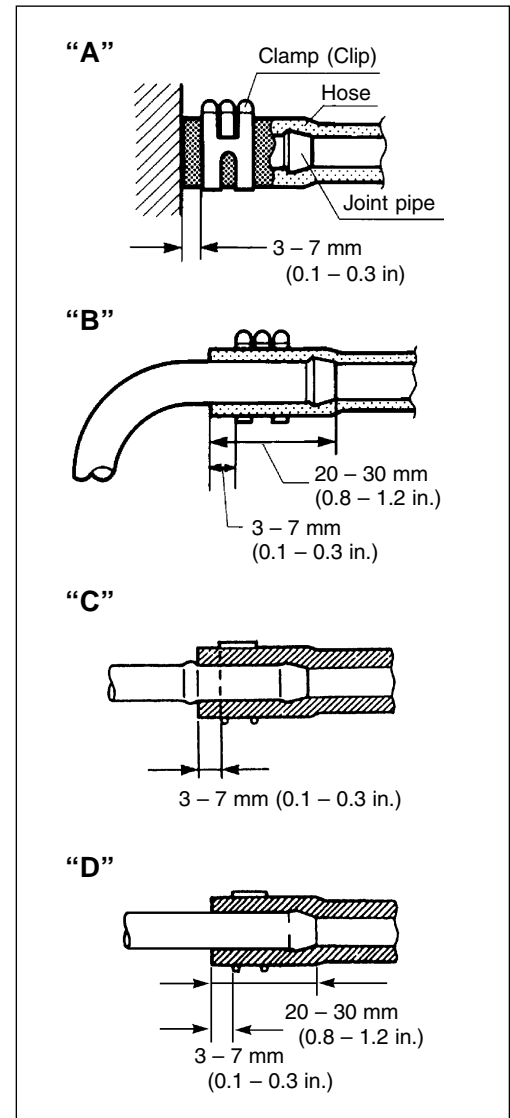

FUEL PRESSURE INSPECTION

1. Relieve fuel pressure in fuel feed line. (See page 5-3.)
2. Loosen delivery pipe upper plug.
3. Connect special tools (pressure gauge, pressure hose & pressure joint) between fuel feed hose and delivery pipe as shown in figure.
Tighten delivery pipe upper plug to specified torque.
Clamp hose securely to ensure no leaks occur during checking.

-  **09912-58442 : Pressure gauge – ①**
- 09912-58432 : Fuel pressure hose – ②**
- 09912-58490 : Fuel pressure joint – ③**

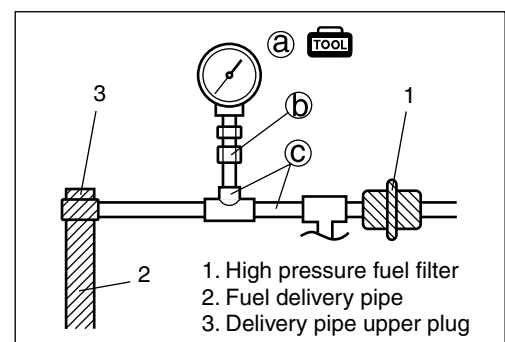

CAUTION

A small amount of fuel may be released when the fuel feed hose is disconnected. Place container under the fuel feed hose with a shop cloth so that released fuel is caught in container or absorbed in cloth. Place fuel soaked cloth in an approved container.

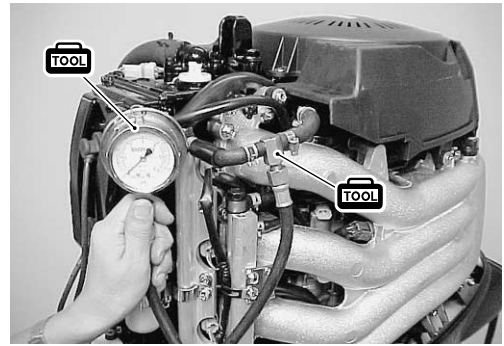

Delivery pipe upper plug :
35 N m (3.5 kg-m, 25.5 lb.-ft.)

4. Squeeze fuel primer bulb until you feel resistance. Turn ignition switch "ON" for 3 seconds (to operate fuel pump), then turn it "OFF". Repeat this ("ON" and "OFF") procedure 3 or 4 times to pressurize fuel system and then check fuel pressure.

5. Measure fuel pressure in line at cranking or idle speed operation.

**Fuel pressure : Approx. 255 kPa
 (2.55 kg/cm², 36.3 psi)**

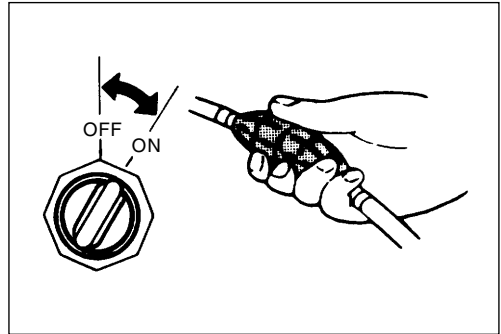

6. Stop engine and wait 5 minutes.
7. Read residual fuel pressure in line.

**Residual fuel pressure : 200 kPa (2.0 kg/cm², 28.4 psi)
 or higher**

CAUTION

As fuel feed line is still under high fuel pressure, make sure to release fuel pressure according to following procedures.

- Place container under joint to catch fuel.
- Cover joint with rag and loosen joint nut slowly to gradually release fuel pressure.

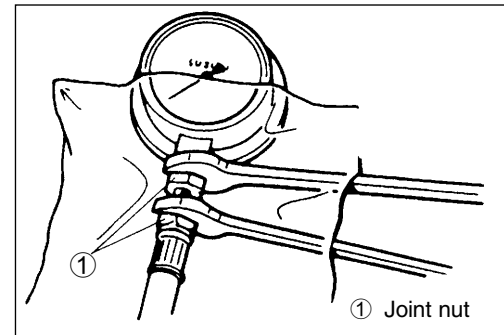

8. After measuring fuel pressure, remove fuel pressure gauge.
9. Reconnect fuel line.
10. With engine not running and ignition switch "ON", check fuel system for leaks.

FUEL VAPOR SEPARATOR / HIGH PRESSURE FUEL PUMP REMOVAL / INSTALLATION

REMOVAL

⚠ WARNING

The components after the high pressure fuel pump remain pressurized at all times.
To protect against fuel spray, relieve fuel line pressure before disconnecting or removing components.

1. Remove intake manifold assembly.
(See page 6-2)

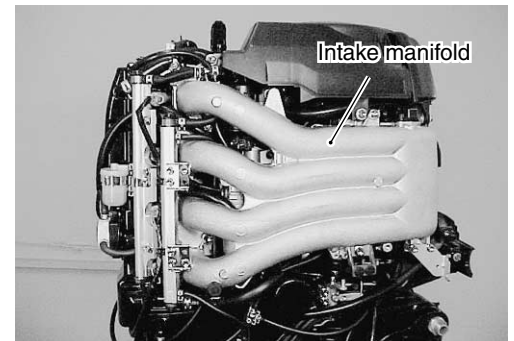

2. Remove three bolts and fuel vapor separator assembly from intake manifold.
3. Disconnect fuel outlet hose from fuel vapor separator.

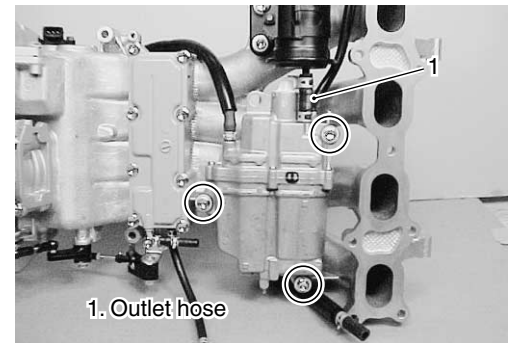

INSTALLATION

Installation is reverse order of removal.

See page 6-4 for installation of intake manifold assembly.

DISASSEMBLY

1. Remove five screws ①.
2. Remove separator cover ② with high pressure fuel pump from separator case ③.

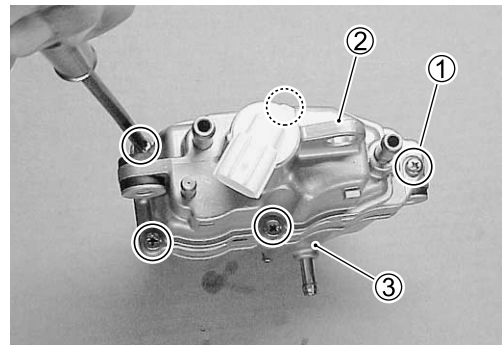

3. Remove float pin ④ and float ⑤.

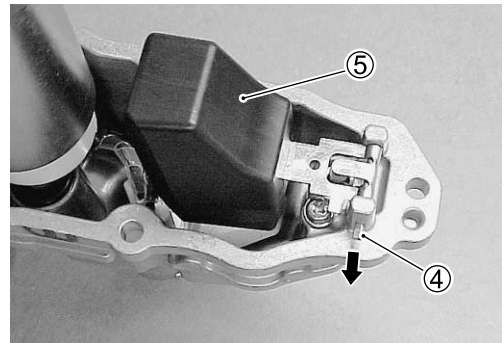

4. Remove needle valve ⑥, screw ⑦, plate and valve seat ⑧.

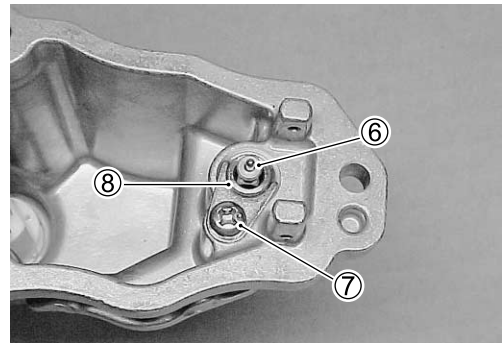

5. Remove screw and fuel pressure regulator ⑨ from separator case.

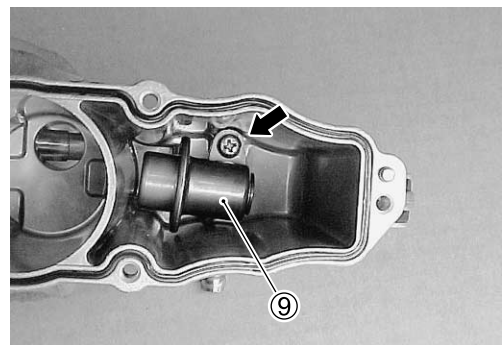

6. Remove suction filter ⑩.

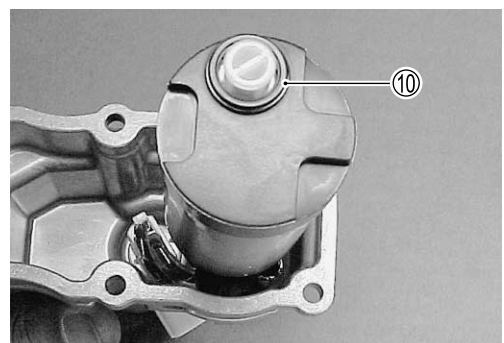

- Remove high pressure fuel pump ⑪ and grommet ⑫ from separator cover and then disconnect pump lead wire connector.

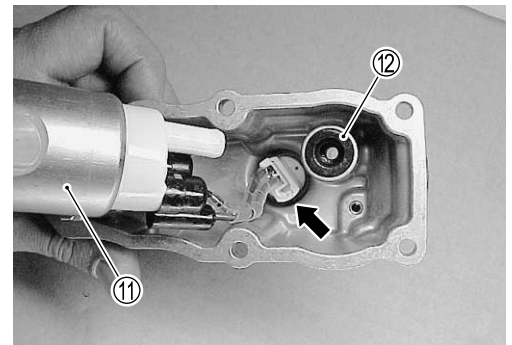

INSPECTION

NOTE:

If cracks, excessive wear or other damage is found on any component, replace component.

Needle valve / Valve seat

Inspect needle valve and valve seat for groove, other damage or dirt.

Replace or clean if necessary.

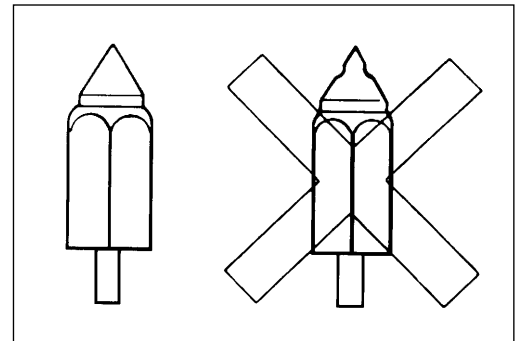

Float

Inspect float for crack or other damage.

Replace if necessary.

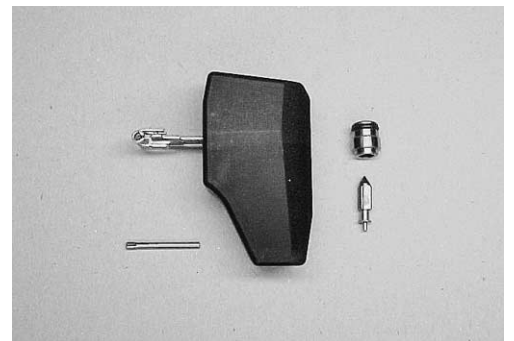

Filter

Inspect pump suction filter for clog or other damage.

Replace or clean if necessary.



Fuel pressure regulator

Check fuel pressure regulator operation.

-  : Hand air pump ①
- 09940-44121 : Air pressure gauge ②
- 09940-44130 : Attachment ③
- 09912-58490 : Hose ④

1. Connect special tools to inlet side of regulator as shown in figure.
2. Pump air into regulator using pump ① until air is released through outlet side.
3. Read pressure on gauge when air is released.

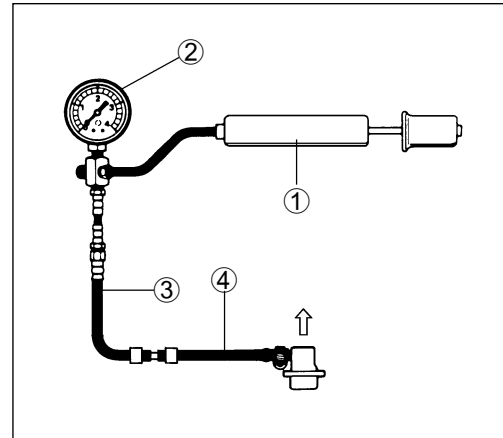

Regulator operating pressure :

240 – 270 kPa (2.4 – 2.7 kg/cm², 34.1 – 38.4 psi)

If out of specification, replace regulator.

ASSEMBLY

Assembly is reverse order of disassembly with special attention to the following steps.

High pressure fuel pump

Connect pump lead wire connector, then install grommet ① and fuel pump ②.

NOTE:

Apply fuel to grommet before installing.

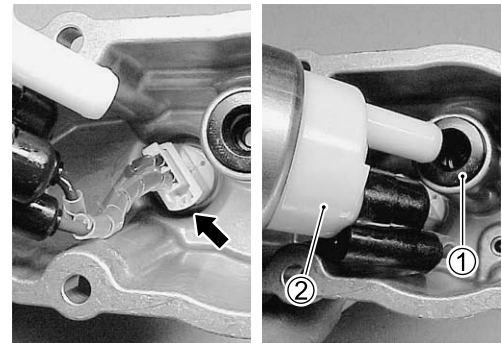

Float / Float pin

Install float and float pin.

NOTE:

After assembling, check for smooth and free float movement.

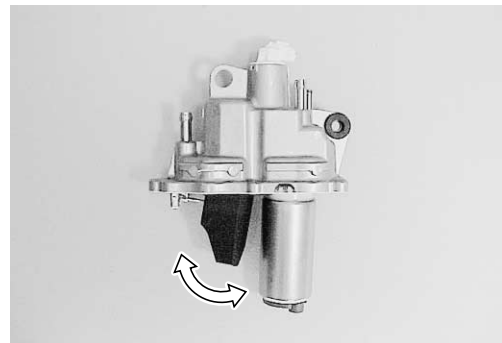

Checking float height

Measure float height.

-  09900-20101 : Vernier calipers

Float height H : 43 ± 1 mm

NOTE:

Make sure that float weight is not applied to needle valve.

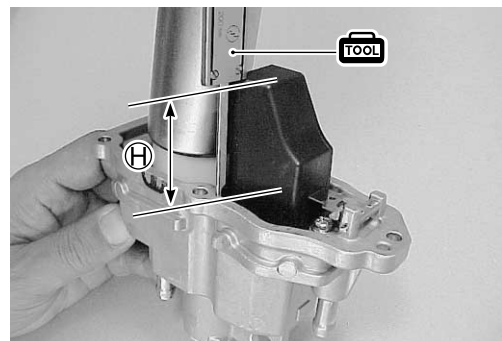

Setting float height

To correct specification, bend only adjustment tab ①.

CAUTION

When adjusting tab, do not bend to the point that it applies pressure to the needle and seat.

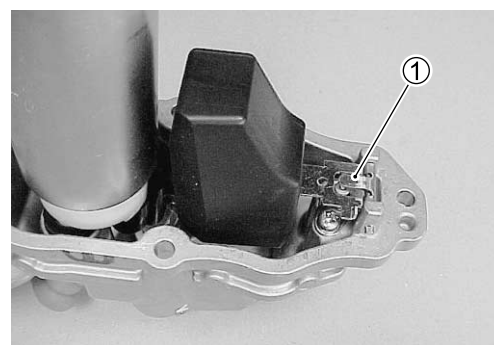

Fuel pressure regulator

Install fuel pressure regulator and tighten screw securely.

NOTE:

Apply fuel to O-ring before installing regulator.



Separator cover / Separator case

1. Install seal ring ①, then apply Suzuki Bond evenly to only the outside mating surface of separator case as shown in figure.

 99000-31140 : Suzuki Bond 1207B

NOTE:

- Clean mating surfaces before applying bond.
- Do not apply bond to seal ring, groove and inside mating surface.

2. Install separator case, then tighten screws securely.

NOTE:

When installing separator case, align suction hole ① with hole ② of separator case.

NOTE:

Separator cover and case are a set.

Make sure paint marks on both items are matched when assembling.

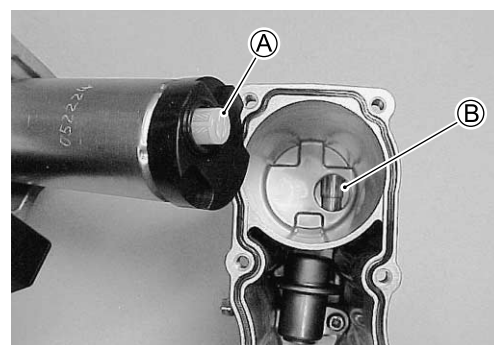
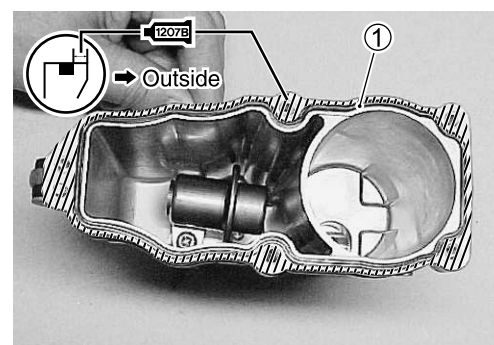

FUEL INJECTOR

INSPECTION

- Using sound scope or equivalent, check operating sound of fuel injector when engine is running or cranking. Injector operating sound cycle should vary according to engine speed.
If no sound or an unusual sound is heard, check injector circuit (wire or connector) or injector.

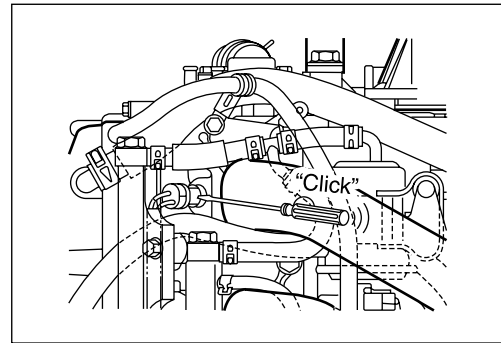

- Disconnect lead wire connector from fuel injector.
- Connect digital tester between terminals of injector and measure resistance.

TOOL 09930-99320 : Digital tester

Tester range : Ω (Resistance)

Fuel injector resistance : 11.0 – 16.5 Ω

If out of specification, replace fuel injector.

- Connect lead wire connector to fuel injector securely.

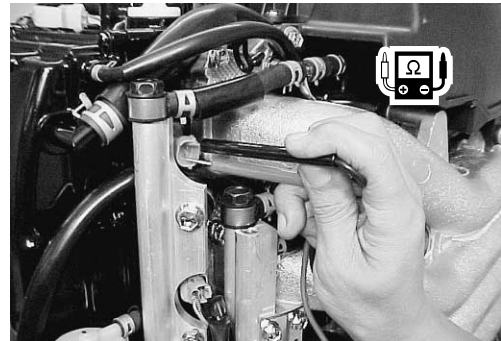

REMOVAL

- Relieve fuel pressure according to procedure described on page 5-3.
- Loosen clamp and place a large cloth over end of fuel feed hose.
Slowly pull fuel feed hose from fuel delivery pipe.
Drain any excess fuel in hose into a small container.
- Disconnect four fuel injector connectors.
- Remove bolts and low fuel filter bracket.
- Remove two bolts and fuel delivery pipe (with fuel injectors).



CAUTION

**A small amount of fuel may be released when the fuel injector is removed from delivery pipe.
Place a shop cloth under fuel injector before removal to absorb any fuel released.
Dispose of fuel soaked cloth in appropriate container.**

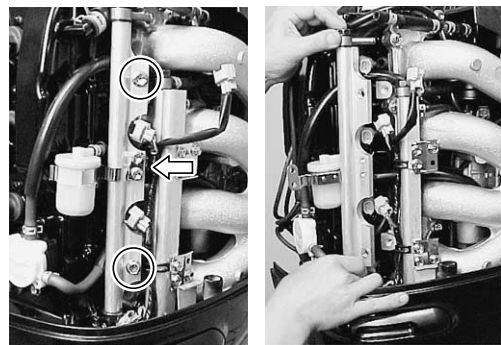

- Remove each injector from delivery pipe.

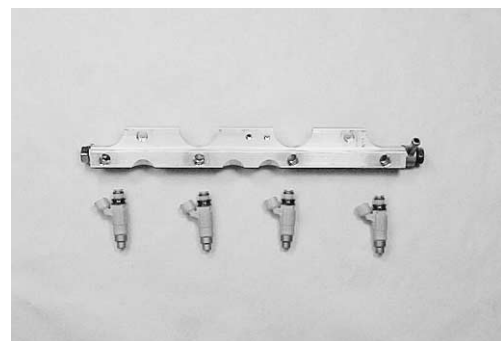

INSTALLATION

Installation is reverse order of removal with special attention to the following steps.

CAUTION

**Do not re-use O-ring and cushion once removed.
Always use new parts.**

1. Replace injector O-ring ① with new one using care not to damage it. Install grommet ② to injector.
2. Place delivery pipe bolts ③ and two (2) insulators (collars) ④ in position.

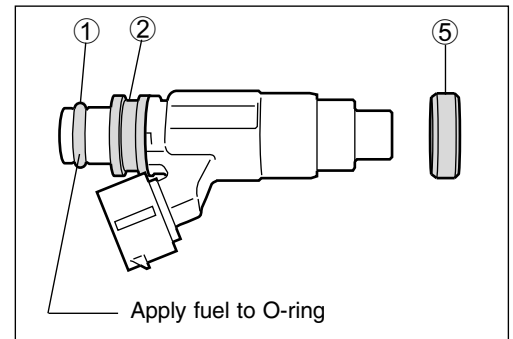

3. Replace injector cushion ⑤ with new one and install it to cylinder head.
4. Apply thin coat of fuel to injector O-rings, then install injectors into delivery pipe ⑥ and cylinder head. Make sure that injectors rotate smoothly.

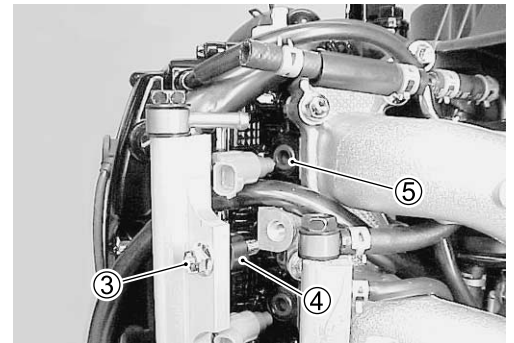

5. Tighten delivery pipe bolt and make sure that injectors rotate smoothly.

 **Fuel delivery pipe bolt : 23 N m (2.3 kg-m, 16.5 lb.-ft.)**

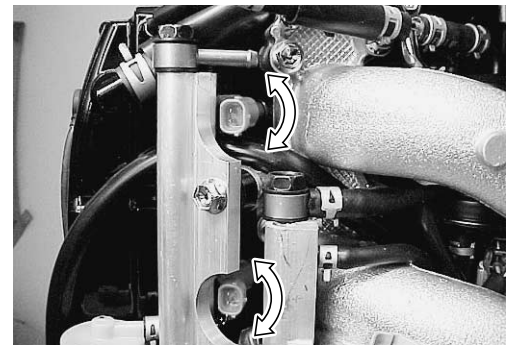

6. Reconnect fuel feed hose to fuel delivery pipe.
7. Connect lead wire connectors to each injector.
8. Turn ignition switch "ON" for 3 seconds (to operate fuel pump), then turn it "OFF". Repeat this (ON and OFF) procedure 3 or 4 times to pressurize fuel system. Check for fuel leaks around fuel injector.

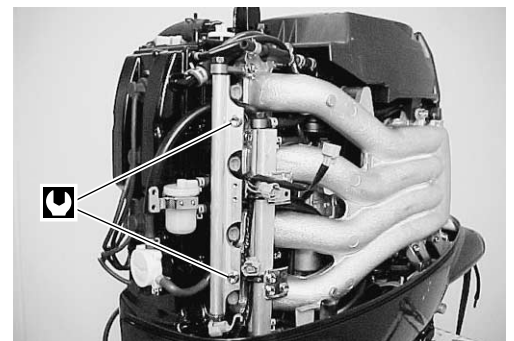

LOW PRESSURE FUEL PUMP

REMOVAL / INSTALLATION

REMOVAL

1. Disconnect inlet hose ① and outlet hose ② from low pressure fuel pump.
2. Remove two bolts ③.
3. Remove fuel pump ④.
Note position before removing O-ring ⑤.

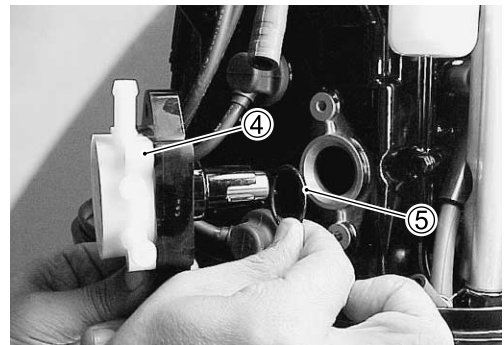
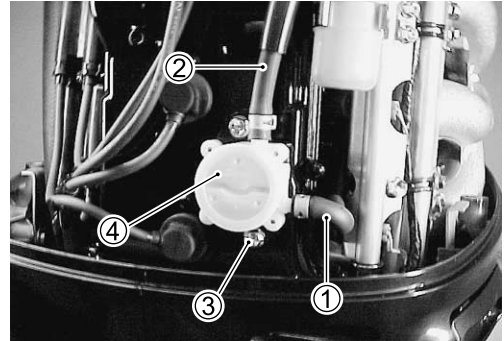

INSTALLATION

Installation is reverse order of removal with special attention to the following steps.

CAUTION

- Before installing fuel pump, rotate the crankshaft to bring No.1 (top cylinder) piston to Top Dead Center on compression stroke.
- Do not re-use O-ring once removed. Always use a new O-ring.

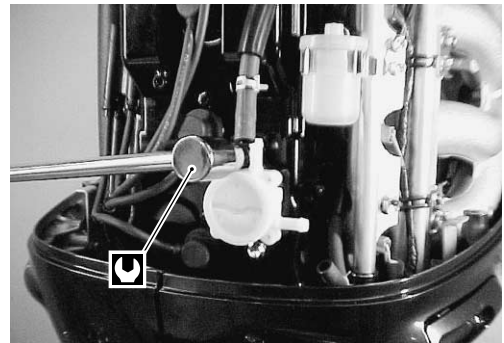

-  Low pressure fuel pump bolt :
10 N m (1.0 kg-m, 7.0 lb.-ft.)



DISASSEMBLY / REASSEMBLY

DISASSEMBLY

NOTE:

For correct assembly, scribe an alignment mark on each part of fuel pump.

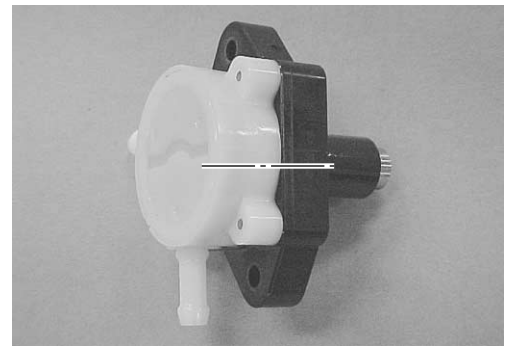

1. Remove four screws ① and valve body assembly ②.
2. Turn piston ③ until pin ④ comes out through cutaway of pump body ⑤.
3. Remove following parts :
 - Pin ④
 - Piston ③
 - Spring ⑥
 - Diaphragm ⑦
 - Spring ⑧

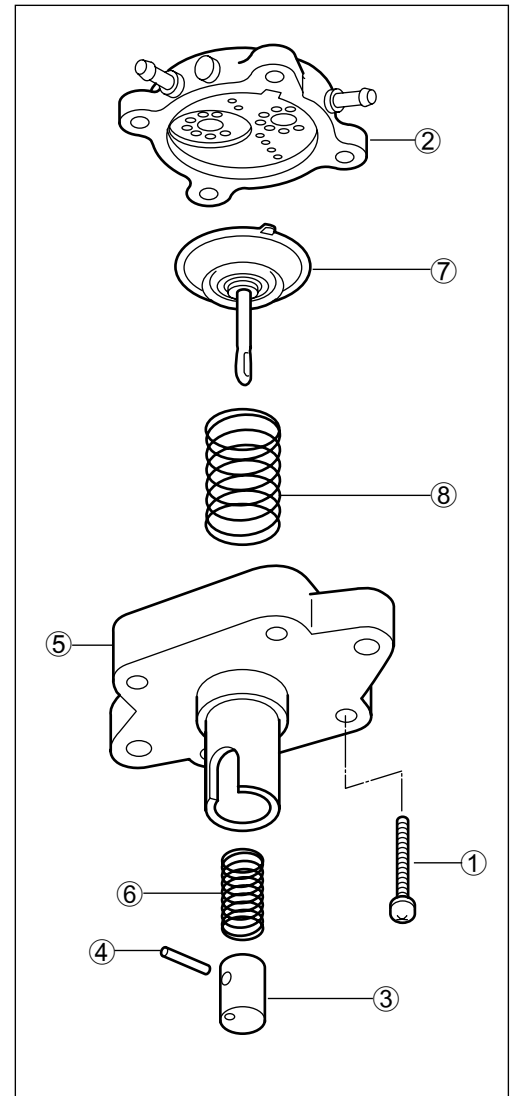

ASSEMBLY

Assembly is reverse order of disassembly with special attention the following steps.

NOTE:

After connecting diaphragm rod ⑦ to piston ③ with pin ④, align projection of diaphragm to groove of pump body by turning piston ③ and diaphragm ⑦ together. Turning them together prevents pin from coming out through pump body ⑤ cutaway.

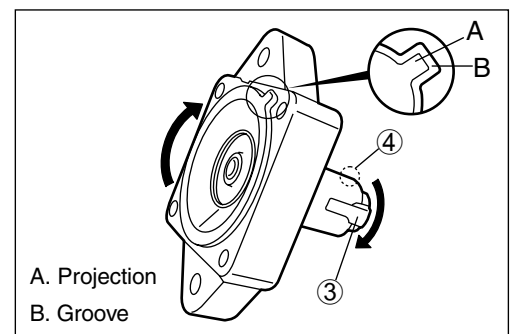

A. Projection
B. Groove

INSPECTION

Diaphragm

Inspect diaphragm for distortion, tears, or other damage.
Replace fuel pump assembly if necessary.



Check-valves

Inspect fuel pump check valves for tears, distortion or damage.
Replace fuel pump assembly if necessary.

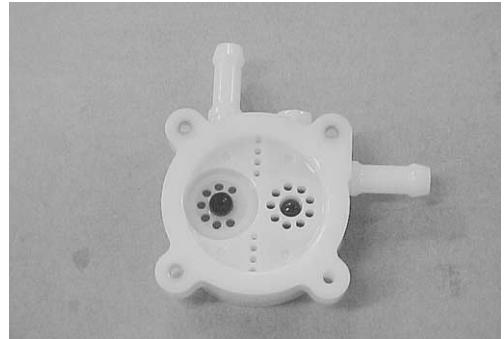

Pump body

Inspect fuel pump body and valve body assembly for cracks, nicks, distortion or other damage.
Replace fuel pump assembly if necessary.



FUEL TANK (OPTIONAL PART) DISASSEMBLY / REASSEMBLY

When disassembling or reassembling fuel tank, refer to the construction diagram below.

Plastic tank

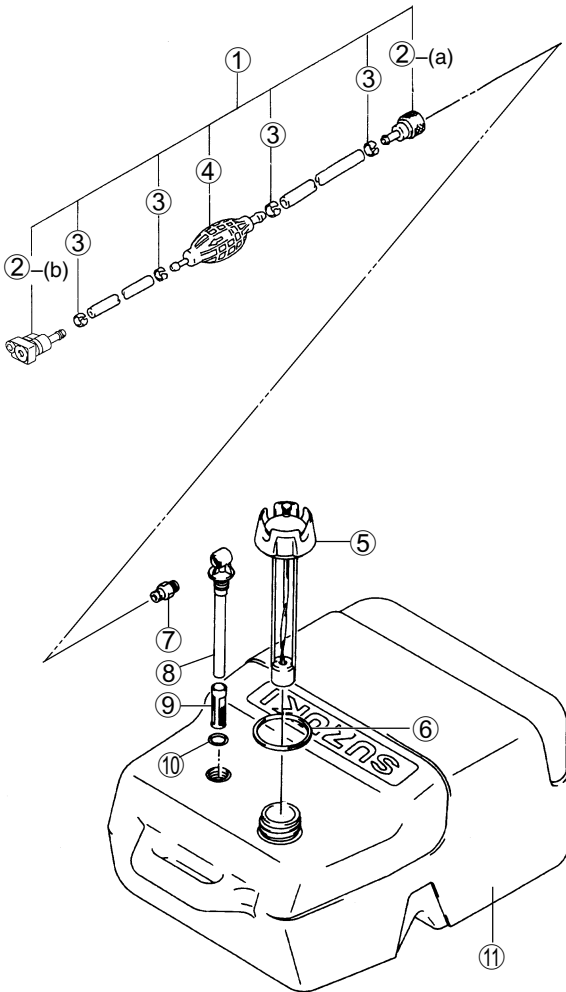

- | | |
|----------------------|----------------------|
| ① Fuel hose assy (1) | ⑦ Connector plug (1) |
| [②-(a), Connector] | ⑧ Outlet (1) |
| [②-(b), Connector] | ⑨ Filter (1) |
| [③ Clip (4)] | ⑩ O-ring (1) |
| [④ Primer bulb (1)] | ⑪ Fuel tank (1) |
| ⑤ Tank cap (1) | |
| ⑥ Gasket (1) | |

Steel tank

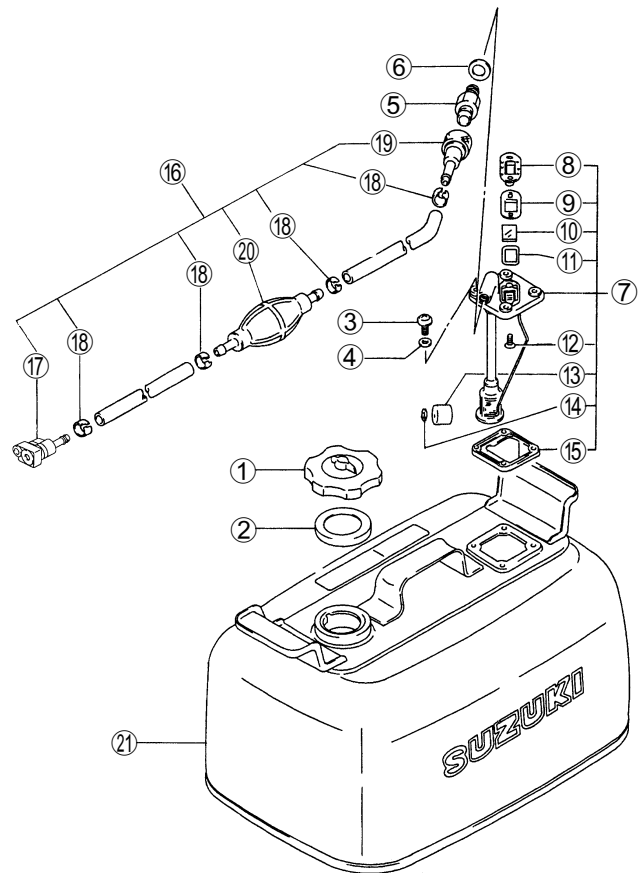

- | | |
|-----------------------|----------------------|
| ① Tank cap (1) | [⑫ Screw (2)] |
| ② Gasket (1) | [⑬ Float (1)] |
| ③ Screw (4) | [⑭ Push nut (1)] |
| ④ Gasket (4) | [⑮ Gasket (1)] |
| ⑤ Connector plug (1) | ⑯ Fuel hose assy (1) |
| ⑥ Gasket (1) | [⑰ Connector (1)] |
| ⑦ Fuel gauge assy (1) | [⑱ Clip (4)] |
| [⑧ Cover (1)] | [⑲ Connector (1)] |
| [⑨ Gasket (1)] | [⑳ Primer bulb (1)] |
| [⑩ Lens (1)] | [㉑ Fuel tank (1)] |
| [⑪ Gasket (1)] | |

INSPECTION

Fuel connector

Inspect fuel connector for leakage, deterioration or other damage.

Replace if necessary.

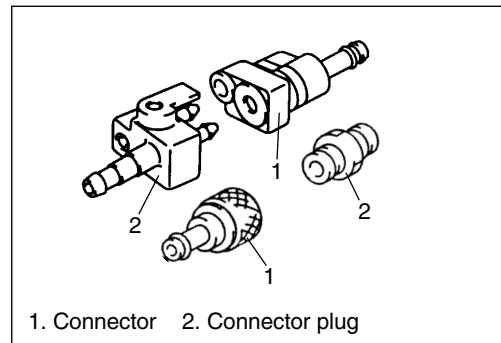

Fuel primer bulb

Inspect fuel primer bulb for cracks, leakage, deterioration or check valve function.

Replace if necessary.

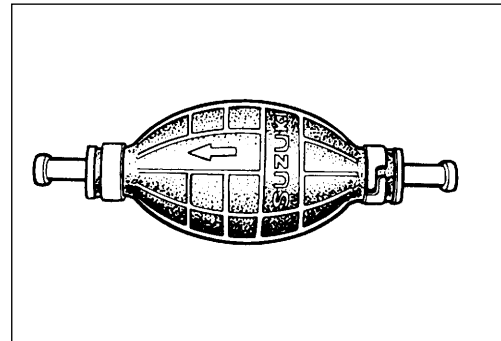

Fuel hose

Inspect fuel hose for cuts, cracks, leakage, tears or deterioration.

Replace if necessary.

Fuel tank

Inspect fuel tank for cracks, leakage or deterioration.

Replace if necessary.

If water or other contamination is found, drain and clean fuel tank.

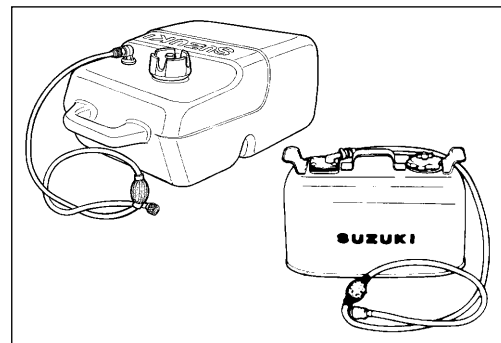

Tank cap

Inspect tank cap for cracks, leakage, deterioration or vent function.

Replace if necessary.

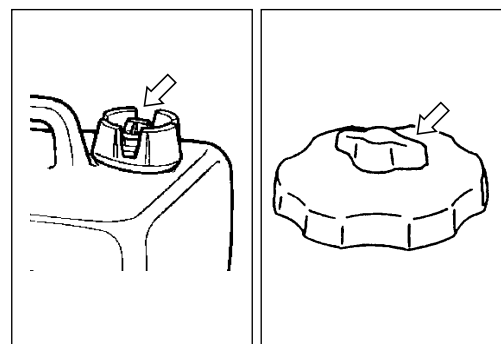

POWER UNIT

CONTENTS

INTAKE MANIFOLD ASSEMBLY _____	6-2
REMOVAL	6-2
INSTALLATION	6-4
POWER UNIT _____	6-5
REMOVAL	6-5
INSTALLATION	6-9
OIL PUMP _____	6-12
REMOVAL	6-12
INSPECTION	6-12
INSTALLATION	6-13
TIMING CHAIN / TENSIONER _____	6-14
REMOVAL	6-14
INSPECTION	6-16
INSTALLATION	6-17
CYLINDER HEAD ASSEMBLY _____	6-20
REMOVAL	6-20
INSTALLATION	6-21
DISASSEMBLY	6-24
INSPECTION / SERVICING	6-25
REASSEMBLY	6-38
CYLINDER / CRANKSHAFT / PISTON _____	6-40
DISASSEMBLY	6-40
INSPECTION / SERVICING	6-43
REASSEMBLY	6-57
THERMOSTAT _____	6-63
REMOVAL / INSPECTION / INSTALLATION	6-63
OPERATION _____	6-64
WATER COOLING SYSTEM	6-64
ENGINE LUBRICATION SYSTEM	6-65

INTAKE MANIFOLD ASSEMBLY REMOVAL

Before removing intake manifold :

- Relieve fuel pressure. (See page 5-3)
- Disconnect battery cables from battery.
- Remove both side covers. (See page 7-2)

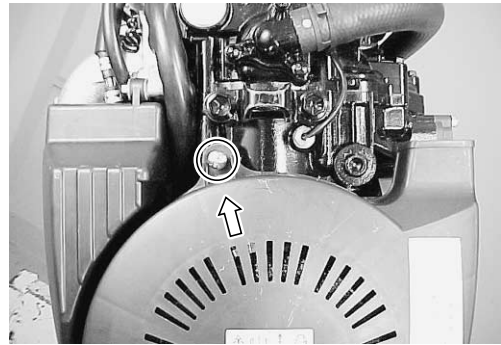

1. Remove flywheel cover.
2. Remove two bolts and air duct ①.
3. Remove evaporation hose ② from cylinder head cover.

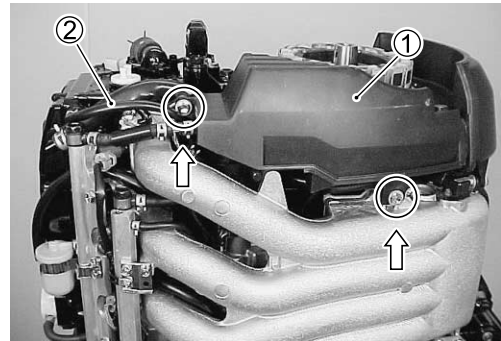

4. Disconnect fuel outlet hose ③ and fuel inlet hose ④ from low pressure fuel pump.

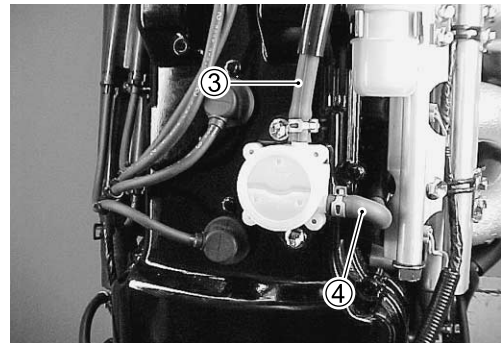

5. Loosen clamp and place a large cloth over end of fuel feed hose ⑤.
Slowly pull fuel feed hose from fuel delivery pipe ⑥.
Drain any excess fuel in hose into a small container.

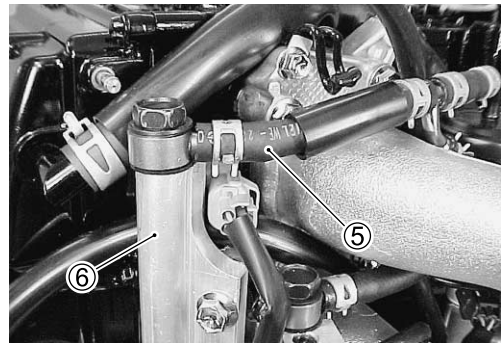

6. Disconnect four fuel injector connectors ⑦.
7. Disconnect high pressure fuel pump connector ⑧ from fuel vapor separator.

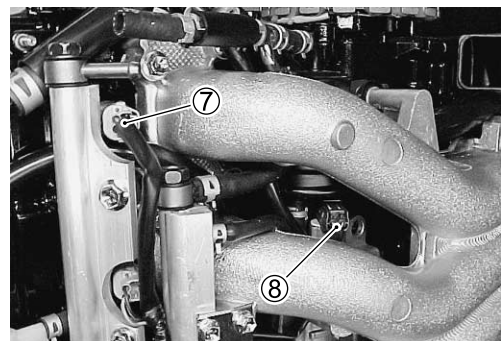

8. Remove bolts and low pressure fuel filter bracket ⑨.
9. Remove two (2) bolts securing fuel delivery pipe ⑥, then remove fuel delivery pipe and all fuel injectors ⑩.

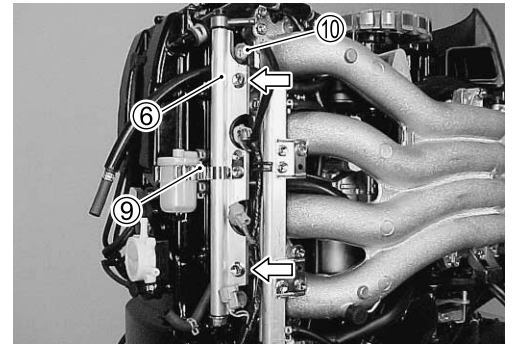

10. Remove two (2) bolts and fuel return pipe ⑪.
11. Disconnect water inlet hose ⑫ and water outlet hose ⑬ from fuel return pipe.
12. Place a suitable container under fuel return pipe, then disconnect fuel inlet hose ⑭ and fuel outlet hose ⑮ from fuel return pipe.

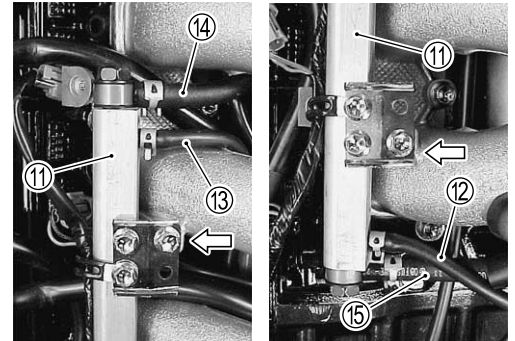

13. Remove three (3) bolts and silencer case ⑮.
14. Disconnect breather hose ⑯ from silencer case.
15. Disconnect IAT sensor connector ⑰.

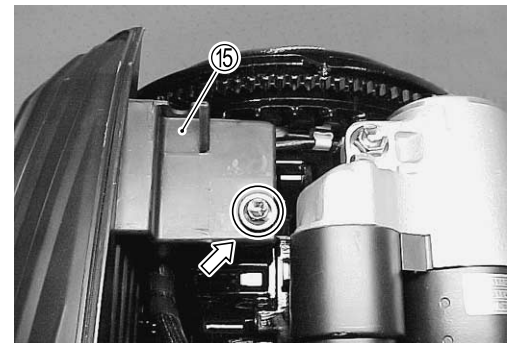
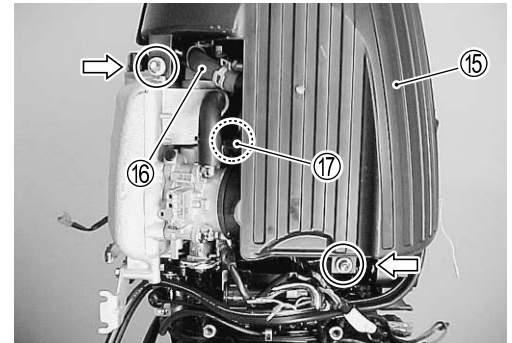

16. Disconnect CTP switch connector ⑱.
17. Disconnect IAC valve connector ⑲.
18. Disconnect MAP sensor connector ⑳.

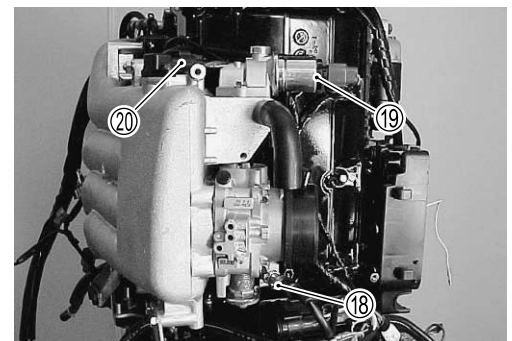

6-4 POWER UNIT

19. Disconnect water inlet hose ②① and water outlet hose ②② from 3-way joint.

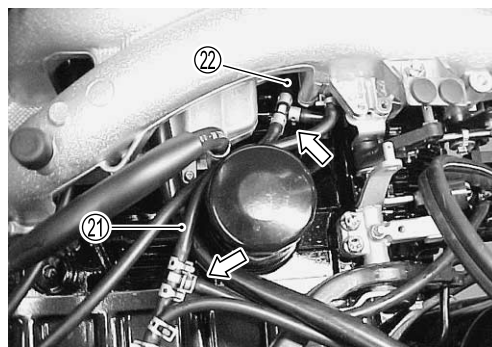

20. Remove nine (9) bolts and two (2) nuts and then remove intake manifold assembly ②③.

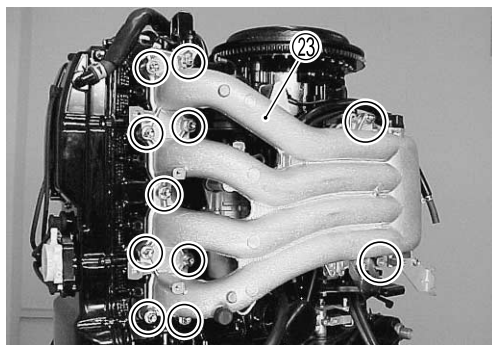

INSTALLATION

Installation is reverse order of removal with special attention to the following steps.

CAUTION

Do not re-use gasket once removed. Always use a new gasket.

- Install two dowel pins ①, gasket ② and intake manifold assembly, then tighten bolts and nuts securely.

Intake manifold bolt & nut :

23 N·m (2.3 kg-m, 16.5 lb.-ft.)

- Install fuel injectors and fuel delivery pipe. (See page 5-13)
- Check to ensure that all removed parts are back in place.

Checking

- Check fuel and water hose routing. (See page 10-8 to 10-11)
- Check wire routing. (See page 10-2 to 10-7)
- Check for fuel leakage. (See page 5-4)
- Check for water leakage.

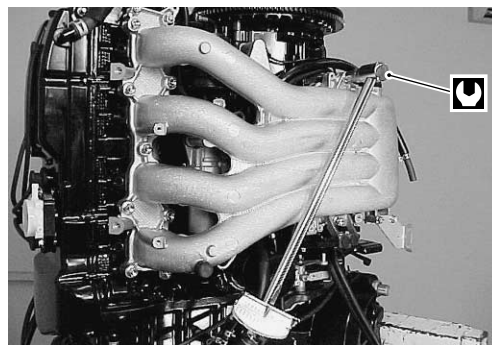
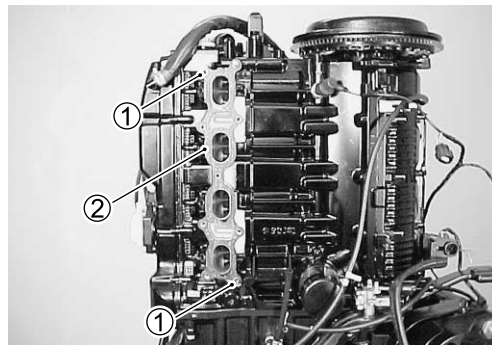

POWER UNIT

REMOVAL

Before removing power unit :

- Drain engine oil. (See page 2-4)
- Remove intake manifold assembly. (See page 6-2)
- Remove electric parts holder. (See page 4-25)

1. Remove bolts and fuel pump ①.

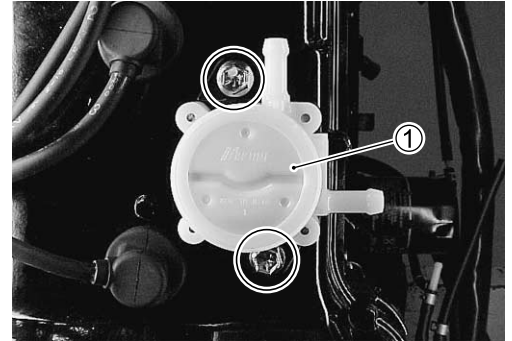

2. Remove all spark plugs.
3. Remove fifteen (15) cylinder head cover bolts, and then remove cylinder head cover ②.

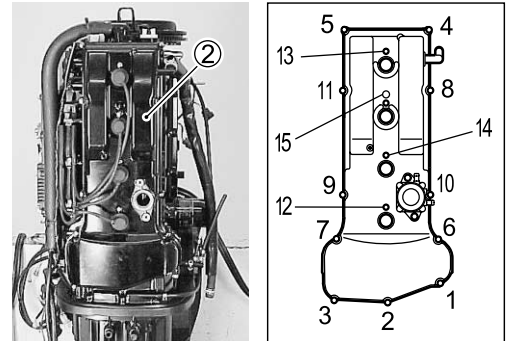

4. Remove nut and positive battery cable ③.
5. Remove starter motor. (See page 4-12)

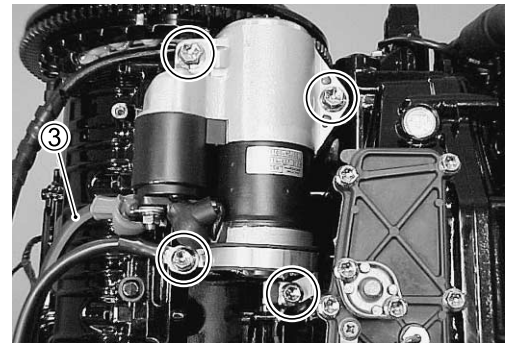

6. Remove flywheel. (See page 3-51)

- TOOL** 09930-48720 : Flywheel holder
09930-39411 : Flywheel remover
09930-39420 : Flywheel remover bolt

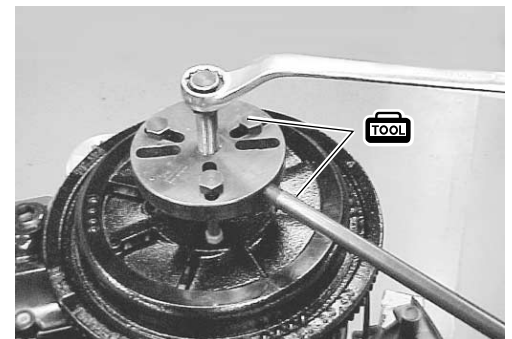

6-6 POWER UNIT

7. Remove battery charge coil ①. (See page 4-5)

8. Remove CKP sensor ②. (See page 3-53)

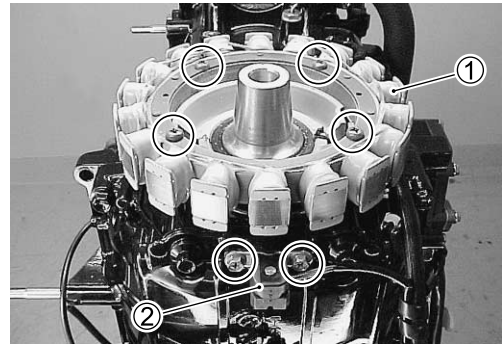

9. Disconnect water return hose ③ from thermostat cover.

10. Remove bolt and water return hose pipe ④.

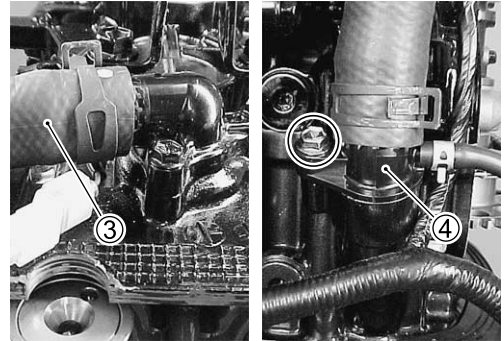

11. Disconnect cylinder temp sensor lead wire connector.

12. Disconnect CMP sensor connector, then remove bolt and CMP sensor ⑤ from cylinder head.

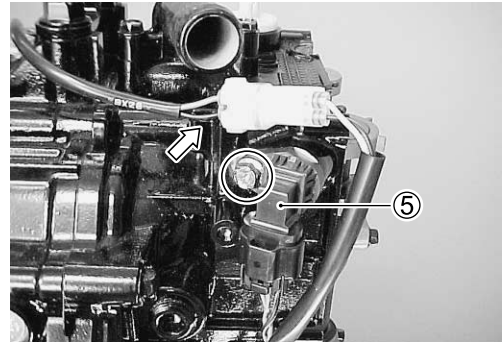

13. Disconnect two ignition coil connectors, then remove four bolts and ignition coil ⑥ and ⑦.

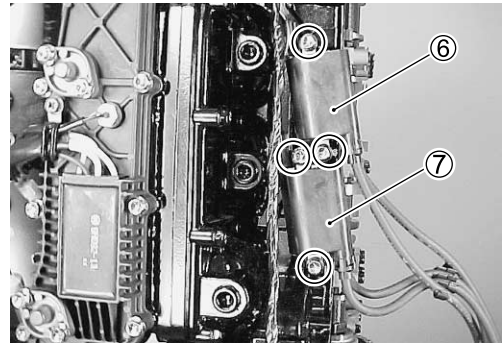

14. Remove oil level dipstick ⑧.

15. Remove bolt and oil level dipstick guide ⑨.

16. Remove nine (9) bolts and Rectifier & regulator ⑩.

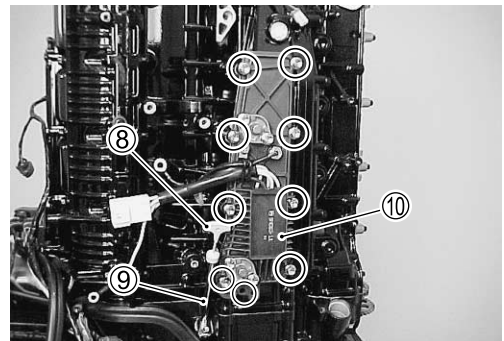

17. Loosen screw ⑪ and disconnect lead wire from oil pressure switch.

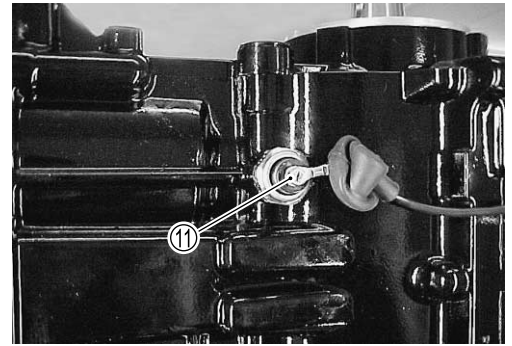

18. Remove two bolts ⑫ and front panel ⑬.

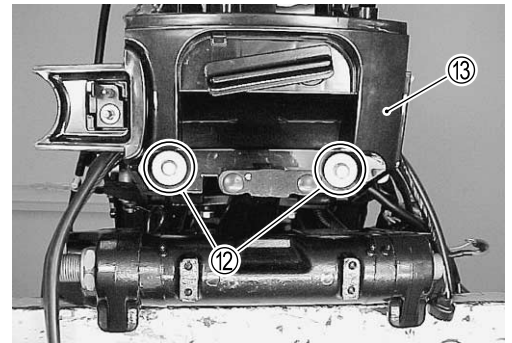

19. Disconnect water inlet hose ⑭ and water outlet hose ⑮ from crankcase.

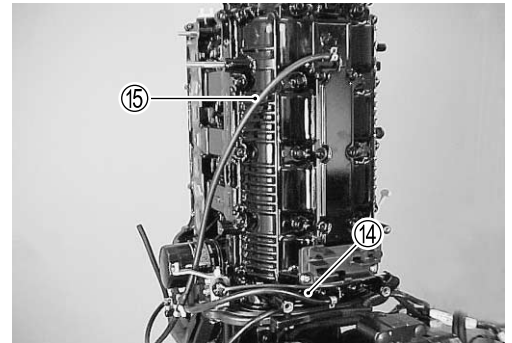

20. Remove cotter pin ⑯ and washer ⑰, then separate clutch lever link ⑱ from clutch shaft arm ⑲.

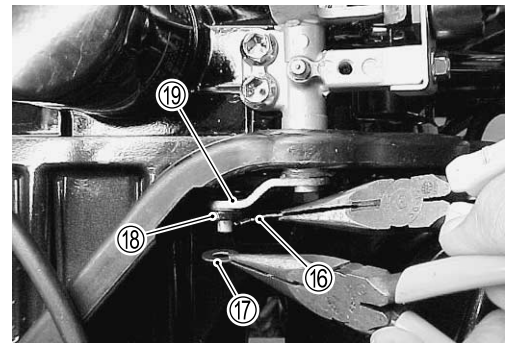

21. Remove E-ring ⑳, clutch control lever ㉑ and clutch shaft arm ⑲.
 22. Remove two bolts ㉒ and clutch lever holder ㉑.
 23. Disconnect neutral switch lead wire connector ㉔.

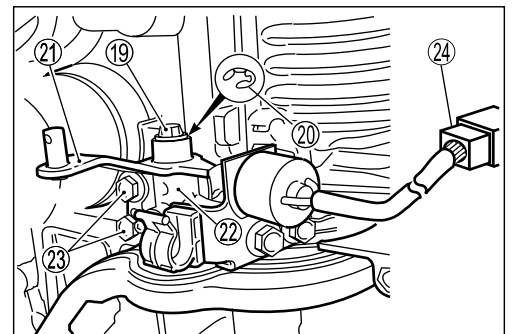

6-8 POWER UNIT

24. Remove pins ②⑤ and side cover seal ②⑥.

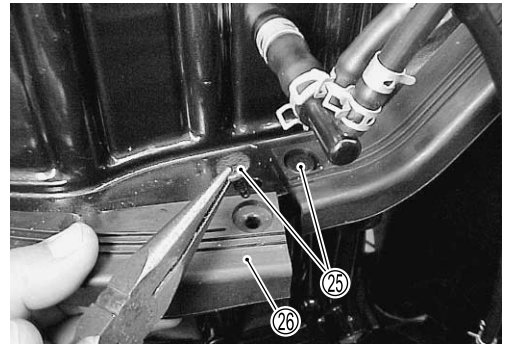

25. Remove sixteen (16) bolts.

26. Lift up and remove power unit from engine holder.

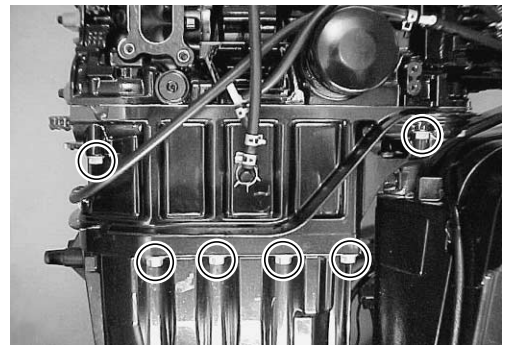
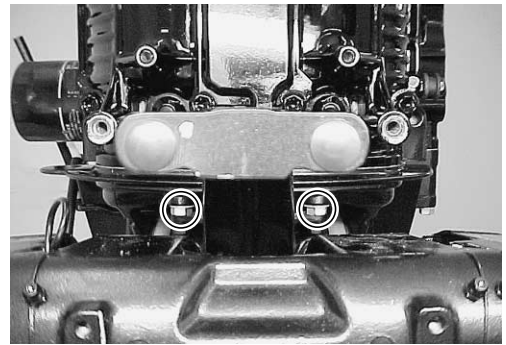
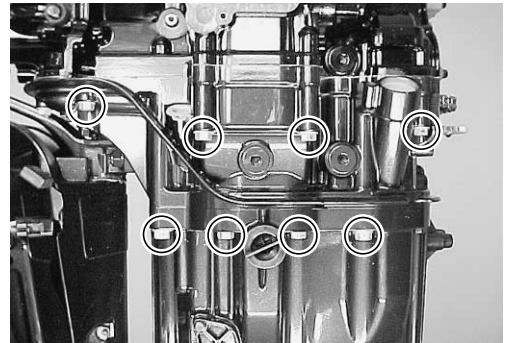

INSTALLATION

Installation is reverse order of removal with special attention to the following steps.

CAUTION

**Do not re-use gasket and O-ring once removed.
Always use new parts.**

POWER UNIT

1. Install dowel pins ① and gasket ②.
2. Apply Suzuki Water Resistant Grease to driveshaft splines.

 **99000-25160 : Suzuki Water Resistant Grease**

NOTE:

Before installing power unit, apply Suzuki Bond to hatched part (2 parts) as shown in figure.

 **99000-31140 : Suzuki Bond 1207B**

3. Lower power unit onto engine holder.

NOTE:

Rotate crankshaft to aid alignment of driveshaft and counter shaft splines.

4. Apply Suzuki Silicone Seal to power unit mounting bolts and tighten bolts to specified torque.

 **99000-31120 : Suzuki Silicone Seal**

 **Power unit mounting bolt :**

8 mm 23 N·m (2.3 kg-m, 16.5 lb.-ft.)
10 mm 50 N·m (5.0 kg-m, 36.0 lb.-ft.)

FLYWHEEL

1. Install battery charge coil. (See page 4-6)
2. Install CKP sensor. (See page 3-53)

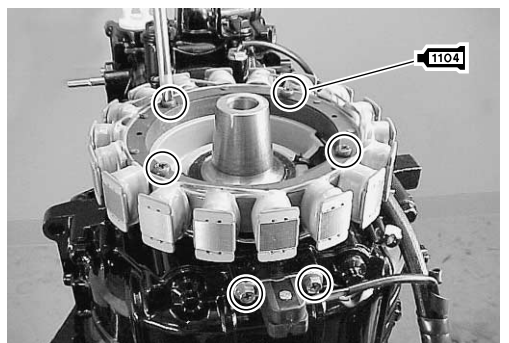
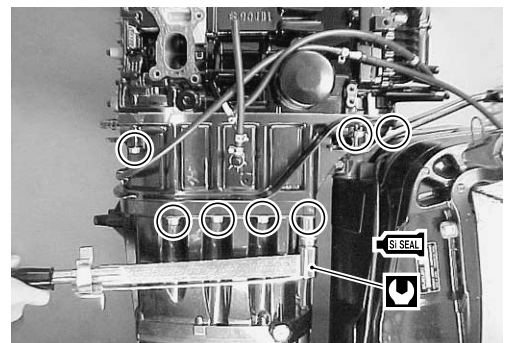
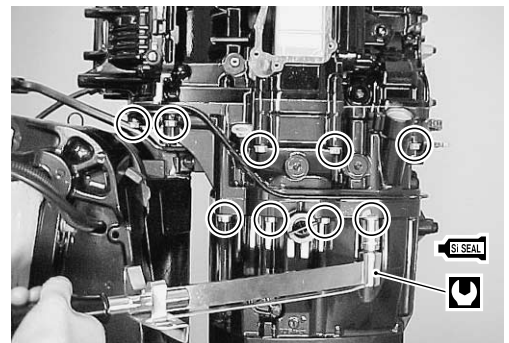
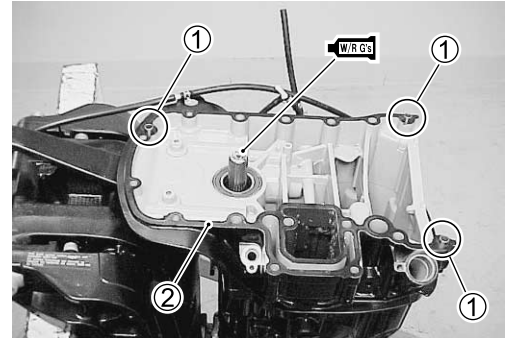
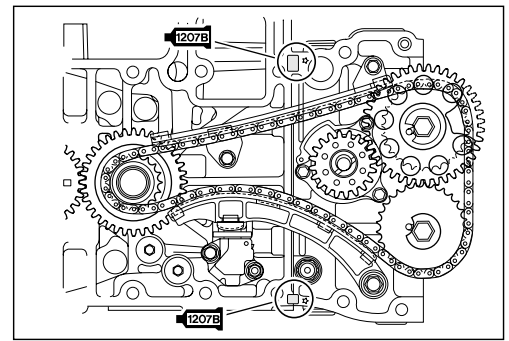

6-10 POWER UNIT

3. Install flywheel and tighten flywheel bolt to specified torque.
(See page 3-52)

 **09930-48720 : Flywheel holder**

 **Flywheel bolt : 245 N·m (24.5 kg-m, 177.0 lb.-ft.)**

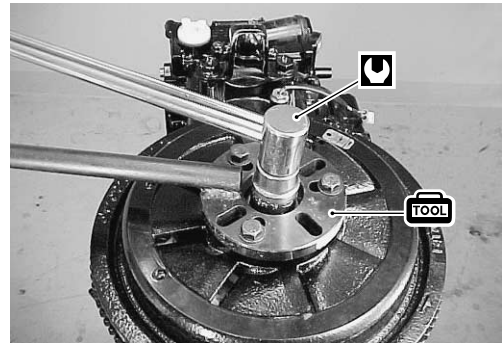

CYLINDER HEAD COVER

NOTE:

*Before installing cylinder head cover, check tappet clearance.
(See page 2-9)*

1. Apply Suzuki Bond to area as shown in figure.

 **99000-31140 : Suzuki Bond No. 1207B**

2. Assemble new O-rings and cylinder head cover gasket to cylinder head cover.

CAUTION

Do not re-use gasket and O-ring once removed. Always use new parts.

NOTE:

Be sure to check all parts for wear or any damage before installation and replace any found defective.

3. Install cylinder head cover to cylinder head and tighten cover bolts to specified torque.

 **Cylinder head cover bolt :**

11 N·m (1.1 kg-m, 8.0 lb.-ft.)

NOTE:

*Use care when installing cylinder head cover.
Be certain cylinder head cover gasket and O-rings remain in their correct position.*

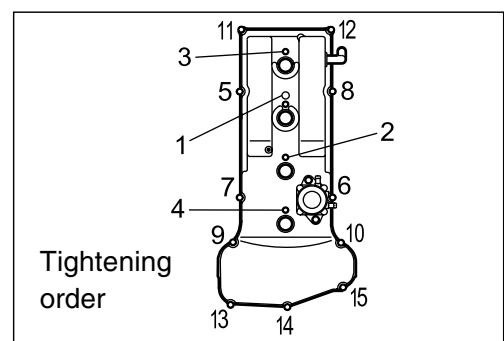
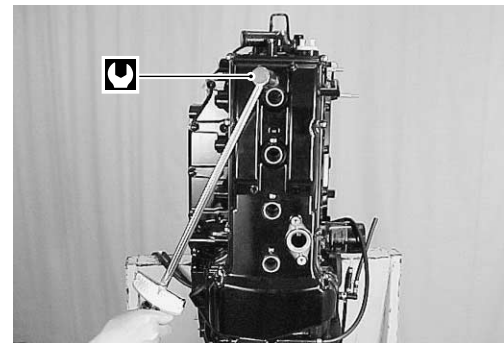
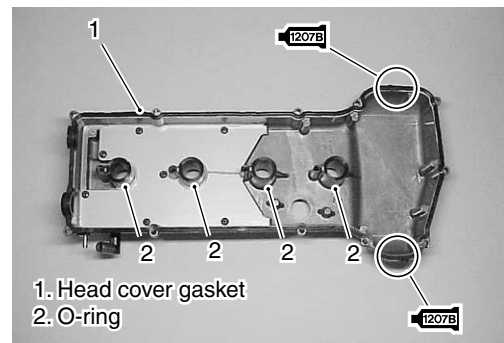

INTAKE MANIFOLD

Install intake manifold assembly. (See page 6-4)

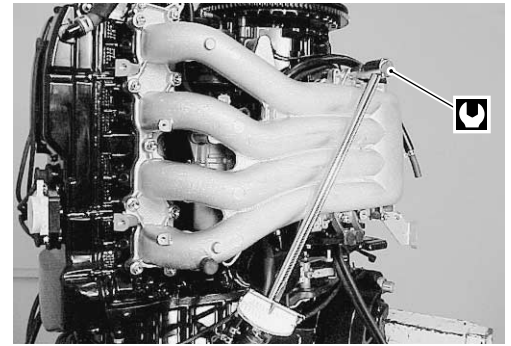
**FUEL INJECTOR**

Install fuel injectors. (See page 5-13)

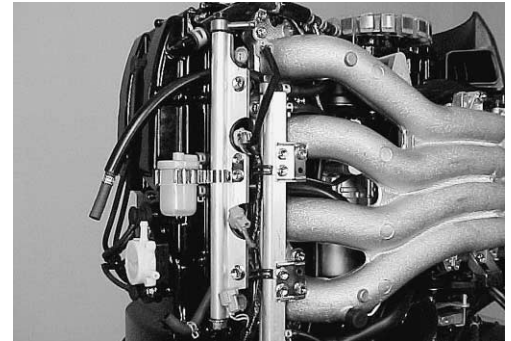
**FINAL ASSEMBLY CHECK**

Perform following checks to ensure proper and safe operation of repaired unit :

- All parts removed have been returned to their original positions.
- Lower unit gear engagement is properly adjusted.
- Fuel and water hose routing match's service manual illustration. (See page 10-8 to 10-11)
- Wire routing match's service manual illustration. (See page 10-2 to 10-7)
- No fuel leakage is evident when fuel system is pressurized. (See page 5-4)
- No water leakage is evident during final test running.

OIL PUMP REMOVAL

1. Remove power unit. (See page 6-5 to 6-8)

NOTE:

Hold camshaft by placing a wrench on hexagon area of camshaft.

2. Remove bolt securing oil pump drive sprocket to camshaft, then remove oil pump drive sprocket.
3. Remove three (3) bolts ① and oil pump assembly ②.

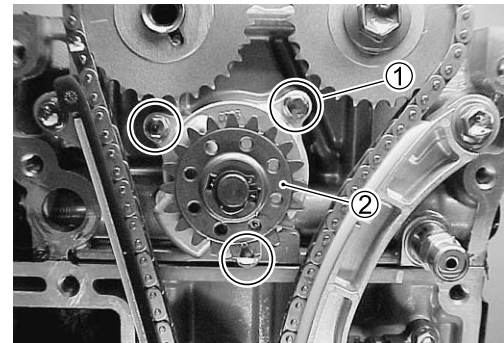
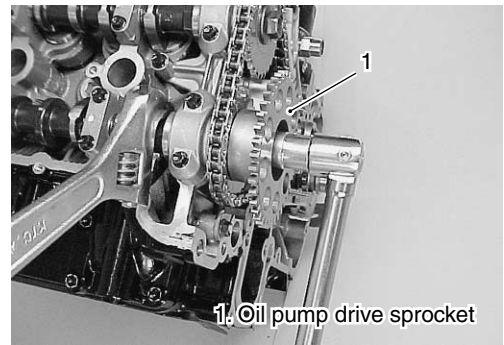

4. Remove circlip ③, driven sprocket ④, pin ⑤ and washer.

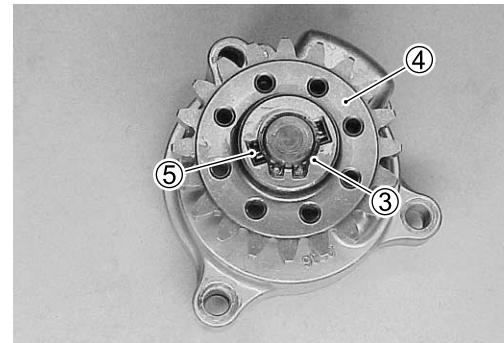

INSPECTION

Oil pump

Inspect outer/inner rotors and oil pump body for wear or other damage.

Replace if necessary.

Seal ring

Inspect of seal ring for nick, cut or wear.

Drive / driven sprocket

Inspect teeth of sprocket for wear or other damage.

Replace if necessary.



INSTALLATION

Installation is reverse order of removal with special attention to the following steps.

- Assemble washer ①, pin ②, driven sprocket ③ and circlip ④ to oil pump shaft.

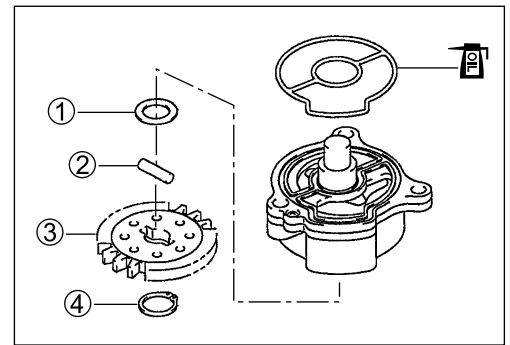

- Apply engine oil to seal ring ⑤, then install seal ring to oil pump body.

CAUTION

Do not re-use seal ring once removed. Always use a new seal ring.

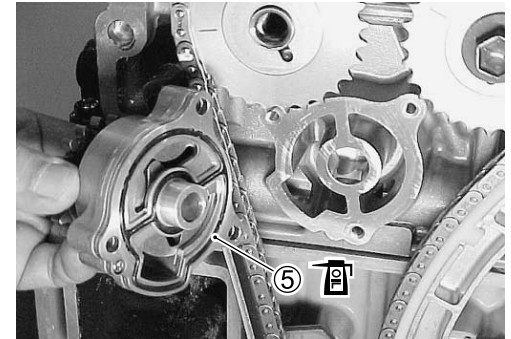

- Install oil pump ⑥ to cylinder head block, then tighten three (3) bolts securely.

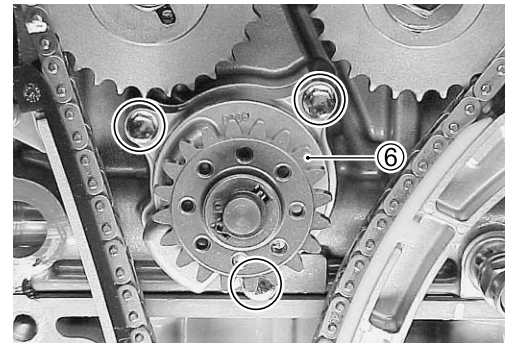

- Install oil pump drive sprocket ⑦ and tighten bolt securely.

-  Oil pump drive sprocket bolt :
78 N·m (7.8 kg-m, 56.5 lb.-ft.)

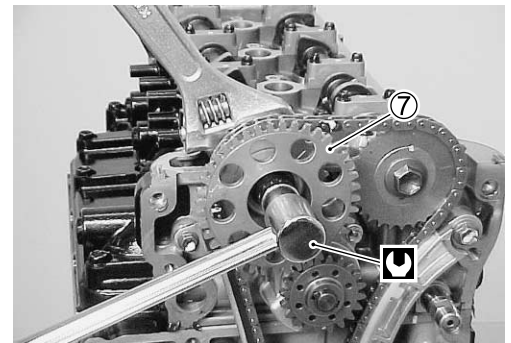

TIMING CHAIN / TENSIONER

REMOVAL

Prior to this service work :

- Remove power unit. (See page 6-5 to 6-8)

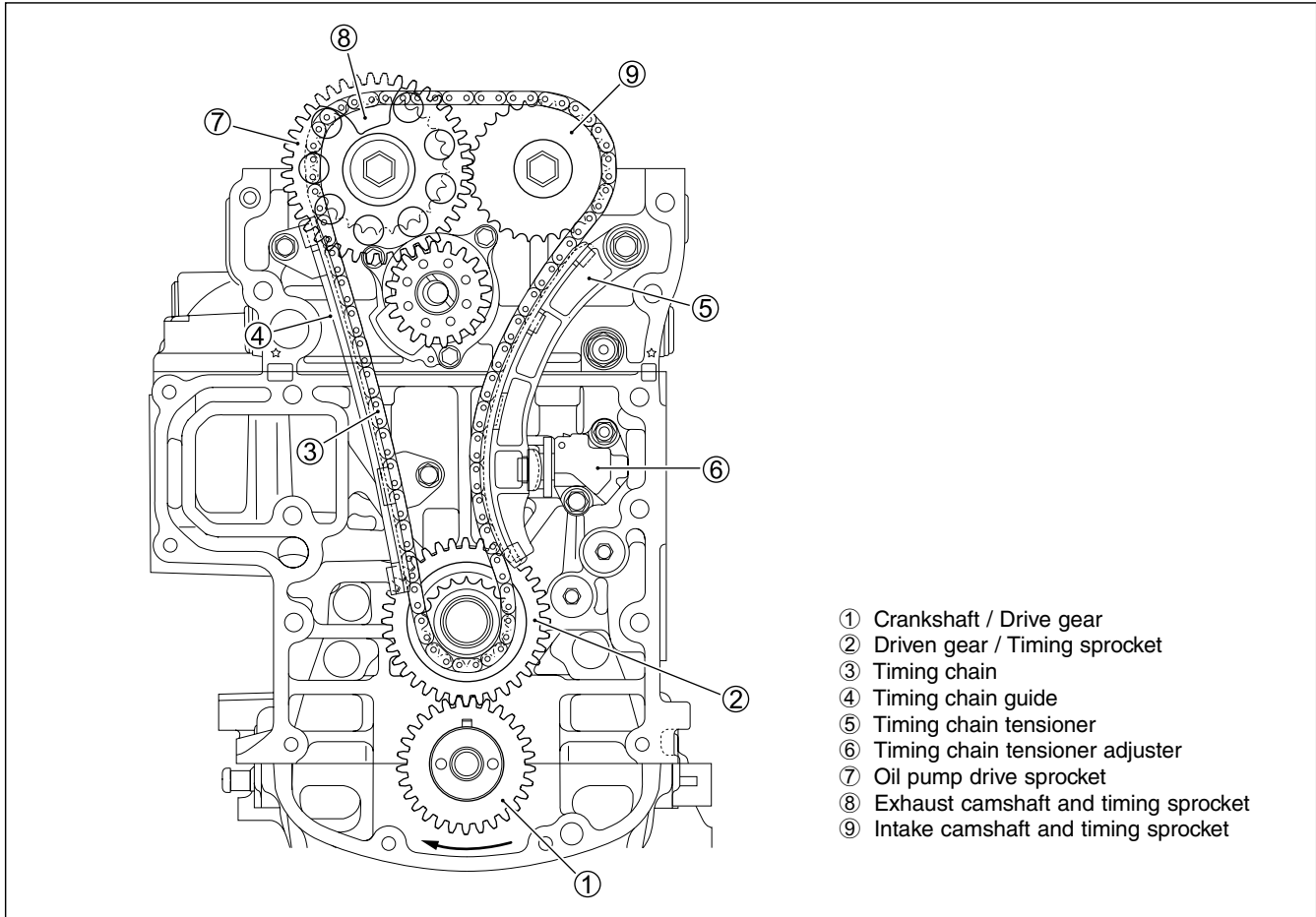

- ① Crankshaft / Drive gear
- ② Driven gear / Timing sprocket
- ③ Timing chain
- ④ Timing chain guide
- ⑤ Timing chain tensioner
- ⑥ Timing chain tensioner adjuster
- ⑦ Oil pump drive sprocket
- ⑧ Exhaust camshaft and timing sprocket
- ⑨ Intake camshaft and timing sprocket

1. Turn crankshaft in its normal running direction (Ⓜ direction) until No.1 cylinder reaches top dead center.

NOTE :

To bring No.1 cylinder top dead center, turn crankshaft to locate match mark (key) @ position at the top as shown in figure.

CAUTION

When timing chain has been removed, never turn crankshaft or camshaft.

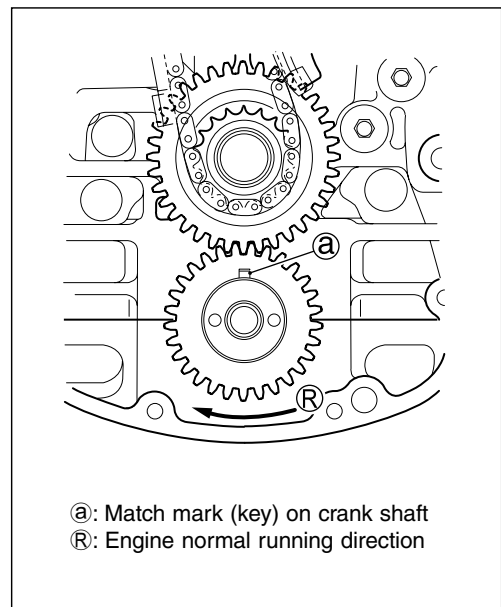

- @: Match mark (key) on crank shaft
- Ⓜ: Engine normal running direction

 09911-49910 : Crankshaft holder

2. Remove bolt ① and oil pump drive sprocket ②.
(See page 6-12)

NOTE:

Hold camshaft by placing a wrench on the hexagon area of camshaft.

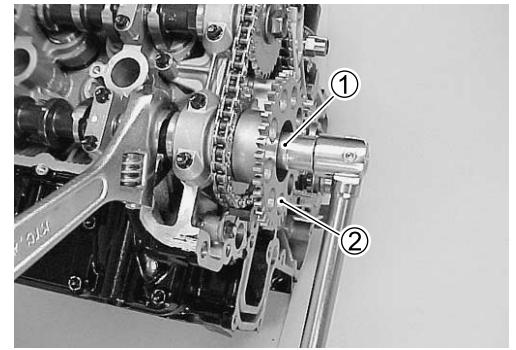

3. Remove bolts ③ and timing chain guide ④.

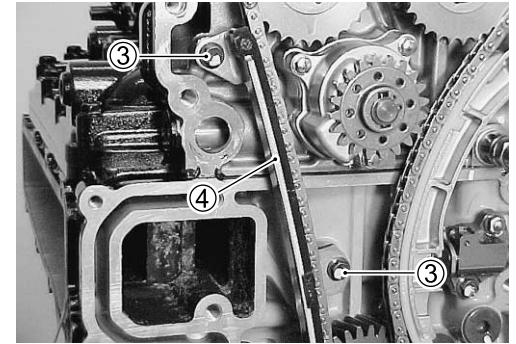

4. Remove bolt, nut and chain tensioner adjuster ⑤.

5. Remove bolt ⑥ and chain tensioner ⑦.

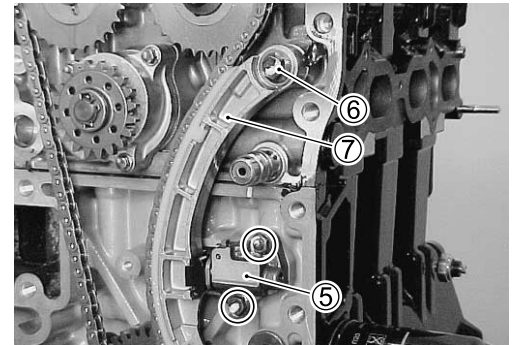

6. Remove timing chain ⑧, exhaust camshaft timing sprocket ⑨ and dowel pin ⑩.

7. Remove bolt ⑪ and intake camshaft timing sprocket ⑫.

NOTE:

Hold camshaft by placing a wrench on the hexagon area of camshaft.

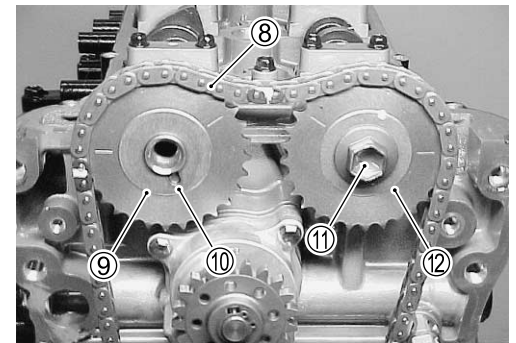

8. Remove driven gear ⑬.

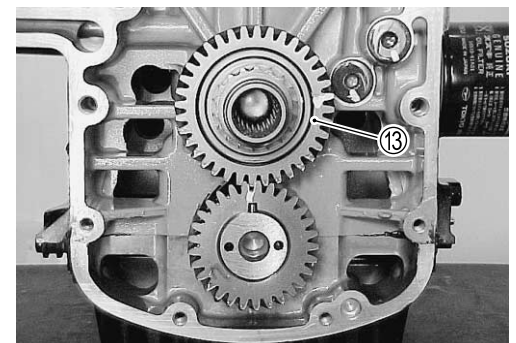

INSPECTION

NOTE:

If cracks, excessive wear, defective or other damage is found on any component, replaced component.

Timing chain

Inspect timing chain for wear or other damage.
Replace if necessary.

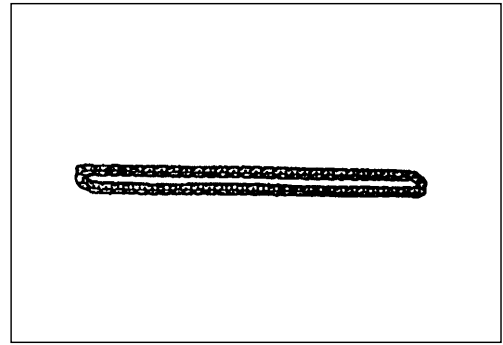

Tensioner adjuster

Inspect tensioner adjuster for smooth operation.
Inspect oil passage for clog.
Replace or clean if necessary.

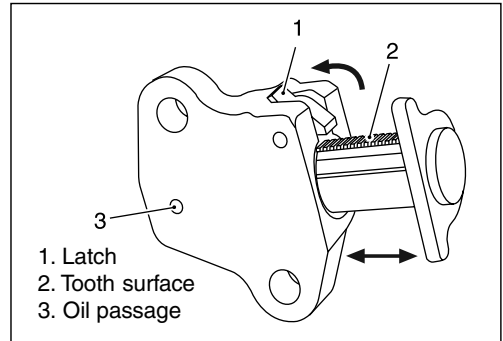

Timing chain tensioner / chain guide

Inspect oil shoe for wear or other damage.
Replace if necessary.

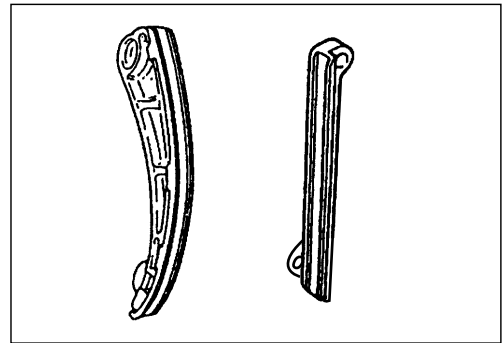

Timing chain sprocket

Inspect teeth of sprocket for wear or other damage.
Replace if necessary.



Drive / driven gear and bearing

Inspect drive gear and driven gear for wear or other damage.
Replace if necessary.

Inspect driven gear bearing for pitting, rough or other damage.
Replace if necessary.

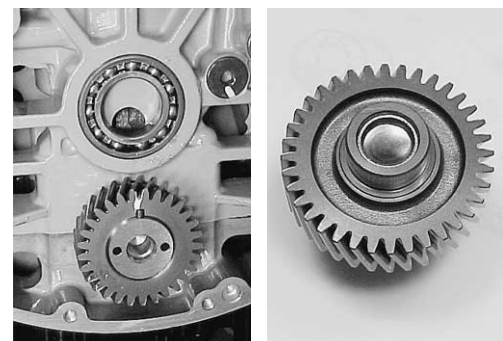

INSTALLATION

Installation is reverse order of removal with special attention to the following steps.

1. Check that match mark (key way) **a** on crankshaft drive gear points to 12 o'clock (towards cylinder head).
(Check that #1 cylinder is at top dead center.)
2. Install driven gear **1** on cylinder block so that match mark (key way) **a** aligns with match mark (•) **b** on driven gear as shown in figure.
3. Install dowel pin **2** and sprocket **3** on exhaust camshaft.
Install dowel pin **4** and sprocket **5** on intake camshaft,
then tighten bolt **6** securely.

 **Timing sprocket bolt : 78 N·m (7.8 kg·m, 56.5 lb.-ft.)**

NOTE:

When installing camshaft sprocket, position side of sprocket with two engraved lines **c**, **d**, **e** and **f** facing down toward engine holder as shown in figure.

4. Check that engraved lines **c** and **f** on sprockets are opposite each other and aligned with mating face **x** of cylinder head cover when match marks (dot) **g** and **h** on sprockets are located as shown in figure.

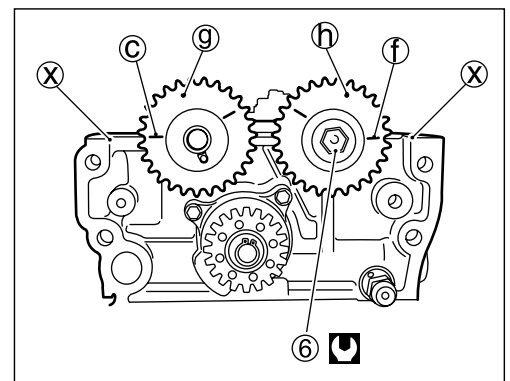
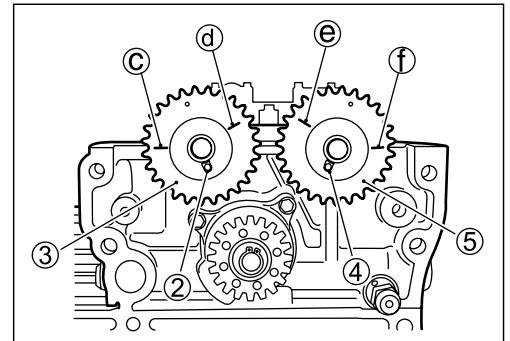
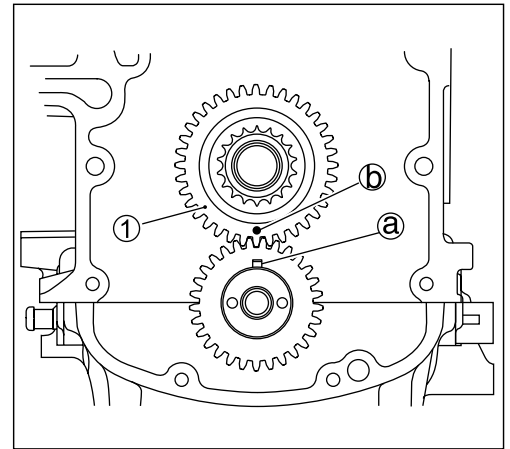

6-18 POWER UNIT

- As shown in figure, position timing chain on driven gear sprocket with GOLD plate of chain aligned with match mark (•) ⑥ on driven gear.
- As shown in figure, engage timing chain with exhaust sprocket with one BLUE plate of chain aligned with match mark (dot) ⑨ of exhaust sprocket.
- As shown in figure, engage timing chain with intake sprocket with another BLUE plate of chain aligned with match mark (dot) ⑩ of intake sprocket.

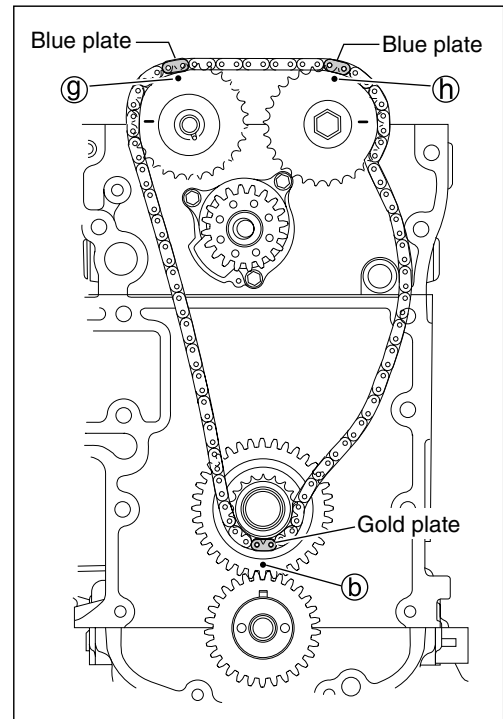

- Install timing chain guide ⑦, then tighten bolts securely.

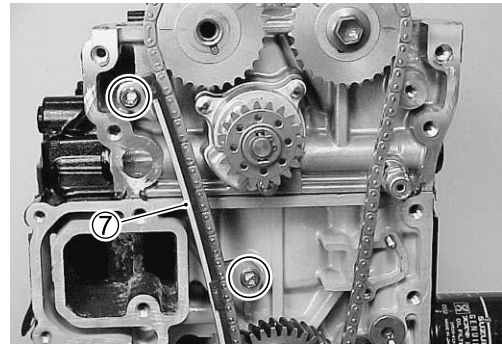

- Insert spacer ⑧ into chain tensioner. Install chain tensioner ⑨ as shown in figure. Apply oil to chain tensioner.

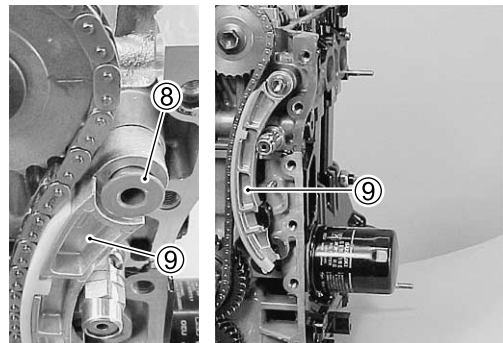

- With latch of tensioner adjuster pushed in and plunger pushed back into body, insert stopper into latch and body. After inserting stopper, check to make sure that plunger will not come out.

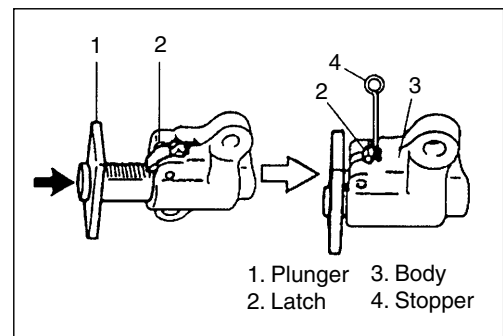

11. Install timing chain tensioner adjuster ⑩.
Tighten bolt and nut, pre-coated with thread lock, to specified torque.

 99000-32050 : Thread lock "1342"

 Tensioner adjuster bolt / nut :
11 N·m (1.1 kg·m, 8.0 lb.-ft.)

12. Apply engine oil to timing chain.

13. Remove stopper from tensioner adjuster to release plunger.

14. Turn crankshaft in normal running direction two complete turns and check that crankshaft match mark (key way) ① points toward the top and at the same time, engraved lines ③ and ④ on sprockets aligns with cylinder head cover mating face ②.

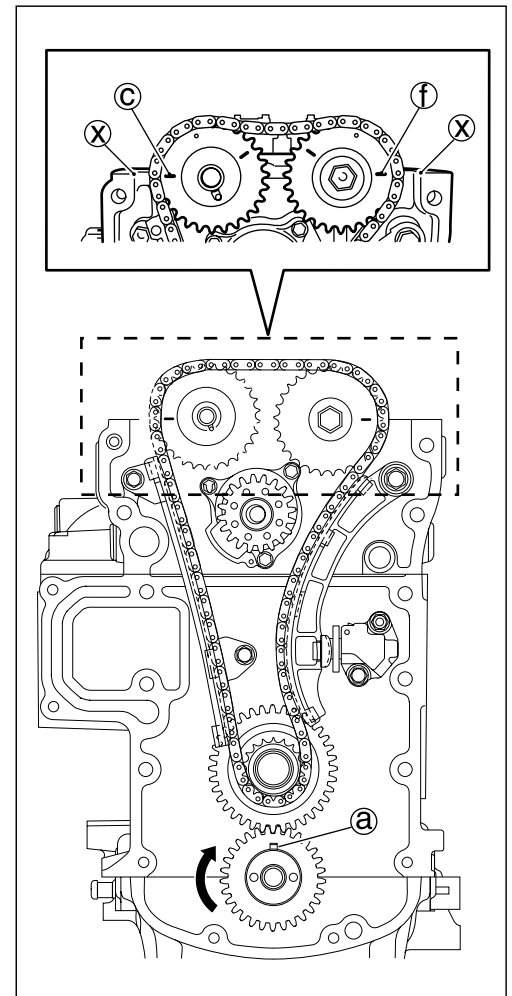
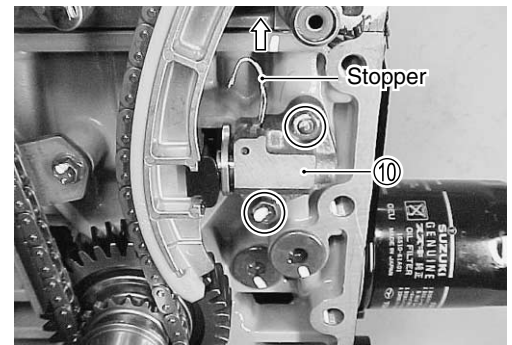

15. Install oil pump drive sprocket ⑪ and tighten bolt securely.

 Oil pump drive sprocket bolt :
78 N·m (7.8 kg·m, 56.5 lb.-ft.)

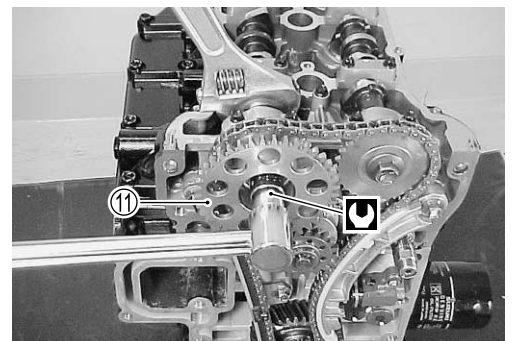

CYLINDER HEAD ASSEMBLY

(Cylinder head / valve / camshaft)

REMOVAL

Prior to removing cylinder head :

- Remove power unit. (See page 6-5 to 6-8)
- Remove timing chain. (See page 6-14 to 6-15)

1. Remove bolts ① and oil pump ②.
2. Remove oil relief valve ③ and gasket ④.
3. Remove bolts securing camshaft housing ⑤ to cylinder head, then remove each camshaft housing.

NOTE:

For ease of assembly, note position of each individual camshaft housing.

4. Remove intake and exhaust camshafts.

5. Loosen eighteen (18) cylinder head bolts according to numerical order in figure and remove them.
6. Remove cylinder head assembly and head gasket.

NOTE:

Use special tool (10 mm deep socket wrench) when loosening cylinder head bolts.

 09919-16010 : Deep socket wrench (10 mm)

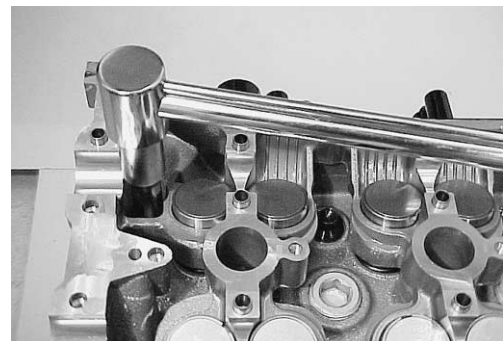
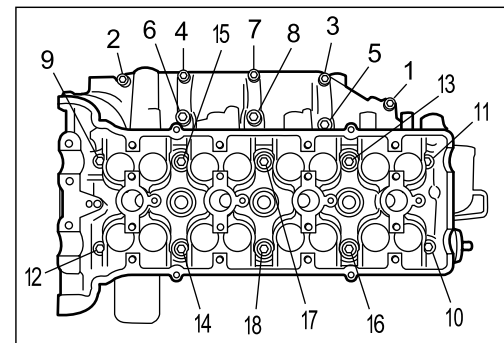
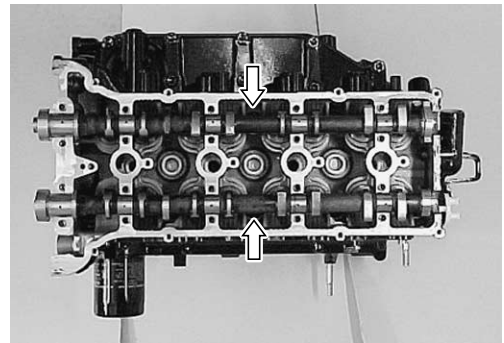
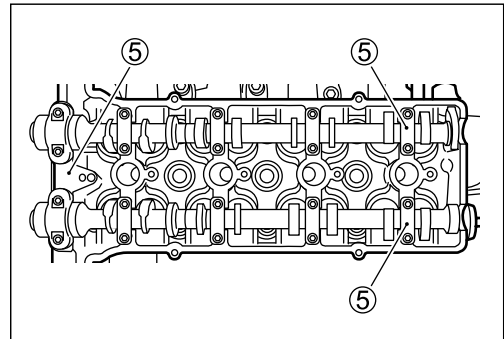
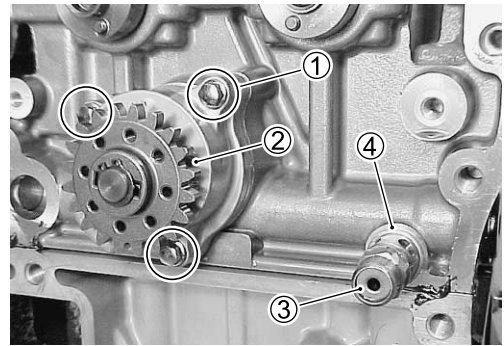

INSTALLATION

Installation is in reverse order of removal with special attention to the following steps.

CAUTION

Do not re-use gasket once removed. Always use a new gasket.

1. Insert dowel pins and place cylinder head gasket into position on cylinder.
2. Position cylinder head on cylinder.
3. Apply engine oil lightly to cylinder head bolts and tighten them gradually as follows.
 - (a) Tighten all bolts to 50 percent (%) of specified torque according to numerical order in figure.

Cylinder head bolt :

1 st step 10 mm 35 N·m (3.5 kg-m, 25.5 lb.-ft.)
8 mm 12 N·m (1.2 kg-m, 8.5 lb.-ft.)

- (b) Loosen all bolts to 0 N·m (0 kg-m, 0 lb.-ft.) according to reverse order in figure.
- (c) Again tighten all bolts to 50 percent (%) of specified torque according to numerical order in figure.

Cylinder head bolt :

3 rd step 10 mm 35 N·m (3.5 kg-m, 25.5 lb.-ft.)
8 mm 12 N·m (1.2 kg-m, 8.5 lb.-ft.)

- (d) Finally tighten all bolts to specified torque according to numerical order in figure.

Cylinder head bolt :

Final step 10 mm 70 N·m (7.0 kg-m, 50.5 lb.-ft.)
8 mm 23 N·m (2.3 kg-m, 16.5 lb.-ft.)

NOTE:

Use special tool (10 mm deep socket wrench) when tightening cylinder head bolts.

 **09919-16010 : Deep socket wrench (10 mm)**

4. Apply engine oil around tappets and install them.
5. Install tappet shims.
6. Apply engine oil to surface of each camshaft lobe and journal, then install them.

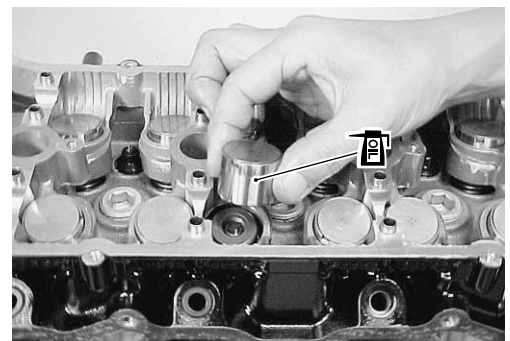
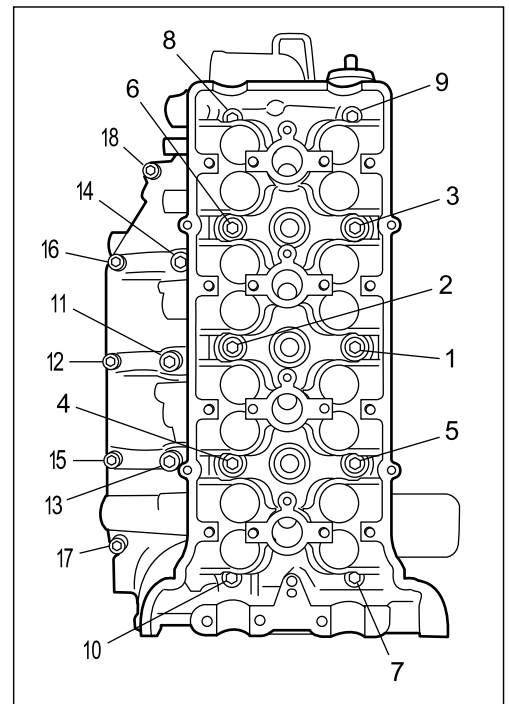
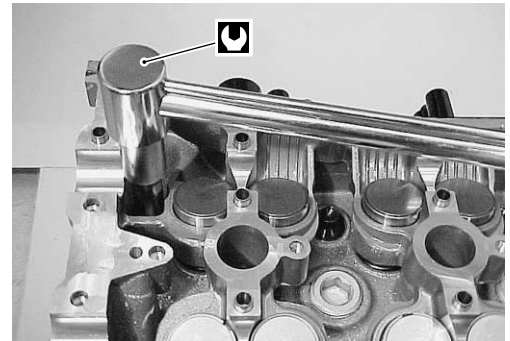
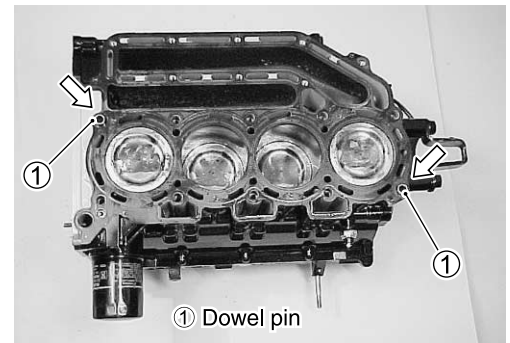

NOTE:

Before installing camshafts, turn crankshaft until No.1 cylinder reaches top dead center. (See page 6-14)

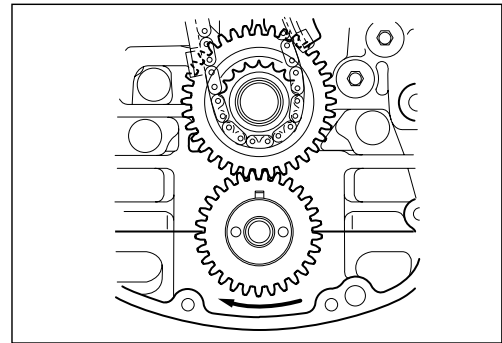

NOTE:

When install camshaft, adjust relative position between sprockets and chain so that match marks (dot) on timing sprockets are as shown in figure and engraved lines on sprockets align with cylinder head cover mating face.

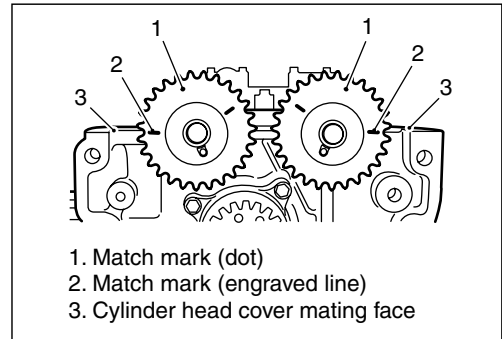

7. Install camshaft housing pins as shown in figure.

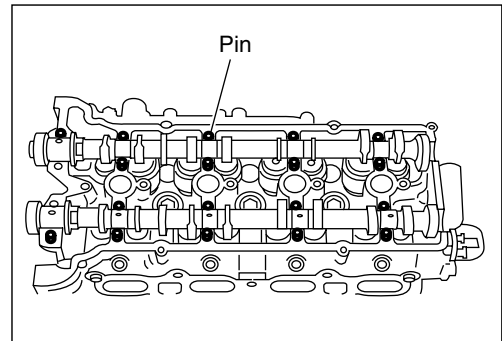

8. Check position of camshaft housing.

NOTE:

Embossed marks are provided on each camshaft housing indicating position and direction of installation.

9. Install housings as indicated by these marks.

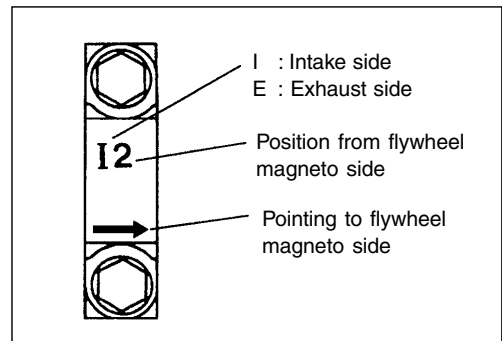

10. Apply engine oil lightly to housing bolts.

11. Lightly seat all housing bolts at first.

According to numerical order in figure, tighten bolts to 1/3 of specified torque, then 2/3 of specified torque and finally to full specified torque.

 **Camshaft housing bolt : 11 N·m (1.1 kg-m, 8.0 lb.-ft.)**

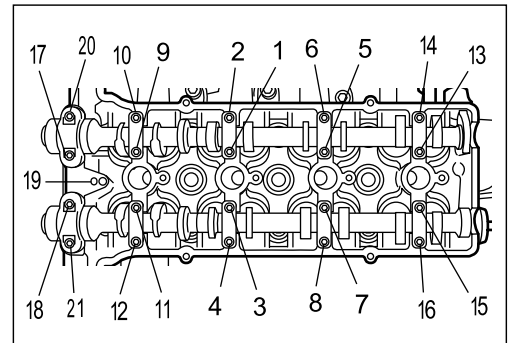

12. Install gasket ① and oil relief valve ②, then tighten valve securely.

 **Oil relief valve : 27 N·m (2.7 kg-m, 19.5 lb.-ft.)**

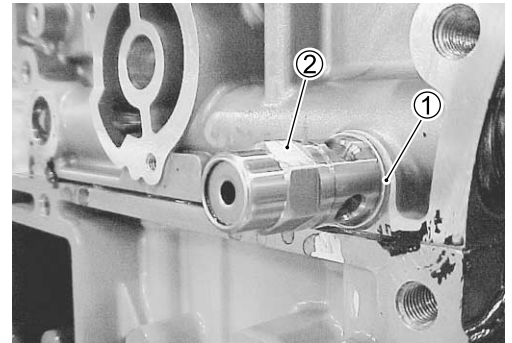

13. Install timing chain. (See page 6-17)

14. Install oil pump assembly. (See page 6-13)

15. Adjust tappet clearance. (See page 2-9)

DISASSEMBLY

1. Remove tappets with shims.

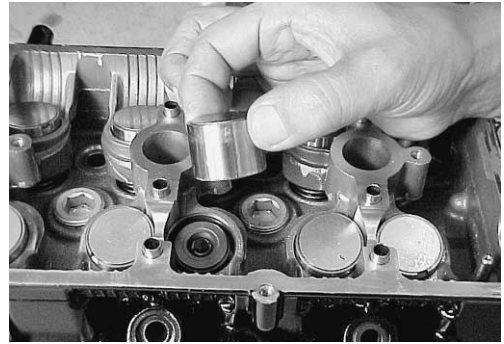

2. Using valve lifter and attachment, remove valve cotters ① while compressing valve spring.

-  **09916-19030 : Valve lifter**
- 09916-14910 : Attachment**
- 09916-84511 : Tweezers**

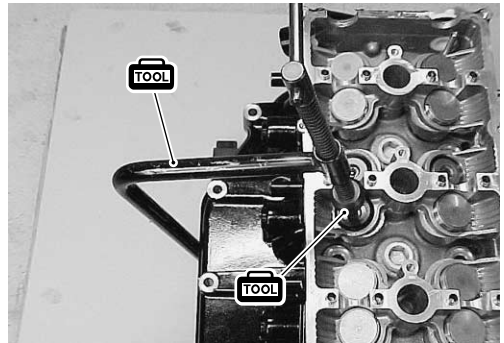

3. Remove valve spring retainer ②, valve spring ③ and valve ④.

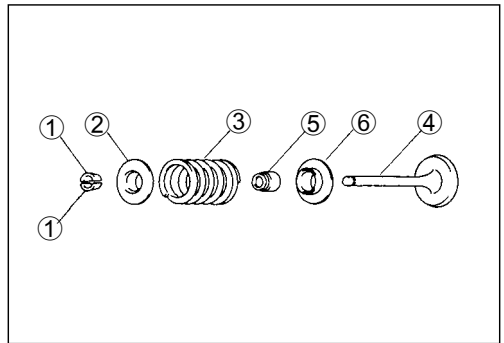
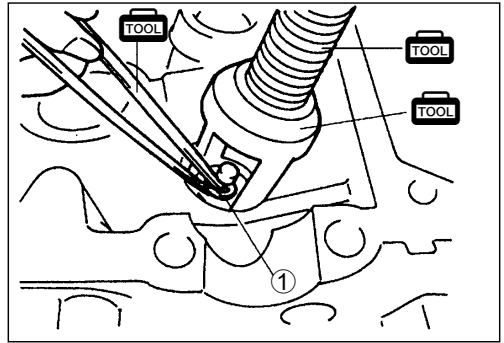

4. Remove valve stem seal ⑤ and valve spring seat ⑥.

NOTE:

Reassemble each valve and valve spring in their original positions.

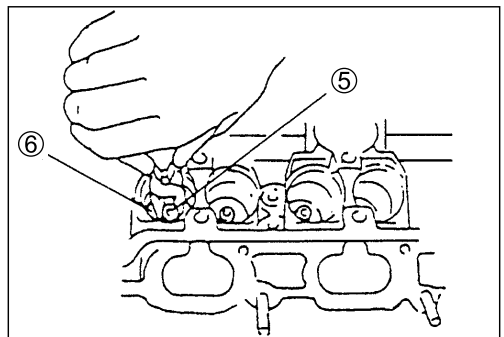

INSPECTION / SERVICING

NOTE:

If cracks, excessive wear or other damage is found on any component, replace component.

CYLINDER HEAD

Remove all carbon from combustion chambers.

NOTE:

- Do not use any sharp edged tool to scrape carbon off cylinder head or its components.
- Be careful not to scuff or nick metal surfaces when decarboning.

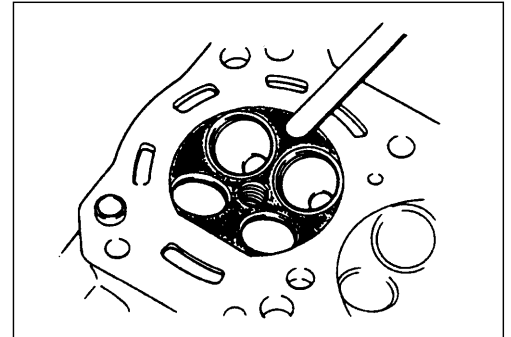

Inspect cylinder head for crack in intake and exhaust ports, combustion chambers and head surface.

Valve seat

Inspect valve seat for crack or other damage.
Replace if necessary.

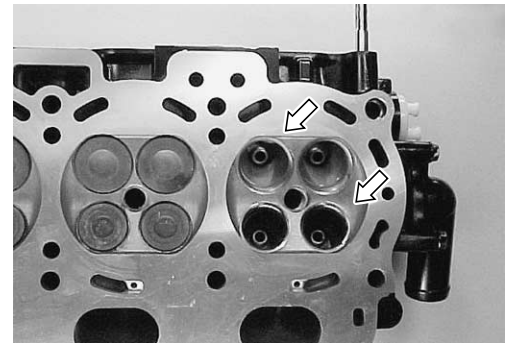

Cylinder head distortion

Using a straightedge and thickness gauge, measure cylinder head distortion (gasket surface) at a total of six (6) locations as shown in figure.

 **09900-20803 : Thickness gauge**

Cylinder head distortion :
Service limit : 0.05 mm (0.002 in.)

If measurement exceeds service limit, resurface or replace cylinder head.

NOTE:

Cylinder head can be resurfaced, using a surface plate and #400 grit wet sandpaper.
Move cylinder head in a figure eight pattern when sanding.

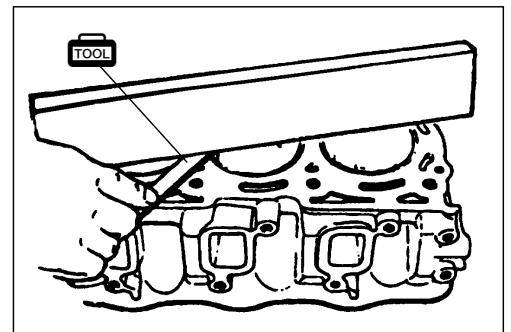
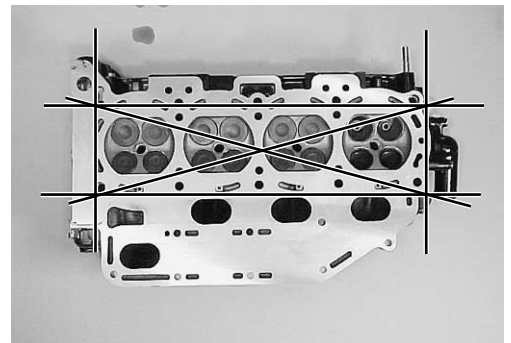

Manifold seating faces distortion

Using a straightedge and thickness gauge, measure cylinder head distortion to intake manifold seating faces.

Manifold seating faces distortion:
Service limit : 0.10 mm (0.004 in.)

If measurement exceeds service limit, resurface or replace cylinder head.

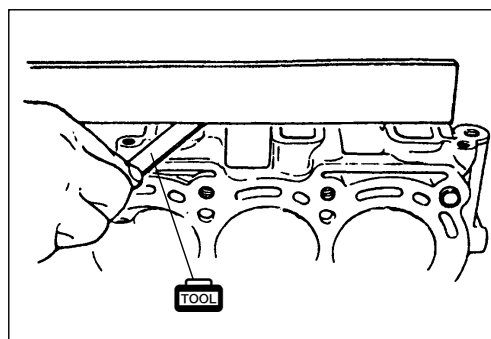

Water jackets

Inspect water jackets for clog or obstruction.
 Clean water jackets if necessary.

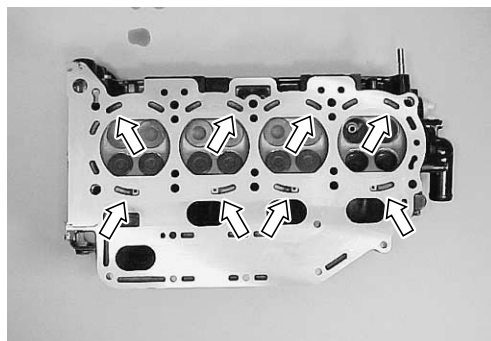

CAMSHAFT

Cam face

Inspect cam face for scratches and wear.

Cam wear

Measure cam height (H).

 **09900-20202 : Micrometer**

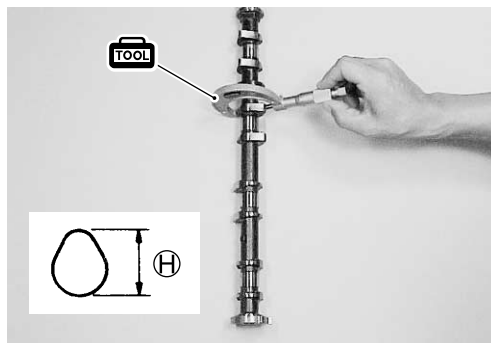

Cam height (H) :

Standard :

- DF90 IN 37.320 – 37.480 mm (1.4693 – 1.4765 in.)**
- EX 37.030 – 37.190 mm (1.4579 – 1.4642 in.)**
- DF115 IN 39.220 – 39.380 mm (1.5441 – 1.5504 in.)**
- EX 39.040 – 39.200 mm (1.5370 – 1.5433 in.)**

Service limit :

- DF90 IN 37.220 mm (1.4654 in.)**
- EX 36.930 mm (1.4539 in.)**
- DF115 IN 39.120 mm (1.5402 in.)**
- EX 38.940 mm (1.5330 in.)**

If measurement exceeds service limit, replace camshaft.

Camshaft identification

DF90 and DF115 camshafts differ as shown below.

Model	Identification mark
DF90	Dent
DF115	No dent

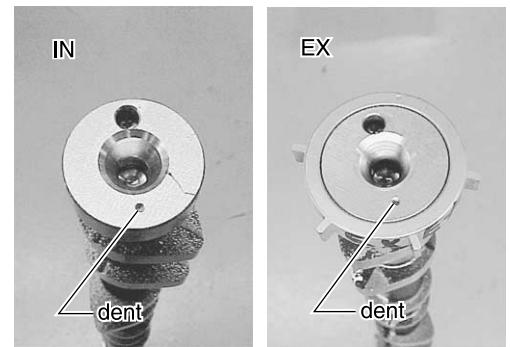
**Camshaft runout**

Using a set of V-blocks, support the camshaft on a surface plate. Measure runout using dial gauge.

TOOL 09900-20602 : Dial gauge
09900-20701 : Magnetic stand

Camshaft runout :
Service limit : 0.10 mm (0.004 in.)

If measurement exceeds service limit, replace camshaft.

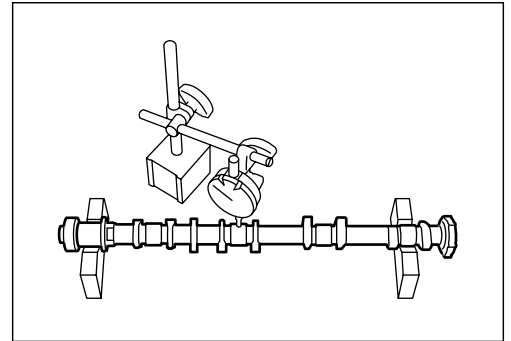
**CAMSHAFT JOURNAL**

Inspect camshaft journals and camshaft housing for pitting, scratches, wear or other damage.

Replace camshaft or cylinder head with housing if necessary.

NOTE:

Camshaft housing and cylinder head should be replaced as a set.

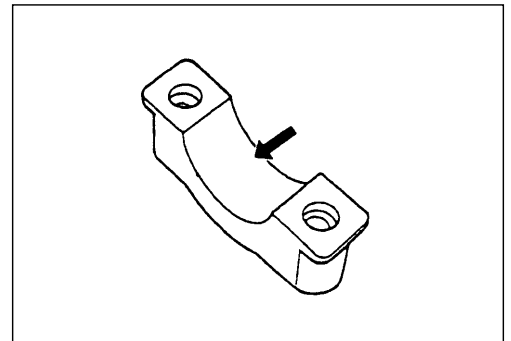

Camshaft journal oil clearance

Measure journal oil clearance using Plastigauge as follows.

1. Clean housing and camshaft journals.
2. Install camshaft to cylinder head.
3. Place Plastigauge across full width of camshaft journal (parallel to camshaft).

-  **09900-22302 : Plastigauge (0.051 — 0.125 mm)**
- 09900-22301 : Plastigauge (0.025 — 0.076 mm)**

4. Install camshaft housing. According to numerical order in figure, tighten housing bolts in 3 steps. (1/3 of specification, 2/3 of specification, full torque specification)

 **Camshaft housing bolt : 11 N·m (1.1 kg·m, 8.0 lb.-ft.)**

NOTE:

Do not rotate camshaft while Plastigauge is installed.

5. Remove camshaft housing.
6. Using scale on Plastigauge envelope, measure Plastigauge at its widest point.

Camshaft journal oil clearance :

- Standard : Top, 2nd, 3rd, 4th journal**
0.020 – 0.062 mm (0.0008 – 0.0024 in.)
- 5th journal**
0.045 – 0.087 mm (0.0018 – 0.0034 in.)
- Service limit : 0.12 mm (0.0047 in.)**

NOTE:

The location No.s of journal are in order from flywheel magneto to the bottom of cylinder.

If journal oil clearance exceeds service limit, measure camshaft journal (outside dia.) and camshaft housing (inner dia.). Based on measurements, replace camshaft and/or cylinder head with camshaft housing.

 **09900-20205 : Micrometer**

Camshaft journal outside diameter :

- Standard : Top, 2nd, 3rd, 4th journal**
22.959 – 22.980 mm (0.9039 – 0.9047 in.)
- 5th journal**
25.934 – 25.955 mm (1.0210 – 1.0219 in.)
- Service limit : Top, 2nd, 3rd, 4th journal**
22.869 mm (0.9004 in.)
- 5th journal**
25.844 mm (1.0175 in.)

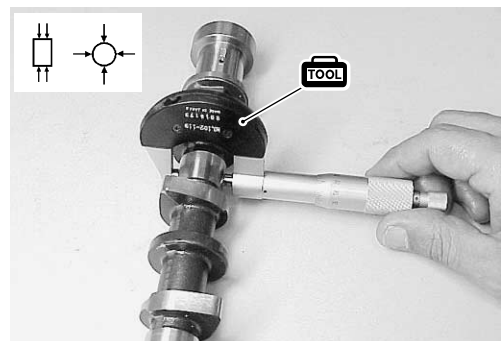
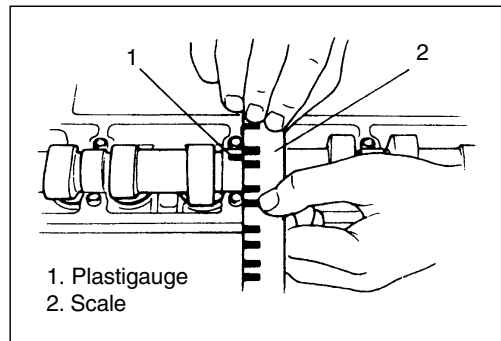
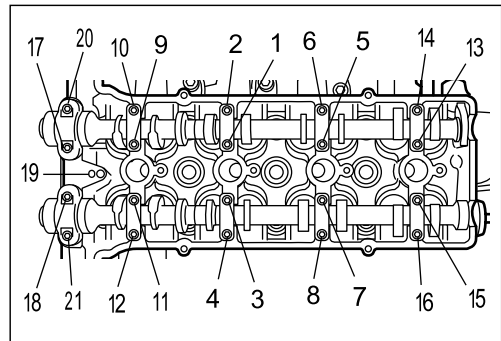
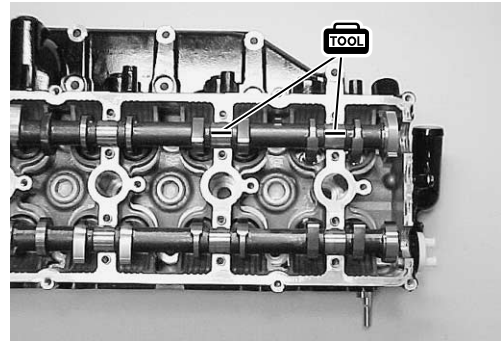

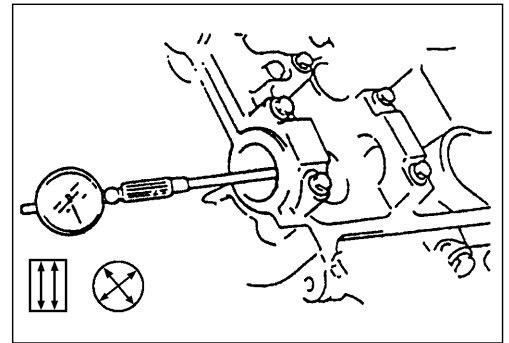
Camshaft journal (housing) inside diameter :**Standard : Top, 2nd, 3rd, 4th journal****23.000 – 23.021 mm (0.9055 – 0.9063 in.)****5th journal****26.000 – 26.021 mm (1.0236 – 1.0244 in.)****Service limit : Top, 2nd, 3rd, 4th journal****23.171 mm (0.9122 in.)****5th journal****26.171 mm (1.0304 in.)****TAPPET / TAPPET SHIM****Wear of tappet and shim**

Inspect tappet and shim for pitting, scratches, or other damage.
Replace if necessary.

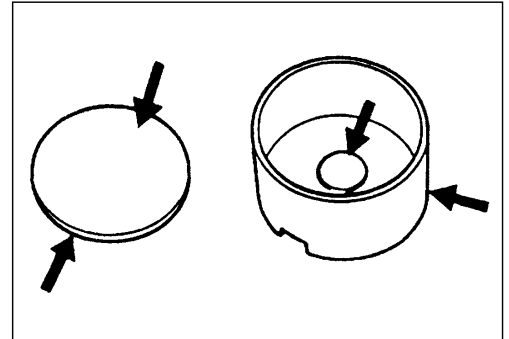

Measure cylinder head bore and tappet outside diameter to determine cylinder head to tappet clearance.

 **09900-20202 : Micrometer**

If measurement exceeds service limit, replace tappet or cylinder head.

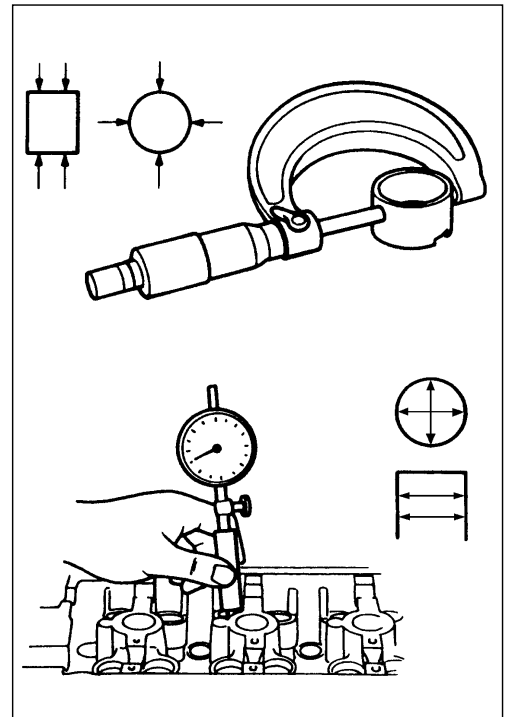
Cylinder head bore to tappet clearance :**Standard : 0.025 – 0.066 mm (0.0010 – 0.0026 in.)****Service limit : 0.150 mm (0.0059 in.)****Tappet outer diameter :****Standard : 30.959 – 30.975 mm (1.2189 – 1.2195 in.)****Cylinder head bore :****Standard : 31.000 – 31.025 mm (1.2203 – 1.2215 in.)**

VALVE / VALVE GUIDE**Valve guide to valve stem clearance**

Using a micrometer and bore gauge, take diameter readings on valve stems and guides to check guide to stem clearance. Be sure to take readings at more than one place along length of each stem and guide.

 **09900-20205 : Micrometer**

Valve stem outside diameter

Using micrometer, measure valve stem outside diameter.

Valve stem outside diameter :**Standard:**

IN 5.965 – 5.980 mm (0.2348 – 0.2354 in.)

EX 5.940 – 5.955 mm (0.2339 – 0.2344 in.)

Valve guide inside diameter

Using a small bore gauge, measure valve guide inside diameter.

Valve guide inside diameter :**Standard :**

IN 6.000 – 6.012 mm (0.2362 – 0.2367 in.)

EX 6.000 – 6.012 mm (0.2362 – 0.2367 in.)

Valve guide to valve stem clearance**Valve guide to valve stem clearance :****Standard :**

IN 0.020 – 0.047 mm (0.0008 – 0.0019 in.)

EX 0.045 – 0.072 mm (0.0018 – 0.0028 in.)

Service limit :

IN 0.070 mm (0.0028 in.)

EX 0.090 mm (0.0035 in.)

If measurement exceeds service limit, replace valve and/or valve guide.

NOTE:

For valve guide replacement, see "VALVE GUIDE REPLACEMENT" section on page 6-35.

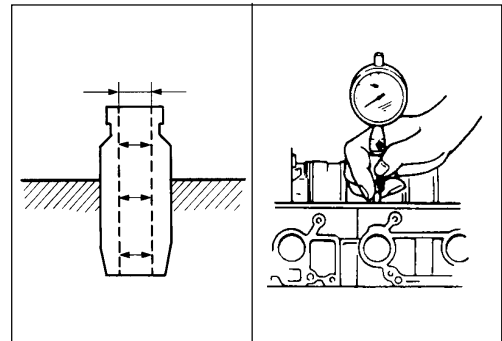
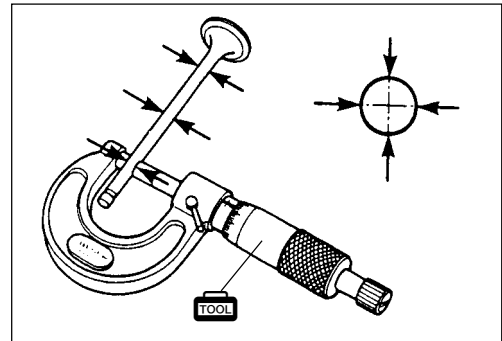

Valve stem end deflection

If unable to measure valve guide inside diameter, measure "Valve stem end deflection".



09900-20602 : Dial gauge

09900-20701 : Magnetic stand

Measure valve stem end deflection as follows :

1. Install valve into valve guide.
2. Position valve head at approx. 5mm away from valve seat.
3. Move stem end in the direction "X - Y", and measure deflection.

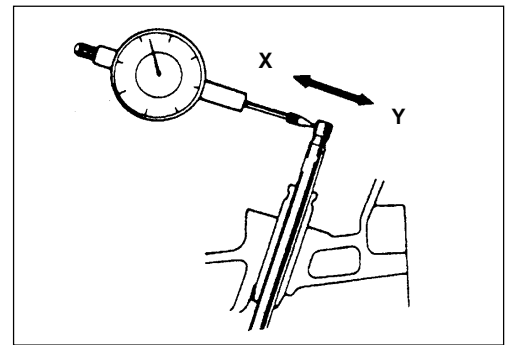
**Valve stem end deflection :****Service limit :**

IN 0.14 mm (0.006 in.)

EX 0.18 mm (0.007 in.)

If measurement exceeds service limit, replace valve.

If measurement still exceeds service limit with new valve, replace valve guide.

Valve stem end

Inspect valve stem end face for pitting and wear.

If pitting or wear is found, valve stem end may be resurfaced.

Use caution when resurfacing, do not grind away stem end chamfer.

When chamfer has been worn away, replace valve.

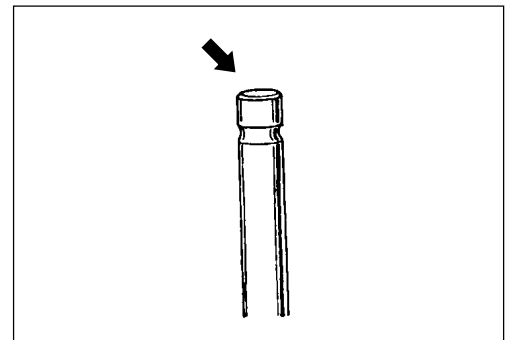

Valve stem runout

Measure valve stem runout.

-  **09900-20602 : Dial gauge**
- 09900-20701 : Magnetic stand**
- 09900-21304 : "V" block set**

Valve stem runout :
Service limit : 0.05 mm (0.002 in.)

If measurement exceeds service limit, replace valve.

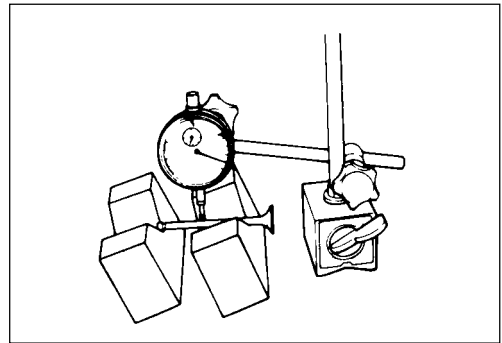

Valve head radial runout

Measure valve head radial runout.

-  **09900-20602 : Dial gauge**
- 09900-20701 : Magnetic stand**
- 09900-21304 : "V" block set**

Valve head radial runout :
Service limit : 0.08 mm (0.003 in.)

If measurement exceeds service limit, replace valve.

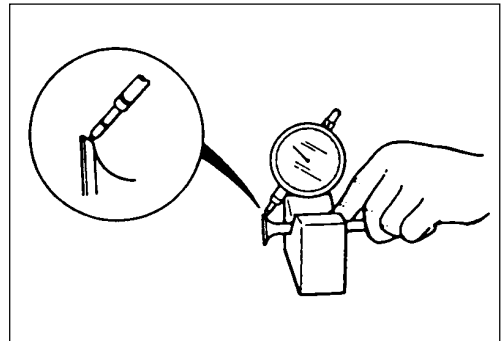

Valve head thickness

Measure thickness $\text{\textcircled{T}}$ of valve head.

-  **09900-20101 : Vernier calipers**

Valve head thickness :

Standard :

IN	1.0 mm (0.04 in.)
EX	1.2 mm (0.05 in.)

Service limit :

IN	0.7 mm (0.03 in.)
EX	0.7 mm (0.03 in.)

If measurement exceeds service limit, replace valve.

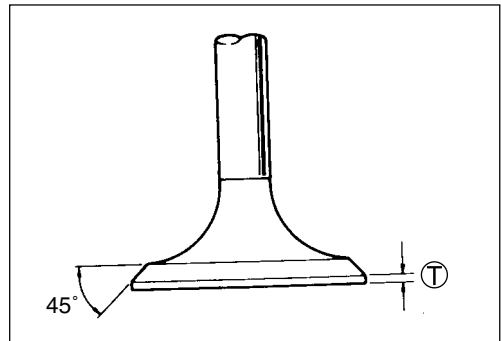

Valve seat contact width

Measure valve seat contact width as follows :

1. Remove all carbon from valve and seat.
2. Coat valve seat evenly with Prussian blue (or equivalent).
3. Install valve into valve guide.
4. Put valve lapper on valve.

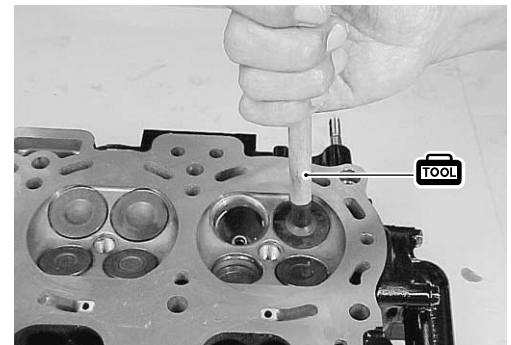

 **09916-10911 : Valve lapper**

5. Rotate valve while gently tapping valve contact area against seat.
6. Continuously pattern on valve seating face with Prussian blue.
7. Measure valve seat contact width (A).

 **09900-20101 : Vernier calipers**

Valve seat contact width (A) :

Standard :

IN 1.1 – 1.3 mm (0.04 – 0.05 in.)

EX 1.1 – 1.3 mm (0.04 – 0.05 in.)

If measurement exceeds specification, repair valve seat.

NOTE:

For valve seat repair, see “Valve seat servicing” section on page 6-34.

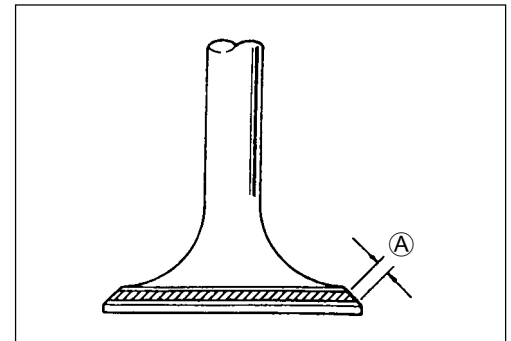

VALVE SEAT SERVICING

If valve seat contact width is out of specification, reface valve seat as follows :

Valve seat angle :

Intake side : 15°, 45°, 60°

Exhaust side : 15°, 45°

-  **09916-20620** : Valve seat cutter (NEWAY122) 45°
09916-20610 : Valve seat cutter (NEWAY121) 15°
09916-22420 : Valve seat cutter (NEWAY 114) 60°
Solid pilot (NEWAY. N-120-6.0)
09916-54910 : Handle (N-505)

NOTE:

Turn cutter clockwise, never counterclockwise.

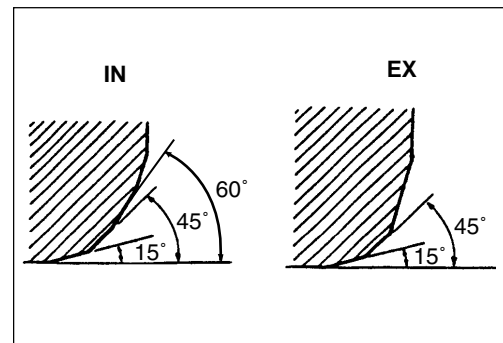

1. Remove all carbon from valve and valve seat.
2. Using 45° angle cutter, reface valve seat.
3. Check valve seat contact width (A).
(See page 6-33)
 - If width (A) is too high (or wide), reface valve seat using 15° angle cutter. (Intake side, Exhaust side)
 - If width (A) is too low (or narrow), reface valve seat using 45° angle cutter. (Exhaust side)
 - If width (A) is too low (or narrow), reface valve seat using 60° angle cutter. (Intake side)
4. Clean up any burrs using 45° angle cutter very lightly.

CAUTION

**Grind seat areas minimally only.
Do not grind more than necessary.**

5. Lap valve on seat in two steps, first with coarse grit lapping compound applied to face and the second with fine grit compound.
6. Recheck valve seat contact width (A).

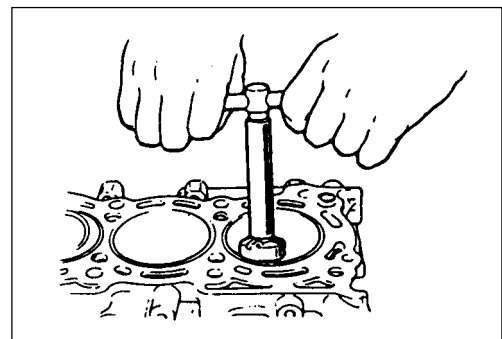
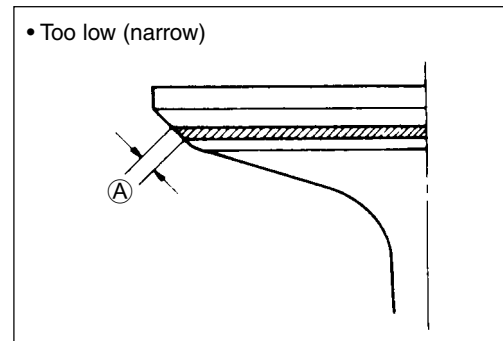
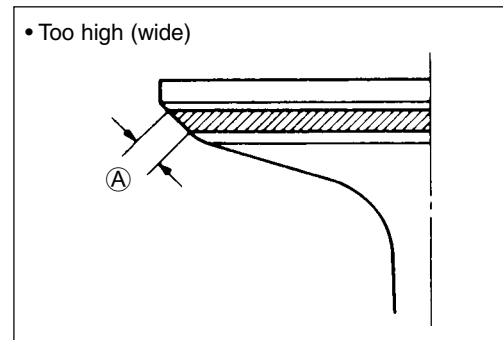

NOTE:

Clean and assemble cylinder head and valve components.
 Fill intake and exhaust ports with solvent to check for leaks between valve seat and valve.
 If any leaks occur, inspect valve seat and face for burrs or other things that could prevent valve from sealing.

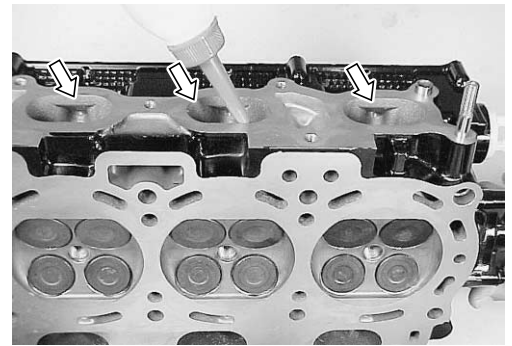
**VALVE GUIDE REPLACEMENT****CAUTION**

Be careful not to damage cylinder head when replacing valve guide.

1. Using valve guide remover, drive valve guide out from combustion chamber side towards valve spring side.

 **09916-46020 : Valve guide remover**

NOTE:

Do not reuse valve guide once it has been removed.
 Always use a new valve guide (oversize) when assembling.

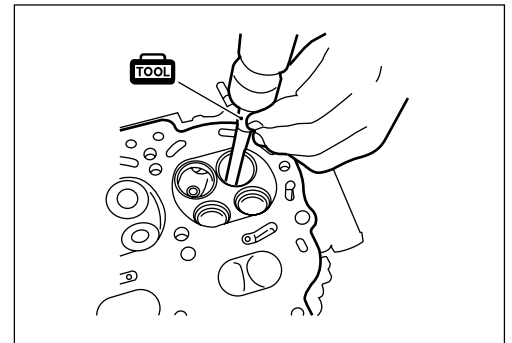

2. Ream valve guide hole with $\phi 11$ mm reamer to true hole and remove burrs.

 **09916-38210 : Valve guide reamer ($\phi 11$ mm)**
09916-34542 : Reamer handle

NOTE:

Turn reamer clockwise, never counterclockwise.

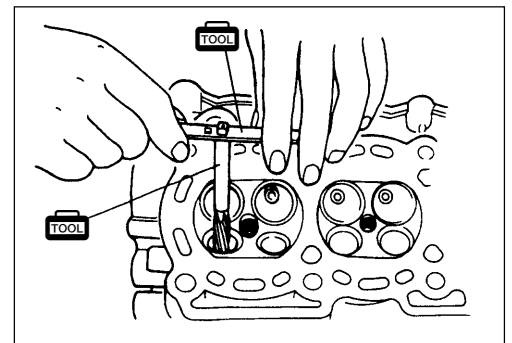



3. Install valve guide to cylinder head as follows.

(1) Heat cylinder head to a temperature of 80 – 100°C (176 – 212°F).
Apply heat uniformly so that head will not be distorted.

(2) Use special tools to drive new valve guide into hole.
Drive in new valve guide until special tool (valve guide installer attachment) contacts cylinder head.

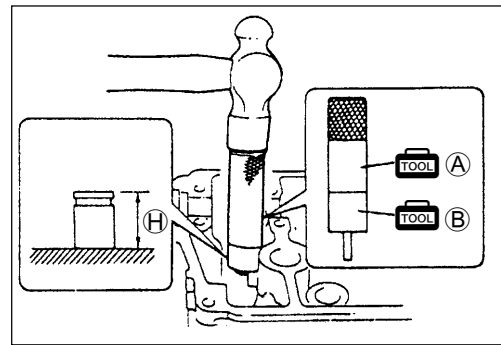
(3) After installing, check valve guide protrusion H .



 **09916-57350 : Valve guide installer handle A**

09917-87810 : Valve guide installer attachment B

Valve guide protrusion H :

Standard :

IN & EX 13.5 mm (0.53 in.)

4. Ream valve guide bore with $\phi 6$ mm reamer.

 **09916-37810 : Valve guide reamer ($\phi 6$ mm)**

09916-34542 : Reamer handle

NOTE:

Clean and oil valve guide bore after reaming.

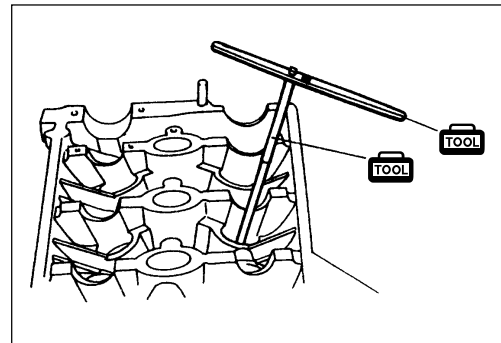

VALVE SPRING**Valve spring free length**

Measure valve spring free length.

 **09900-20101 : Vernier calipers**

Valve spring free length :**Standard :**

IN & EX 42.7 mm (1.68 in.)

Service limit :

IN & EX 41.0 mm (1.61 in.)

If measurement exceeds service limit, replace valve spring.

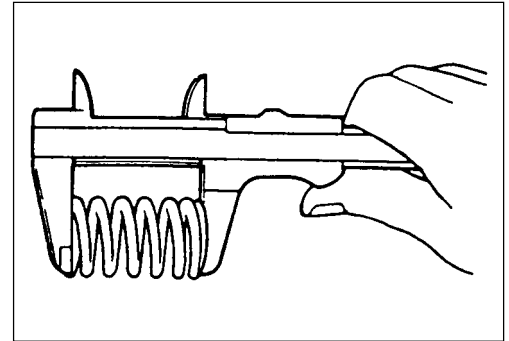
**Valve spring preload**

Measure valve spring preload.

 **09900-20101 : Vernier calipers**

Valve spring preload :**Standard :**

**IN & EX 167 –193 N (16.7 – 19.3 kg , 36.8 – 42.5 lbs.)
for 32.6 mm (1.28 in.)**

Service limit :

**IN & EX 151 N (15.1 kg, 33.3 lbs.)
for 32.6 mm (1.28 in.)**

If measurement exceeds service limit, replace valve spring.

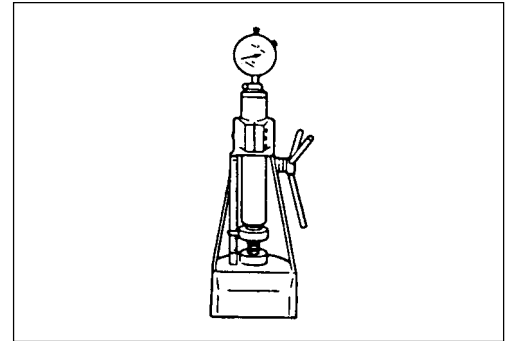
**Valve spring squareness**

Using a square and surface plate, measure each spring for squareness (clearance between end of valve spring and square).

 **09900-20101 : Vernier calipers**

Valve spring squareness :**Service limit :**

IN & EX 2.0 mm (0.08 in.)

If measurement exceeds service limit, replace valve spring.

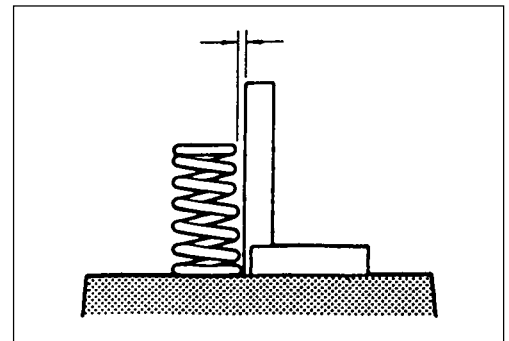

REASSEMBLY

Reassemble in reverse order of disassembly with special attention to the following steps.

VALVE

1. Install valve spring seat ① to cylinder head.

2. After applying engine oil to stem seal ② and spindle of special tool (Installer attachment), fit stem seal to spindle. Then, pushing special tool by hand, install stem seal to valve guide.
3. Check to be sure that seal is properly fixed to valve guide.

 **09917-98221 : Installer attachment ①**
09916-57350 : Installer handle ②

CAUTION

**Do not re-use stem seal once removed.
 Always use a new stem seal.**

4. Apply engine oil to stem seal, valve guide bore and valve stem.

5. Install valve ③ to valve guide.

NOTE:

Reassemble each valve and valve spring to their original position.

6. Install valve spring ④, and valve retainer ⑤.

NOTE:

Set valve spring in place with narrow spiral area facing valve seat.

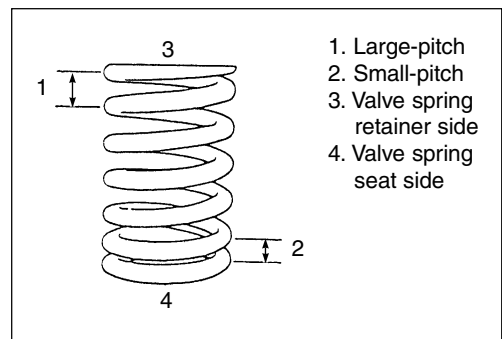
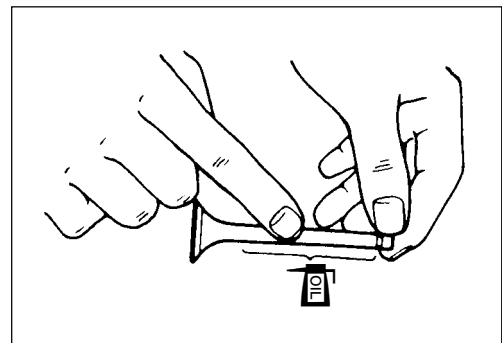
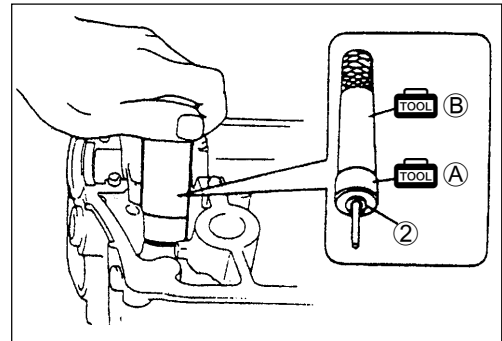
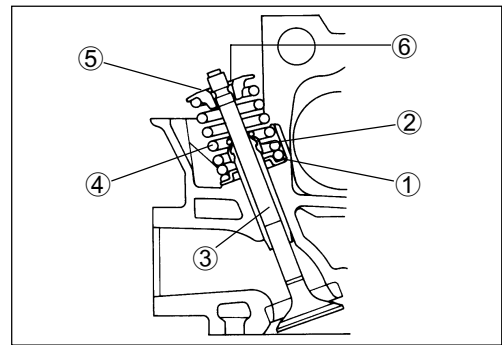

7. Hold valve spring compressed with special tool and install valve cotters ⑥.
8. Make sure valve cotters are properly seated in groove ①.

 **09916-19030 : Valve lifter**
09916-14910 : Attachment
09916-84511 : Tweezers

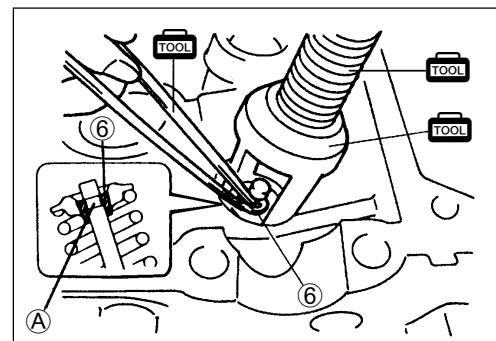
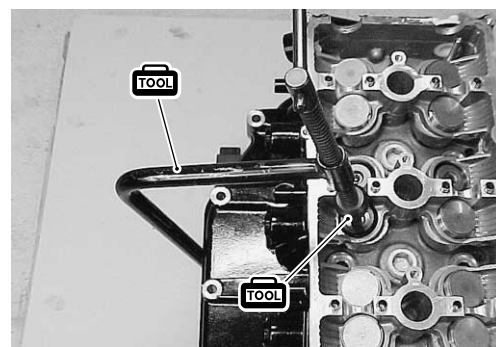

CYLINDER / CRANKSHAFT / PISTON

DISASSEMBLY

Before performing service work in this section :

- Remove power unit (See page 6-5 to 6-8)
- Remove timing chain (See page 6-14 to 6-15)
- Remove cylinder head (See page 6-20)

1. Remove driven gear.



2. Remove oil filter.

 09915-47330 : Oil filter wrench

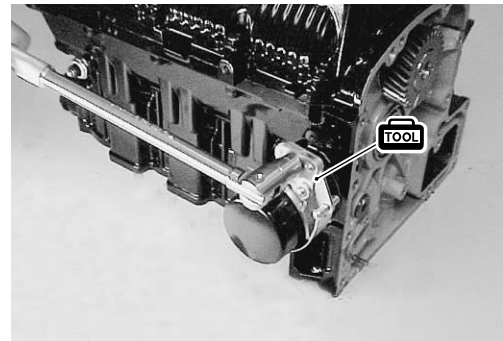

3. Remove oil pressure switch.

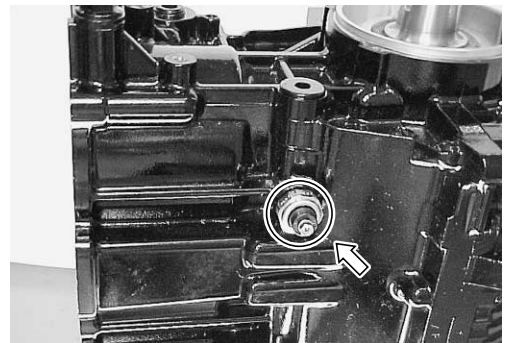

4. Remove ten (10) bolts ①.
Remove ten (10) bolts ②.

NOTE:

Removal (loosening order) is reverse of installation (tightening order). See page 6-62.

5. Remove crankcase from cylinder block.

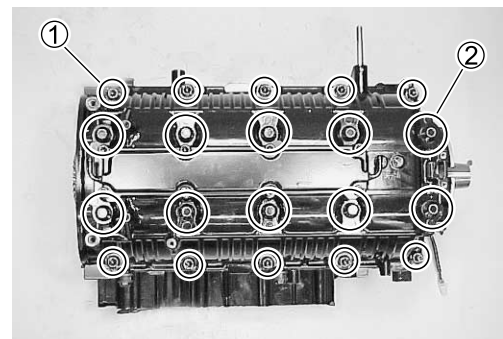

NOTE:

For proper assembly, mark cylinder number on all pistons, conrods, and conrod caps, using quick drying paint.

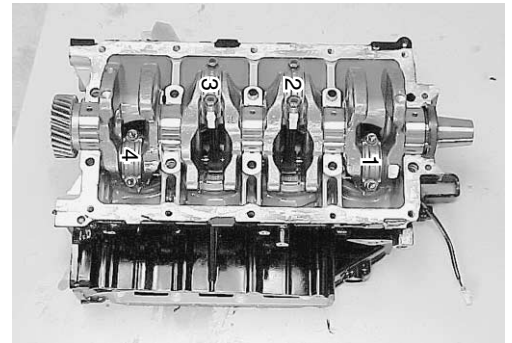

6. Remove all conrod cap nuts ① and conrod caps ②.

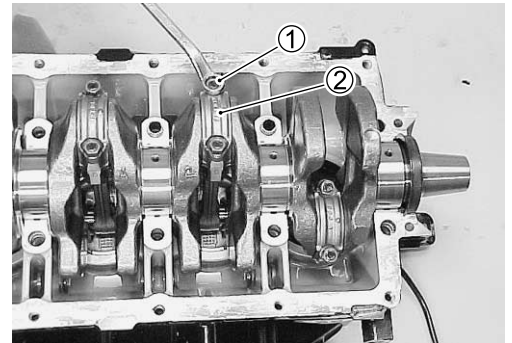
**NOTE:**

To prevent damage to crank pin and cylinder walls, install a piece of hose over threads of rod bolts.

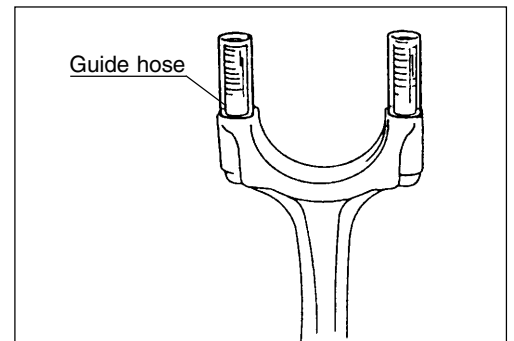

7. Remove crankshaft ③.
8. Remove oil seal ④ from crankshaft.

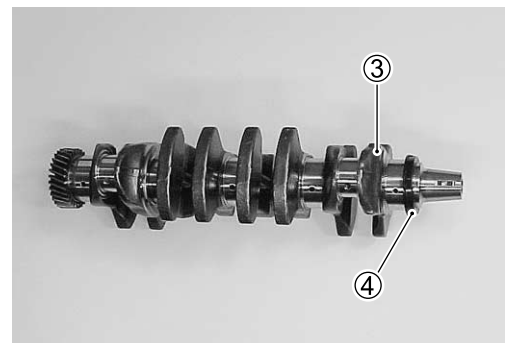

9. Mark cylinder number on pistons using quick dry paint.
10. Push piston (with conrod) out through the top of cylinder bore.

NOTE:

- To prevent damage to piston rings, decarbon top of cylinder bore wall before removing piston.
- Reassemble each conrod cap to its original position after removing piston from bore.

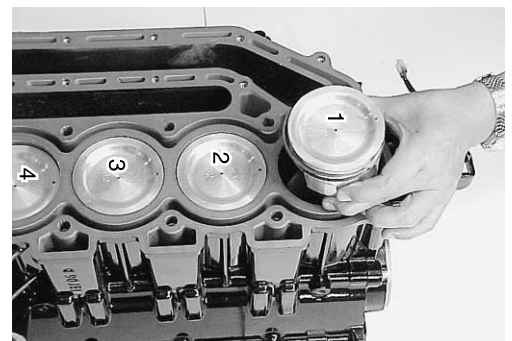

11. Remove two compression rings (top and 2nd) and oil ring from piston.

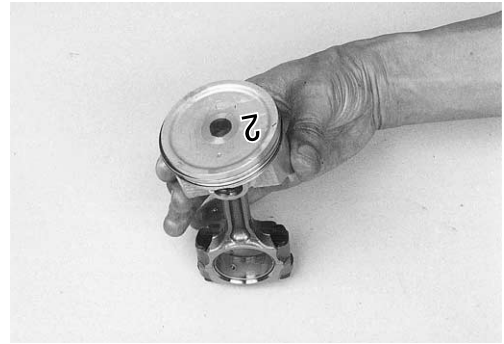

12. Mark cylinder number on conrod using quick dry paint.

13. Remove piston pin circlips as shown.

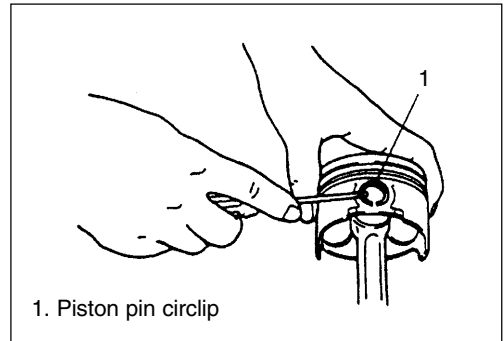

14. Remove piston pin from conrod.

NOTE:

Reassemble each piston, piston pin and conrod in their original combination and position.

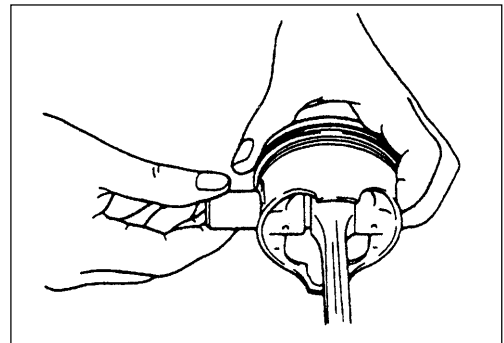

INSPECTION / SERVICING

NOTE:

If cracks, excessive wear or other damage is found on any component, replace component.

CYLINDER

Cylinder distortion

Using a straightedge and thickness gauge, measure cylinder distortion (gasketed surface) at a total of six (6) locations as shown in figure.

 09900-20803 : Thickness gauge

Cylinder distortion :

Service limit : 0.05 mm (0.002 in.)

If measurement exceeds service limit, resurface or replace cylinder.

NOTE:

Cylinder can be resurfaced, using a surface plate and # 400 grit wet sandpaper.

Move cylinder in a figure eight pattern when sanding.

Water jackets

Inspect water jackets for clog or obstruction.

Clean water jacket if necessary.

Driven gear / bearing

Inspect driven gear for wear or other damage.

Replace if necessary.

Inspect driven gear bearing for pitting, rough or other damage.

Replace if necessary.

① Driven gear ② Plug ③ O-ring ④ Circlip

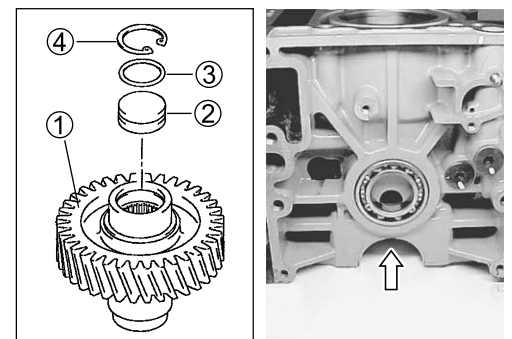
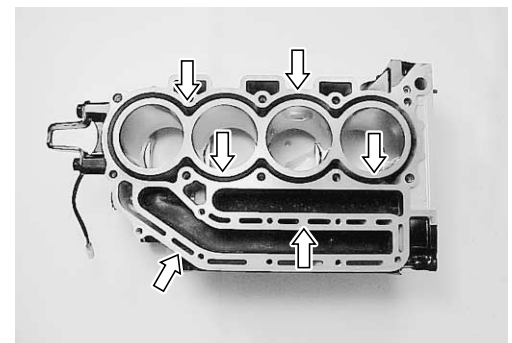
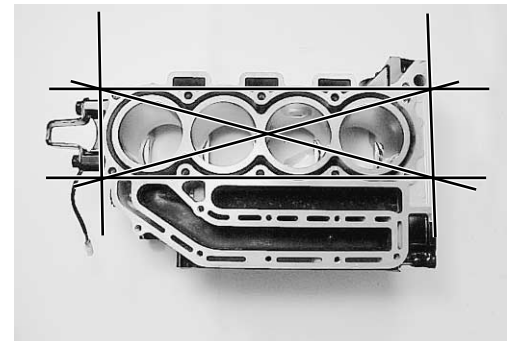
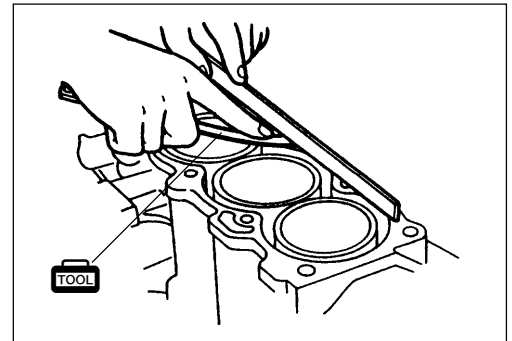

Cylinder bore

Inspect cylinder walls for scratches, roughness, or ridges which indicate excessive wear.

If cylinder bore is very rough or deeply scratched, or ridged, rebore cylinder and use oversize piston.

Cylinder bore wear (difference)

Using cylinder gauge, measure cylinder bore in both axial (vertical line, following crankshaft) and transverse (horizontal line across crankshaft) directions at two positions as shown in figure.

 **09900-20508 : Cylinder gauge set**

Check for following :

- Difference between measurements at the two positions (taper).
- Difference between axial and transverse measurement (out-of-round).

Cylinder bore wear (difference) :
Service limit : 0.10 mm (0.039 in.)

If measurement exceeds service limit, rebore or replace cylinder.

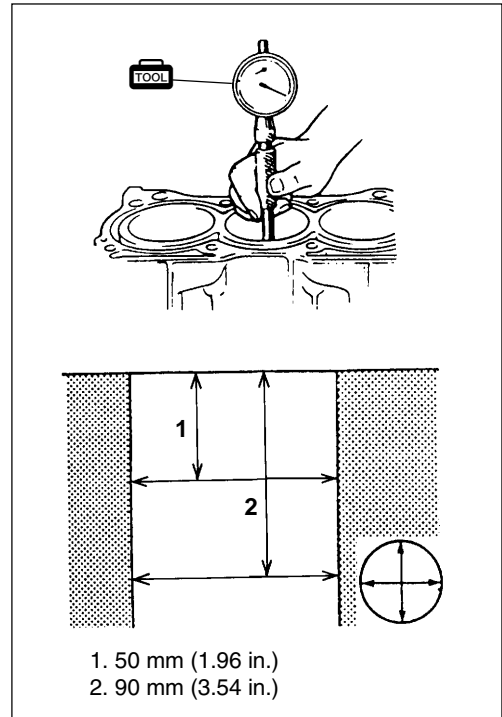

PISTON TO CYLINDER CLEARANCE

1. Measure piston diameter at a point 26.5 mm (1.04 in.) above piston skirt at a right angle to piston pin bore.

 **09900-20204 : Micrometer**

Piston skirt diameter :
Standard : 83.970 – 83.990 mm (3.3059 – 3.3067 in.)

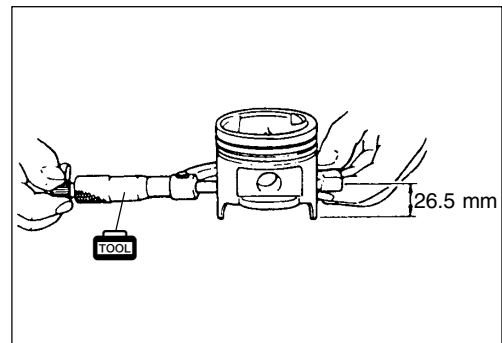

2. Measure cylinder bore at 50 mm (2.0 in.) below cylinder head gasket surface at a right angle to crankshaft pin.

 **09900-20508 : Cylinder gauge set**

Cylinder bore :
Standard : 84.000 – 84.020 mm (3.3071 – 3.3079 in.)

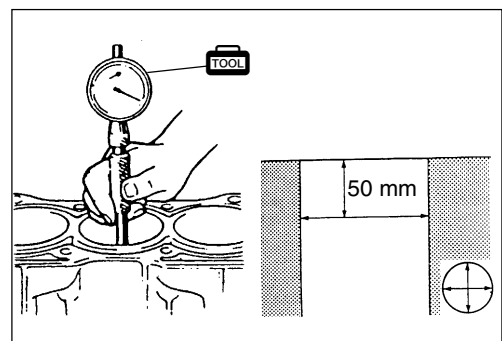

- Calculate the piston / cylinder clearance (Clearance equals difference between piston diameter and cylinder bore measurements).

Piston to cylinder clearance :

Standard : 0.020 – 0.040 mm (0.0008 – 0.0016 in.)

Service limit : 0.100 mm (0.0039 in.)

If clearance exceeds service limit, replace piston and/or cylinder or rebore cylinder.

Identification of oversize piston / piston ring

Two oversize piston / piston ring components, 0.25 mm and 0.50 mm, are available.

Oversize piston / piston ring are marked as shown below.

• **Piston**

Oversize	I.D. mark
0.25 mm	0.25
0.50 mm	0.50

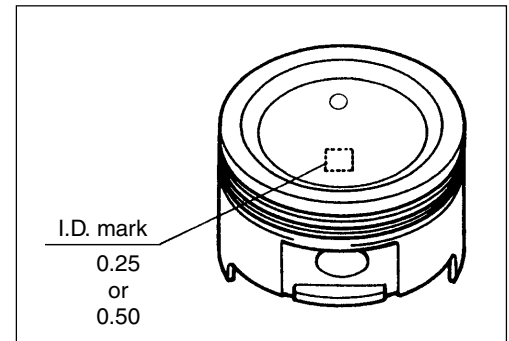

• **1st & 2nd Piston ring**

Oversize	I.D. mark
0.25 mm	25
0.50 mm	50

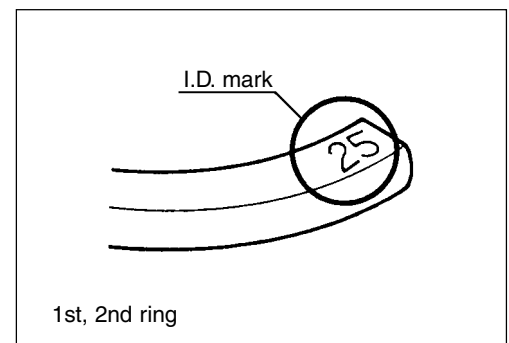

• **Oil ring**

Oversize	I.D. mark
0.25 mm	Two (2) blue paints
0.50 mm	Red paint

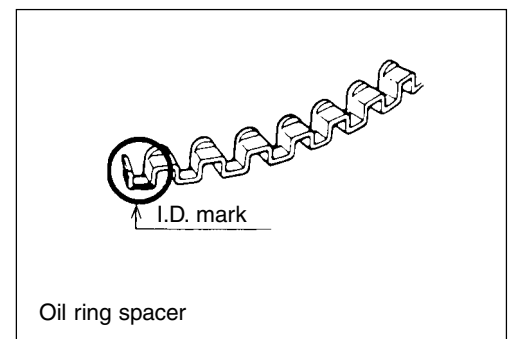

PISTON

Inspect piston for faults, cracks or other damage.

Replace if necessary.

Piston ring to groove clearance

Before checking, piston grooves should be clean, dry and free of carbon.

Fit piston ring into piston groove, and measure clearance between ring and ring groove using thickness gauge.

 **09900-20803 : Thickness gauge**

Piston ring to groove clearance :**Standard :**

1 st 0.030 – 0.070 mm (0.0012 – 0.0028 in.)

2 nd 0.020 – 0.060 mm (0.0008 – 0.0024 in.)

Service limit :

1 st 0.12 mm (0.005 in.)

2 nd 0.10 mm (0.004 in.)

If measurement exceeds service limit, replace piston and/or piston ring.

Piston ring groove width :**Standard :**

1 st 1.22 – 1.24 mm (0.048 – 0.049 in.)

2 nd 1.51 – 1.53 mm (0.059 – 0.060 in.)

Oil 2.51 – 2.53 mm (0.099 – 0.100 in.)

Piston ring thickness :**Standard :**

1 st 1.17 – 1.19 mm (0.046 – 0.047 in.)

2 nd 1.47 – 1.49 mm (0.058 – 0.059 in.)

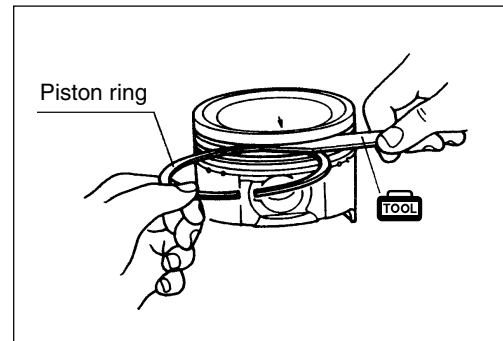

PISTON RING**Piston ring end gap**

Measure piston ring end gap with piston ring in the lowest position of cylinder bore.

 **09900-20803: Thickness gauge**

Piston ring end gap :**Standard :**

1 st 0.20 – 0.35 mm (0.008 – 0.014 in.)

2 nd 0.35 – 0.50 mm (0.014 – 0.020 in.)

Service limit :

1 st 0.70 mm (0.028 in.)

2 nd 1.00 mm (0.040 in.)

If measurement exceeds service limit, replace piston ring.

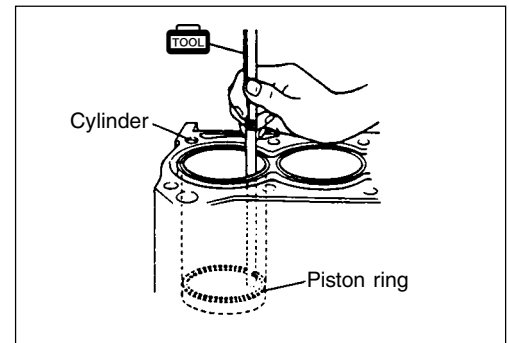
**Piston ring free end gap**

Measure piston ring free end gap using vernier calipers.

 **09900-20101 : Vernier calipers**

Piston ring free end gap :**Standard :**

1 st Approx. 11.3 mm (0.44 in.)

2 nd Approx. 11.0 mm (0.43 in.)

Service limit :

1 st 9.0 mm (0.354 in.)

2 nd 8.8 mm (0.347 in.)

If measurement exceeds service limit, replace piston ring.

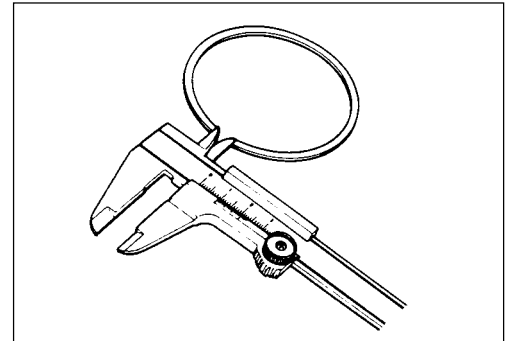

PISTON PIN

Inspect piston pin, conrod small end bore and piston pin hole for wear or other damage.

Replace if necessary.

Piston pin clearance

Measure piston pin clearance in conrod small end.

Replace conrod if its small end is badly worn or damaged or if clearance exceeds service limit.

 **09900-20205 : Micrometer**
09900-20605 : Dial calipers

Piston pin outside diameter :

Standard : 20.997 – 21.000 mm (0.8267 – 0.8268 in.)

Service limit : 20.980 mm (0.8260 in.)

Piston pin hole diameter :

Standard : 21.006 – 21.014 mm (0.8270 – 0.8273 in.)

Service limit : 21.040 mm (0.8283 in.)

Conrod small end bore :

Standard : 21.003 – 21.011 mm (0.8269 – 0.8272 in.)

Pin clearance in piston pin hole :

Standard : 0.006 – 0.017 mm (0.0002 – 0.0007 in.)

Service limit : 0.040 mm (0.0016 in.)

Pin clearance in conrod small end :

Standard : 0.003 – 0.014 mm (0.0001 – 0.0006 in.)

Service limit : 0.050 mm (0.0020 in.)

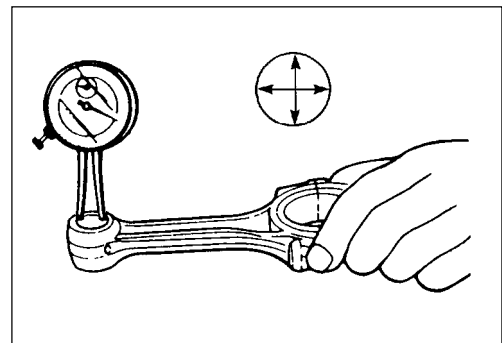
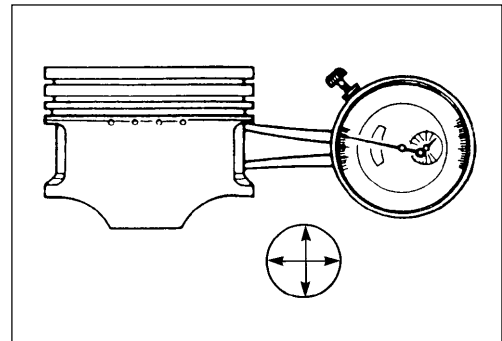
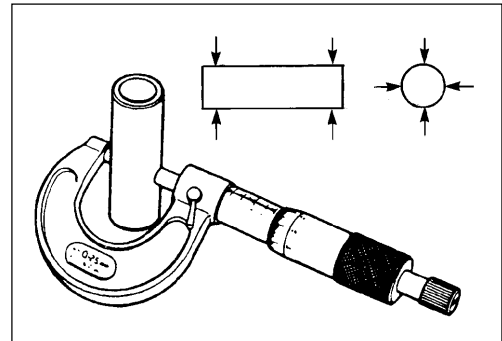

CONROD BIG END SIDE CLEARANCE

Measure conrod big end side clearance with conrod installed on crank pin as shown in figure.

 **09900-20803 : Thickness gauge**

Conrod big end side clearance :

Standard : 0.100 – 0.250 mm (0.0039 – 0.0098 in.)

Service limit : 0.350 mm (0.0138 in.)

If measurement exceeds service limit, replace conrod and/or crankshaft.

Conrod big end width :

Standard : 21.950 – 22.000 mm (0.8642 – 0.8661 in.)

Crank pin width :

Standard : 22.100 – 22.200 mm (0.8700 – 0.8740 in.)

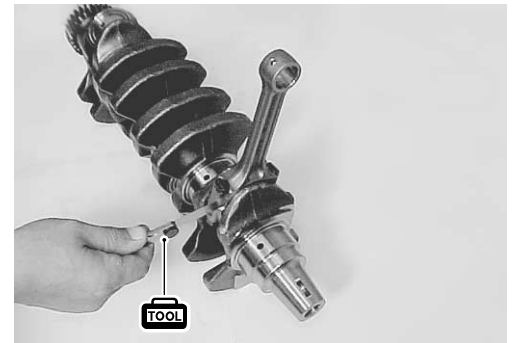
**CRANK PIN**

Inspect crank pin for uneven wear or other damage.

Measure crank pin for out-of-round or taper with micrometer.

If any crank pin is damaged or if measurements exceed service limit, replace crankshaft.

 **09900-20202 : Micrometer**

Out-of-round : $A - B$

Taper : $a - b$

Out-of-round and taper :

Service limit : 0.010 mm (0.0004 in.)

Crank pin diameter :

Standard : 43.982 – 44.000 mm (1.7316 – 1.7323 in.)

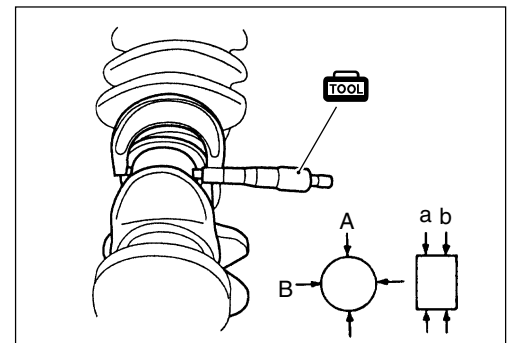

CONROD BEARING

Inspect bearings for proper contact pattern and signs of fusion, pitting, burning or flaking.
 Replace if necessary.
 Always replace both bearing halves, never replace only one half of a bearing set.

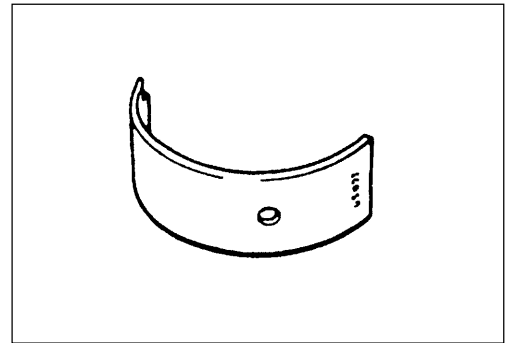

Conrod big end oil clearance

Check conrod big end oil clearance as follows :

1. Clean surface of conrod, conrod cap, conrod bearing, and crank pin.
2. Install conrod bearing onto conrod and conrod cap.

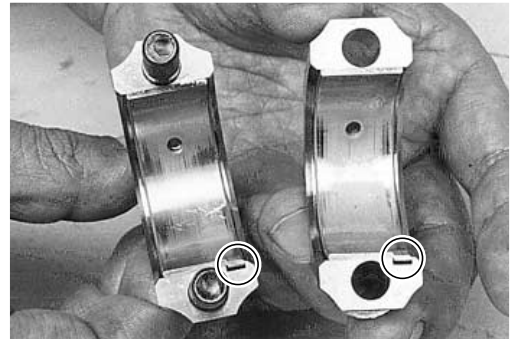

NOTE:

- Reassemble each bearing and conrod cap to their original position.
- Do not apply oil to bearing.

3. Place a piece of Plastigauge on crank pin parallel to crankshaft. Do not place Plastigauge over oil hole.



 **09900-22301 : Plastigauge (0.025 — 0.076 mm)**

4. Install conrod cap (with bearing) to conrod with dot (•) mark on cap toward flywheel side.

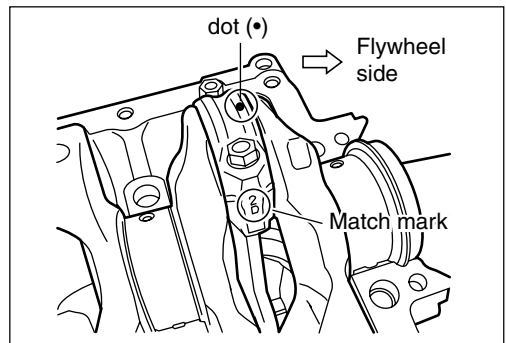

5. Apply engine oil lightly to conrod bolts and tighten nut in two steps.

 **Conrod cap nut :**

- 1 st step 18 N·m (1.8 kg-m, 13.0 lb.-ft.)**
- Final step 35 N·m (3.5 kg-m, 25.5 lb.-ft.)**

NOTE:

Do not rotate conrod while Plastigauge is installed.

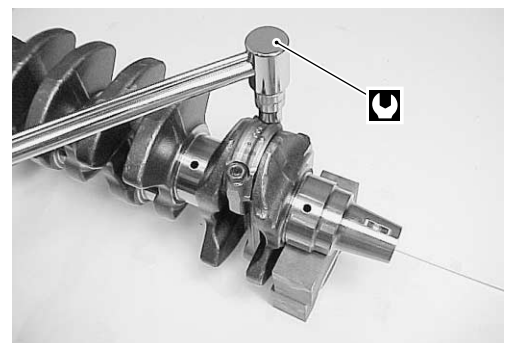

6. Remove conrod and conrod cap from crank pin.
7. Using scale on Plastigauge envelope, measure Plastigauge width at its widest point.

Conrod big end oil clearance :

Standard : 0.020 – 0.040 mm (0.0008 – 0.0016 in.)

Service limit : 0.065 mm (0.0026 in.)

If measurement exceeds service limit, replace conrod bearing.

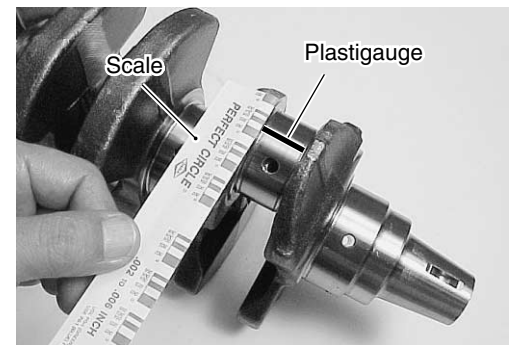

CRANKSHAFT

Crankshaft runout

Using a dial gauge, measure runout at center journal.

TOOL 09900-20602 : Dial gauge
09900-20701 : Magnetic stand

Crankshaft runout :

Service limit : 0.04 mm (0.002 in.)

If measurement exceeds service limit, replace crankshaft.

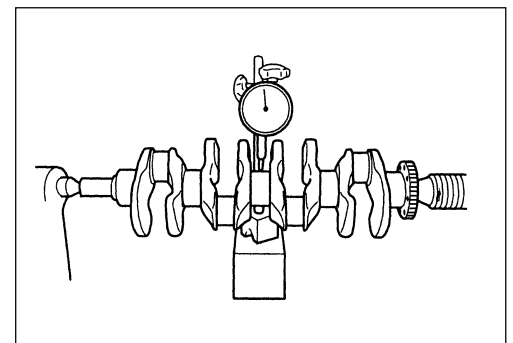

Crankshaft thrust play

Measure thrust play with crankshaft, thrust bearing, journal bearing and crankcase/cylinder block assembled in a normal manner.

Tighten crankcase bolts to specified torque.

CRANKCASE BOLT Crankcase bolt :
8 mm 25 N·m (2.5 kg-m, 18.0 lb.-ft.)
10 mm 56 N·m (5.6 kg-m, 40.5 lb.-ft.)

Using a dial gauge, measure displacement in axial (thrust) direction of crankshaft.

Crankshaft thrust play :

Standard : 0.11 – 0.31 mm (0.004 – 0.012 in.)

Service limit : 0.35 mm (0.014 in.)

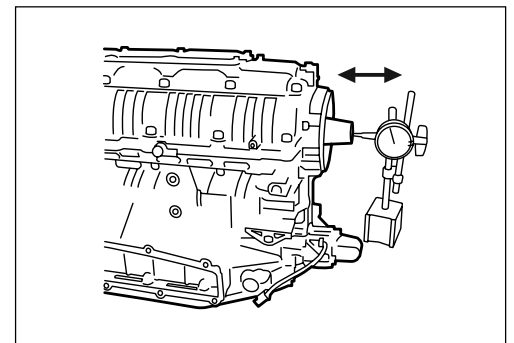

If measurement exceeds service limit, replace crankshaft thrust bearing.

Crankshaft thrust bearing thickness :
Standard : 2.425 – 2.475 mm (0.0955 – 0.0974 in.)

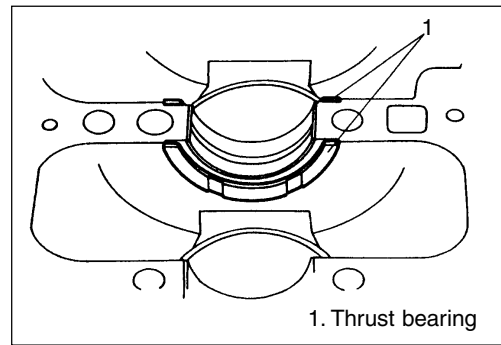

1. Thrust bearing

Out-of-round and taper (uneven wear) of journals

Inspect crankshaft journal for uneven wear or other damage. Measure journal for out-of-round or taper with micrometer. If any journal is damaged or if measurements exceed service limit, replace crankshaft.

 **09900-20203 : Micrometer**

Out-of-round : A – B

Taper : a – b

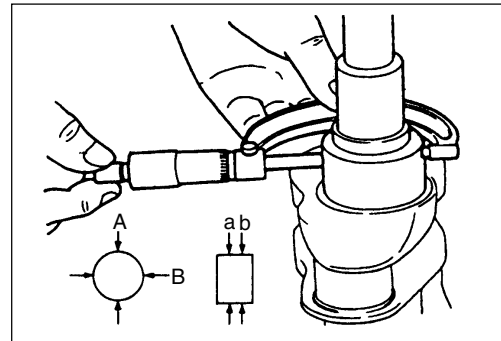

Out-of-round and taper :

Service limit : 0.010 mm (0.0004 in.)

Crankshaft journal outside diameter :

Standard : 57.994 – 58.012 mm (2.2832 – 2.2839 in.)

CRANKSHAFT MAIN BEARING

Inspect bearings for proper contact pattern and signs of fusion, pitting, burning or flaking.

Replace if necessary.

Always replace both bearing halves, never replace only one half of a bearing set.

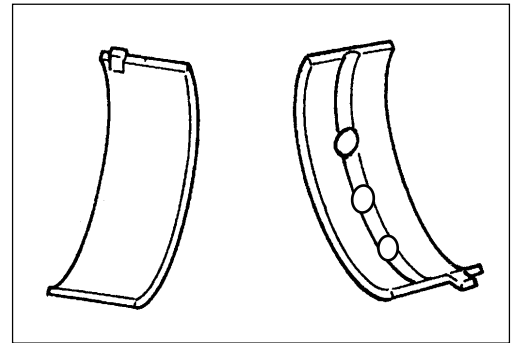

CRANKSHAFT JOURNAL OIL CLEARANCE

Check crankshaft journal oil clearance as follows:

1. Clean surface of bearing holder (crankcase and cylinder), bearing and main bearing journal.
2. Install main bearing to cylinder and crankcase.

NOTE:

- Assemble each bearing in its original position before checking clearance.
- Align the tab **@** of bearing with notch in cylinder and crankcase.
- Do not apply engine oil to bearing.
- Install bearing half with oil hole / groove to cylinder side.

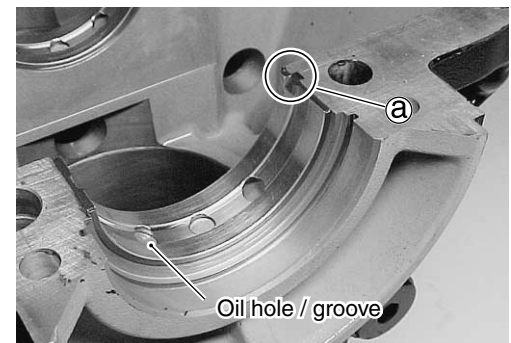
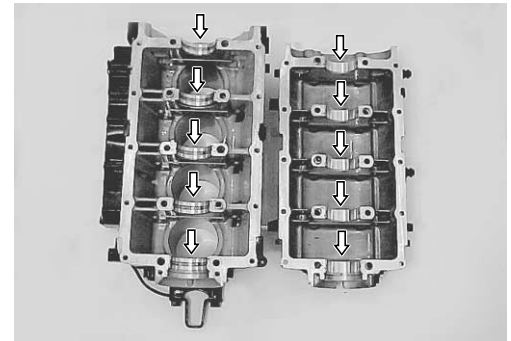

3. Install crankshaft to cylinder.
4. Place a piece of Plastigauge on journal parallel to crankshaft. Do not place Plastigauge over oil hole.

 **09900-22301 : Plastigauge (0.025 — 0.076 mm)**

NOTE:

Do not rotate crankshaft while Plastigauge is installed.

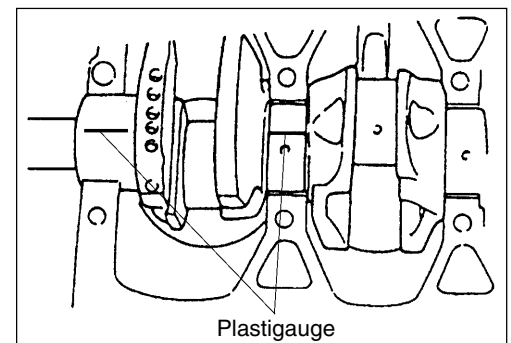

5. Install crankcase to cylinder.
6. Apply engine oil lightly to crankcase bolts.
Tighten crankcase bolts in three (3) steps according to the order shown below and in figure.

🔩 Crankcase bolt :

1st step	8 mm	5 N·m (0.5 kg-m, 3.5 lb.-ft.)
	10 mm	11 N·m (1.1 kg-m, 8.0 lb.-ft.)
2nd step	8 mm	20 N·m (2.0 kg-m, 14.5 lb.-ft.)
	10 mm	43 N·m (4.3 kg-m, 31.0 lb.-ft.)
Final step	8 mm	25 N·m (2.5 kg-m, 18.0 lb.-ft.)
	10 mm	56 N·m (5.6 kg-m, 40.5 lb.-ft.)

NOTE:

- *Crankcase should be torqued to specification in order to assure proper compression of Plastigauge and accurate reading of clearance.*
- *Do not rotate crankshaft while Plastigauge is installed.*

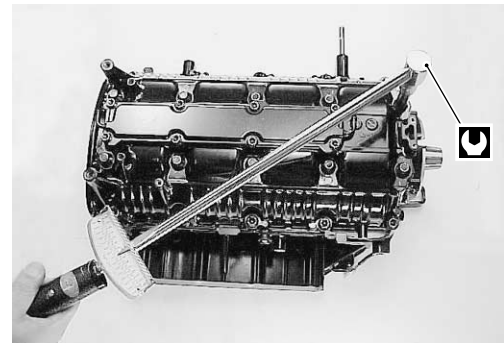
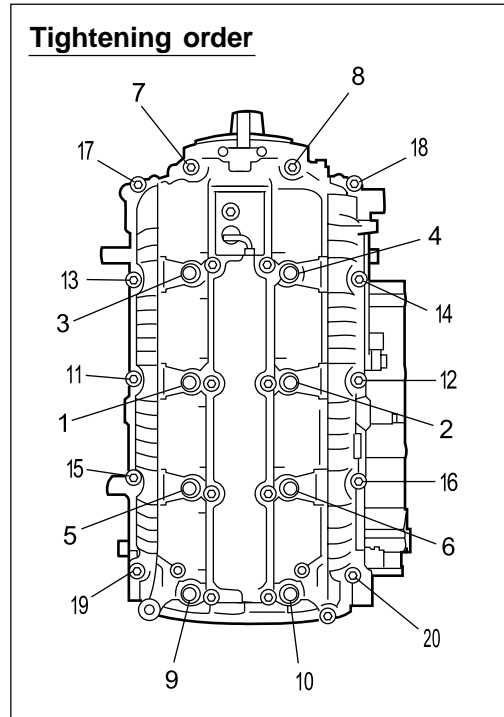

7. Remove crankcase from cylinder.
8. Using scale on Plastigauge envelope, measure Plastigauge width at its widest point.

Crankshaft journal oil clearance :

Standard : 0.020 – 0.040 mm (0.0008 – 0.0016 in.)
Service limit : 0.065 mm (0.0026 in.)

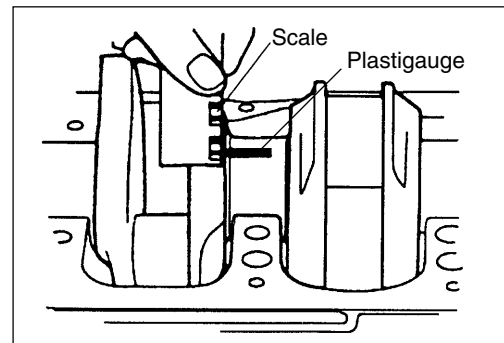

If measurement exceeds service limit, replace crankshaft main bearing.

NOTE:

For bearing replacement, see “SELECTION OF MAIN BEARING” section on page 6-55.

SELECTION OF MAIN BEARING

Whenever a bearing requires replacement, select a new bearing according to following procedure.

1. First, check journal diameter.

As shown in figure, upper (flywheel side) crank web of No.1 cylinder has five (5) stamped code numerals.

The numerals (1, 2 & 3) represent journal diameters shown below.

Numeral stamped	Journal diameter
1	58.006 – 58.012 mm (2.2837 – 2.2839 in.)
2	58.000 – 58.006 mm (2.2835 – 2.2837 in.)
3	57.994 – 58.000 mm (2.2832 – 2.2835 in.)

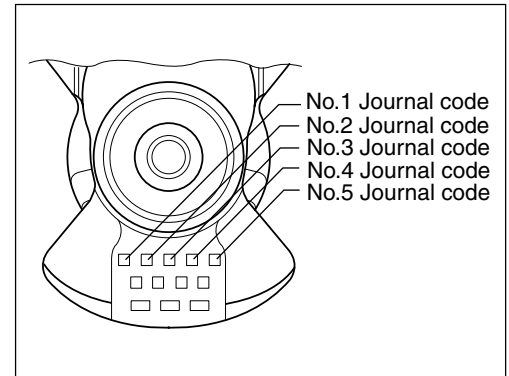

2. Next, check bearing holder inside diameter without bearing.

As shown in figure, PORT side of cylinder block has five (5) stamped codes letters.

The letters (A, B & C) represent bearing holder inside diameters shown below.

Code	Crank bearing holder inside diameter (w / o bearing)
A	62.000 – 62.006 mm (2.4409 – 2.4412 in.)
B	62.006 – 62.012 mm (2.4412 – 2.4414 in.)
C	62.012 – 62.018 mm (2.4414 – 2.4416 in.)

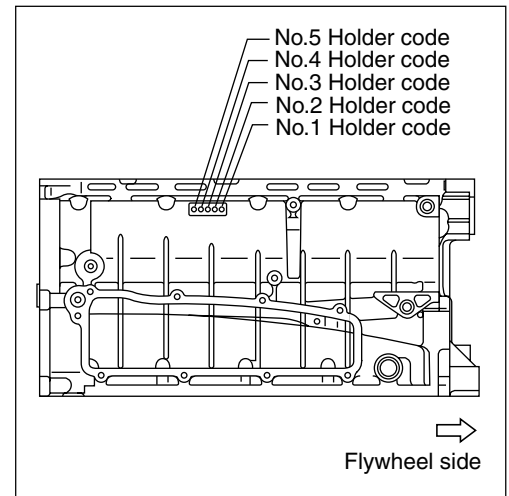

3. There are five (5) main bearings available, each of differing thickness.

To distinguish them, a color mark is painted at position indicated in figure.

Each color represents the following thickness measured at center of bearing.

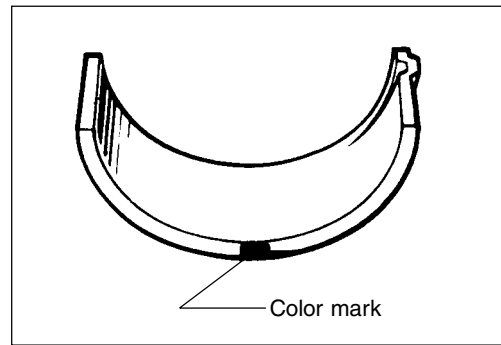

Color mark	Bearing thickness
Green	1.990 – 1.994 mm (0.0783 – 0.0785 in.)
Black	1.993 – 1.997 mm (0.0785 – 0.0786 in.)
No Color mark	1.996 – 2.000 mm (0.0786 – 0.0787 in.)
Yellow	1.999 – 2.003 mm (0.0787 – 0.0789 in.)
Blue	2.002 – 2.006 mm (0.0788 – 0.0790 in.)

4. Select crankshaft main bearing referring below table.

		Numeral stamped on crank web (journal outside diameter)		
		1	2	3
Code stamped on cylinder block (Bearing holder inside diameter)	A	Green	Black	No Color
	B	Black	No Color	Yellow
	C	No Color	Yellow	Blue

NOTE:

Measure crankshaft journal oil clearance again after installing new bearings selected. (See page 6-53)

OIL SEAL

Inspect oil seal for crack, cut or other damage.



REASSEMBLY

Assembly is reverse order of disassembly with special attention to the following steps.

CAUTION

If original components are not replaced, each piston, piston pin and conrod is to be assembled and installed in its original order and position.

PISTON TO CONROD

1. Apply engine oil to piston pin ②, piston pin bore and conrod ③.
2. Fit conrod ③ to piston ① as shown in figure and insert piston pin ② through piston and conrod.
3. Install piston pin circlips ④.

NOTE:

- Make sure conrod is installed in direction as shown in figure.
- Circlip should be installed with gap facing either up or down as shown in figure.

CAUTION

Do not re-use circlip once removed. Always use a new circlip.

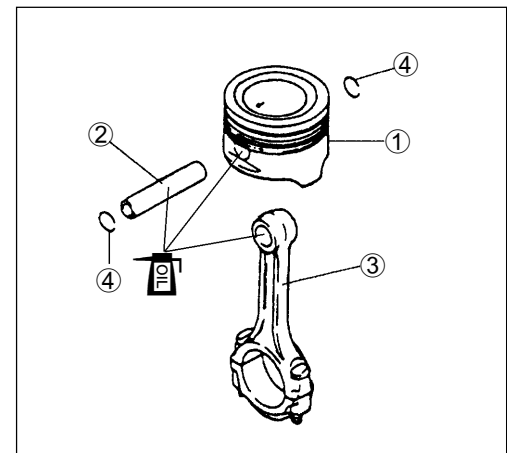
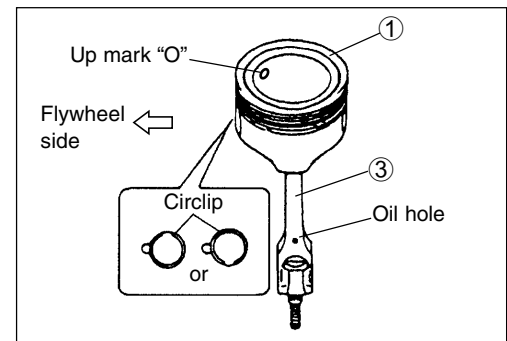

PISTON RING TO PISTON

Oil ring

1. Apply engine oil to piston rings.
2. Install spacer ① first, then side rails ② to piston.

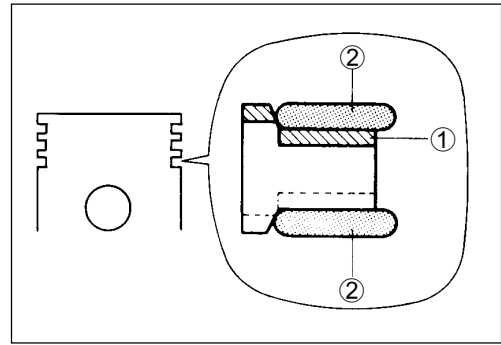

CAUTION

When installing spacer, do not allow ends to overlap in groove.

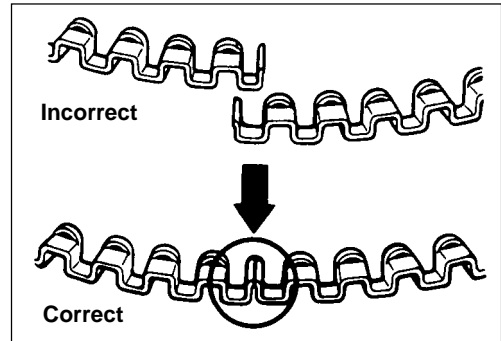

1st ring and 2nd ring

1. Apply engine oil to piston ring.
2. Install 2nd ring and 1st ring to piston.

NOTE:

- 1st ring differs from 2nd ring in shape and color of surface contacting cylinder wall.
Distinguish 1st ring from 2nd ring by referring to figure.
- As shown in figure, 1st and 2nd ring are marked, "RN" or "R".
When installing these piston rings, the marked side of each ring should face towards top of piston.

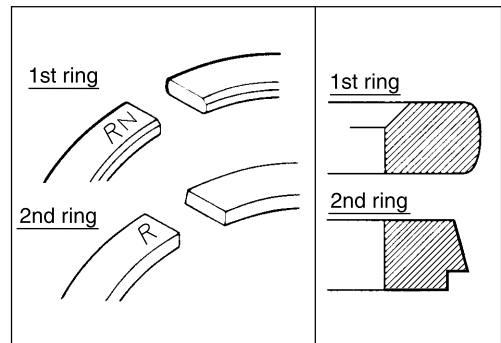
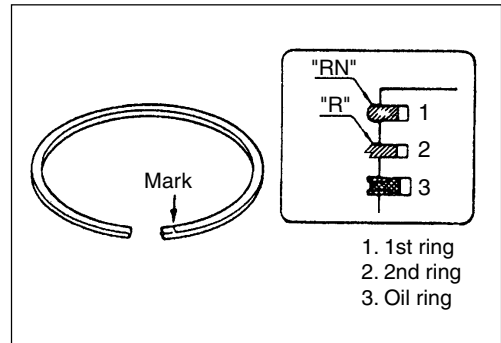

Ring gap direction

Position rings so that their gaps are staggered at approximately 90 degree angles as shown in figure.

- | | |
|----------------------------|----------------------------|
| ① 1st ring | ③ 2nd ring |
| ② Oil ring lower side rail | ④ Oil ring upper side rail |

CAUTION

Failure to stagger piston ring gaps may result in crank-case oil dilution.

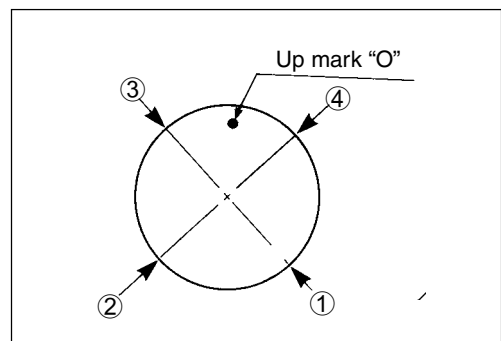

PISTON TO CYLINDER

1. Install conrod bearing to conrod and conrod cap.

CAUTION

- Assemble each conrod bearing to its original position.
- Do not apply oil between conrod and bearing or between conrod cap and bearing.

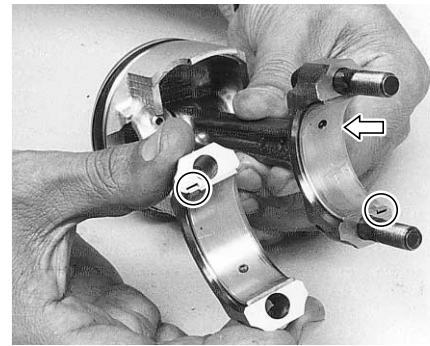

2. Apply engine oil to piston and cylinder walls.
3. Insert piston and conrod assembly into cylinder bore from cylinder head side using special tool.

 **09916-77310 : Piston ring compressor**

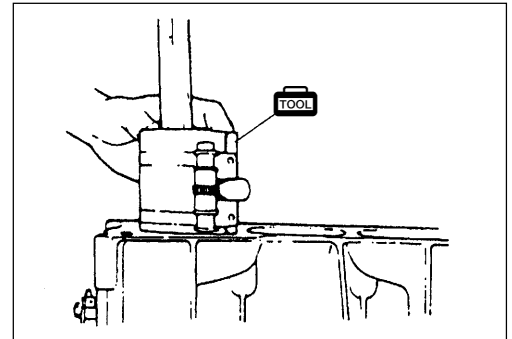
**NOTE:**

Position "circle" mark on piston head to flywheel side.

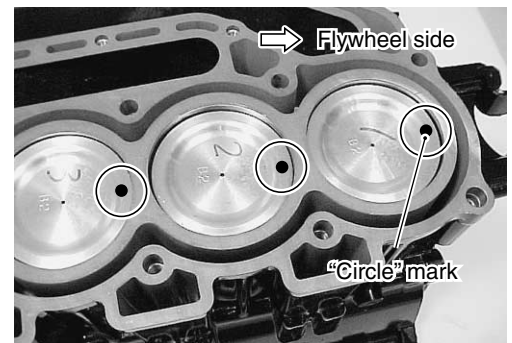

CRANKSHAFT TO CYLINDER

1. Install crankshaft main bearings in cylinder and crankcase.
2. Apply engine oil to bearings.

CAUTION

- Assemble each bearing to its original position.
- Assemble main bearing half containing oil groove / hole to cylinder block. Assemble the half without oil groove to crankcase.
- Do not apply oil between crank bearing holder and crank main bearing.

NOTE:

Align bearing tab **@** with notch in cylinder and crankcase.

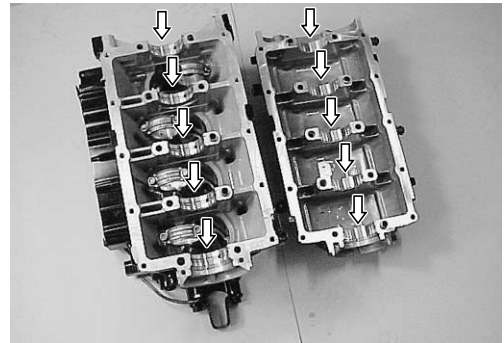

Thrust bearing

Apply engine oil to thrust bearing and install in cylinder block between the No.3 and No.4 cylinders.

Oil groove sides of thrust bearing should face towards crank webs.

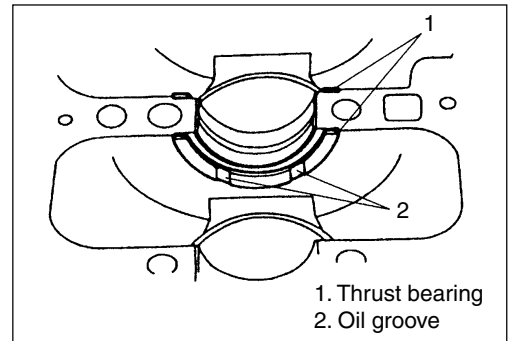

Crankshaft

1. Apply engine oil to upper oil seal lip.
2. Install upper oil seal to crankshaft.

CAUTION

Do not re-use oil seal once removed. Always use a new oil seal.

NOTE:

Install upper oil seal with its spring / lipped side facing inward.

3. Apply engine oil to crank pin and crankshaft main journal and install crankshaft in cylinder.

NOTE:

When installing crankshaft to cylinder, be sure to fit tab of seal in groove of cylinder.

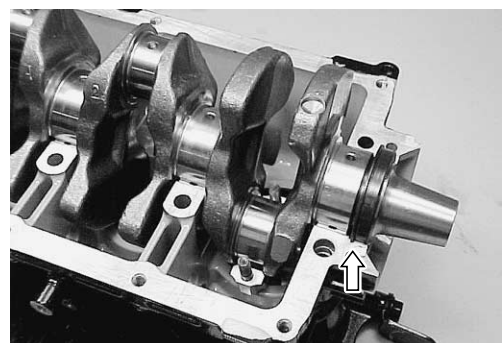
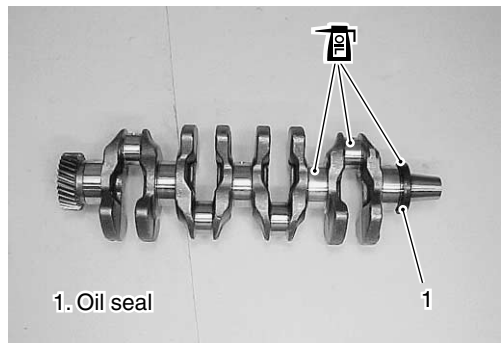

CONROD CAP

1. Apply engine oil to crank pin and conrod bearing.
2. Install conrod cap (with bearing) to conrod with dot (•) mark on cap toward flywheel side.

CAUTION

Reassemble each conrod cap to its original position.

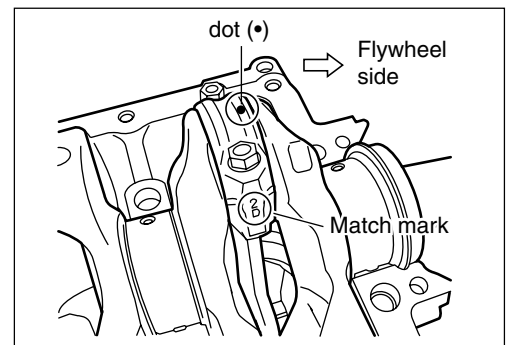

3. Apply engine oil lightly to conrod bolts.
4. Tighten conrod cap nuts in two steps.

Conrod cap nut :

1st step 18 N·m (1.8 kg-m, 13.0 lb.-ft.)

Final step 35 N·m (3.5 kg-m, 25.5 lb.-ft.)

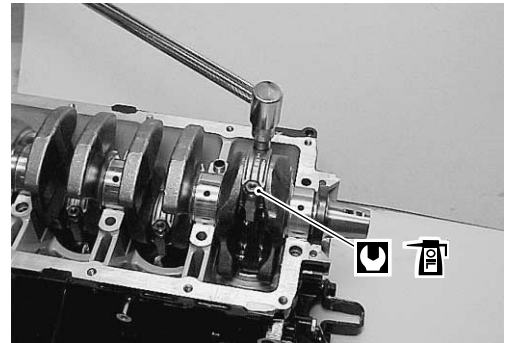
**CRANKCASE TO CYLINDER**

1. Clean mating surface of cylinder and crankcase.
2. Apply Suzuki Bond to mating surface of crankcase as shown in figure.

1104 99000-31030 : Suzuki Bond No.1104

CAUTION

Apply bond to mating surface only.
Do not allow bond to contact surface of bearing.

Apply Bond to ■ marked line.

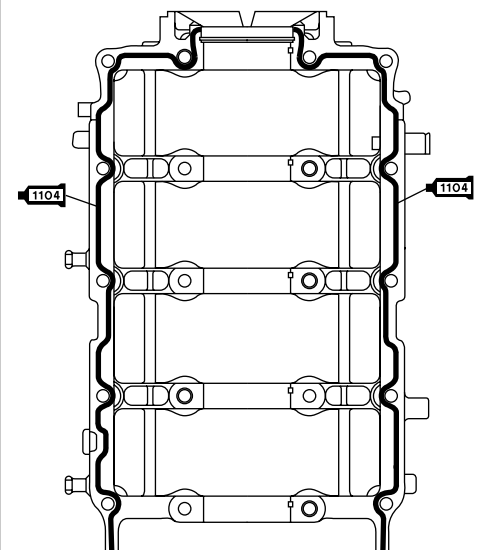

3. Install five (5) dowel pins ①.

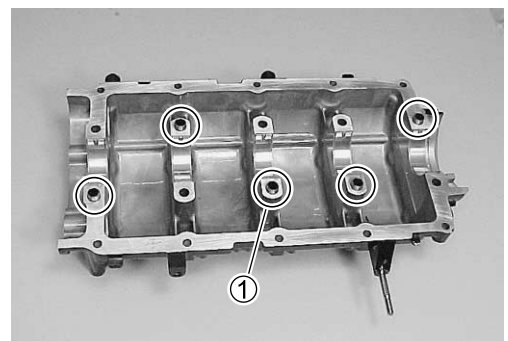

6-62 POWER UNIT

4. Install crankcase to cylinder.
5. Apply engine oil lightly to crankcase bolts.
6. Tighten crankcase bolts in three (3) steps according to the order shown below and in figure.

NOTE:

After tightening crankcase bolts, check to be sure that crankshaft rotates smoothly when turned by hand.

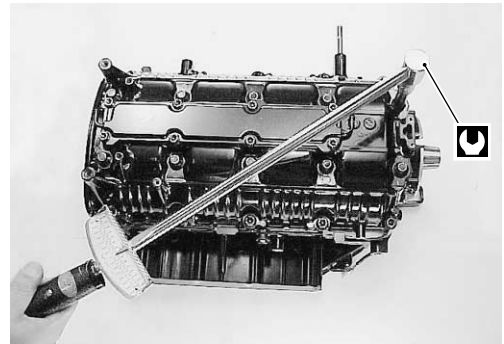

Crankcase bolt :

1st step	8 mm	5 N·m (0.5 kg-m, 3.5 lb.-ft.)
	10 mm	11 N·m (1.1 kg-m, 8.0 lb.-ft.)
2nd step	8 mm	20 N·m (2.0 kg-m, 14.5 lb.-ft.)
	10 mm	43 N·m (4.3 kg-m, 31.0 lb.-ft.)
Final step	8 mm	25 N·m (2.5 kg-m, 18.0 lb.-ft.)
	10 mm	56 N·m (5.6 kg-m, 40.5 lb.-ft.)

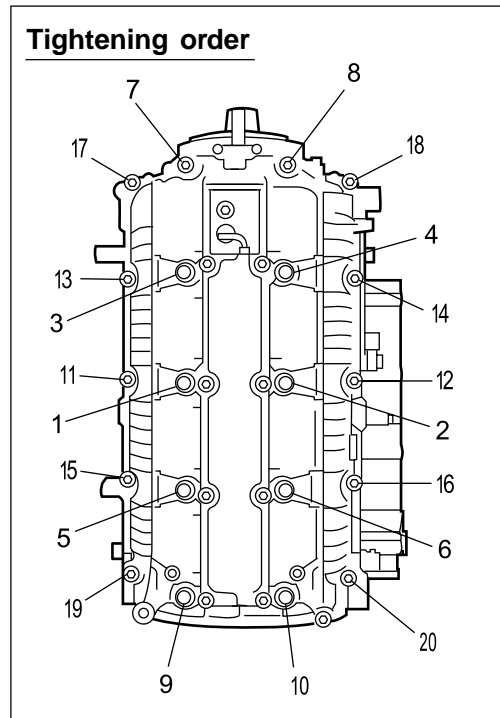

CYLINDER HEAD

Install cylinder head. (See page 6-21 to 6-23)

OIL PUMP

Install oil pump assembly. (See page 6-13)

TIMING CHAIN

Install timing chain. (See page 6-17 to 6-19)

POWER UNIT

Install power unit. (See page 6-9 to 6-11)

THERMOSTAT

REMOVAL

1. Disconnect water hose ① from thermostat cover.
2. Remove the three (3) bolts ② securing the thermostat cover, then remove the cover ③ and thermostat ④.

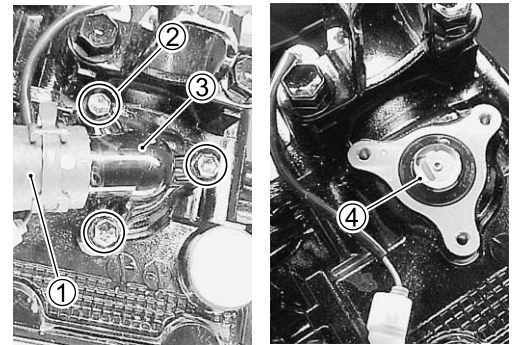

INSPECTION

Inspect thermostat for salt deposits, corrosion, wear or other damage.

Clean or replace if necessary.



Thermostat operation

Check thermostat opening temperature as follows :

1. Insert a length of thread between thermostat valve / body and suspend thermostat in a container filled with water.
2. Place thermometer in container and heat water. Observe water temperature when thermostat valve opens and releases thread.

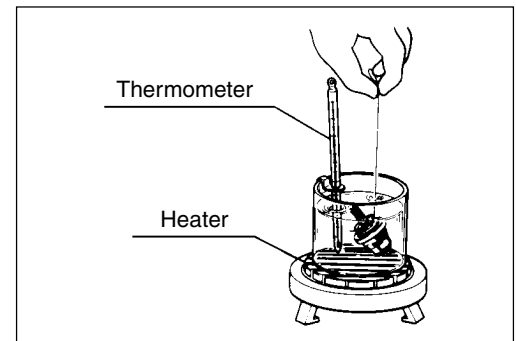

Thermostat operating temperature :
Standard : 58 – 62 °C (136 – 144 °F)

INSTALLATION

Installation is reverse order of removal with special attention to the following steps.

- Assemble thermostat ① and thermostat cover ② to cylinder head block and secure with bolts.

 **Thermostat cover bolt : 10 N-m (1.0 kg-m, 7.0 lb.-ft.)**

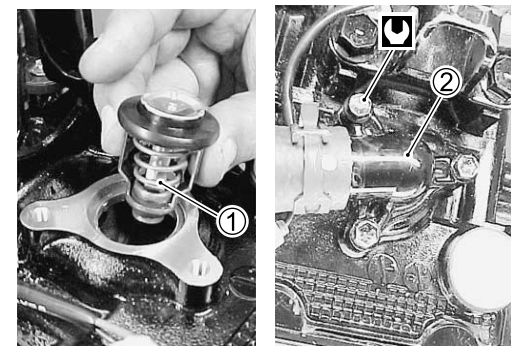

OPERATION

WATER COOLING SYSTEM

The water cooling system includes the lower unit water pump, lower unit to power unit water supply tube, oil pan water pressure valve, power unit water passages and thermostat.

This system cools both the power unit and exhaust and is shown in schematic from below.

If overheating occurs, the components of the cooling system must be inspected for blockage, corrosion build-up or component damage.

<u>Component inspection</u>	<u>Refer to page</u>
Water pump / Impeller	9-11
Water tube	7-6
Thermostat	6-63
Water pressure valve	7-20
Cylinder head	6-26
Cylinder block	6-43

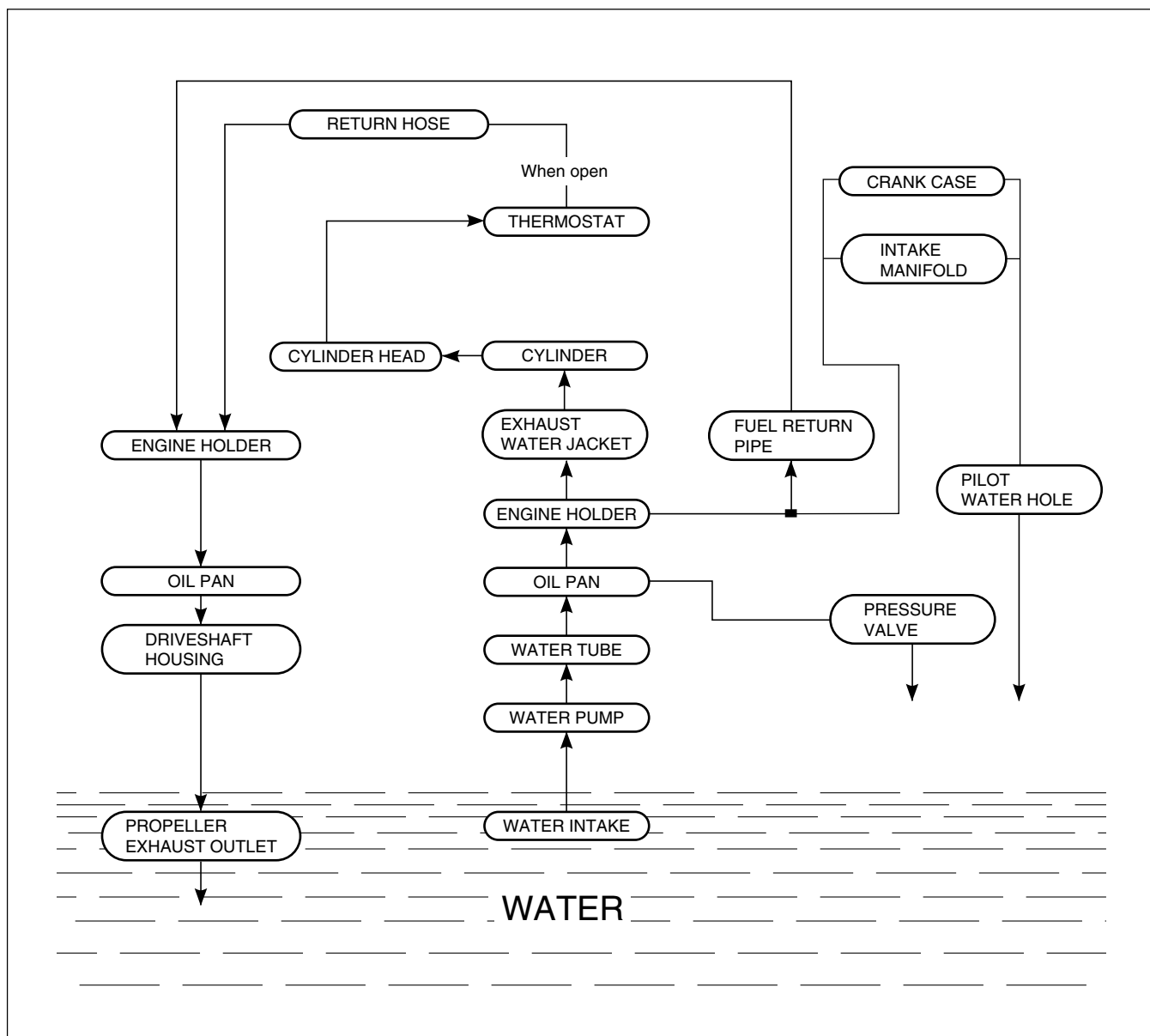

ENGINE LUBRICATION SYSTEM

A camshaft driven trochoid type pump provides engine oil to all power unit components requiring lubrication. Oil from the oil pan is drawn through the oil strainer and passed through a spin-on type oil filter before entering the main oil gallery.

A pressure regulator (relief valve) is positioned between the oil pump and oil filter to maintain oil pressure at a constant level.

From the main gallery, oil flow is directed through either drilled internal passages or by splash method to those surfaces requiring lubrication.

ENGINE OIL LUBRICATION CHART

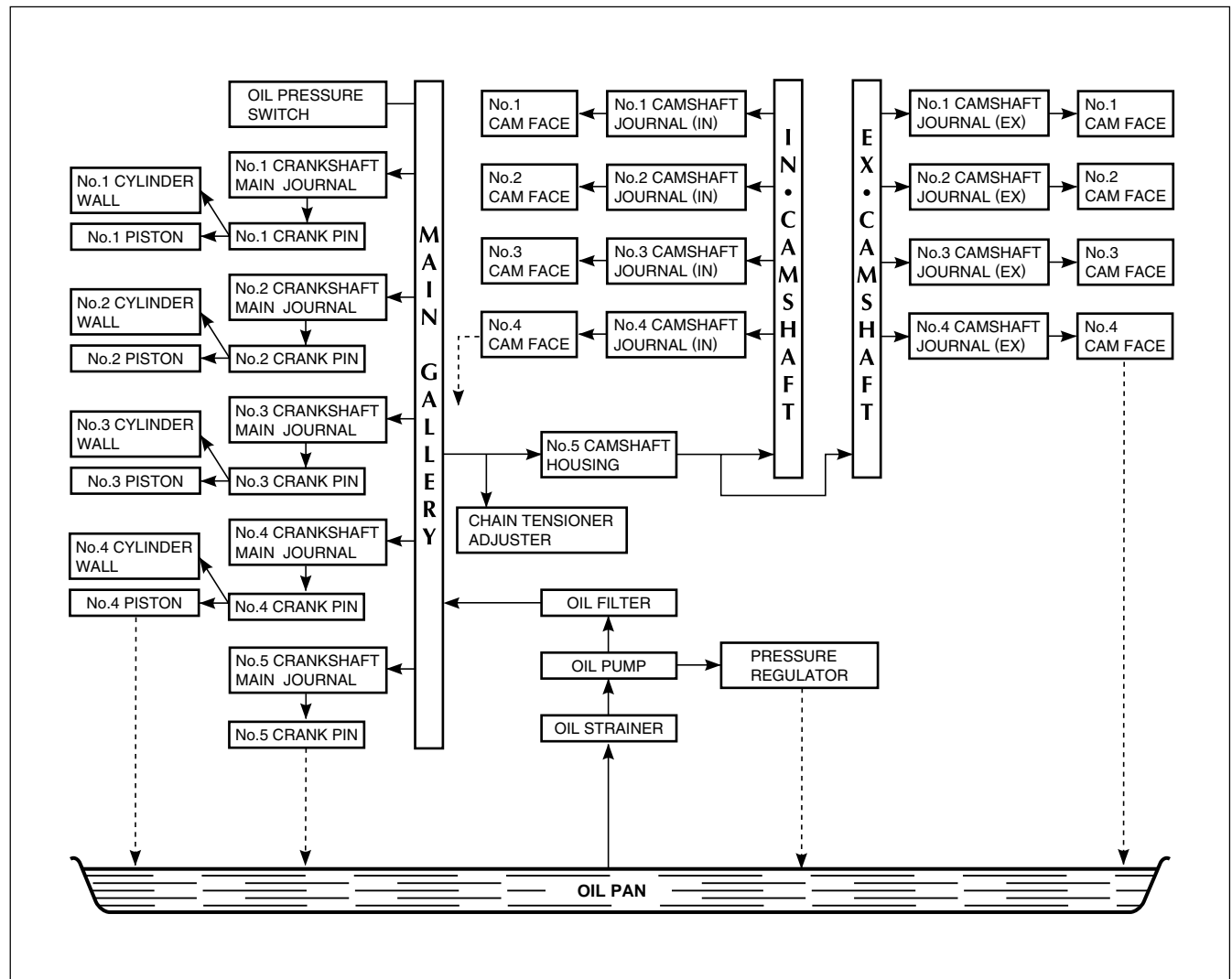

MID UNIT**CONTENTS**

ENGINE SIDE COVER _____	7-2
REMOVAL	7-2
INSTALLATION	7-2
DRIVESHAFT HOUSING AND OIL PAN _____	7-3
REMOVAL	7-3
INSPECTION	7-5
ASSEMBLY	7-7
SWIVEL BRACKET, STEERING BRACKET AND CLAMP BRACKET _____	7-13
REMOVAL	7-13
INSPECTION	7-15
REASSEMBLY	7-16
WATER PRESSURE VALVE _____	7-20
REMOVAL / INSPECTION / INSTALLATION	7-20

ENGINE SIDE COVER REMOVAL

1. Remove side cover seal ①.

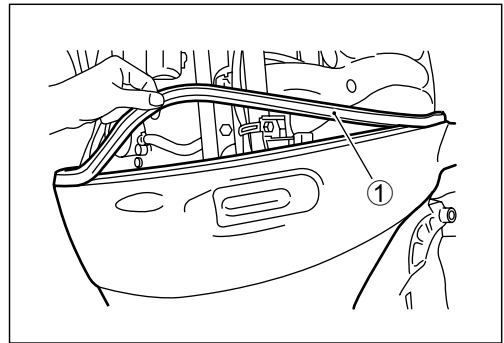

2. Remove seven screws ② and STBD side cover ③.

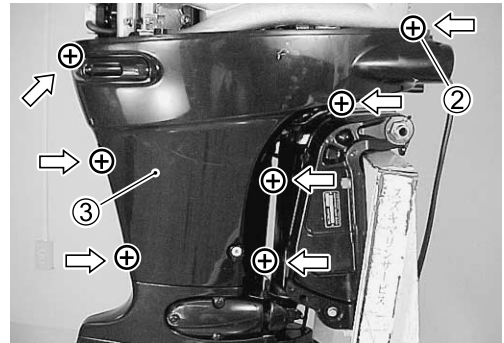

3. Remove two screws ④ and PORT side cover ⑤.

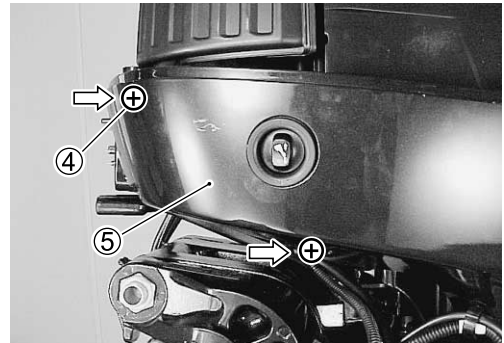

4. Disconnect PTT switch lead connector.

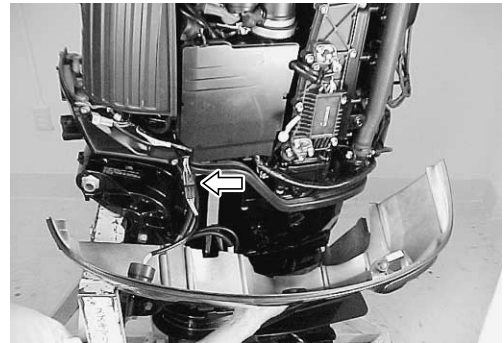

INSTALLATION

Installation is reverse order of removal.

DRIVESHAFT HOUSING AND OIL PAN REMOVAL

1. Remove power unit. (See pages 6-5 to 6-8)
2. Remove lower unit. (See page 9-2)
3. Disconnect water hose ① and ②.
4. Remove screw and bonding wire from driveshaft housing.
5. Remove the clutch rod ③.
6. Remove lower mount cover bolts ④ and PORT/STBD lower mount covers ⑤.
7. Remove STBD / PORT lower mount nuts ⑥ and lower mount bolts ⑦.
8. Remove lower mount assembly ⑧.

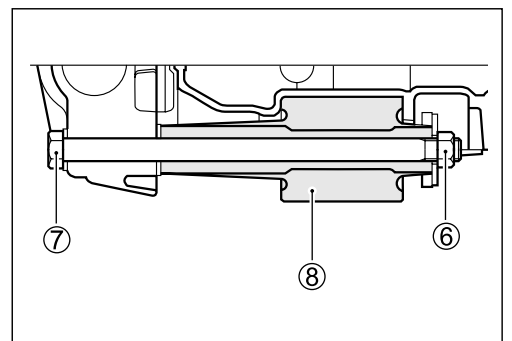
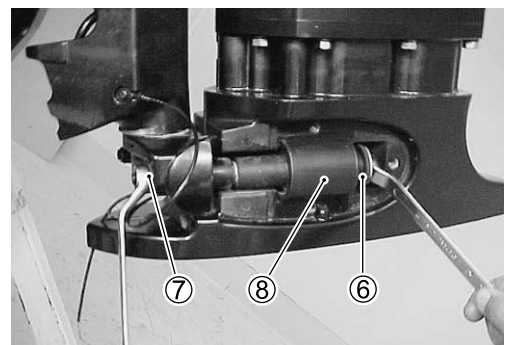
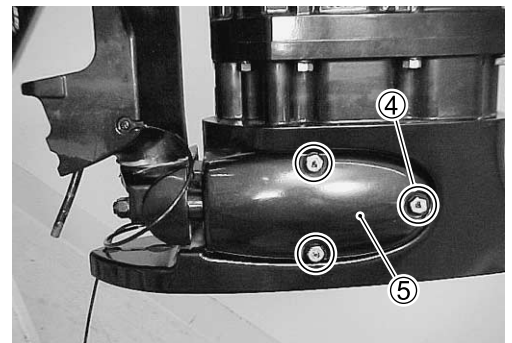
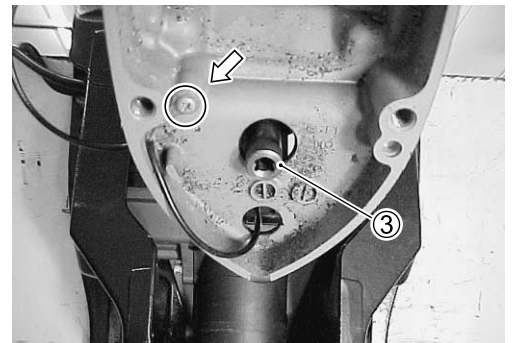
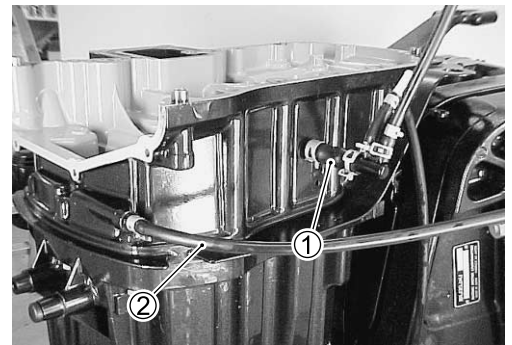

7-4 MID UNIT

9. Remove two upper mount nuts ⑨ and washers.

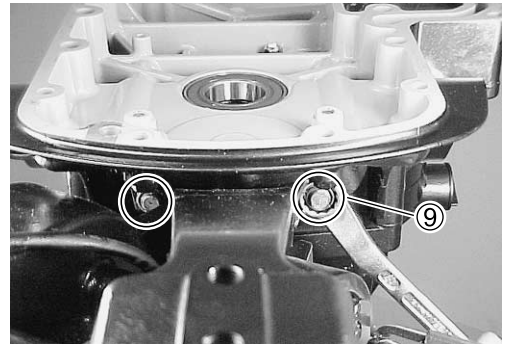

10. Remove driveshaft housing with oil pan.

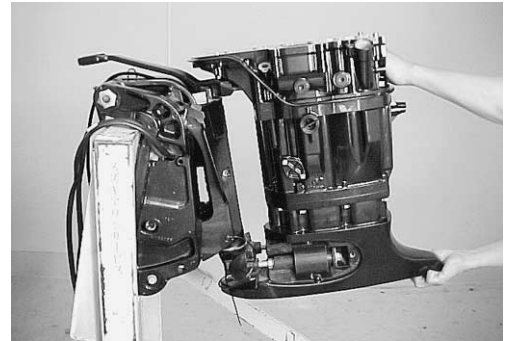

11. Remove two bolts ⑩ and clutch shaft holder ⑪.

12. Remove four bolts ⑫ and upper mount cover ⑬.

13. Remove upper mount assembly ⑭.

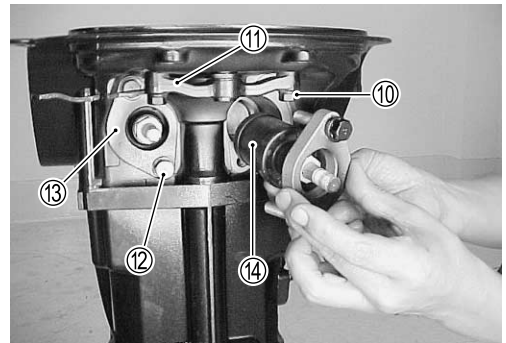

14. Remove four bolts ⑮ and engine holder ⑯.

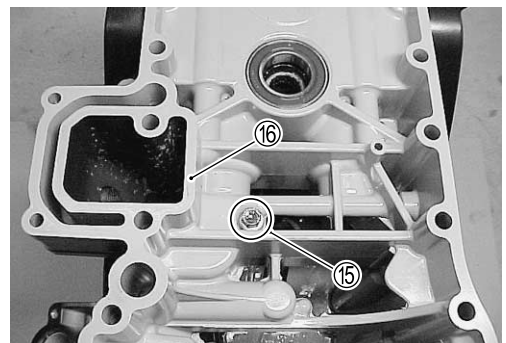
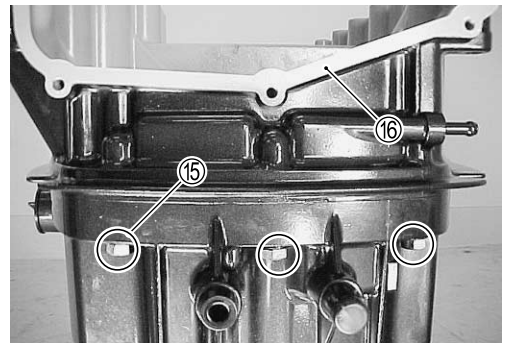

15. Remove three bolts ⑰ and oil strainer ⑱.

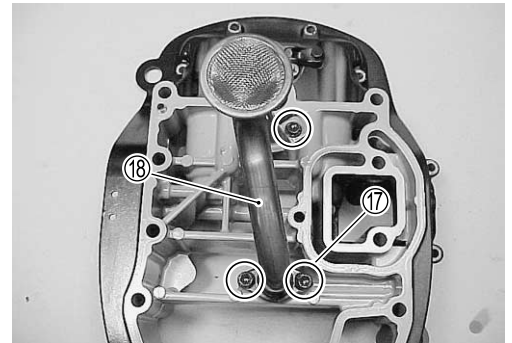

16. Remove eight bolts ⑲ and oil pan ⑳.



17. Remove water tube ㉑.

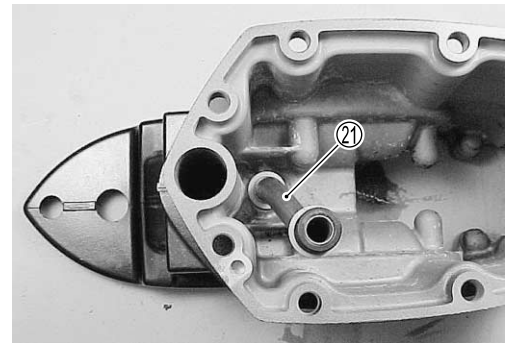

INSPECTION

NOTE:

If excessive wear, cracks, defective or other damage is found on any component, replace component.

Mid unit component

Inspect oil pan, driveshaft housing, engine holder and mount covers for cracks, defects or other damage.

Replace if necessary.

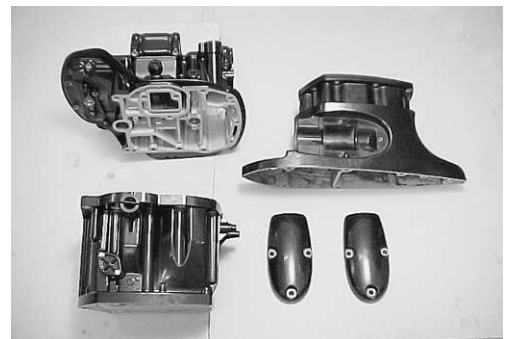

Mount

Inspect upper and lower mount for excessive wear, corrosion or other damage.
Replace if necessary.

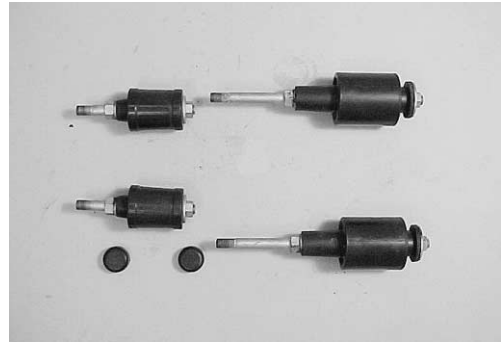

Water tube

Inspect water tube for clog, obstruction, crack, corrosion or other damage.
Clean or replace if necessary.



Inspect water tube grommet for excessive wear or other damage.
Replace if necessary.

Counter shaft bearing

Inspect counter shaft bearing for pitting, rough or other damage.
Replace if necessary.

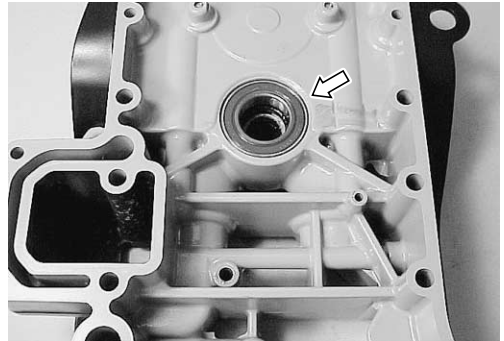

Oil seal

Inspect driveshaft upper and counter shaft oil seal for leakage, crack, cut or other damage.
Replace if necessary.

NOTE:

Install oil seal with lip (spring side) facing as shown in figure.

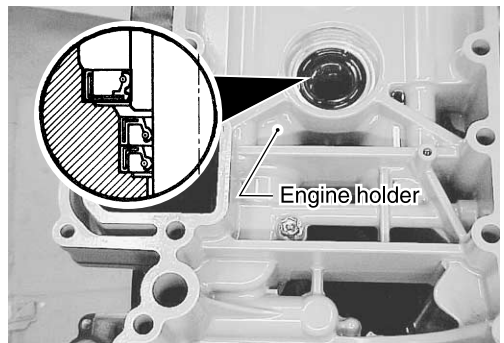

ASSEMBLY

Assembly is reverse order of removal with special attention to the following steps.

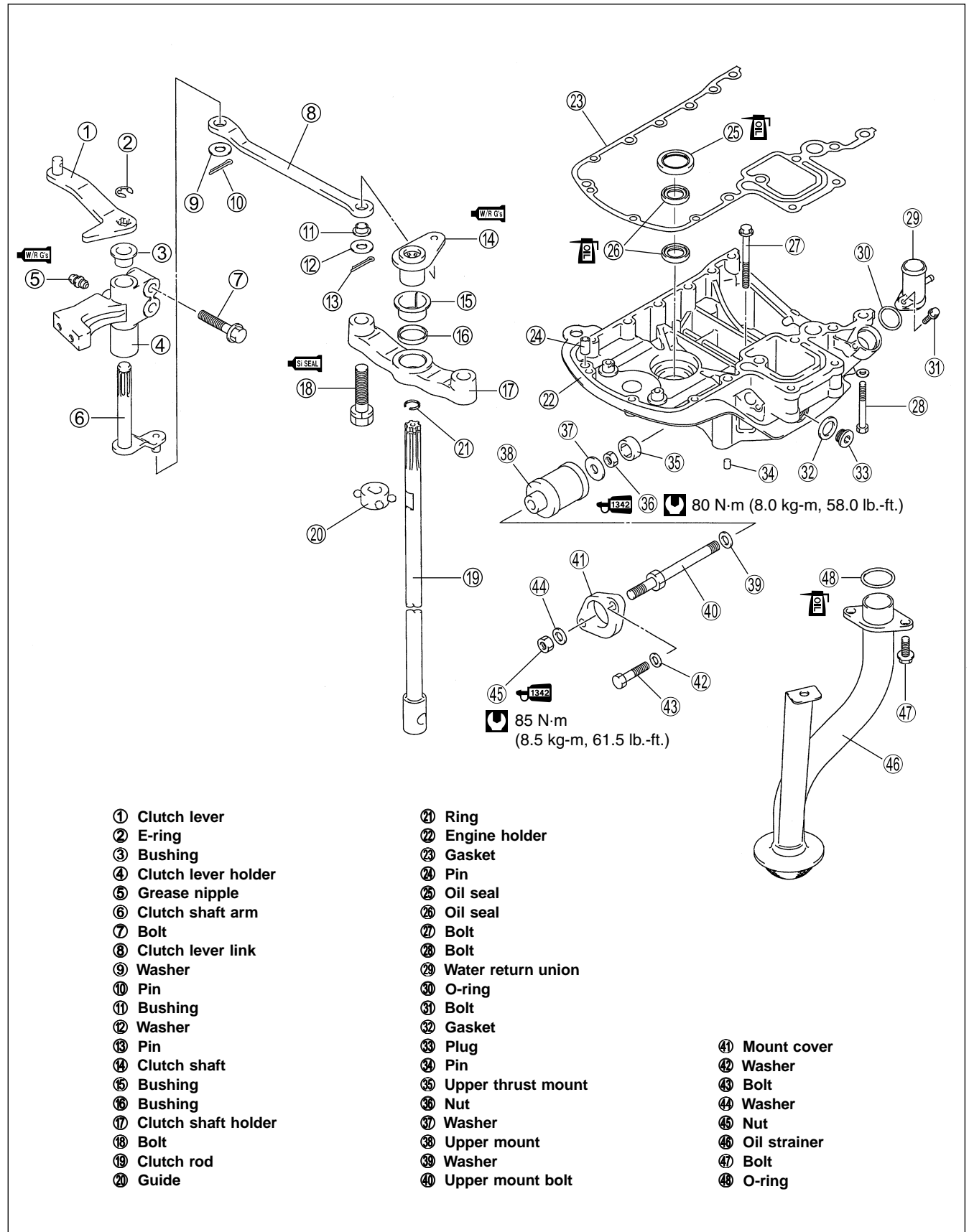

- ① Clutch lever
- ② E-ring
- ③ Bushing
- ④ Clutch lever holder
- ⑤ Grease nipple
- ⑥ Clutch shaft arm
- ⑦ Bolt
- ⑧ Clutch lever link
- ⑨ Washer
- ⑩ Pin
- ⑪ Bushing
- ⑫ Washer
- ⑬ Pin
- ⑭ Clutch shaft
- ⑮ Bushing
- ⑯ Clutch shaft holder
- ⑰ Bolt
- ⑱ Clutch rod
- ⑳ Guide

- ㉑ Ring
- ㉒ Engine holder
- ㉓ Gasket
- ㉔ Pin
- ㉕ Oil seal
- ㉖ Oil seal
- ㉗ Bolt
- ㉘ Bolt
- ㉙ Water return union
- ㉚ O-ring
- ㉛ Bolt
- ㉜ Gasket
- ㉝ Plug
- ㉞ Pin
- ㉟ Upper thrust mount
- ㊱ Nut
- ㊲ Washer
- ㊳ Upper mount
- ㊴ Washer
- ㊵ Upper mount bolt

- ㊶ Mount cover
- ㊷ Washer
- ㊸ Bolt
- ㊹ Washer
- ㊺ Nut
- ㊻ Oil strainer
- ㊼ Bolt
- ㊽ O-ring

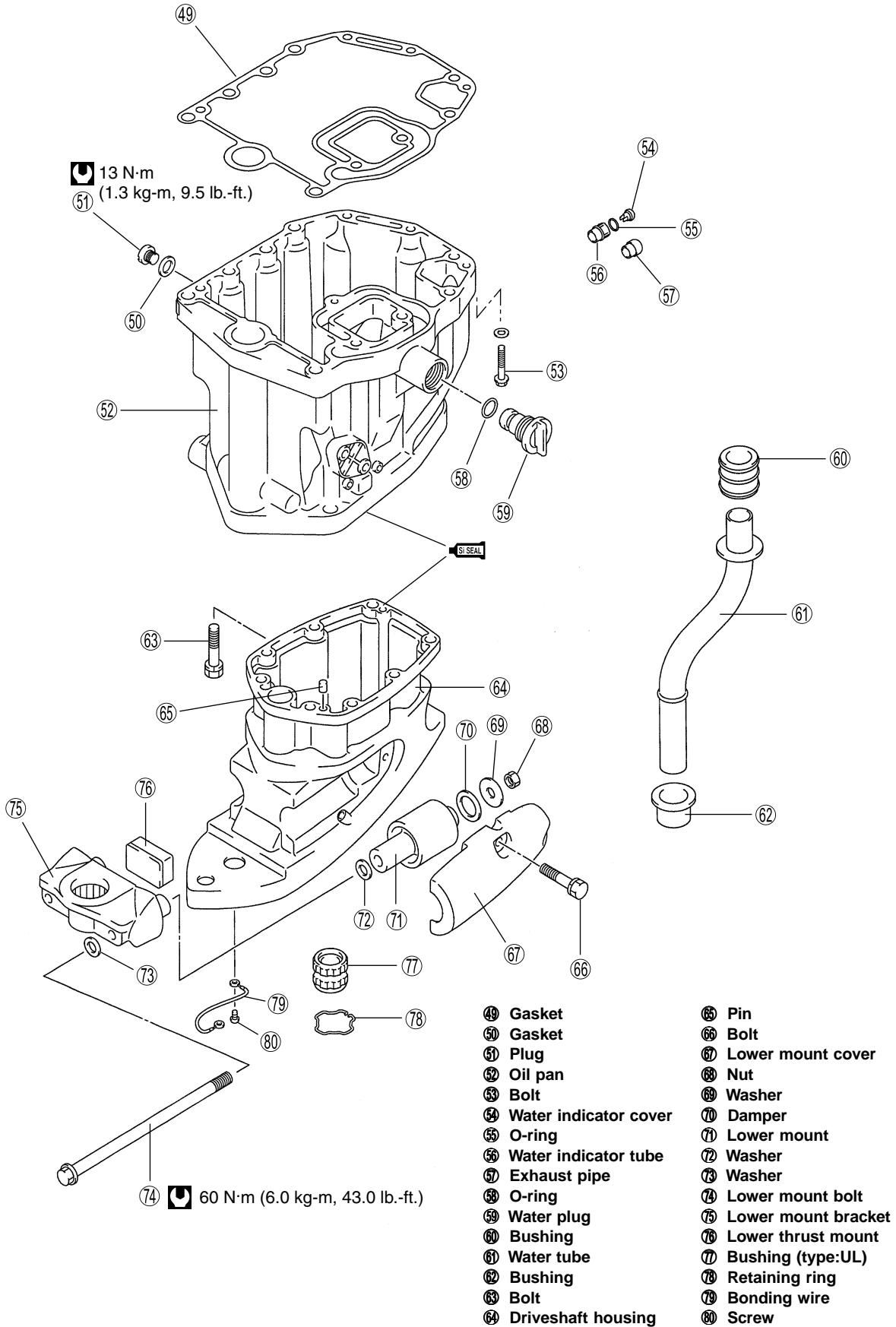

OIL PAN TO DRIVESHAFT HOUSING

1. Install water tube ①.
2. Install two dowel pins ② to driveshaft housing ③.
3. Apply sealant to mating surfaces of driveshaft housing and oil pan.

 99000-31120 : Suzuki Silicone Seal

4. Install oil pan ④ to driveshaft housing, then tighten eight bolts ⑤ securely.

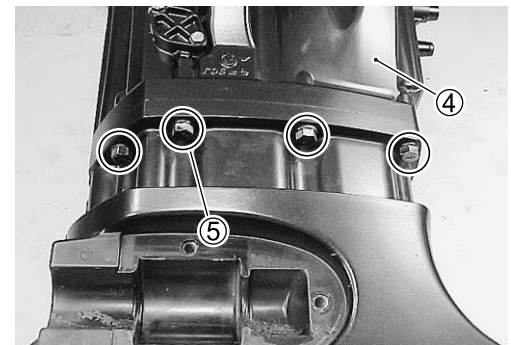
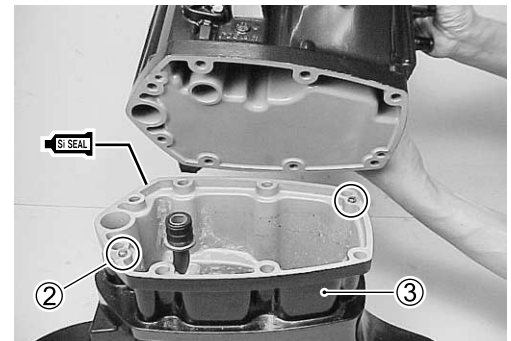
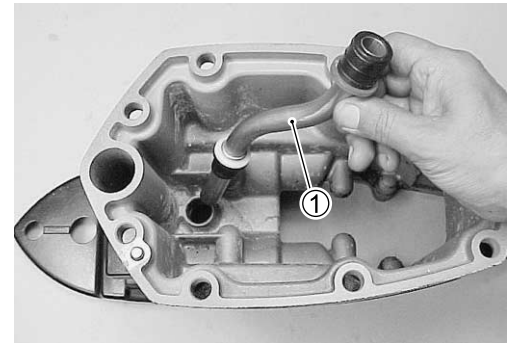
**ENGINE HOLDER TO OIL PAN**

1. Apply engine oil to O-ring ①, then install O-ring to oil strainer ②.
2. Install oil strainer to engine holder, then tighten bolts securely.

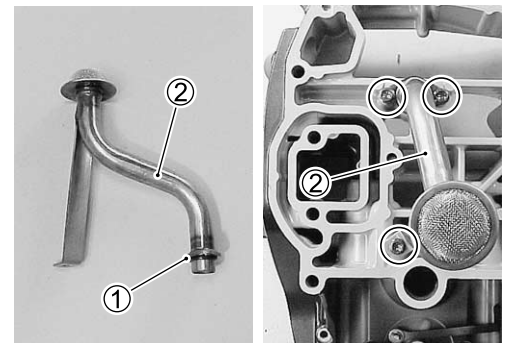

3. Install two (2) dowel pins ③ and gasket ④ to oil pan.

CAUTION

Do not re-use gasket and O-ring once removed. Always use new parts.



4. Install engine holder ⑤ to oil pan, then securely tighten it with four bolts ⑥.

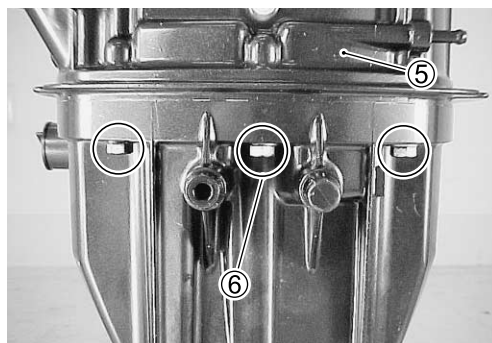
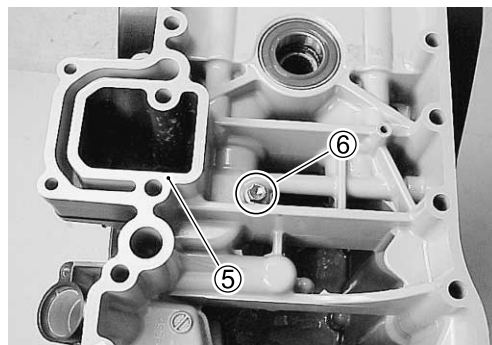

UPPER MOUNT

Upper mount and mount cover

1. Place washer ①, upper mount ② and washer ③ on upper mount bolt ④.
2. Tighten upper mount rear nut ⑤, pre-coated with thread lock, to specified torque.

 99000-32050 : Thread Lock "1342"

 Upper mount rear nut :

80 N·m (8.0 kg·m, 58.0 lb.-ft.)

3. Install thrust mount ⑥ to upper mount rear nut, then place upper mount into engine holder.
4. Install upper mount covers ⑦, then tighten bolts ⑧, pre-coated with thread lock, to specified torque.

NOTE:

Before tightening mount cover bolts, be sure upper mount bolt head is positioned as shown in figure.

 99000-32050 : Thread Lock "1342"

 Upper mount cover plate bolt :

50 N·m (5.0 kg·m, 36.0 lb.-ft.)

5. Install clutch shaft holder ⑨ to engine holder, then tighten bolts ⑩, pre-coated with silicone seal, to securely.

 99000-31120 : Suzuki silicone seal

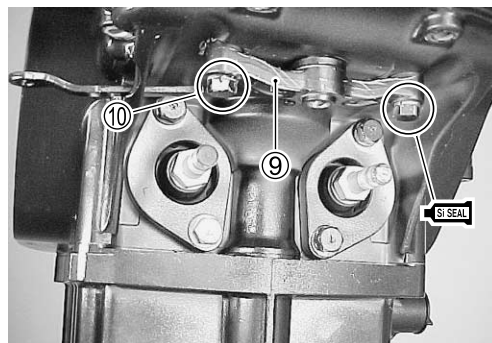
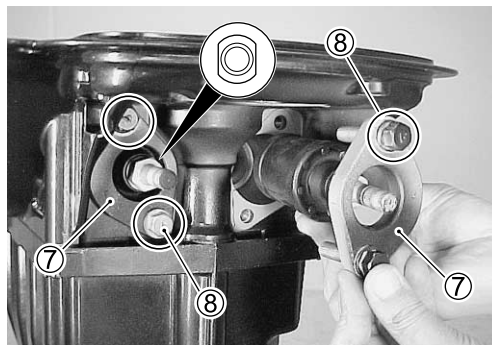
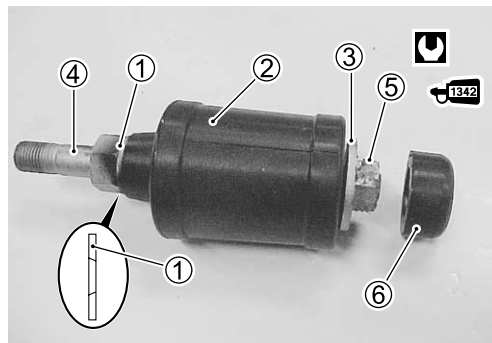

DRIVESHAFT HOUSING / OIL PAN

1. Install driveshaft housing / oil pan to steering bracket.

NOTE:

Be sure upper mount bolt head properly fits into the steering bracket groove when installing driveshaft housing / oil pan assembly.

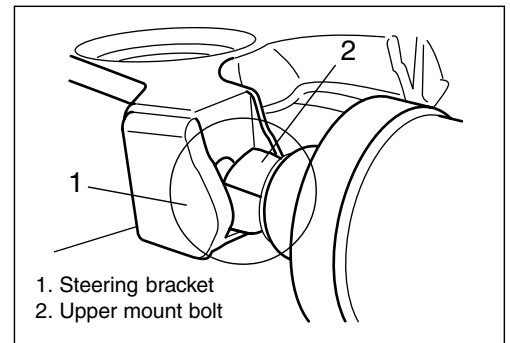

2. Install washer ① and upper mount front nut ②, then tighten two nuts, pre-coated with thread lock, to specified torque.

 **Upper mount front nut : 85 N·m (8.5 kg-m, 61.5 lb.-ft)**

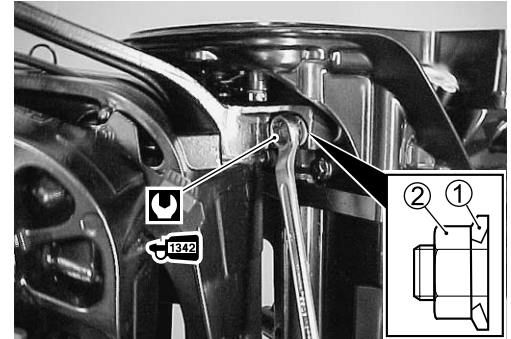
**LOWER MOUNT / MOUNT BOLT**

1. Place washer ①, damper ②, lower mount ③ and washer ④ into driveshaft housing.
2. Install lower mount bolt ⑤ and washer ⑥, then tighten mount bolt with lock nut ⑦ to specified torque.

 **Lower mount bolt / nut :**
60 N·m (6.0 kg-m, 43.0 lb.-ft.)

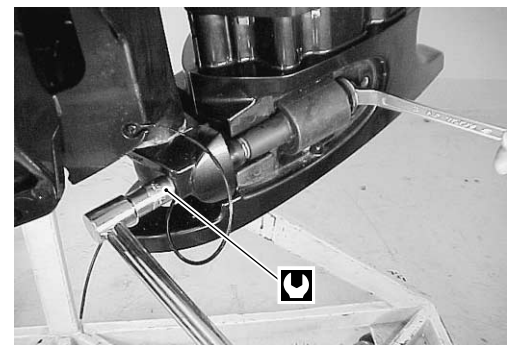
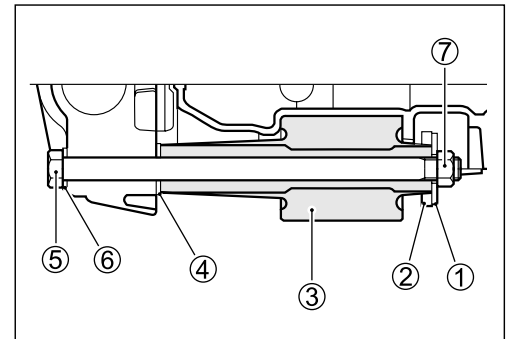

3. Install lower mount covers to driveshaft housing, then tighten lower mount cover bolts securely.

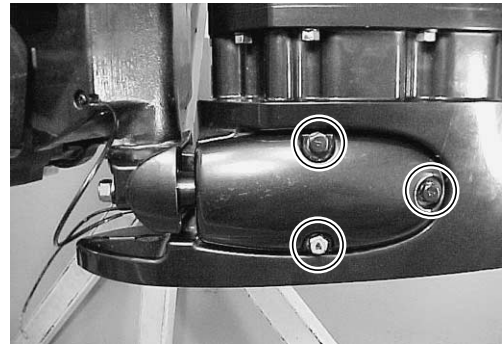

BONDING WIRE

Reattach bonding wire to driveshaft housing and tighten screw securely.

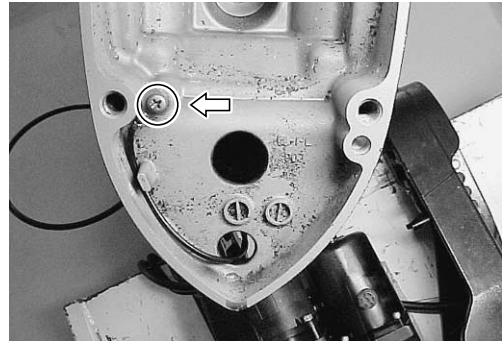

POWER UNIT

1. Install power unit. (See page 6-9 to 6-11)
2. Tighten power unit mounting bolts and engine holder bolts to specified torque.

-  **Power unit mounting bolt & Engine holder bolt :**
- | | |
|-------|---------------------------------|
| 8 mm | 23 N·m (2.3 kg-m, 16.5 lb.-ft.) |
| 10 mm | 50 N·m (5.0 kg-m, 36.0 lb.-ft.) |

SWIVEL BRACKET, STEERING BRACKET AND CLAMP BRACKET

REMOVAL

1. Remove driveshaft housing / oil pan.
(See page 7-3)
2. Remove screw and bonding wire from lower mount bracket.
3. Remove circlip ①.
4. Remove lower mount bracket ②, shim ③, and washer ④ from the steering shaft.
5. Lift steering bracket ⑤ upward to remove from swivel bracket.
6. Remove washer ⑥ and upper bushing ⑦.
7. Remove swivel bracket seal ⑧ and lower bushing ⑨.
8. Remove circlip ⑩ and push out tilt cylinder upper rod ⑪.

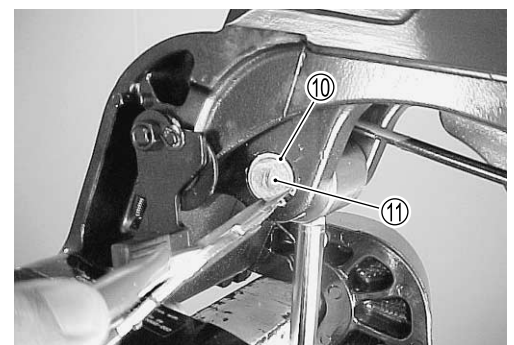
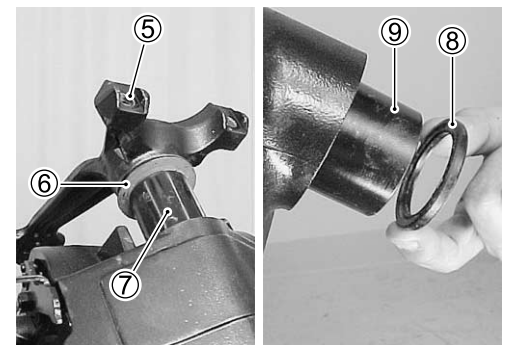
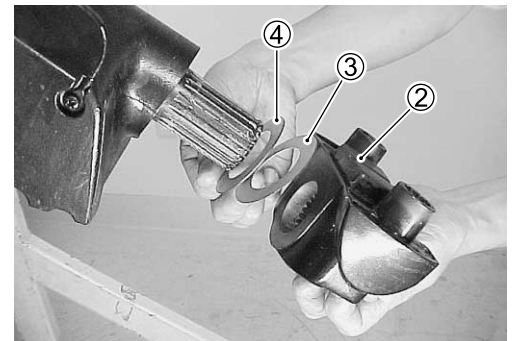

7-14 MID UNIT

9. Remove tilt cylinder lower shaft bolts ⑫.

10. Remove bolts and anode ⑬.

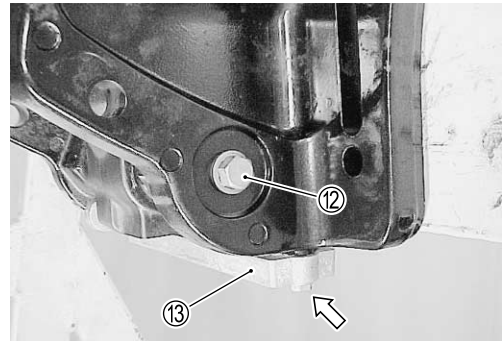
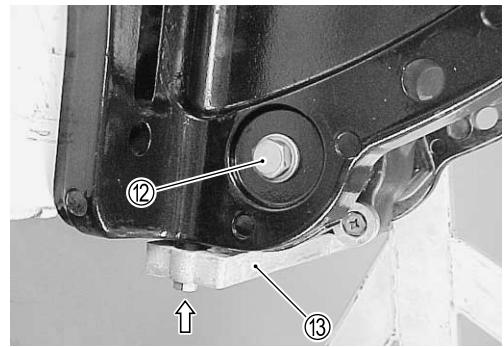

11. Remove STBD motor mounting bolts ⑭.

12. Remove clamp bracket shaft nut ⑮.

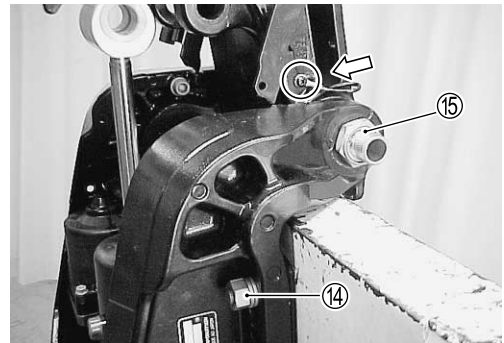

13. Slide STBD clamp bracket ⑯ off clamp bracket shaft, then remove screw and bonding wire from swivel bracket.

14. Remove PTT unit with lower rod.

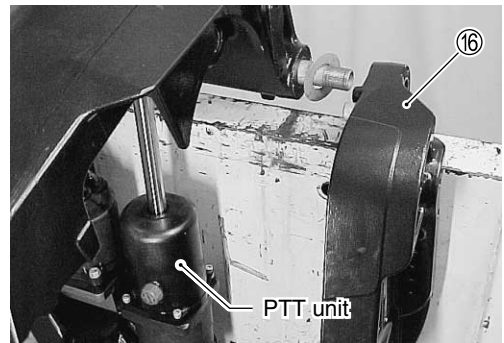

15. Pull PORT clamp bracket ⑰ outward to remove clamp bracket and bracket shaft ⑱ from swivel bracket ⑲.

16. Remove washer ⑳ and bushing ㉑ from each side of swivel bracket.

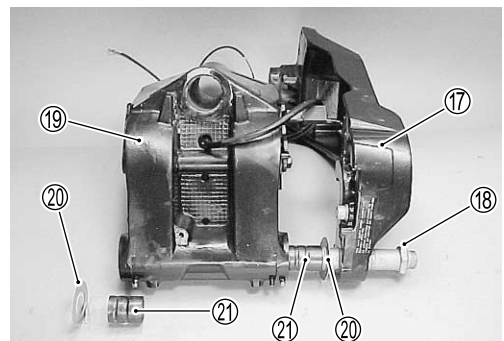

INSPECTION

NOTE:

If excessive wear, cracks, defective or damage is found on any component, replace component.

BUSHINGS

Inspect all bushings for excessive wear or other damage.

Replace if necessary.

If bushing fit is loose when installing, replace bushing.



OIL SEAL

Inspect swivel bracket seal for cuts, nicks, excessive wear or other damage.



CLAMP BRACKET SHAFT

Inspect clamp bracket shaft for bend, twist or other damage.

Replace if necessary.



BRACKET

Inspect clamp brackets, steering bracket and swivel bracket for excessive wear, cracks or other damage.

Replace if necessary.

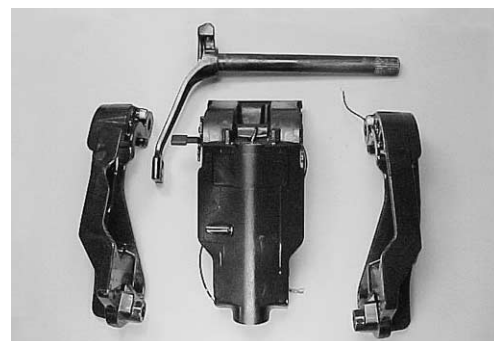

REASSEMBLY

Reassembly is reverse order of removal with special attention to the following steps.

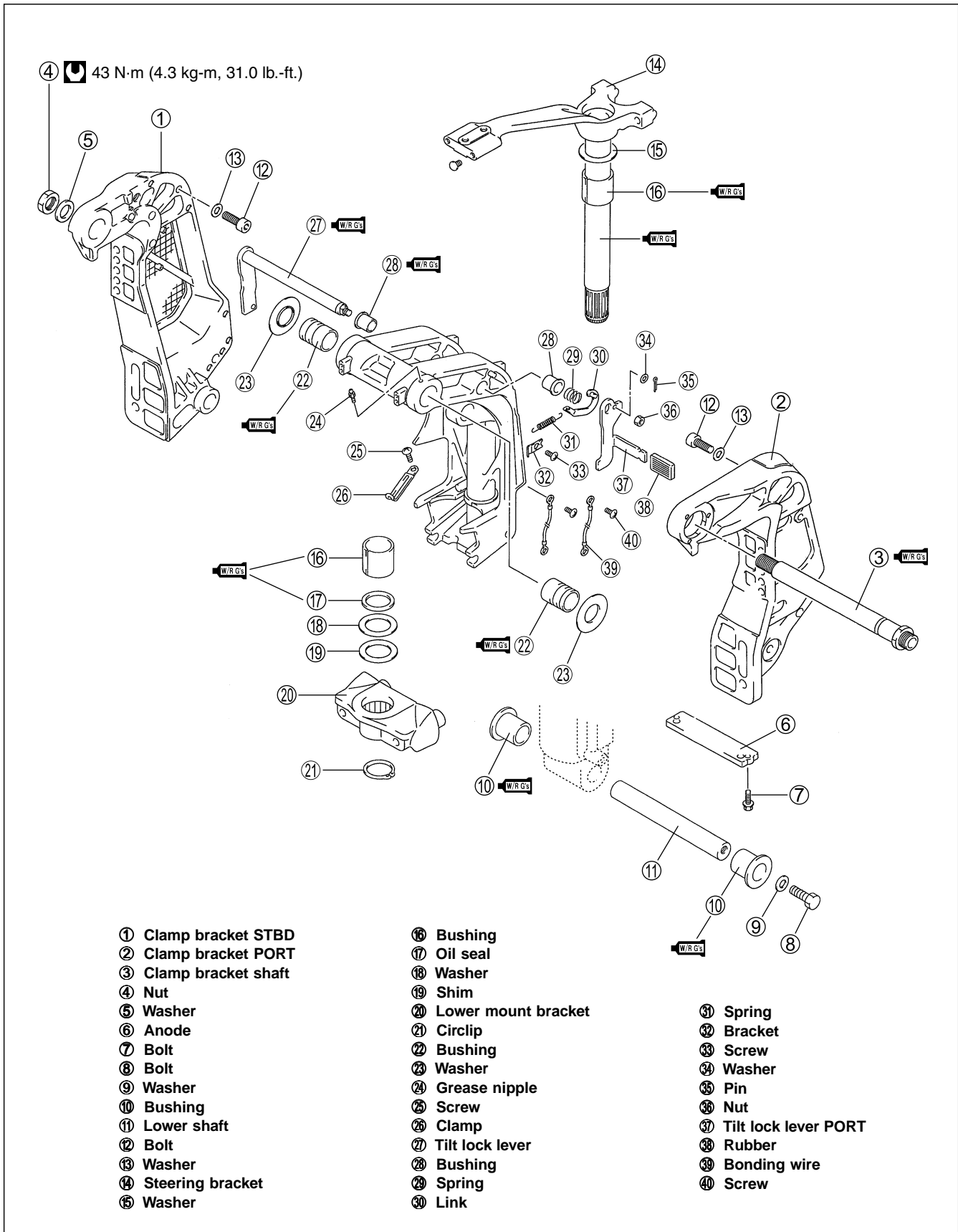

CLAMP BRACKET AND SWIVEL BRACKET

NOTE:

Before installing clamp bracket to swivel bracket, apply grease to clamp bracket shaft and bushings.

99000-25160 : Suzuki Water Resistant Grease

1. Insert PORT and STBD bushings ② into swivel bracket ①.
2. Assemble port clamp bracket ③, washer ④, clamp bracket shaft ⑤ and swivel bracket ①.
3. Install PTT unit assembly ⑥, lower shaft and bushings in position.
(For PTT unit assembly installation, see page 8-15 to 8-16)

4. Install washer ⑦, STBD clamp bracket ⑧ and clamp bracket shaft nut ⑨, then tighten clamp bracket shaft nut to specified torque.

Clamp bracket shaft nut :

43 N·m (4.3 kg-m, 31.0 lb.-ft.)

5. Tighten lower shaft bolts ⑩, pre-coated with thread lock, to specified torque.

99000-32050 : Thread lock 1342

Cylinder lower shaft bolt :

50 N·m (5.0 kg-m, 36.0 lb.-ft.)

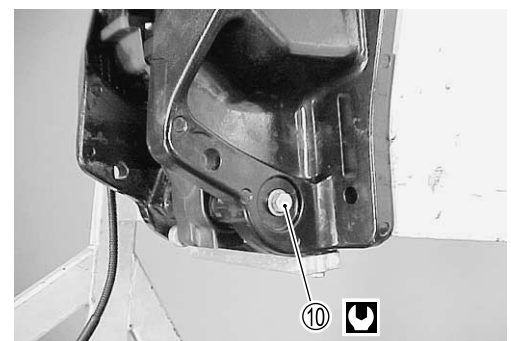
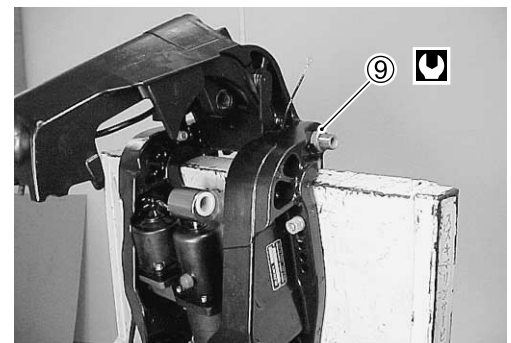
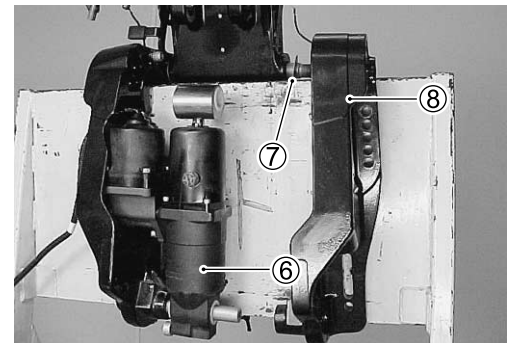
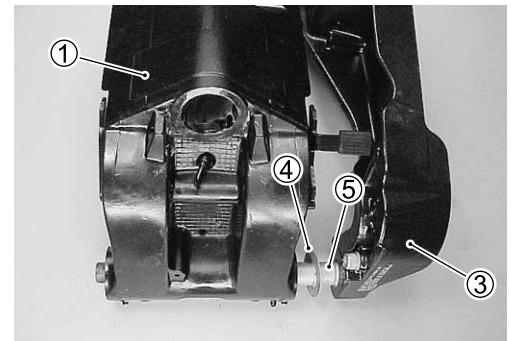
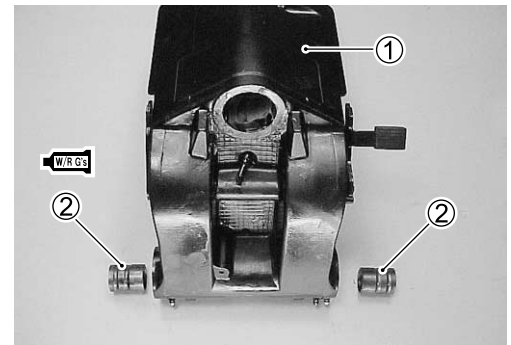

STEERING BRACKET

1. Apply Water Resistant Grease to steering bracket shaft.

 **99000-25160 : Suzuki Water Resistant Grease**

NOTE:

Apply grease to bushings, oil seal lip and pilot shaft portion of steering bracket.

2. Install upper bushing ①, and washer ② to swivel bracket.
3. Install lower bushing ③ and swivel bracket seal ④ to swivel bracket.

NOTE:

Install seal ④ with lip (spring side) facing downward.

4. Install steering bracket ⑤ to swivel bracket.

CAUTION

Do not re-use seal once removed. Always use a new seal.

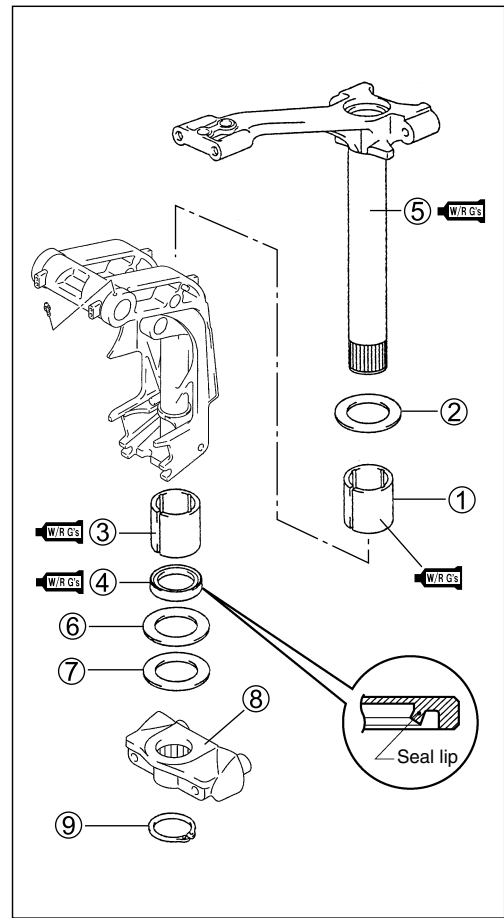

LOWER MOUNT BRACKET

1. Install washer ⑥ and shim ⑦, and then slide lower mount bracket ⑧ upward on splines until it contacts shim.
2. Install circlip ⑨ to retain bracket.

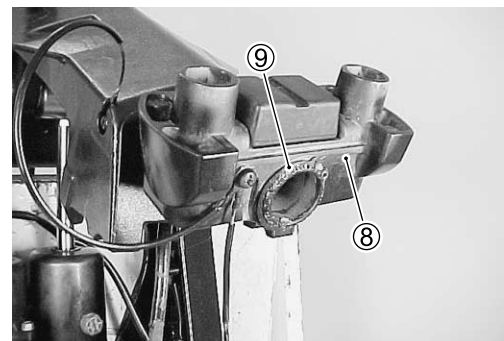
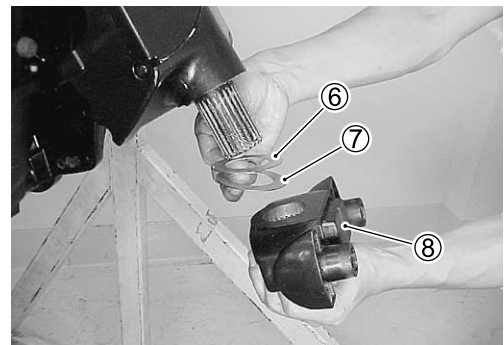

BONDING WIRE

Reattach bonding wire, then tighten screw securely.

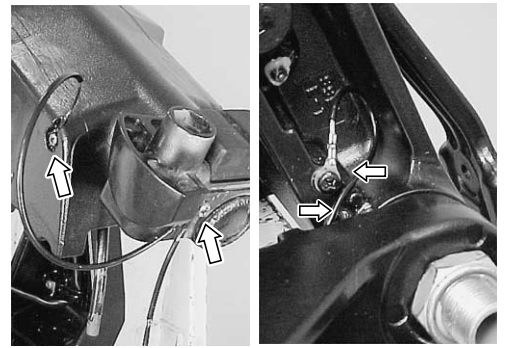
**LUBRICATION**

After completing reassembly of mid unit, apply grease through each grease nipple.

 **99000-25160 : Suzuki Water Resistant Grease**

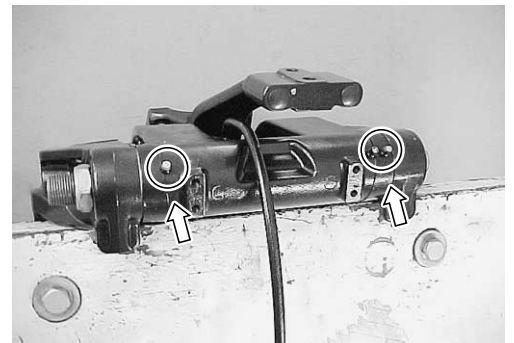
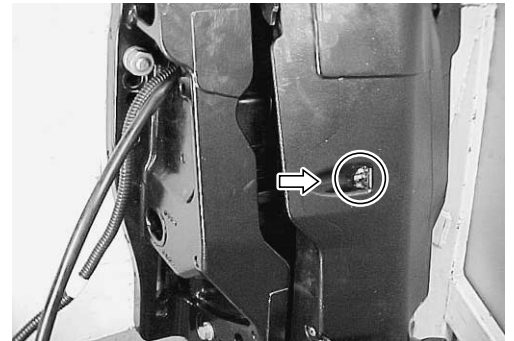

WATER PRESSURE VALVE

REMOVAL

1. Remove PORT side lower cover. (See page 7-2)
2. Remove two bolts ①, pressure valve cover ② and water pressure valve ③.

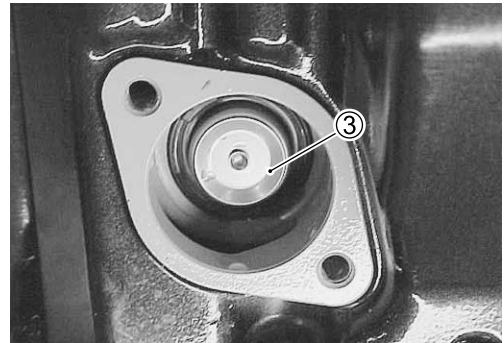
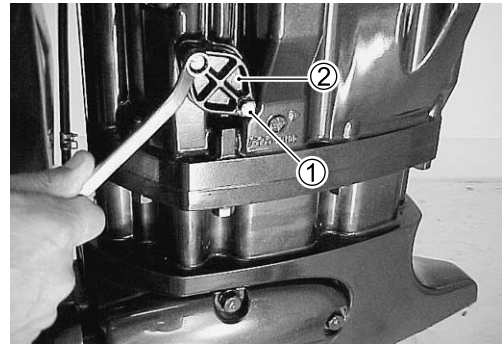

INSPECTION

Inspect water pressure valve and valve cover for salt deposits, corrosion, wear or other damage.
Clean or replace if necessary.



INSTALLATION

1. Install O-ring ① to pressure valve cover.
2. Install pressure valve ②, and pressure valve cover ③ to oil pan and secure with bolts.

NOTE:

Align projections on valve's seal rubber with cutaway parts on valve cover when installing.

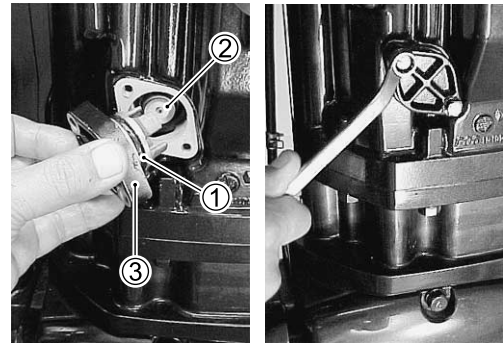

CAUTION

Do not re-use O-ring once removed. Always use a new O-ring.

POWER TRIM AND TILT

CONTENTS

SYSTEM WIRING DIAGRAM	8-2
SERVICE PROCEDURE	8-3
OIL LEVEL	8-3
AIR BLEEDING	8-3
POWER TRIM AND TILT UNIT	8-4
REMOVAL	8-4
DISASSEMBLY	8-5
INSPECTION	8-7
REASSEMBLY	8-9
PTT MOTOR	8-10
PTT MOTOR REMOVAL	8-10
PTT MOTOR DISASSEMBLY	8-11
PTT MOTOR INSPECTION	8-12
PTT MOTOR ASSEMBLY	8-13
PTT MOTOR INSTALLATION	8-14
INSTALLATION	8-15
PTT MOTOR RELAY	8-17
PTT SWITCH	8-18
OPERATION	8-19
COMPONENTS	8-19
PRINCIPLES OF OPERATION	8-20

SYSTEM WIRING DIAGRAM

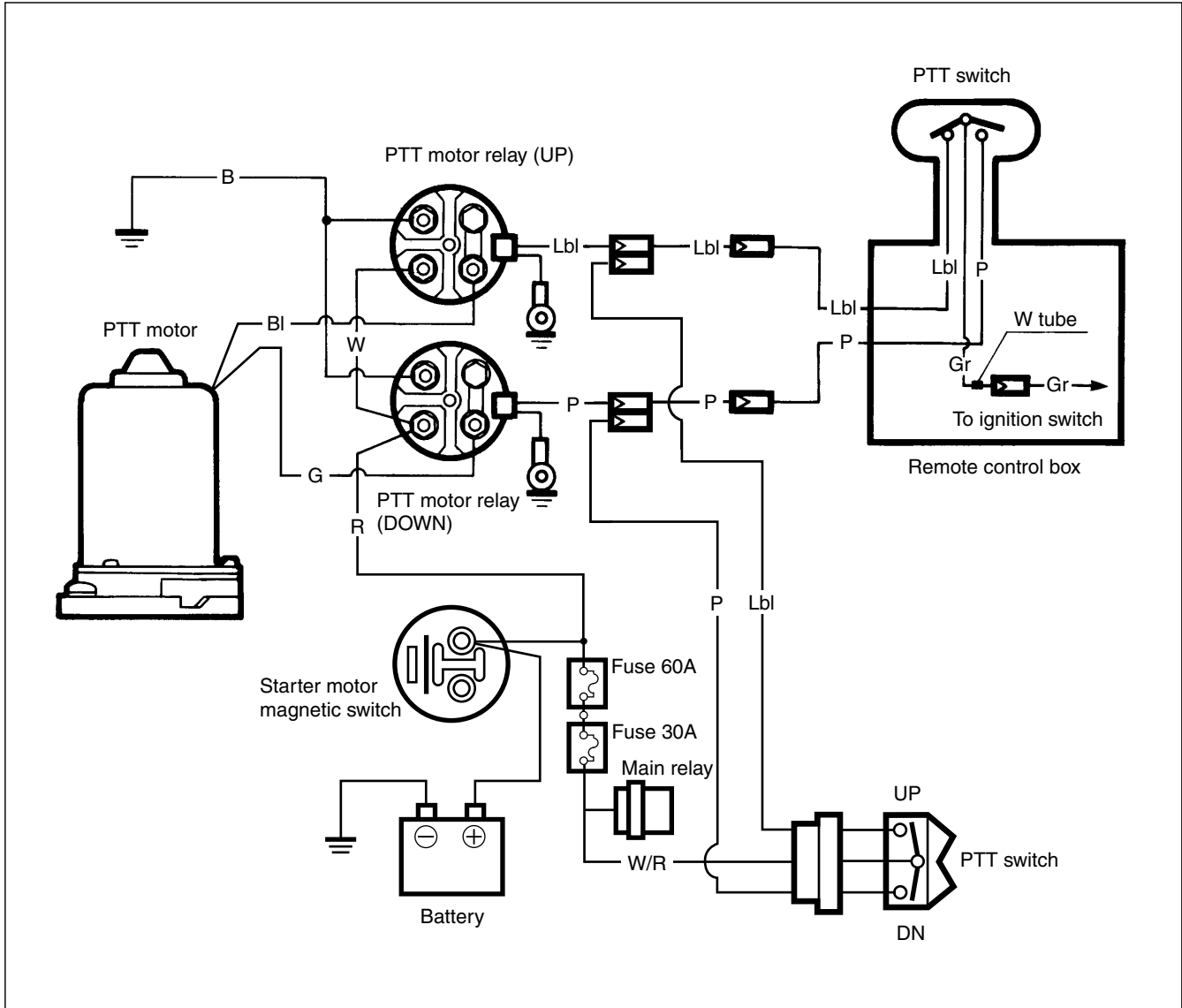

SERVICE PROCEDURE

OIL LEVEL

To check PTT oil level :

1. Raised engine to a full-tilt position.
2. Lower manual tilt lock lever ①.
3. Remove oil filler plug ②.
4. If oil can be seen at filler plug level, unit is full.
5. If oil level is low, refill with recommended oil.

Recommended oil :

Dexron III automatic transmission fluid or equivalent

CAUTION

To ensure consistent pump operation, do not mix different types of oil.

6. Reinstall oil filler plug.

AIR BLEEDING

1. Check that manual release valve is tightened to specified torque.

 **Manual release valve : 3.6 N·m (0.36 kg-m, 2.6 lb.-ft.)**

CAUTION

Do not over-tighten manual release valve.

Counterclockwise = open
Clockwise = close

2. Operate PTT switch, raising and lowering motor up and down (full tilt position to full trim down position) 4 to 5 times.
3. Check oil level, topping off if necessary.
4. Reinstall oil filler plug.

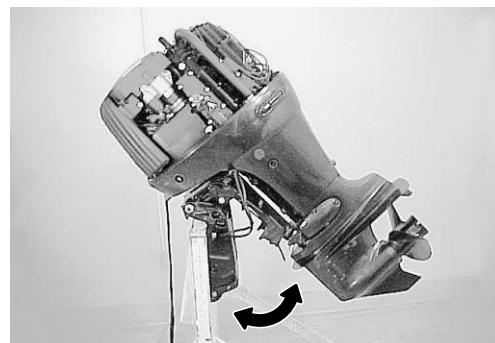
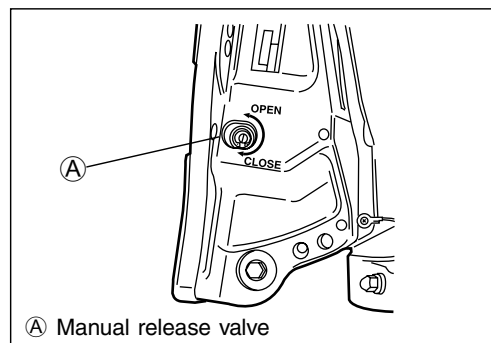
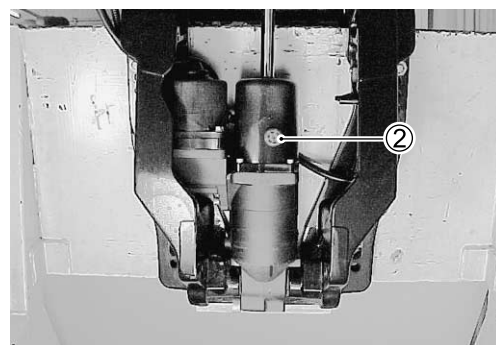

POWER TRIM AND TILT UNIT REMOVAL

Raise engine to the full tilt position and lower manual tilt lock levers ①.

⚠ WARNING

During the following procedures, the engine must be firmly secured and its weight fully supported. (See right)

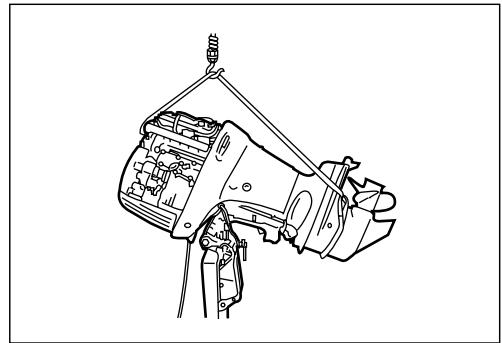

1. Remove tilt rod snap ring ② and push tilt cylinder upper shaft pin ③ out.

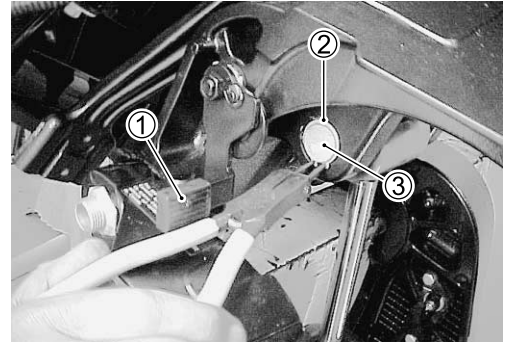

2. Lower tilt rod to full down position and disconnect battery cable.

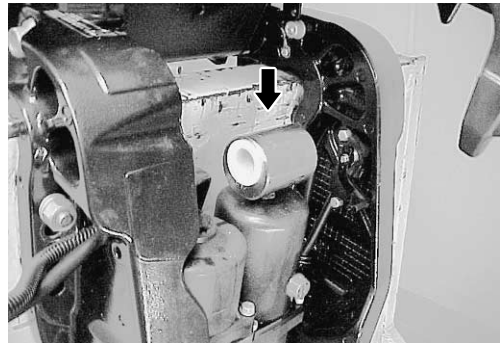

3. Disconnect PTT motor cable wire leads (Green, Blue) from PTT motor relays.
4. Remove PTT motor cable from engine lower cover.

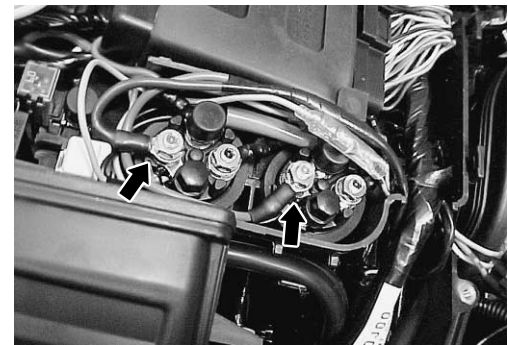

5. Remove STBD motor mounting bolts ④ and clamp bracket shaft nut ⑤.

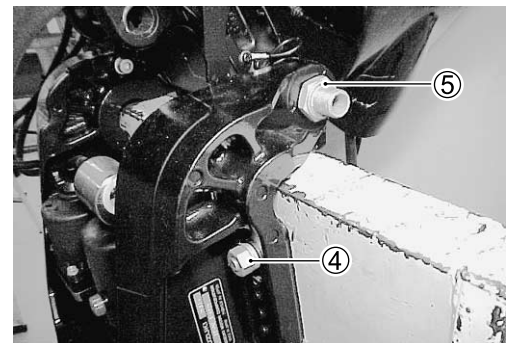

6. Remove PTT cylinder lower shaft bolts ⑥.
7. Remove two bolts and anode ⑦.

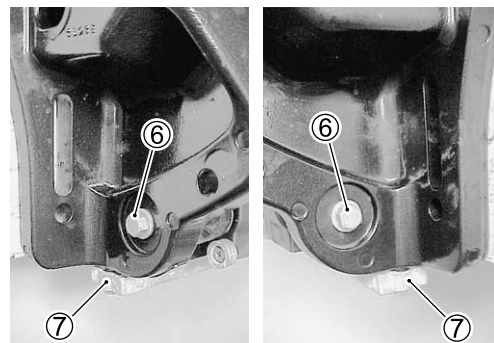

8. Slide STBD clamp bracket ⑧ off clamp bracket shaft, then remove PTT unit.

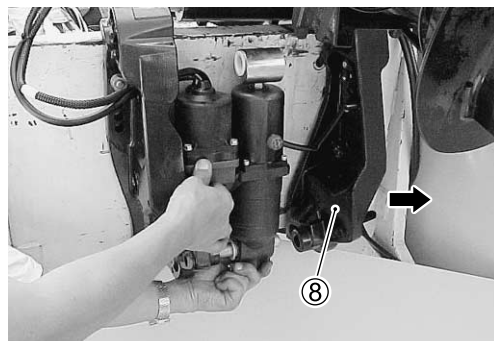

DISASSEMBLY

NOTE:

Before disassembly, wash PTT body with a stiff bristle brush and hot, soapy water to remove sand or dirt and dry PTT body with compressed air.

1. Place lower mounting eye of PTT cylinder in a vise. Tighten vise only enough to secure PTT unit, do not over tighten.

NOTE:

To prevent damage to PTT cylinder use wood blocks, vise jaw protectors, etc., between vise jaws and PTT components before tightening vise.

2. Connect PTT motor cable leads (Green, Blue) to battery and operate PTT motor until tilt piston rod is at maximum stroke. (full-tilt up position)
3. Remove PTT motor. (See page 8-10)
Note position of drive joint ③ and O-ring ④, before removing them.
4. Remove fill plug and drain PTT oil into suitable container.

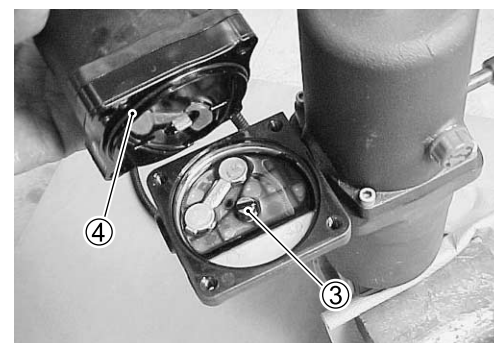

8-6 POWER TRIM AND TILT

5. Remove manual release valve snap ring ⑤, then remove manual release valve ⑥.

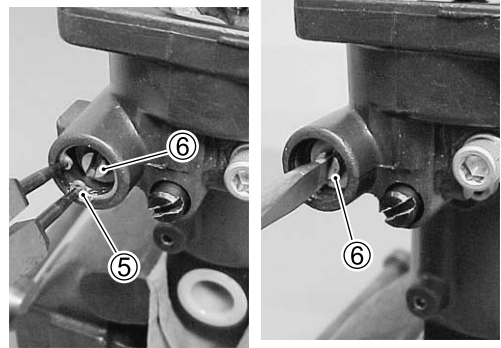

6. Remove three bolts securing PTT pump case ⑦, then detach PTT pump case from PTT body. Note position of O-rings and remove them.

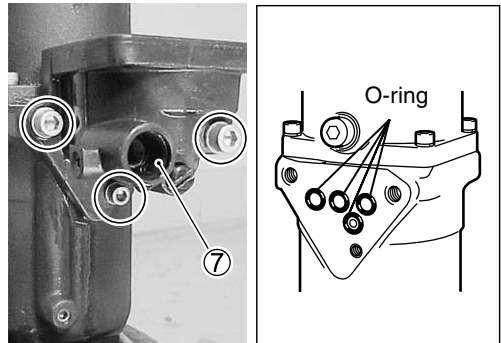

7. Remove upper eye ⑧.

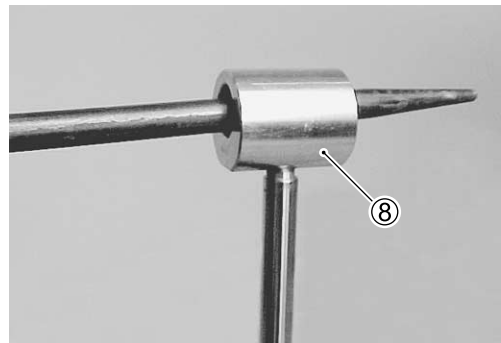

8. Remove four bolts securing cylinder cover ⑨, then detach cover from PTT body.
9. Remove O-ring ⑩.

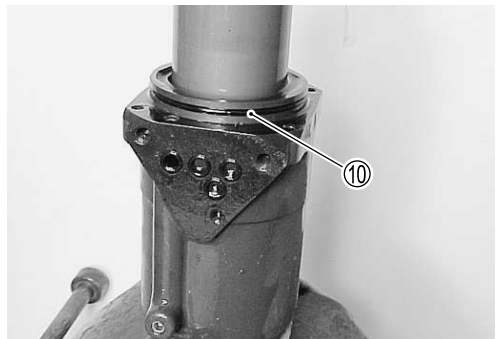
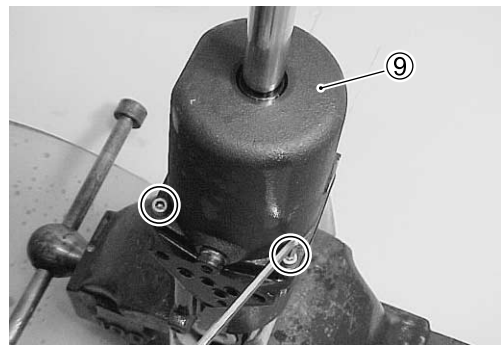

INSPECTION

Arrange all components on a clean sheet of paper.

NOTE:

Do not lay PTT components out on a rag, as dirt or lint may be transferred to these items which may cause possible system operating problems.

NOTE:

If excessive wear, cracks, defective or other damage is found on any component, replace component.

- Inspect PTT pump case for cracks, nicks, stripped threads and any other imperfections.
Replace if necessary.

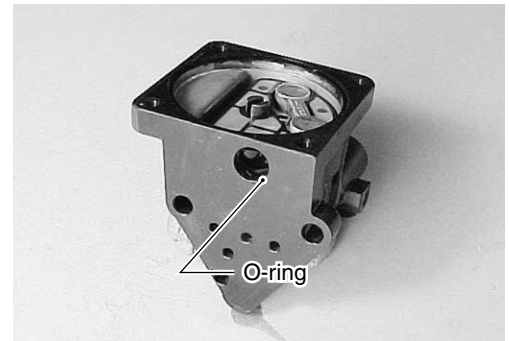

- Inspect cylinder cover for cracks, nicks or damage.
Replace if necessary.
- Inspect cylinder cover seal for cuts, nicks or wear.



- Inspect all O-rings for cuts, nicks or tears.

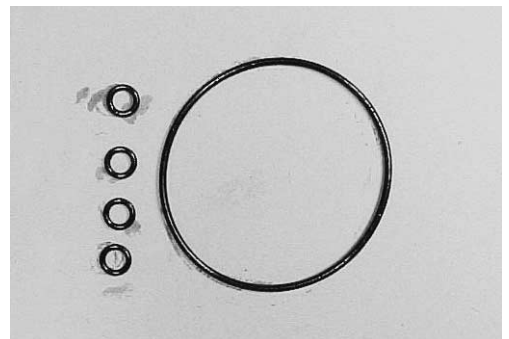

8-8 POWER TRIM AND TILT

- Inspect manual release valve for damage.
Replace if necessary.
- Inspect O-rings for cuts, nicks or tears.



- Inspect lower shaft and upper shaft for bent, twist or other damage.
Replace if necessary.
- Inspect all bushings for excessive wear or other damage.
Replace if necessary.
If bushing fit is loose when installing, replace bushing.

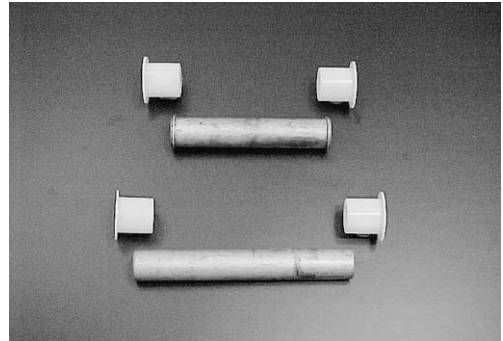

REASSEMBLY

Assembly is reverse order of disassembly with special attention to the following steps.

CAUTION

- Do not re-use O-ring and seal once removed. Always use new parts.
- Lubricate all components and O-rings with PTT fluid before assembly.
- Do not re-use PTT fluid. Always refill with new fluid.

TILT CYLINDER COVER

1. Apply PTT fluid to cylinder cover seal, then install cylinder cover.
2. Tighten four bolts securely.

 Cylinder cover bolt : 4.7 N·m (0.47 kg-m, 3.4 lb.-ft.)

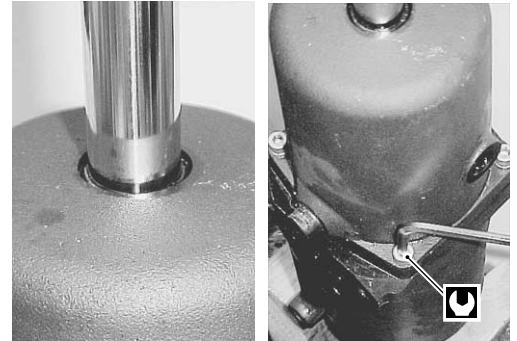

UPPER EYE

1. Apply Thread Lock super 1333B to threads of upper eye before threading it onto tilt rod.
2. Tighten upper eye to specified torque.

 Upper eye : 108 N·m (10.8 kg-m, 78.0 lb.-ft.)

 99000-32020 : Thread Lock super 1333B

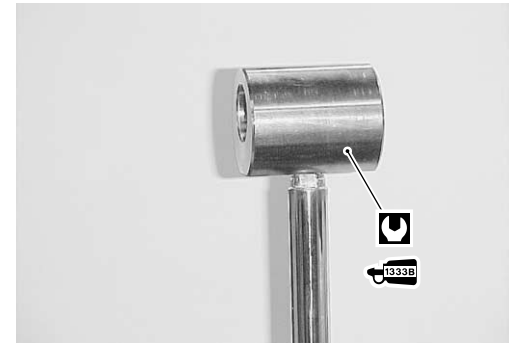

PTT PUMP CASE

1. Install four O-rings to PTT body.

NOTE:

Lubricate O-ring with PTT fluid before installing PTT body.

2. Install PTT pump case, then tighten three bolts to specified torque.

 PTT pump case bolt :

① 8 N·m (0.8 kg-m, 5.8 lb.-ft.)

② 5.5 N·m (0.55 kg-m, 4.0 lb.-ft.)

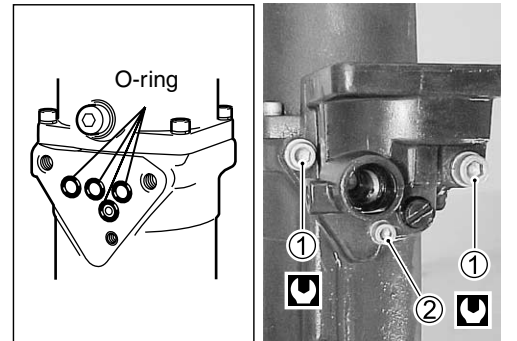

MANUAL RELEASE VALVE

1. Oil and install seal washer ① and manual release valve ②.
2. Tighten valve to specified torque.

 Manual release valve : 3.6 N · m (0.36 kg-m, 2.6 lb.-ft.)

3. Install snap ring ③.

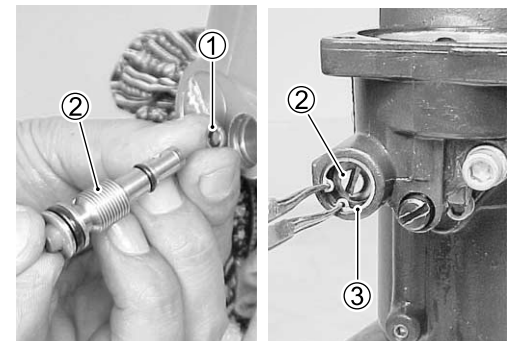

PTT MOTOR

See PTT MOTOR INSTALLATION section on page 8-14.

AIR BLEEDING

- Pour recommended PTT fluid in to reservoir until specified level.
- Perform air bleeding procedure.
See AIR BLEEDING section on page 8-3.

PTT MOTOR

PTT MOTOR REMOVAL

NOTE:

Before removing PTT motor, wash the PTT body with a stiff bristle brush and hot, soapy water to remove sand or dirt and dry PTT body with compressed air.

1. Place lower mounting eye of PTT cylinder in a vise. Tighten vise only enough to secure PTT unit, do not over tighten.

NOTE:

To prevent damage to PTT cylinder use wood blocks, vise jaw protectors, etc., between vise jaws and PTT components before tightening vise.

2. Remove four bolts securing PTT motor to PTT pump case.

3. Detach PTT motor from PTT pump case.
Note position of drive joint ① and O-ring ② and remove them.

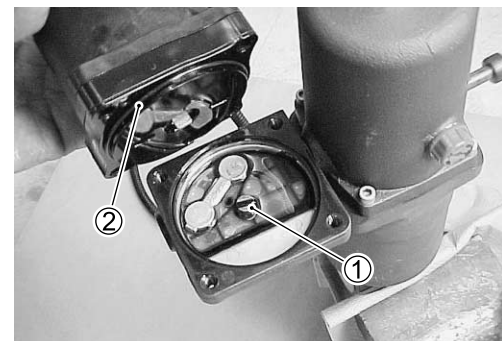
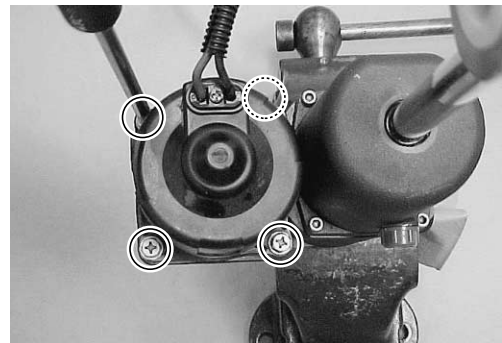

PTT MOTOR DISASSEMBLY

1. For correct assembly, scribe an alignment mark on field case and brush holder.
2. Remove tape from PTT motor cables and cable protector tube, then slide cable protector tube upward.
3. Remove screw securing motor cable holder ①, then slide motor cable holder and grommets ② out as shown in figure.
4. Remove two screws ③ securing field case to brush holder.

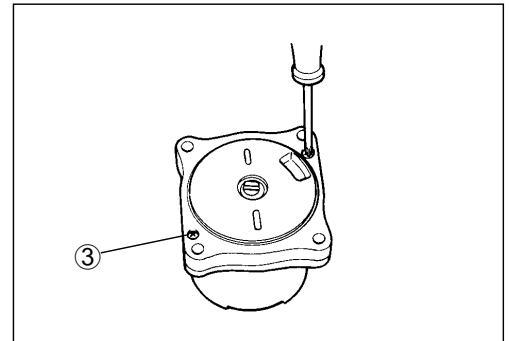
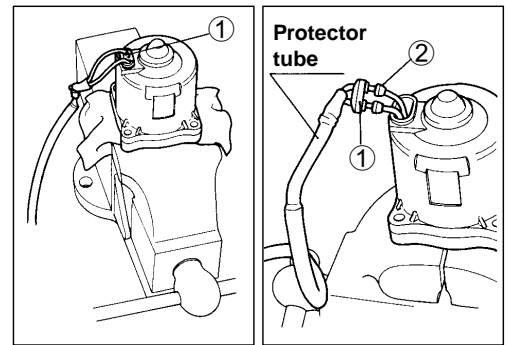

5. Slide field case upward and away from brush holder.

NOTE:

When separating field case from brush holder, proceed by pushing PTT motor cables into brush holder side.

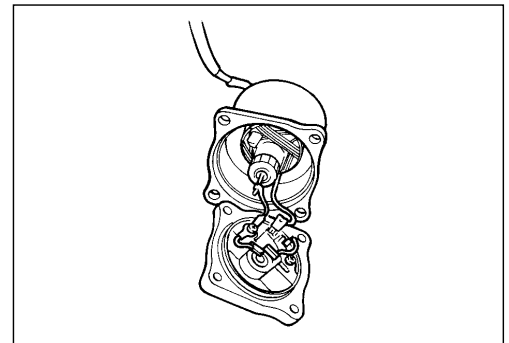

6. Disconnect PTT motor cables from brush holder.
7. Remove armature from field case.
Note position of O-ring encircling brush holder.

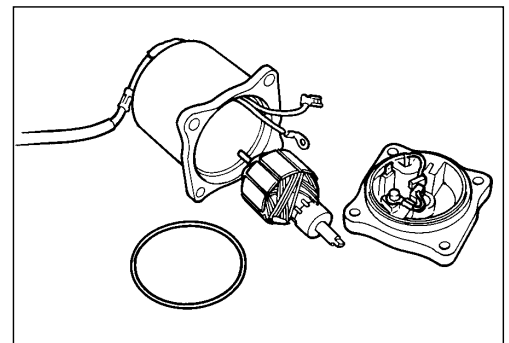



PTT MOTOR INSPECTION

Armature and Commutator

1. Inspect continuity between commutator and armature core / shaft.
If continuity exists, replace armature.

 **09930-99320 : Digital tester**

 **Tester range :  (Continuity)**

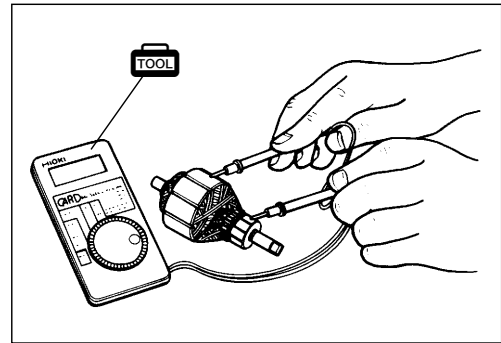

2. Inspect continuity between adjacent commutator segments.
If no continuity exists, replace armature.

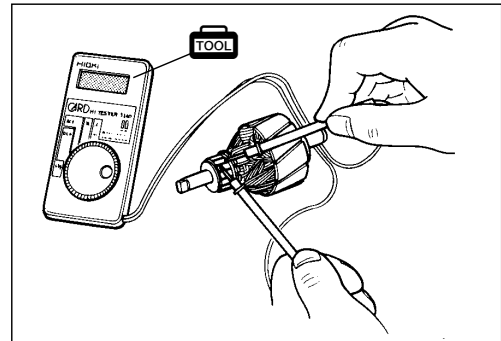

3. Inspect commutator surface for gum or dirt.
Clean with #500 grit emery paper if necessary.

Measure commutator outside diameter.

 **09900-20101 : Vernier calipers**

Commutator outside diameter :
Standard : 22.0 mm (0.87 in.)
Service limit : 21.0 mm (0.83 in.)

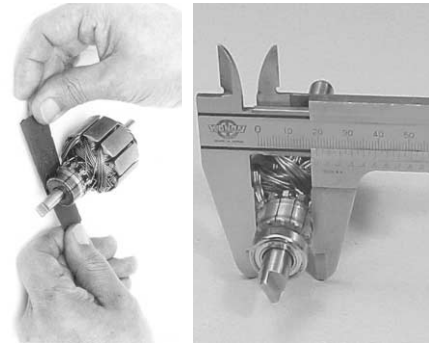

If measurement exceeds service limit, replace armature.

4. Measure commutator undercut (depth) between mica (insulator) and segments.

Commutator undercut ① (depth) :
Standard : 1.6 – 1.9 mm (0.06 – 0.07 in.)
Service limit : 1.3 mm (0.05 in.)

If measurement exceeds service limit, cut mica to specified depth.

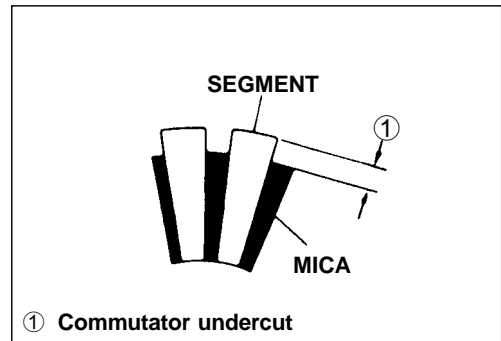

NOTE:

Remove all particles of mica and metal using compressed air.

⚠ WARNING

Wear safety glasses when using compressed air.

Brushes

Measure length of each brush.

 **09900-20101 : Vernier calipers**

Brush length :

Standard : 9.8 mm (0.39 in.)

Service limit : 5.5 mm (0.22 in.)

If measurement exceeds service limit, replaced brush.

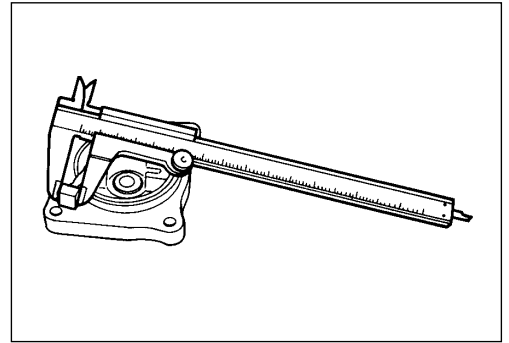
**O-ring**

Inspect O-ring between PTT motor and PTT pump case for cuts, nicks or tears.

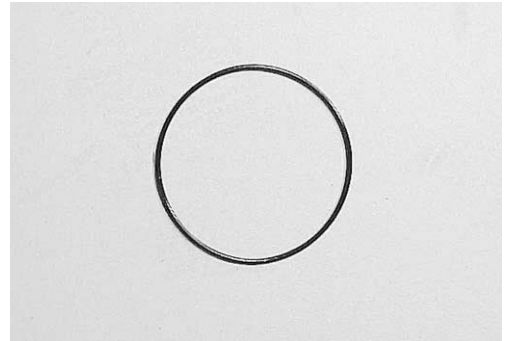
**PTT MOTOR ASSEMBLY**

Assembly is reverse order of disassembly with special attention to the following steps.

1. Install armature to brush holder first.

CAUTION

When installing armature, exercise care to avoid breaking brushes.

2. Match up previously scribed alignment marks.
3. When assembling field case to brush holder, proceed by pulling PTT motor cables out of field case.
4. Apply Silicone Seal to PTT motor cable holder and grommets, then install cable holder screw.

 **99000-31120 : Suzuki Silicone Seal**

5. Fix cable protector tube to PTT motor cables with heat-resisting tape.

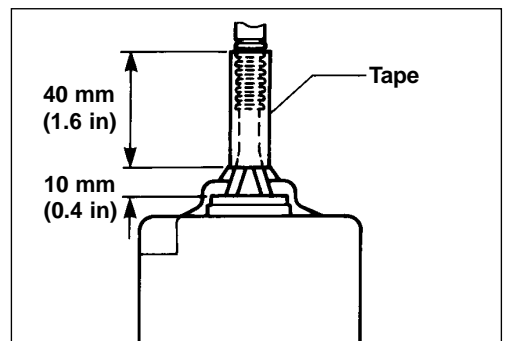
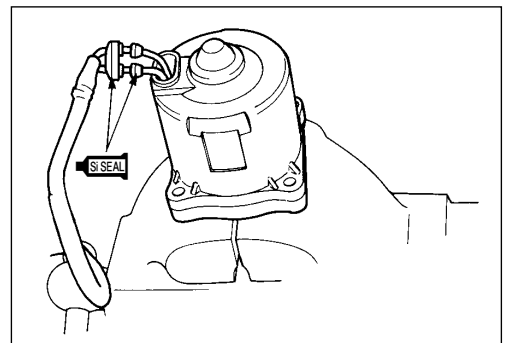
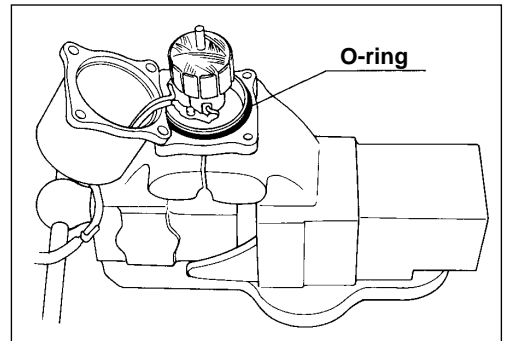

PTT MOTOR INSTALLATION

Installation is reverse order of removal with special attention to the following steps.

1. Ensure that drive joint ① is aligned and firmly inserted into gear pump assembly.
2. Fit O-ring ② to PTT motor.
3. Check level of PTT fluid contained in PTT pump case. If level is low, add recommended PTT fluid until level with mating surface of PTT motor.
4. Ensure that faces of PTT motor and pump unit are free of dirt or debris.
When attaching PTT motor to PTT pump case, ensure that tip of armature shaft fits firmly into drive joint ①.
5. Tighten four bolts to specified torque.

 **PTT motor screw : 5 N·m (0.5 kg·m, 3.6 lb.-ft.)**

6. Pour recommended PTT fluid into reservoir until specified level.
7. Perform air bleeding procedure.
See AIR BLEEDING section on page 8-3.

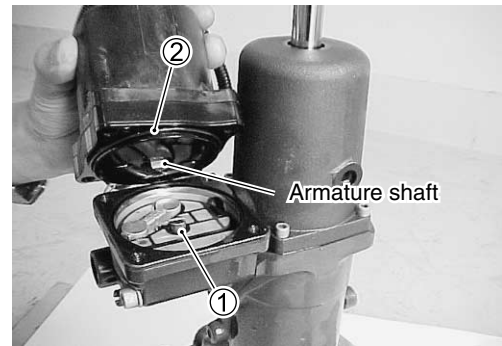

INSTALLATION

Installation is reverse order of removal with special attention to the following steps.

1. Lower tilt rod to full down position.
2. Apply Water Resistant Grease to tilt cylinder lower shaft and lower shaft bushes.
3. Install bushings ① and cylinder lower shaft ② to PTT unit.

 **99000-25160 : Water Resistant Grease**

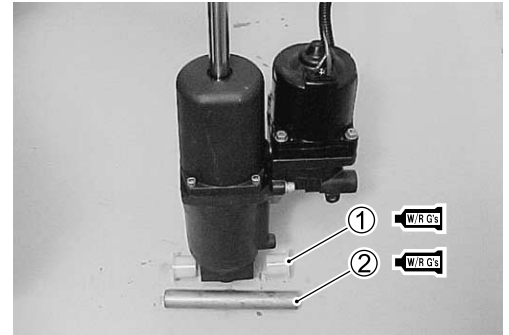

4. Place PTT unit in position, then install clamp bracket.
5. Tighten clamp bracket shaft nut to specified torque.

 **Clamp bracket shaft nut :**

43 N · m (4.3 kg-m, 31.0 lb.-ft.)

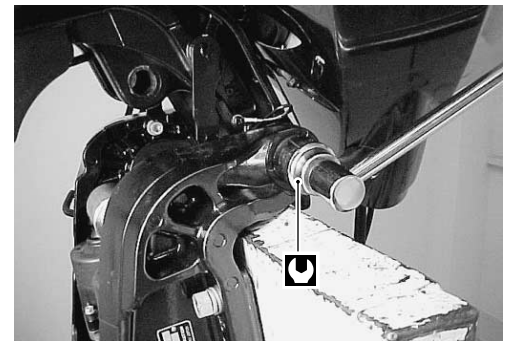
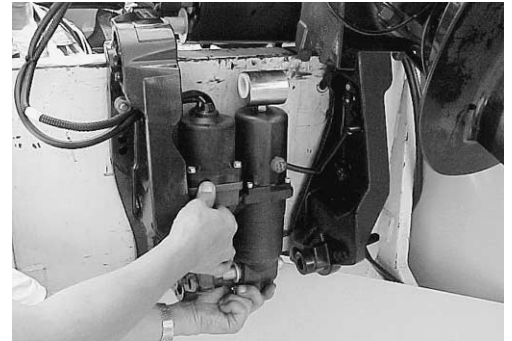

6. Tighten lower shaft bolts ④, pre-coated with thread lock, to specified torque.

 **99000-32050 : Thread Lock "1342"**

 **Cylinder lower shaft bolt : 50 N · m (5.0 kg-m, 36.0 lb.-ft)**

7. Install anode ⑤, then tighten bolts securely.

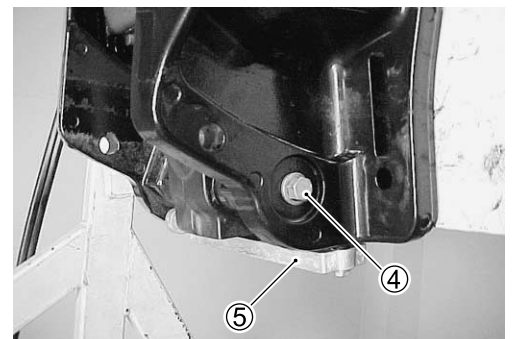

8-16 POWER TRIM AND TILT

8. Apply Water Resistant Grease to tilt rod upper bushings ⑥, then install bushings in tilt rod.
9. Operate PTT motor to extend PTT rod upward.
Align tilt rod with hole in swivel bracket as tilt rod extends.

 **99000-25160 : Water Resistant Grease**

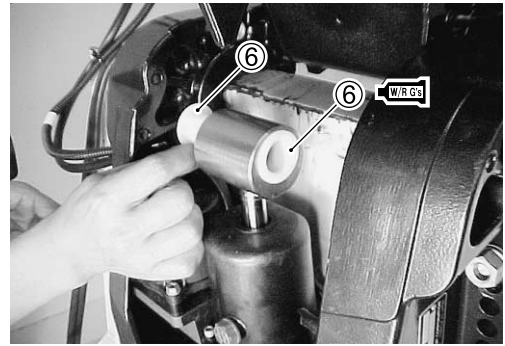

10. Apply Water Resistant Grease to PTT rod upper shaft ⑦, then insert shaft through swivel bracket and tilt rod.

 **99000-25160 : Water Resistant Grease**

11. Secure upper shaft with snap ring ⑧.

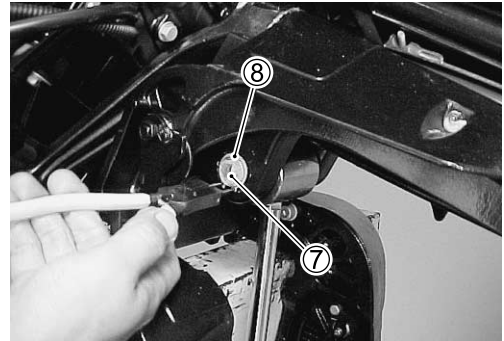

12. Route PTT motor cable in through lower cover and connect terminals to PTT motor relays.
(Cable routing – See WIRE / HOSE ROUTING section on page 10-2 to 10-5)

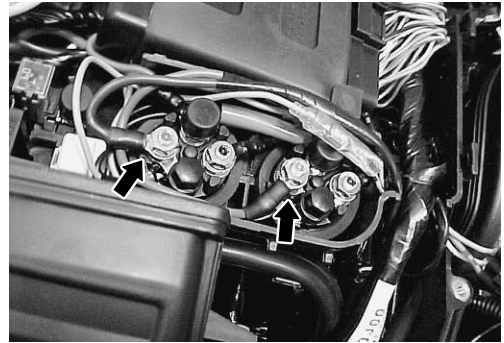

PTT MOTOR RELAY

Two methods can be used to test PTT motor relays.

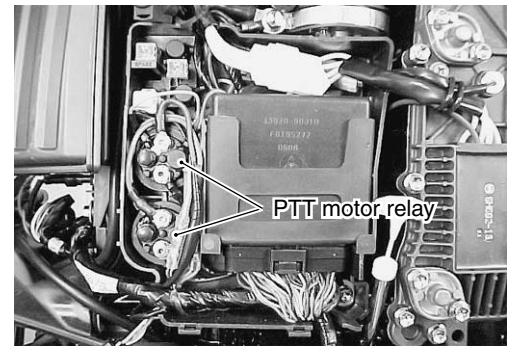

Method 1.

Measure resistance between two lead wires of relay.

 **09930-99320 : Digital tester**

 **Tester range : Ω (Resistance)**

	Tester probe connection	
	Red \oplus	Black \ominus
UP relay	Light Blue	Black
DOWN relay	Pink	Black

PTT motor relay solenoid coil resistance : 3.0 – 4.5 Ω

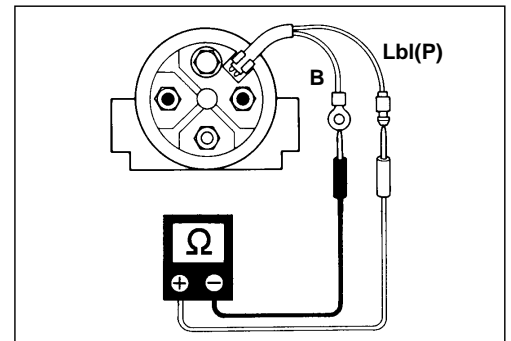

Method 2.

1. Inspect relay operation using battery (12V) as follows:

 **09930-99320 : Digital tester**

 **Tester range : \rightarrow (Continuity)**

(1) Without lead wires connected to battery, there should be continuity between terminals ①, ② and ③ but should be no continuity between terminals ③ and ④.

(2) With Black lead wire connected to battery negative \ominus terminal and Light blue (or Pink) lead wire connected to battery positive \oplus terminal, there should be continuity between terminals ②, ③ and ④.

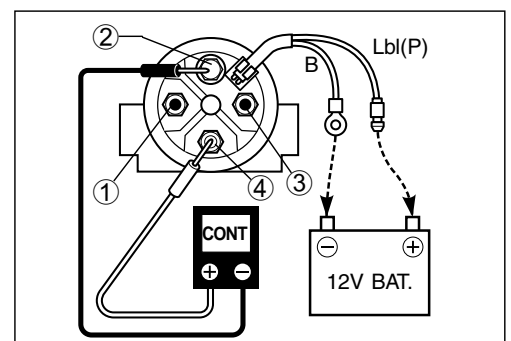
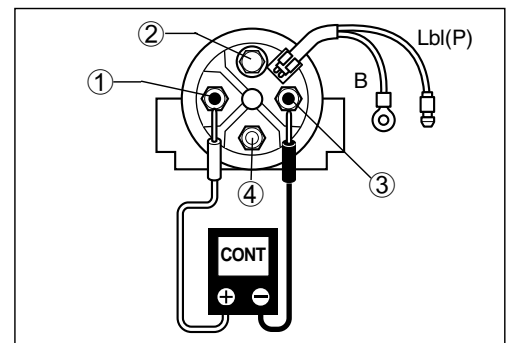

2. The relay is considered to be without defect if continuity test results are as stated above.



PTT SWITCH

Test continuity between switch lead wires at each of three switch positions.

 **09930-99320 : Digital tester**

 **Tester range :  (Continuity)**

	Tester probe connection		Continuity
	Red ⊕	Black ⊖	
“DN” side depressed	Pink	Gray (White / Red)	Yes
“UP” side depressed	Light Blue	Gray (White / Red)	Yes
not depressed	Pink	Gray (White / Red)	No
	Light Blue		

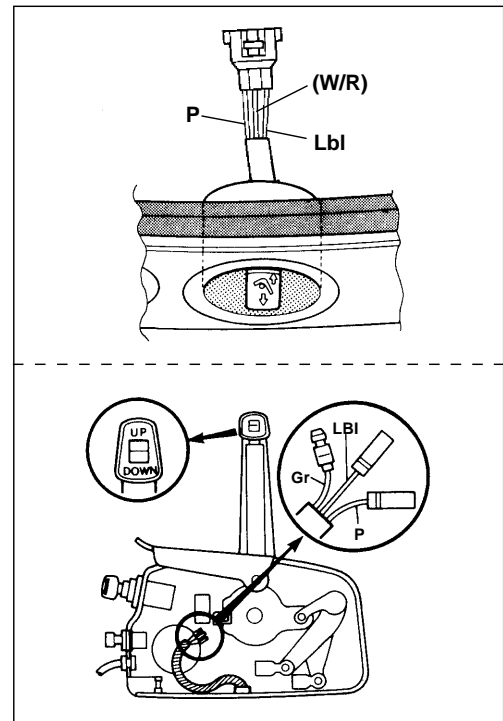

OPERATION

The power trim and tilt system is operated by a “rocker” type switch (protected by a rubber thumb pad) on top of the remote control box handle.

When the switch is depressed, power is delivered to the electric motor via the relevant relay. The relay with the Blue wire connected to the PTT pump is for trim / tilt “UP”, while the relay with the Green wire is for trim / tilt “DOWN”.

COMPONENTS

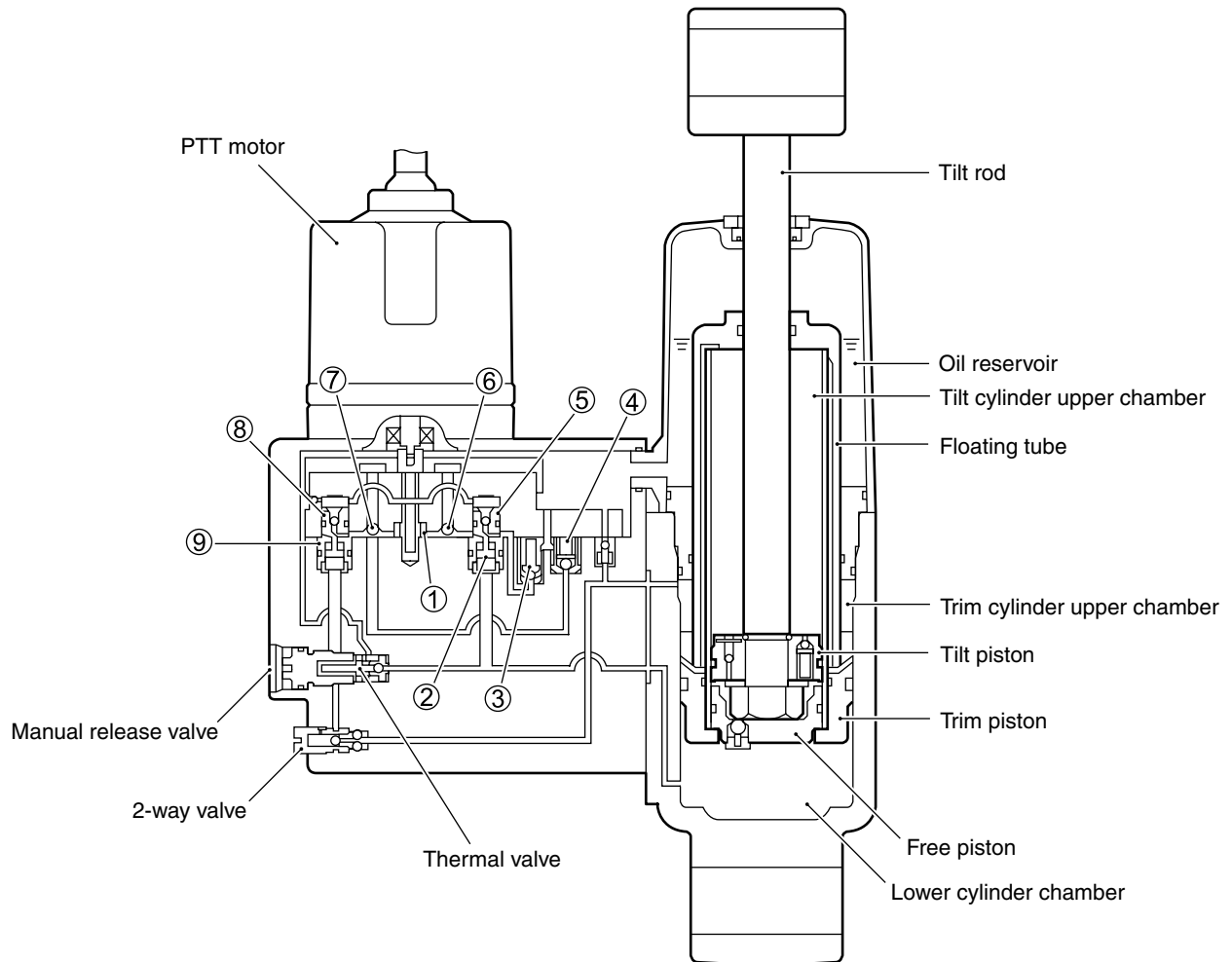

- | | |
|----------------------------------|------------------------------------|
| ① Gear pump | ⑥ Check valve Ⓑ |
| ② “UP” pressure main check valve | ⑦ Check valve Ⓐ |
| ③ “UP” relief valve | ⑧ Spool valve Ⓐ |
| ④ “DOWN” relief valve | ⑨ “DOWN” pressure main check valve |
| ⑤ Spool valve Ⓑ | |

PRINCIPLES OF OPERATION

TRIM / TILT “UP” CIRCUIT

When the PTT switch is operated “UP” position, the electric motor and gear pump ④ will operation on clockwise direction.

Pressurized oil will open check valve ①, oil will flow from reservoir to spool valve ① via pump and spool valve ②.

The spool valve ① will down, then “DOWN” pressure main check valve ① will open.

Oil in the upper chamber will return to pump via 2-way valve, and then oil pressure will rise and open “UP” pressure main check valve ②, then oil will flow to lower cylinder chamber of cylinder.

It makes the piston rod push up and the engine tilt up.

To keep oil level, oil flows from reservoir to pump through the check valve ③.

Oil through the “DOWN” pressure main check valve ① and returns to pump.

When trim motor stops, both the “DOWN” pressure main check valve ① and the “UP” pressure main check valve ② will close to retain tilt / trim position.

In the trim area, trim piston and floating tube are moving with piston rod.

When full trim / tilt “UP” position is attained, sustained operation of the “UP” relay will have no effect, as pump oil flow will be returned to the reservoir through the “UP” relief valve ③.

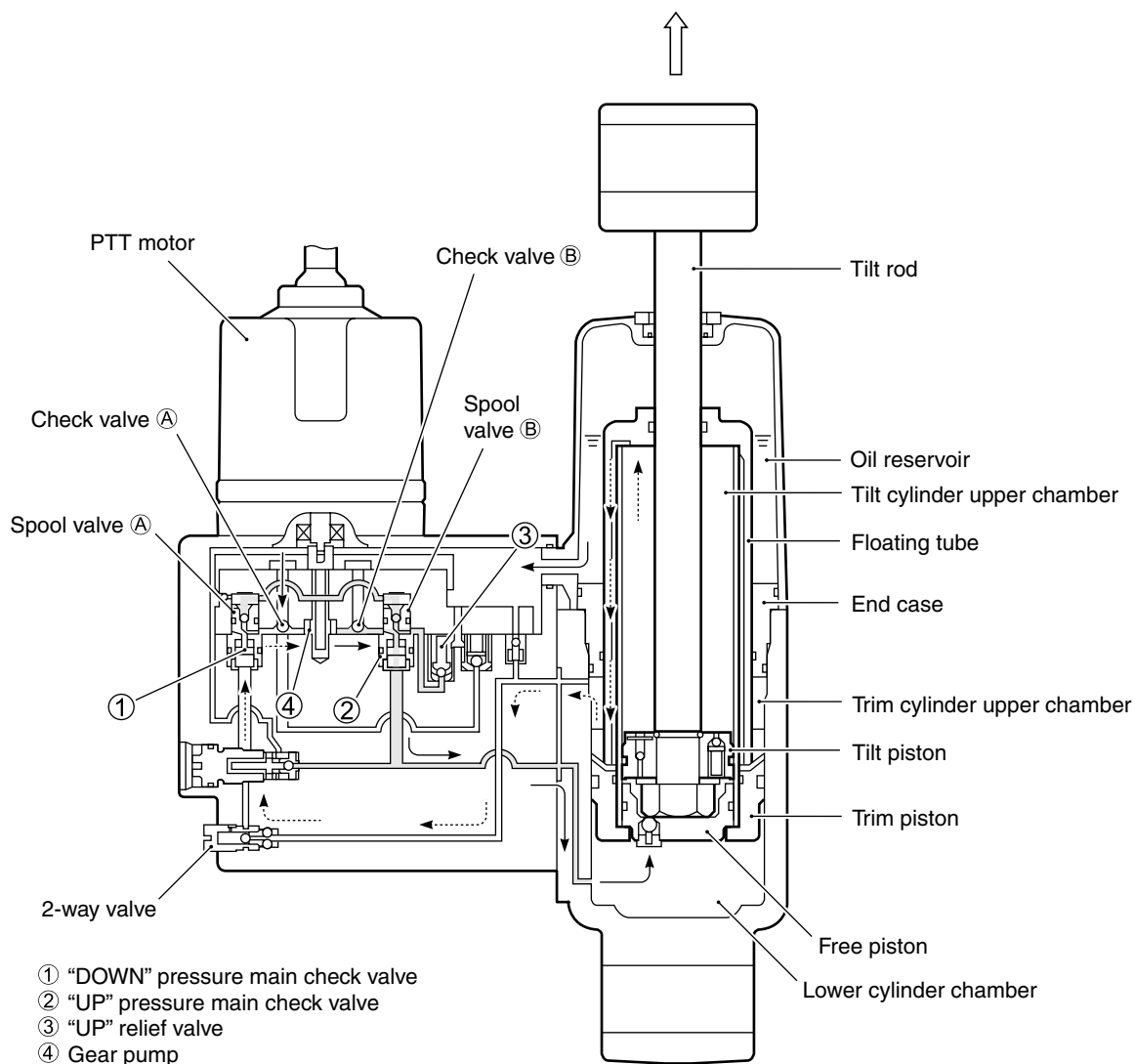

TRIM / TILT “DOWN” CIRCUIT

When the PTT switch is operated “DOWN” position, the electric motor and gear pump will operation on counterclockwise direction.

Check valve (B) will open ; oil will flow from reservoir to spool valve (A).

It makes spool valve (B) move to downward, then “UP” pressure main check valve (2) open.

Oil in the lower chamber will return to pump, and then oil pressure will rise and open “DOWN” pressure main check valve (1), then oil will flow to upper cylinder chamber of cylinder.

It makes the piston rod push down and the engine will tilt down.

To keep oil level, oil flows from reservoir to pump through the check valve (B).

Surplus oil in the pump throughs the “DOWN” relief valve (3) and returns to reservoir.

When trim motor stops, both the “DOWN” pressure main check valve (1) and the “UP” pressure main check valve (2) will close to retain tilt / trim position.

In the trim area, trim piston and floating tube are moving with piston rod.

When full trim / tilt “DOWN” position is attained, sustained operation of the “DOWN” relay will have no effect, as pump oil flow will be returned to the reservoir through the “DOWN” relief valve (3).

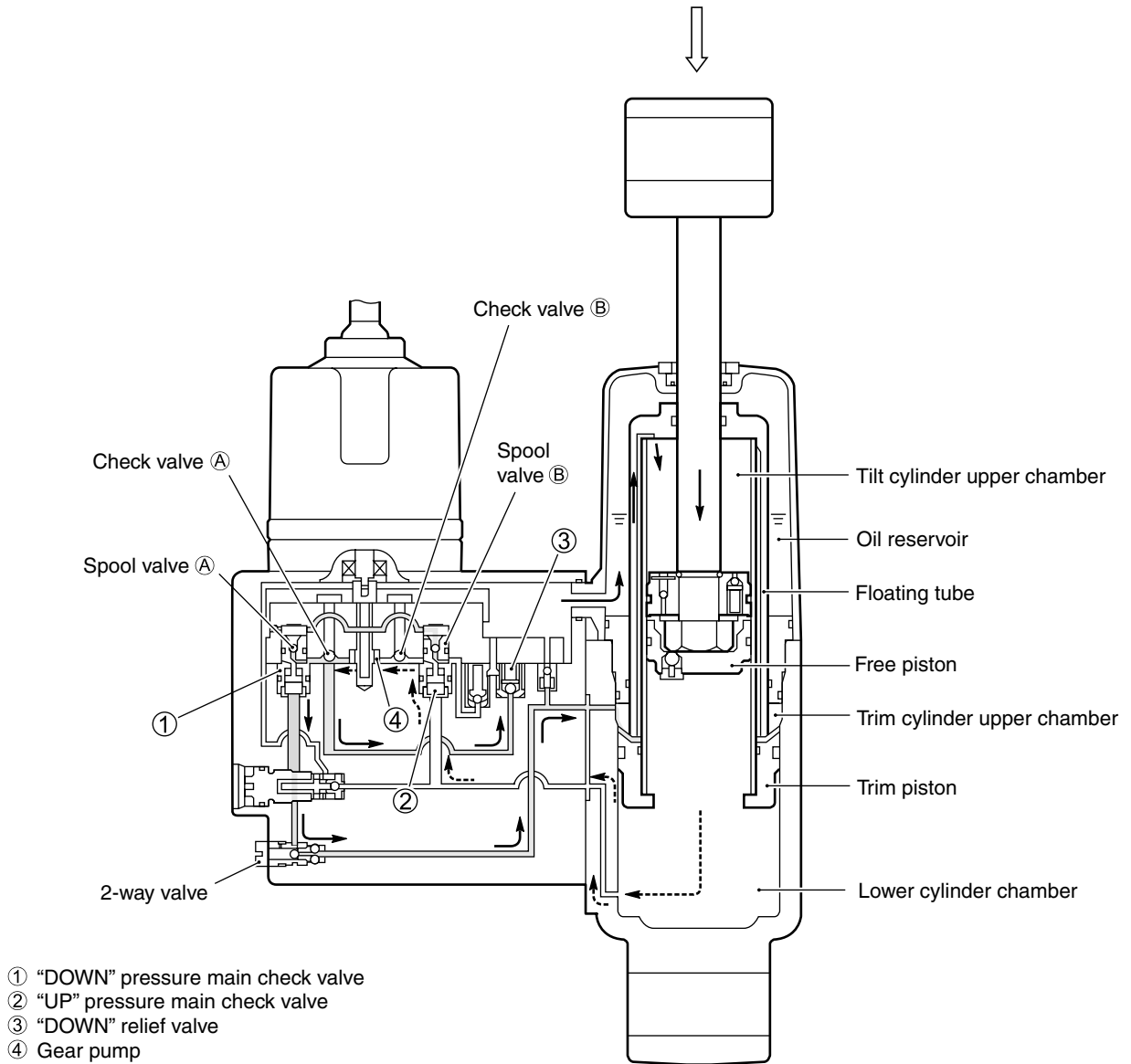

SHOCK ABSORBER CIRCUIT

(i) Shock valve

Should the lower unit strike an underwater object whilst in motion, the piston will rise abruptly, creating a sudden high impact pressure in the upper cylinder chamber. The shock valve will then open, allowing oil to flow into the area between the tilt ram piston and the free piston, thereby dampening (absorbing) the impact.

(ii) Return valve

When the point of impact has passed, propeller thrust and motor weight will force the tilt ram piston back downwards. The oil from between the ram piston and the free piston is then expelled through the return valve before flowing into the upper cylinder chamber.

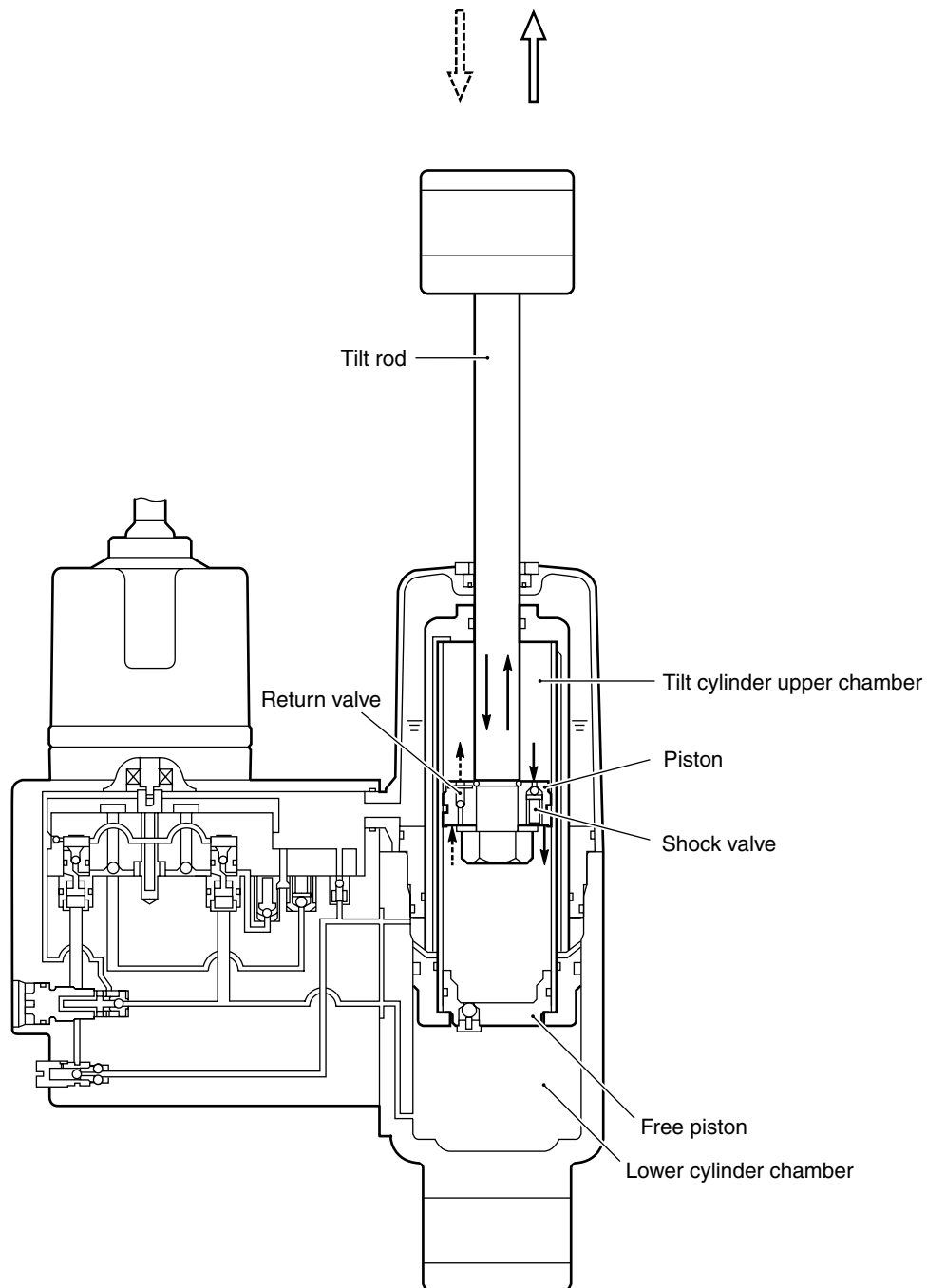

MANUAL RELEASE CIRCUIT (MANUAL VALVE)

Operation : Turn manual valve maximum three (3) full turns counterclockwise.
 When the manual valve is loosened, oil will flow unimpeded (without resistance) through the internal pump tubes, thereby facilitating manual tilting or lowering of the outboard. To hold the engine in a selected position, the manual valve must be closed again.

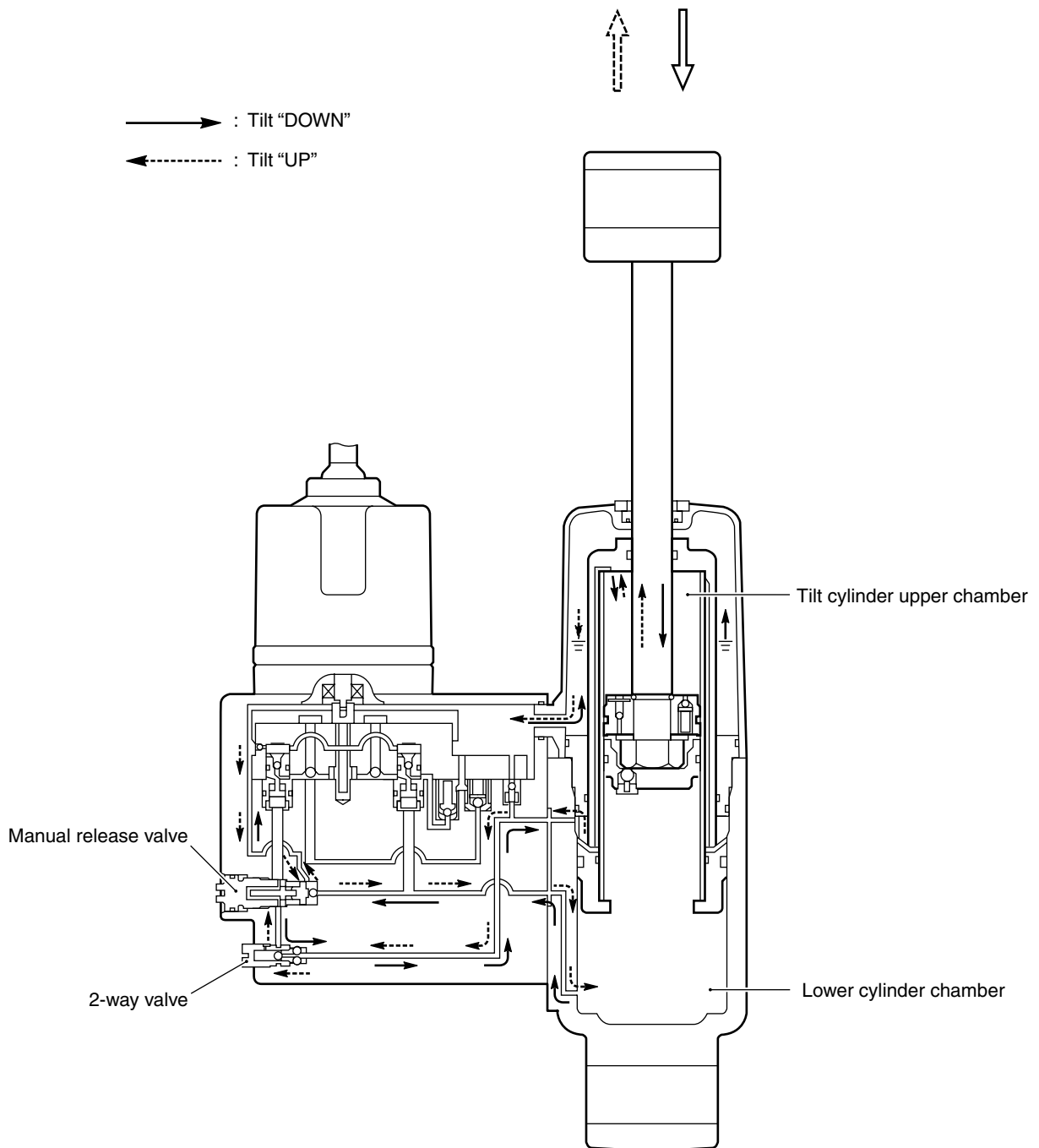

THERMAL VALVE

As temperature goes up, oil pressure will increase and the oil in PTT unit will expand. High oil pressure in the upper cylinder chamber caused by rising of outside temperature will release thermal valve and make the oil flow to reservoir to prevent from damaging of PTT unit.

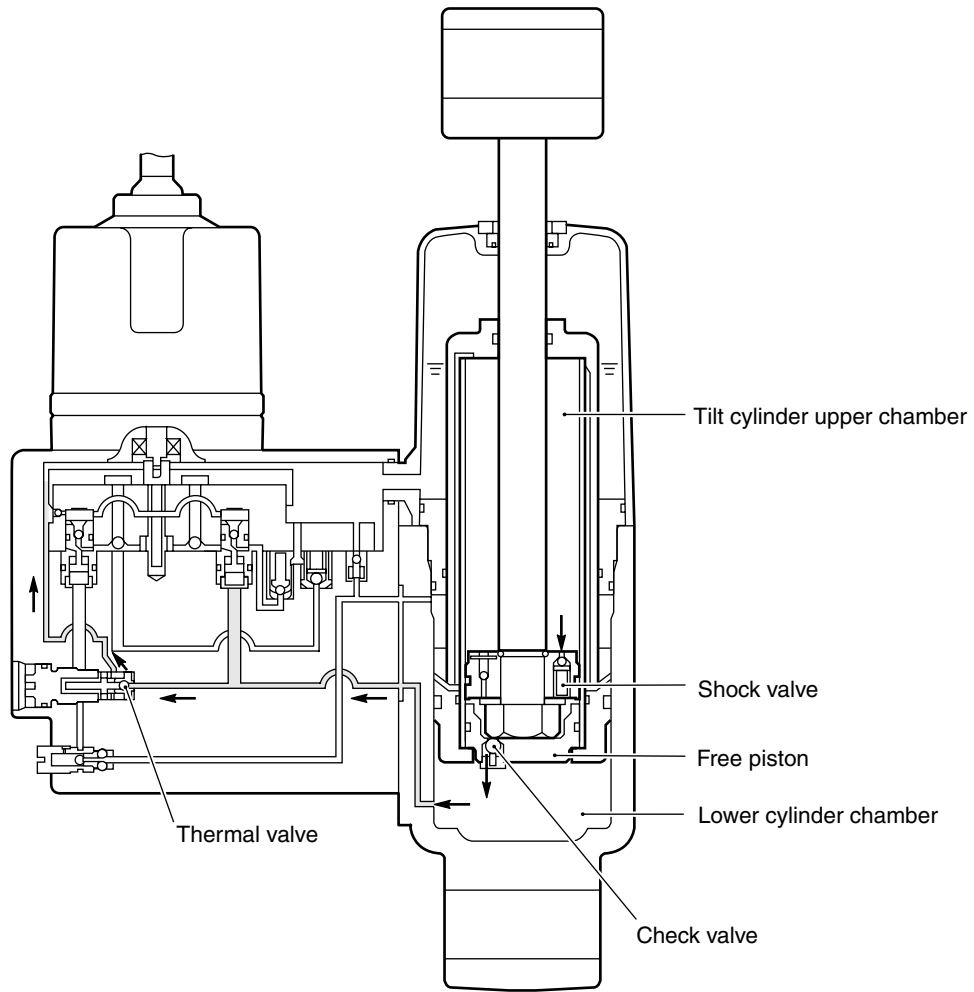

LOWER UNIT

CONTENTS

REMOVAL & DISASSEMBLY	9-2
PINION BEARING	9-7
INSPECTION	9-9
PROPELLER	9-9
GEARCASE	9-9
GEARS	9-10
PROPELLER SHAFT COMPONENTS	9-10
PROPELLER SHAFT BEARING HOUSING	9-10
SHIFT ROD GUIDE HOUSING COMPONENTS	9-11
WATER PUMP AND RELATED ITEMS	9-11
DRIVESHAFT OIL SEAL HOUSING	9-12
DRIVESHAFT	9-12
ASSEMBLY & INSTALLATION	9-13
TRIM TAB	9-23
LOWER UNIT GEARS-SHIMMING AND ADJUSTMENT	9-24

REMOVAL & DISASSEMBLY

⚠ WARNING

Always disconnect the battery cable, before removing lower unit.

1. Shift to "NEUTRAL" position.
2. Remove bolt and trim tab ①.
3. Remove seven (7) bolts ② and separate gearcase ③ from driveshaft housing.

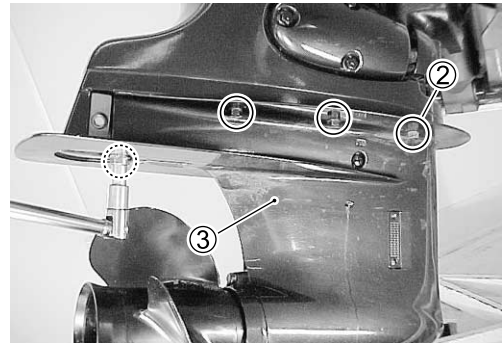
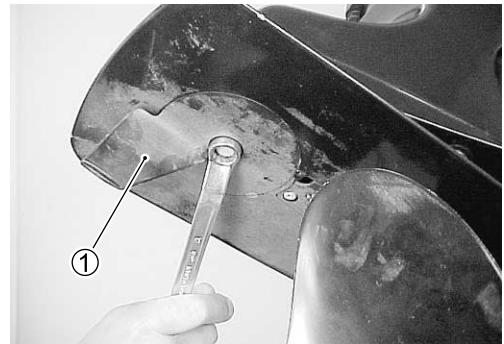

NOTE:

Before gearcase is removed completely, disconnect speedometer pick up tube ④ from gearcase.

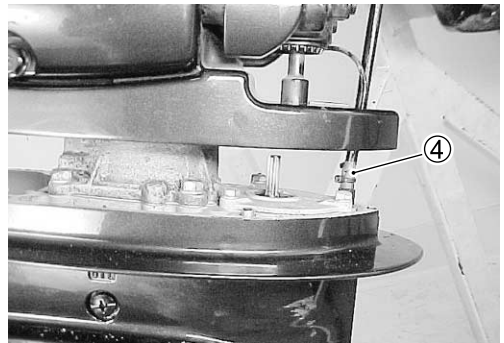

4. Remove clutch rod from clutch shaft (if necessary).

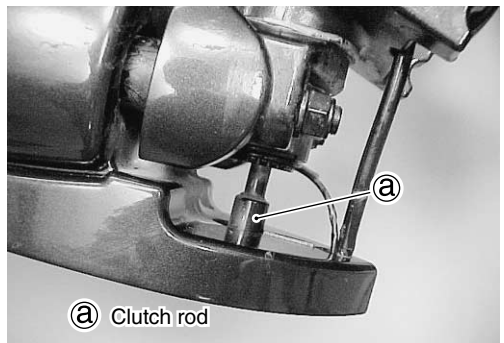

5. Place a drain pan under oil drain plug. Remove oil drain plug ⑥ first then oil level plug ⑤ and allow gear oil to drain. Inspect oil for water, contaminates or metal.

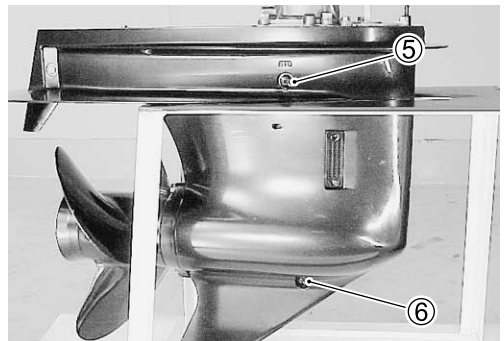

6. Remove cotter pin ⑦ from propeller nut and remove propeller nut ⑧.
7. Remove washer ⑨, spacer ⑩, propeller ⑪, stopper ⑫ and spacer ⑬ from propeller shaft.

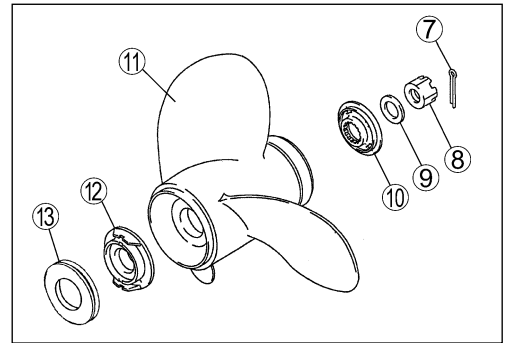

⚠ WARNING

To prevent injury from propeller blades, wear gloves and place a block of wood between the anti-cavitation plate and the propeller blade tips to lock the propeller in place.

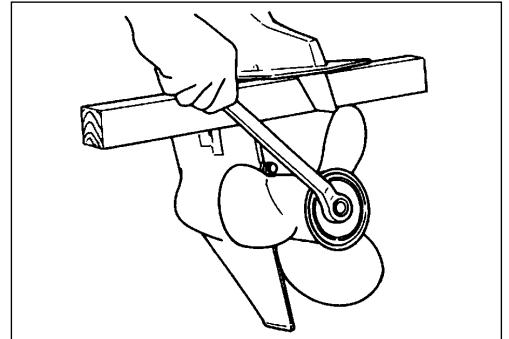

8. Loosen four bolts ①, then remove water pump case ②, impeller ③, impeller key ⑥, pump under plate ④ and dowel pins ⑤.

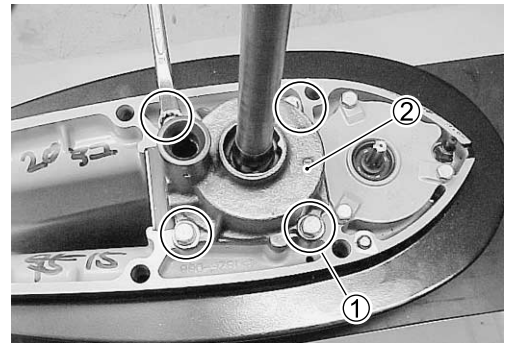

9. Keep impeller key ⑥ for reuse and discard plate gasket.

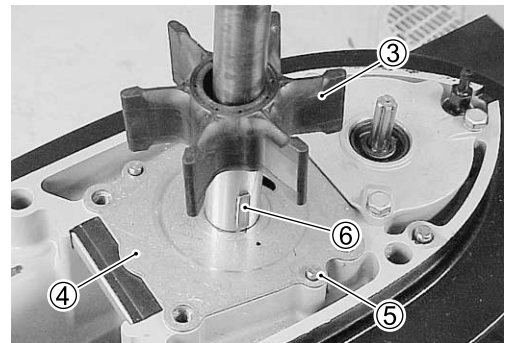

10. Remove three (3) bolts ① and shift rod guide housing assembly ②.

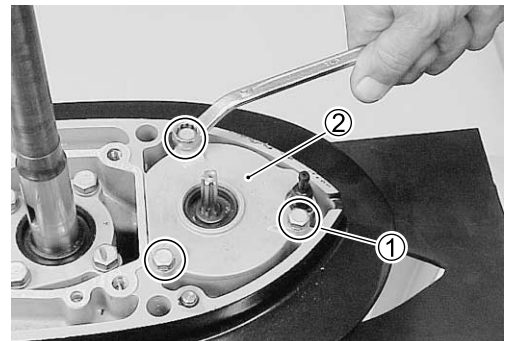

9-4 LOWER UNIT

11. Remove two bolts ① securing propeller shaft bearing housing to gearcase.

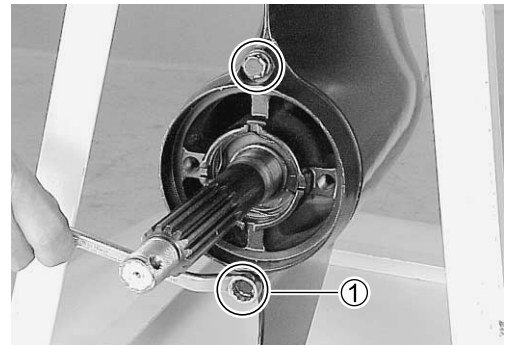

12. Using special tools, draw out propeller shaft bearing housing.
Remove propeller shaft and bearing housing assembly.

TOOL 09930-30104 : Sliding hammer (A)
09930-30161 : Propeller shaft remover (B)

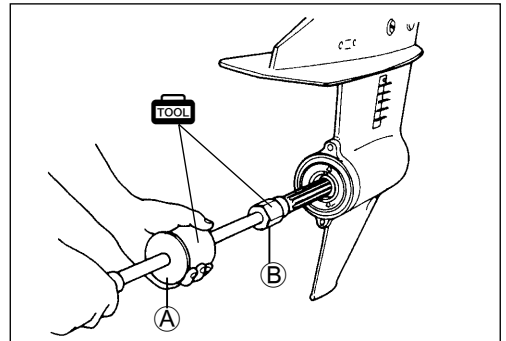

13. Hold pinion nut securely, then fit special tool to the driveshaft and loosen pinion nut.

TOOL 09921-29410 : Driveshaft holder



14. Remove four bolts ① securing driveshaft oil seal housing ②, then remove oil seal housing and pinion shim ③.

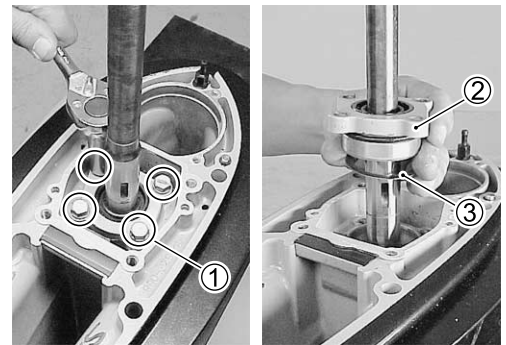

15. Lift out driveshaft assembly ④.
Remove driveshaft collar ⑤, washer ⑥, wave washer ⑦, washer (with tab) ⑧ and washer ⑨ from driveshaft.

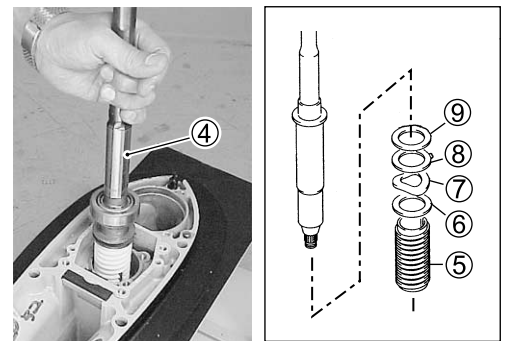

16. Remove pinion gear 1.
Remove forward gear ② (with thrust washer ⑤, back-up shim ④ and bearing ③).

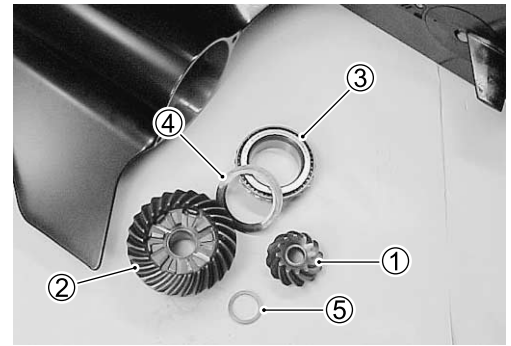

17. Remove three bolts ① securing shift cam housing, then remove shift cam housing ②.
Account for dowel pins.

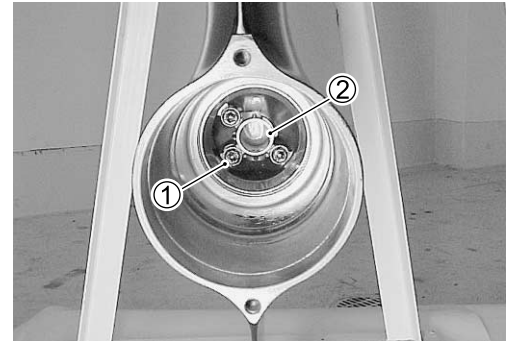

Disassembly of propeller shaft components

1. Slide propeller shaft away from reverse gear ③ and bearing housing assembly ①.
Account for reverse gear back-up shim ② and reverse gear thrust washer ④.

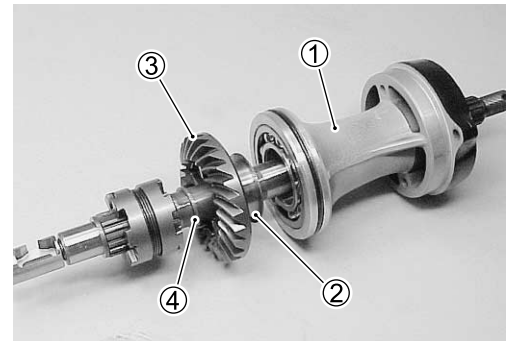

2. Remove horizontal slider ⑤ and forward gear thrust washer ⑥.
3. Remove spring ⑦ from clutch dog shifter.

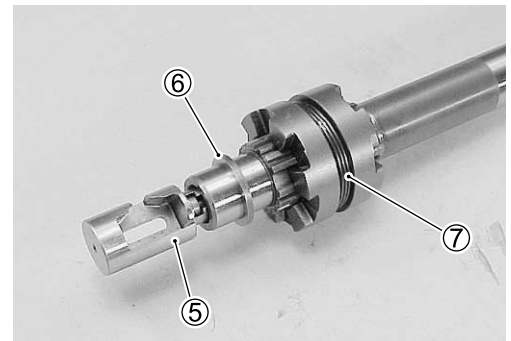

4. Using special tool, push dog pin ⑧ out of clutch dog shifter.

 09922-89810 : Shift pin remover

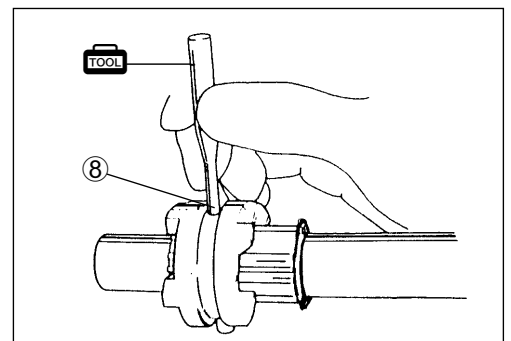

9-6 LOWER UNIT

5. Remove clutch dog shifter ⑨ and connector pin ⑩ from propeller shaft.

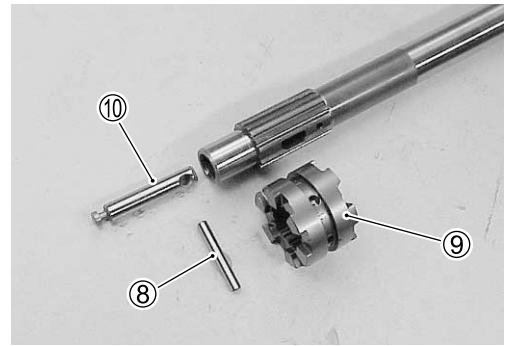

Disassembly of shift rod components

1. Remove circlip ① and washer ②.
2. Slide shift rod ③ out of shift rod guide housing.

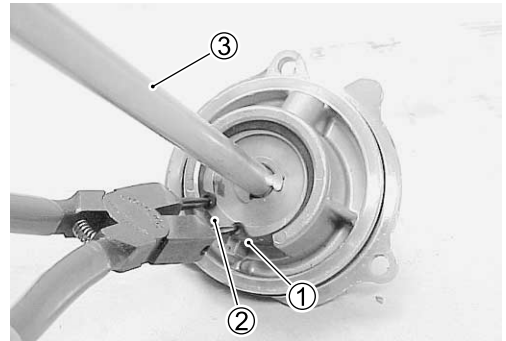

3. Remove detent ball ④ and spring ⑤.

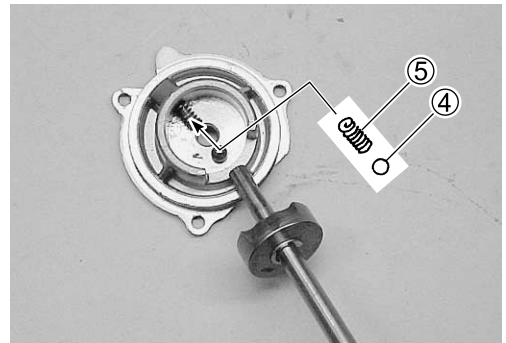

4. Remove pin ⑦ and shifter yoke ⑧.

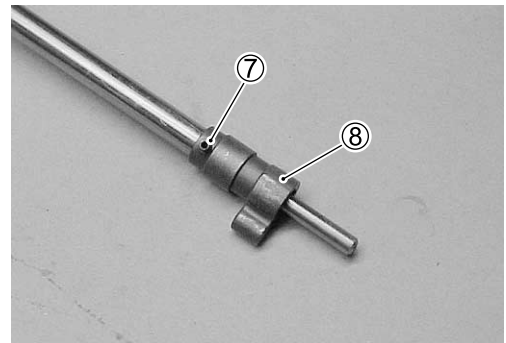

PINION BEARING

Removal / installation is in following procedure.

Removal & Installation Tools

- TOOL** 09951-59910 : Shaft (removal & installation) ①
 09551-39914 : plate ②
 01500-08403 : Bolt ③
 09951-19421 : Attachment ④
 09917-98221 : Spacer ⑤
 09930-30104 : Sliding hammer ⑥

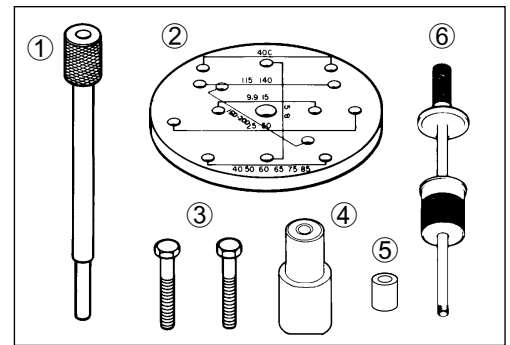

REMOVAL

1. Place attachment ④ inside pinion bearing.
2. Insert shaft ① into attachment ④.
3. Thread sliding hammer ⑥ into top of shaft ①.
4. Put wood block under pinion bearing.
5. Drive pinion bearing out downwards by striking top of shaft ① with sliding hammer ⑥.

CAUTION

- When removing pinion bearing, use care to avoid damaging gearcase.
- Do not re-use pinion bearing once removed. Always use a new pinion bearing.

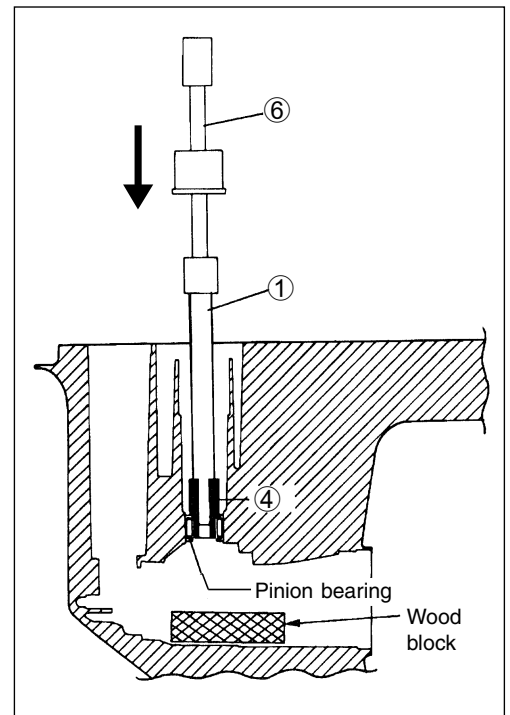

INSTALLATION

CAUTION

Before installing bearing, ensure that inside of gearcase is clean and free of debris.

1. Set shaft ①, plate ②, spacer ⑤, attachment ④ and pinion bearing as shown in figure.
2. Place shaft ① (with pinion bearing on end of shaft) into gearcase.
3. Secure plate ② by tightening bolts ③.
4. Thread sliding hammer ⑥ into top of shaft ①.
5. Drive pinion bearing down into position by gently striking shaft ① until dimension between undersurface of shaft ① shoulder and top surface of plate ② become 3 mm.

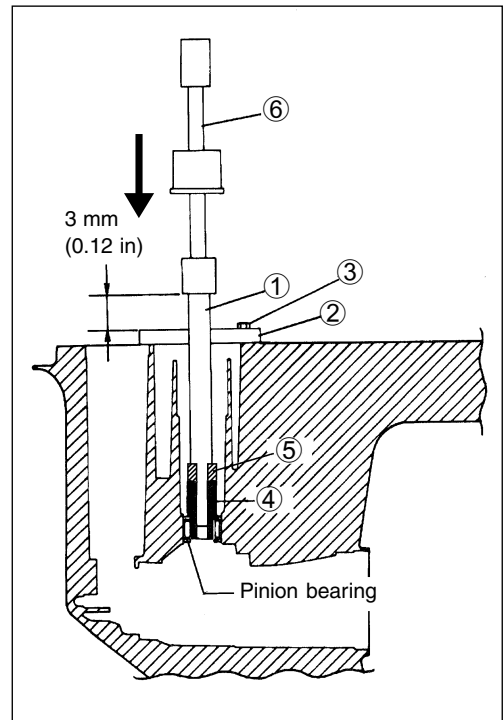
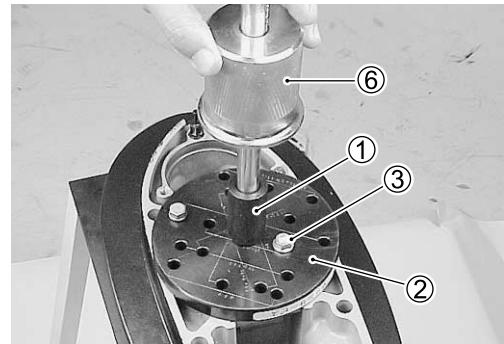

INSPECTION

NOTE:

If excessive wear, cracks, defective or other damage is found on any component, replace component.

NOTE:

Thoroughly wash all metal components with cleaning solvent and dry with compressed air.

⚠ WARNING

Wear safety glasses when using compressed air.

PROPELLER

- Inspect propeller for bent, chipped or broken blades. Replace or repair if necessary.
- Inspect propeller bushing splines for wear or other damage. Replace if necessary.
- Inspect propeller bushing for deterioration or slipping. Replace if necessary.

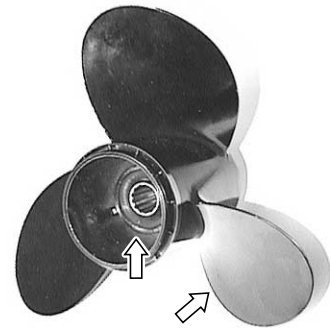

GEARCASE

- Inspect gearcase for cracks or other damage. Replace if necessary.
- Inspect pinion bearing for pitting, rough or other damage. Replace if necessary.

NOTE:

If removal and replacement are required, see "PINION BEARING" section on page 9-7.



GEARS

- Inspect forward, reverse and pinion gear teeth and engaging dogs for excessive wear or other damage. Replace if necessary.
- Inspect forward gear bearing for pitting, rough or other damage. Replace if necessary.



PROPELLER SHAFT COMPONENTS

- Inspect horizontal slider and connector pin for excessive wear or other damage. Replace if necessary.
- Inspect clutch dog shifter for excessive wear, chip or other damage. Replace if necessary.
- Inspect dog pin for bent or other damage. Replace if necessary.
- Inspect propeller shaft / splines for wear, twist or other damage. Replace if necessary.

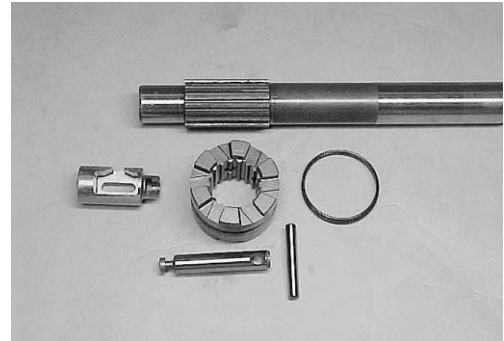

PROPELLER SHAFT BEARING HOUSING

- Inspect housing for cracks or other damage. Replace if necessary.
- Inspect propeller shaft bearings and reverse gear bearing for pitting, rough or other damage. Replace if necessary.
- Inspect oil seals and O-ring for cuts, nicks or tears.



Replacing propeller shaft oil seal

1. Remove retaining ring ① and washer ②.
2. Extract oil seals ③ using oil seal remover.

 **09913-50121 : Oil seal remover**

CAUTION

**Do not re-use oil seal once removed.
Always use a new oil seal.**

3. Apply Water Resistant Grease to inner circumference of housing.
4. Using an oil seal installer, drive two oil seals (one at a time) into housing.
The lipped portion of seal should face towards propeller.
Apply Water Resistant Grease to seal lips.

 **99000-25160 : Water Resistant Grease**

5. Install washer and retaining ring.

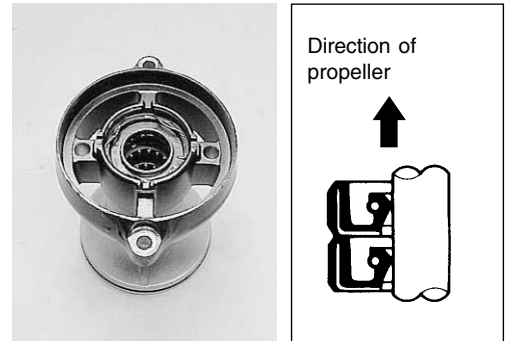
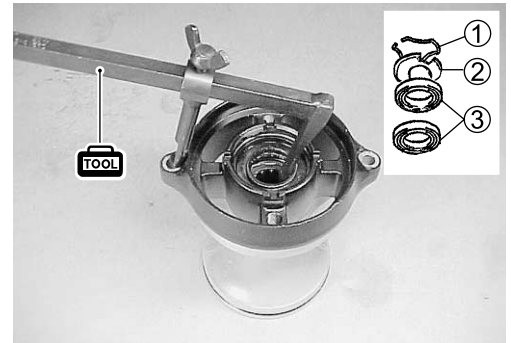

SHIFT ROD GUIDE HOUSING COMPONENTS

- Inspect shift rod guide housing for cracks or other damage. Replace if necessary.
- Inspect shifter yoke for excessive wear or other damage. Replace if necessary.
- Inspect oil seal and O-ring for wear, cuts, nicks or tears.
- Inspect shift rod / splines for excessive wear, twist or other damage. Replace if necessary.
- Inspect detent ball for wear, rough or other damage. Replace if necessary.

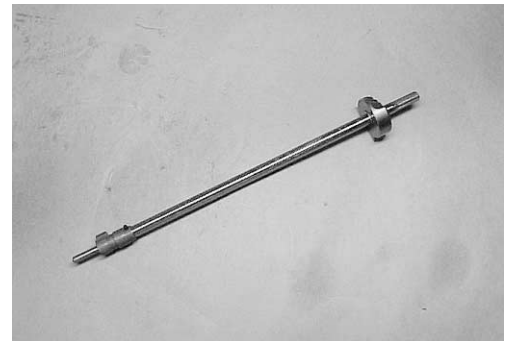

WATER PUMP AND RELATED ITEMS

- Inspect impeller vanes for cuts, cracks, tears or excessive wear. Replace if necessary.
- Inspect pump case and under panel for cracks, distortion or corrosion. Replace if necessary.

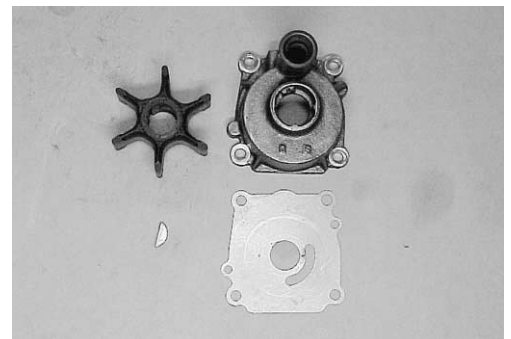

DRIVESHAFT OIL SEAL HOUSING

- Inspect housing for cracks or other damage. Replace if necessary.
- Inspect oil seals and O-ring for wear, cuts, nicks or tears.

Replacing driveshaft oil seal

1. Extract oil seals using oil seal remover.

 **09913-50121 : Oil seal remover**

2. Apply Water Resistant Grease to inner circumference of housing.

 **99000-25160 : Water Resistant Grease**

3. Using an oil seal installer, drive two oil seals (one at a time) into housing.
The lipped portion of seal should face towards water pump case.
Grease inner lips of seal.

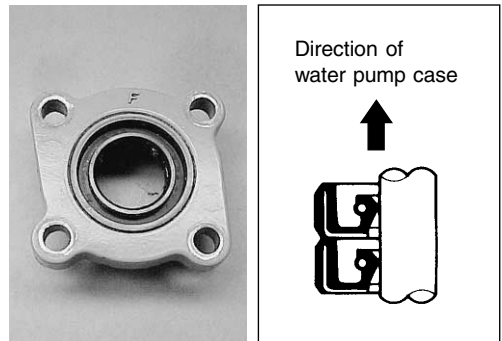
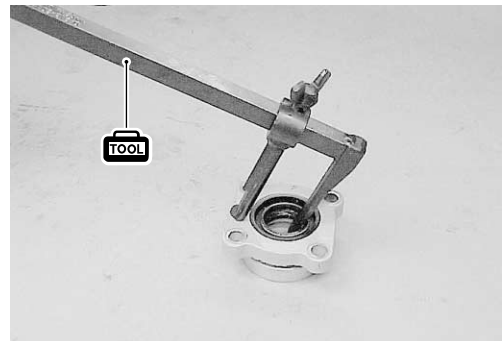

DRIVESHAFT

- Inspect driveshaft / splines for wear, twist or other damage. Replace if necessary.
- Inspect driveshaft bearing for pitting, rough or other damage. Replace if necessary.

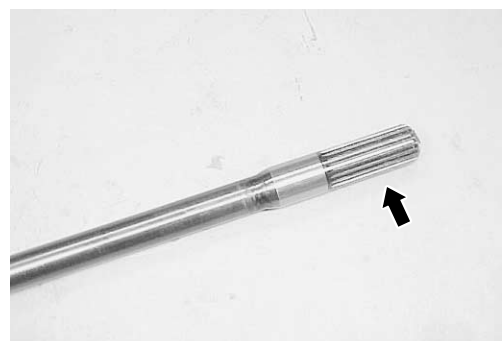

ASSEMBLY & INSTALLATION

Assembly & Installation are reverse order of disassembly with special attention to the following steps.

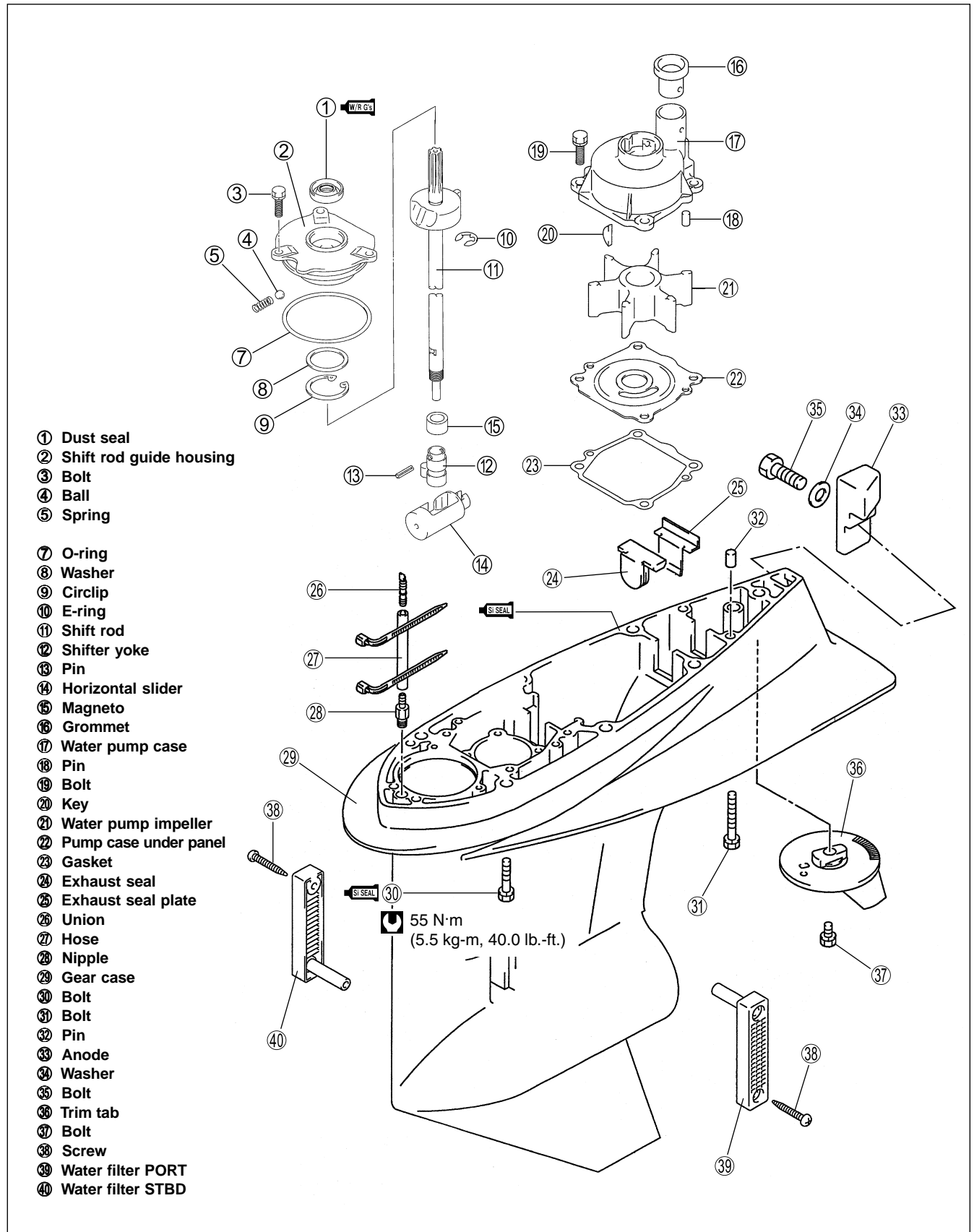

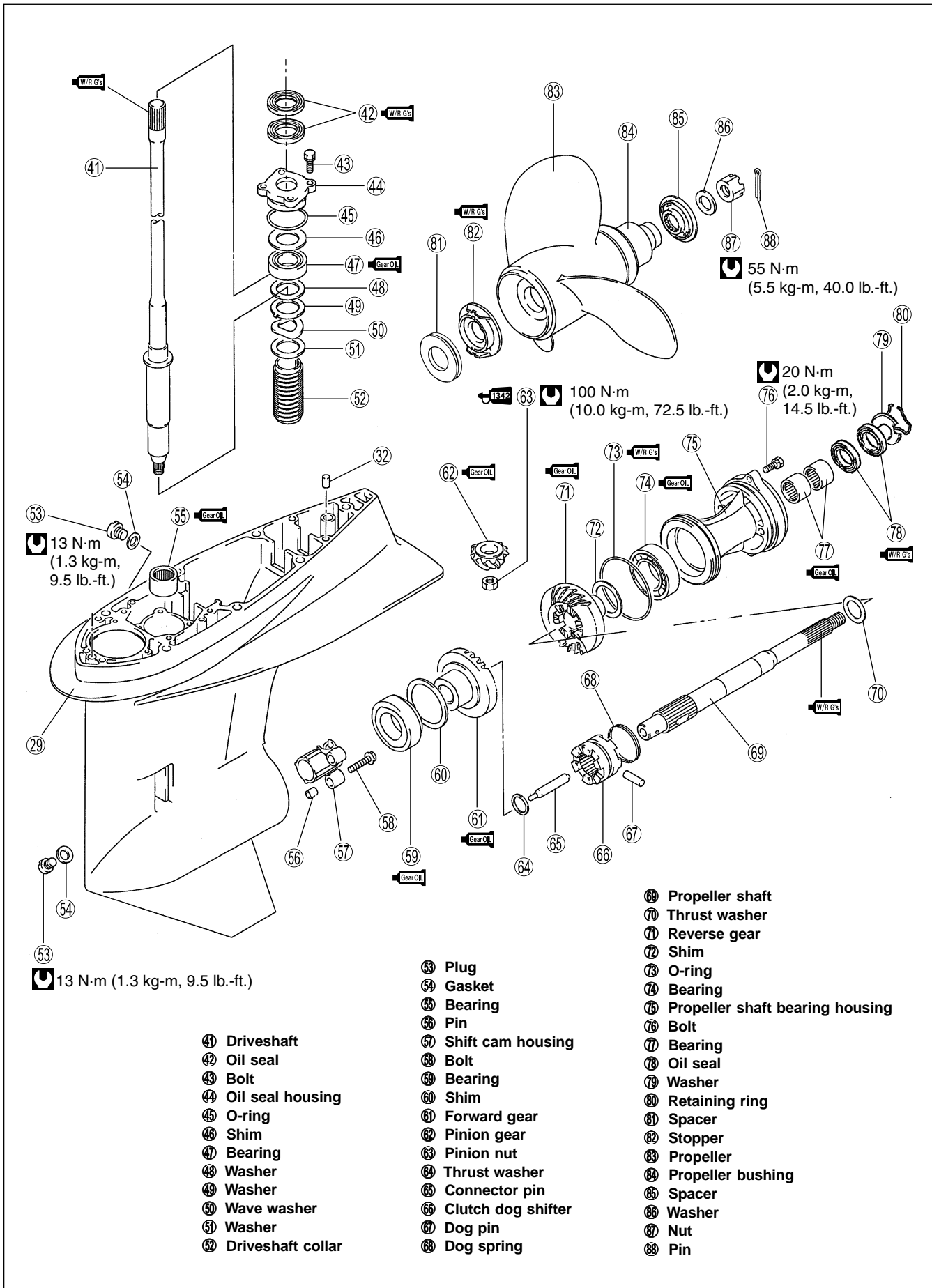

- 41 Driveshaft
- 42 Oil seal
- 43 Bolt
- 44 Oil seal housing
- 45 O-ring
- 46 Shim
- 47 Bearing
- 48 Washer
- 49 Washer
- 50 Wave washer
- 51 Washer
- 52 Driveshaft collar

- 53 Plug
- 54 Gasket
- 55 Bearing
- 56 Pin
- 57 Shift cam housing
- 58 Bolt
- 59 Bearing
- 60 Shim
- 61 Forward gear
- 62 Pinion gear
- 63 Pinion nut
- 64 Thrust washer
- 65 Connector pin
- 66 Clutch dog shifter
- 67 Dog pin
- 68 Dog spring

- 69 Propeller shaft
- 70 Thrust washer
- 71 Reverse gear
- 72 Shim
- 73 O-ring
- 74 Bearing
- 75 Propeller shaft bearing housing
- 76 Bolt
- 77 Bearing
- 78 Oil seal
- 79 Washer
- 80 Retaining ring
- 81 Spacer
- 82 Stopper
- 83 Propeller
- 84 Propeller bushing
- 85 Spacer
- 86 Washer
- 87 Nut
- 88 Pin

CAUTION

- Make sure that all parts used in assembly are clean and lubricated.
 - After assembly, check parts for tightness and smoothness of operation.
 - Before final assembly, be absolutely certain that all gear contact, shim adjustments and tolerances are correct.
- Failure to correctly adjust these areas will result in lower unit damage.
- (See "GEARS SHIMMING AND ADJUSTMENT" section on page 9-24)

SHIFT CAM HOUSING

Install dowel pins ① and shift cam housing ②, then tighten three bolts ③ securely.

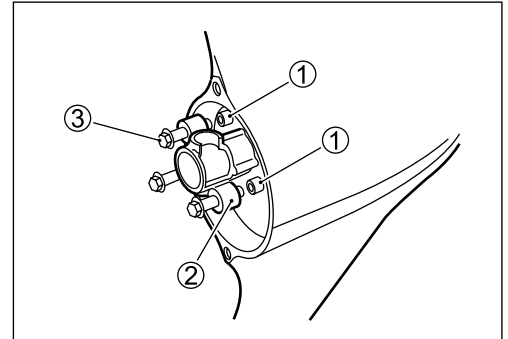
**FORWARD GEAR**

Place forward gear bearing ③ and back-up shim ② in position, then install forward gear ①.

 99000-22540 : Suzuki Outboard Motor Gear Oil

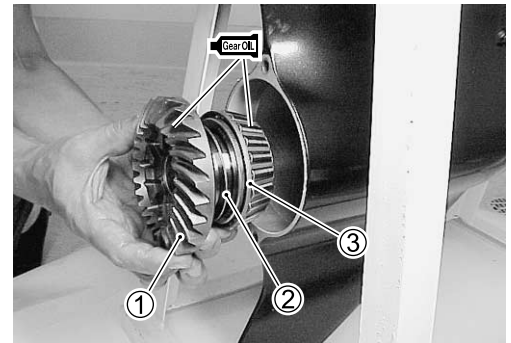
**PINION GEAR**

Place pinion gear in gearcase.

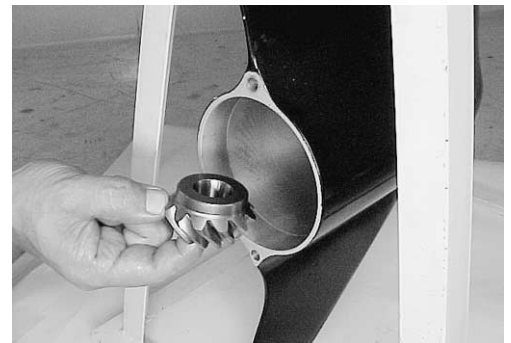

DRIVESHAFT

1. Assemble washer ①, washer (with tab) ②, wave washer ③, washer ④ and driveshaft collar ⑤ to driveshaft.
2. After installing driveshaft collar, fit convex part of collar in concave part of driveshaft by turning collar.

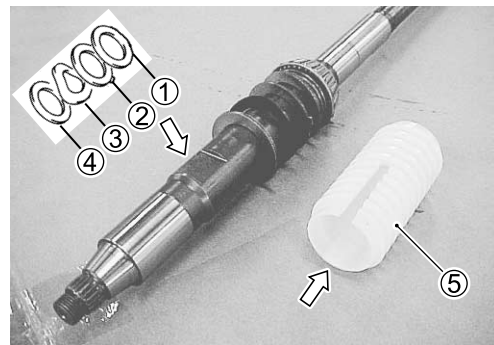

3. Lower driveshaft assembly ⑥ down into gearcase until bottom of shaft protrudes through center of pinion.

NOTE:

Washer tab should be located into groove on gearcase.

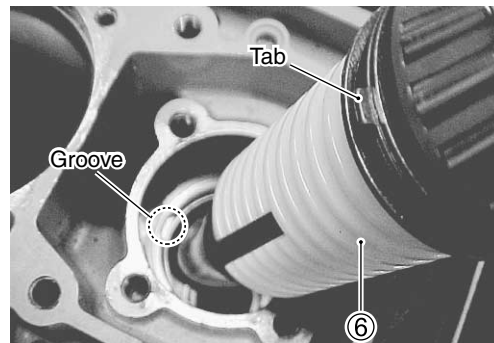

4. Install bearing outer race ⑦ and pinion shim ⑧ to driveshaft.

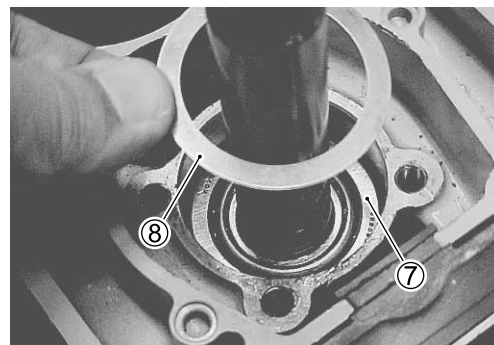

DRIVESHAFT OIL SEAL HOUSING

1. Apply Water Resistant Grease to driveshaft oil seal.

 **99000-25160 : Water Resistant Grease**

2. Apply Water Resistant Grease to O-ring, then install O-ring into groove on driveshaft oil seal housing.

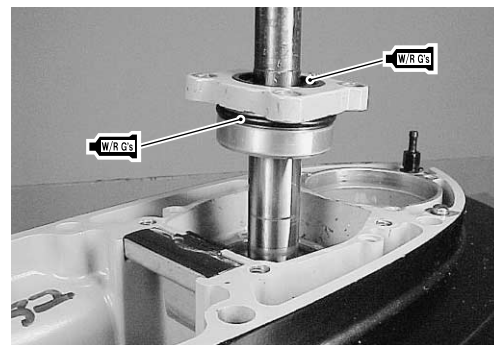



3. Install driveshaft oil seal housing on gearcase, then tighten four bolts securely.



PINION NUT

Apply Thread Lock 1342 to threads of pinion nut, then tighten nut to specified torque.

 Pinion nut : 100 N·m (10.0 kg·m, 72.5 lb.-ft.)

 99000-32050 : Thread Lock 1342

 09921-29410 : Drive shaft holder

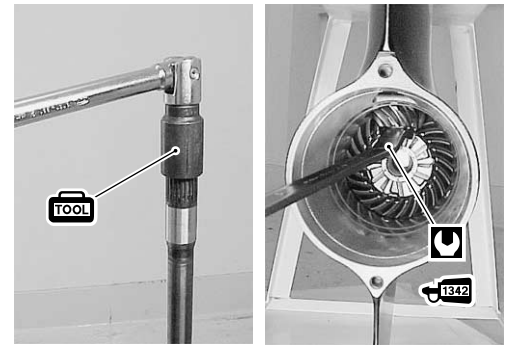
**CHECKING DRIVESHAFT THRUST PLAY**

Before installing reverse gear, driveshaft thrust play should be checked.

(See CHECKING DRIVESHAFT THRUST PLAY section on page 9-27)

 09951-09511 : Gear adjusting gauge

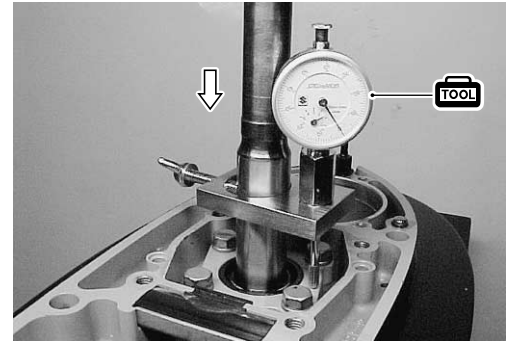
**PROPELLER SHAFT**

1. Slide clutch dog shifter ② onto propeller shaft ①.

NOTE:

For correct installation, side of clutch dog shifter which should face towards reverse gear is marked with letter "R".

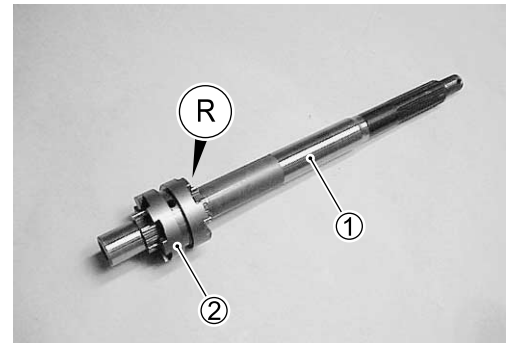

2. Insert connector pin ③ into propeller shaft.

3. Align holes in clutch dog shifter ② and connector pin ③, then slide dog pin ④ through them.

4. Install dog spring ⑤, ensuring that it fits snugly into groove on clutch dog shifter.

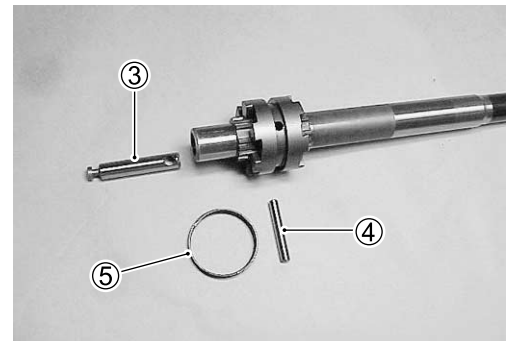

PROPELLER SHAFT / BEARING HOUSING

1. Assemble propeller shaft in following sequence :
 Forward thrust washer ⑤, Reverse thrust washer ①,
 Reverse gear ②, Reverse gear back-up shim ③,
 Propeller shaft housing ④.

 **99000-25160 : Water Resistant Grease**

 **99000-22540 : Suzuki Outboard Motor Gear Oil**

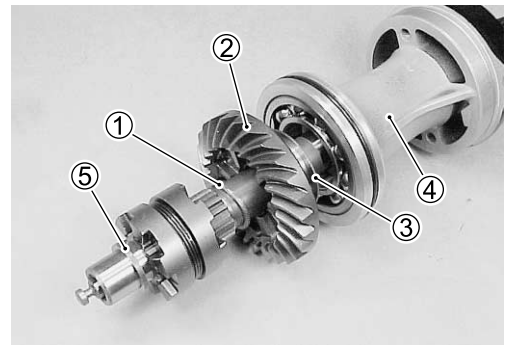

2. Assemble horizontal slider ⑥ to connector pin.

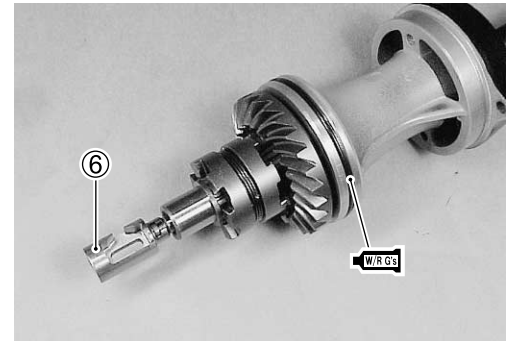

3. Using special tools, install propeller shaft and housing assembly in gear case.

 **09922-59410 : Propeller shaft housing installer**
09922-59420 : Housing Installer Handle

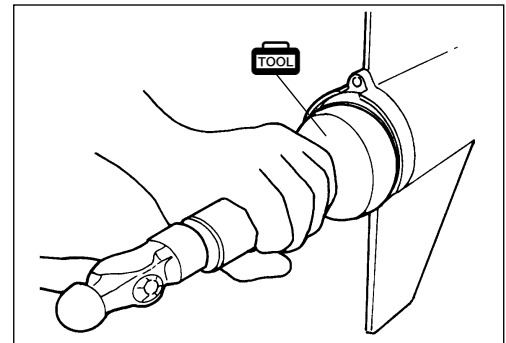

4. When housing is fully seated, tighten two bolts to specified torque.

 **Bearing housing bolt : 20 N · m (2.0 kg-m, 14.5 lb.-ft.)**

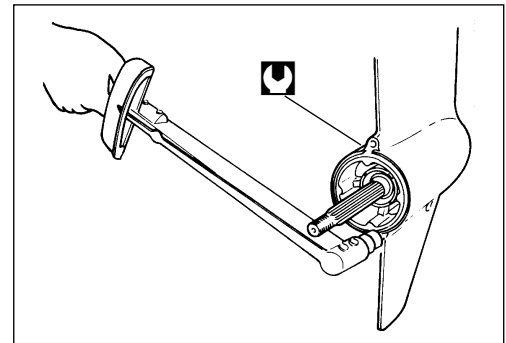

RECHECKING DRIVESHAFT THRUST PLAY

Recheck driveshaft thrust play.

This should not be less than previously checked on page 9-17.
 (See “RECHECKING DRIVESHAFT THRUST PLAY” section on page 9-27.)

 **09951-09511 : Gear adjusting gauge**

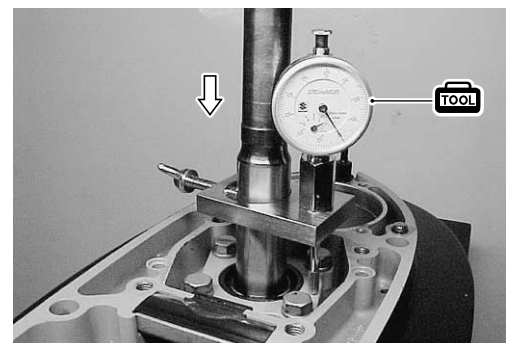

CHECKING PROPELLER SHAFT THRUST PLAY

See page 9-28.

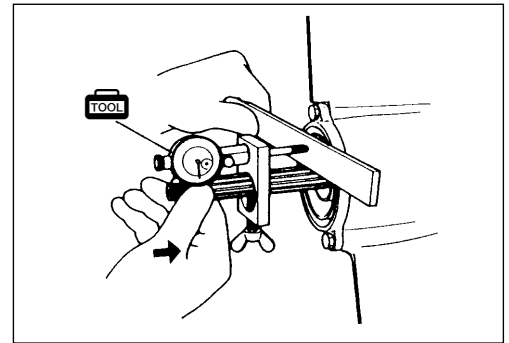

SHIFT ROD GUIDE HOUSING

1. Install spring ② and detent ball ③ into shift rod guide housing.
2. Apply Water Resistant Grease to shift rod oil seal.

 **99000-25160 : Water Resistant Grease**

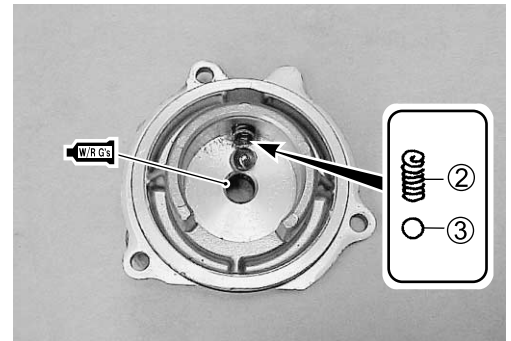

3. Install shift rod ④ and washer ⑤ into the shift rod guide housing ⑥, then secure it with snap ring ⑦.

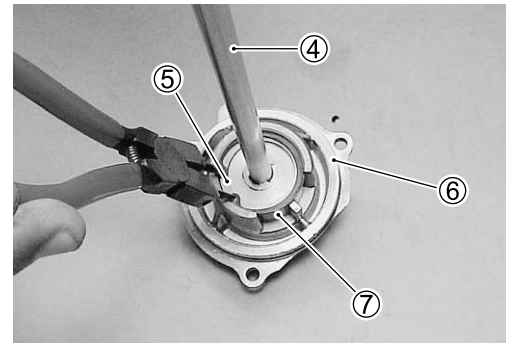

NOTE:

Before install shift rod guide housing assembly, be sure to put horizontal slider in neutral position.

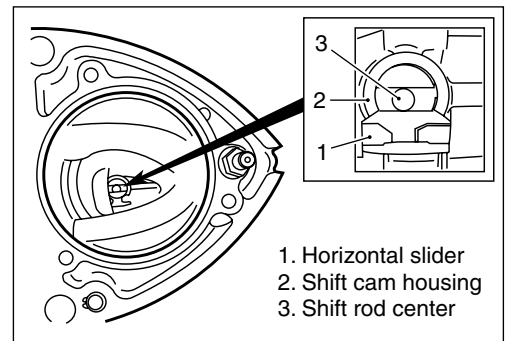

4. Apply Water Resistant Grease to O-ring.

NOTE:

Before install shift rod guide housing assembly, bring shifter yoke to neutral position by turning shift rod.

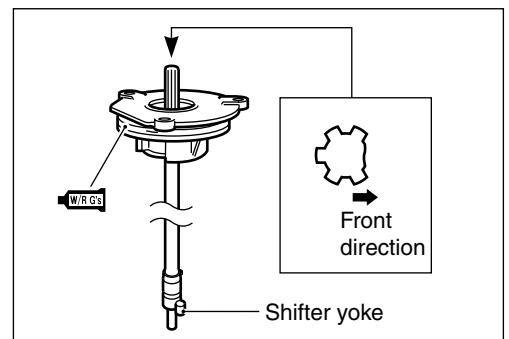

5. Install shift rod guide housing assembly by aligning shifter yoke with groove in horizontal slider, then tighten three housing bolts securely.
6. Turn shift rod from neutral position to forward and reverse position to check proper gear engagement.

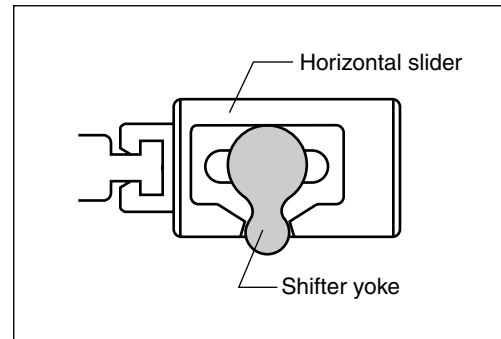
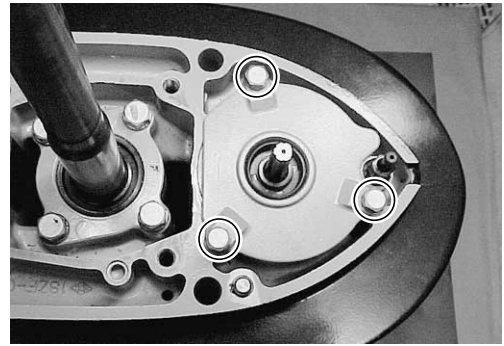

LEAKAGE CHECK

Check for leakage of oil seal and O-ring when applying air pressure inside of gearcase.

 **09950-69512 : Oil leakage tester**
: Hand air pump

Procedure

1. Install oil leakage tester into oil level hole.
2. Connect a hand air pump to oil leakage tester.
3. While rotate driveshaft and propeller shaft clockwise several times, apply specified pressure for leakage test.

NOTE:

Apply low initial pressure of 20 – 40 kpa, (0.2 – 0.4 kg/cm², 2.8 – 5.7 psi) first, then apply specified pressure.

Leakage test pressure : 100 kPa (1.0 kg/cm², 14.2 psi)

CAUTION

Do not exceed pressure of 110 kPa (1.1kg/cm², 15.6 psi) or damage to oil seals will result.

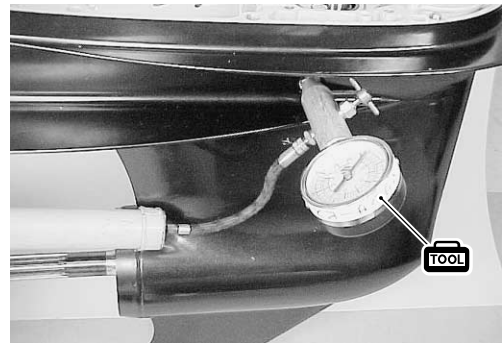

4. Once stabilized, pressure should remain steady for at least 5 min.
If pressure does not fall, sealing performance is correct.

WATER PUMP

1. Place dowel pins ①, under panel gasket ② and under panel ③ into position.
2. Insert key ④ in driveshaft and slide impeller ⑤ onto driveshaft, ensuring that key and keyway are aligned.

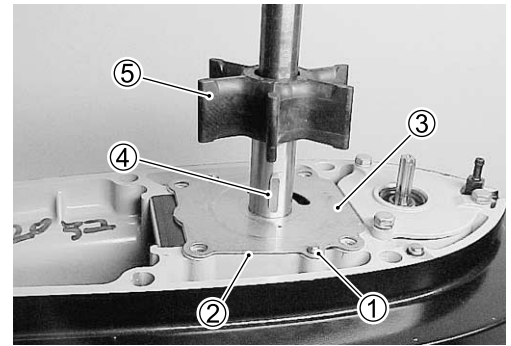

3. Install pump case ⑥ while rotating driveshaft clockwise to flex impeller vanes in correct direction.
4. Tighten four pump case bolts to specified torque.

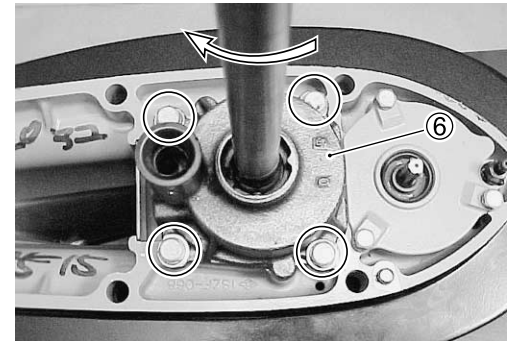

 **Pump case bolt : 20 N·m (2.0 kg-m, 14.5 lb.-ft.)**

PROPELLER INSTALLATION

1. Install spacer ① and propeller stopper ② onto propeller shaft, then slide on propeller ③.
2. Fit spacer ④, washer ⑤ and nut ⑥, then tighten nut to specified torque.

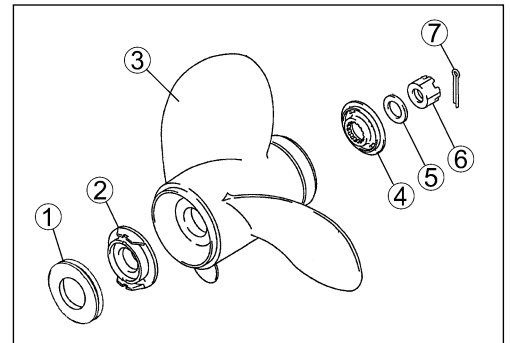

 **Propeller nut : 55 N·m (5.5 kg-m, 40.0 lb.-ft.)**

3. Push cotter pin ⑦ through nut and shaft, then bend to secure.

LOWER UNIT INSTALLATION

1. Apply clutch rod splines with Water Resistant Grease, then install clutch rod ① by aligning clutch rod splines with splines in clutch shaft.

 **99000-25160 : Water Resistant Grease**

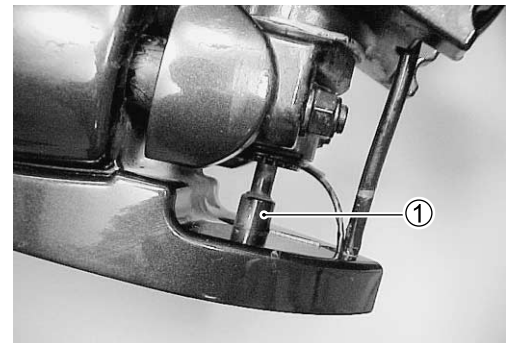

2. Ensure that shift rod ② is at neutral position.

NOTE:

Before install lower unit assembly, bring shift to neutral position by turning shift rod.

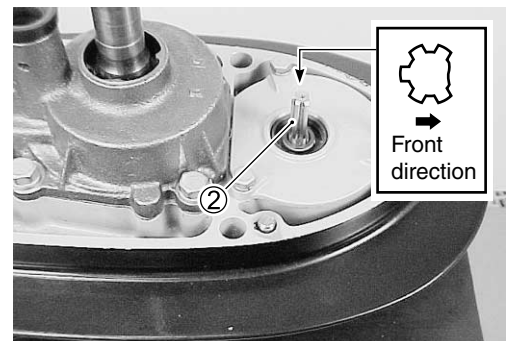

9-22 LOWER UNIT

3. Insert two dowel pins ③.
4. Apply driveshaft splines and shift rod splines with Water Resistant Grease.
5. Apply Suzuki Silicone Seal lightly to mating surfaces of gearcase and driveshaft housing.

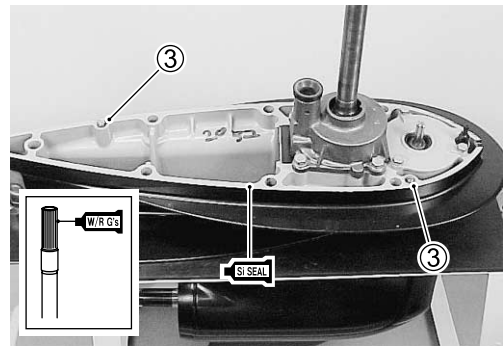

6. Set clutch control lever ④ at neutral position, then slide lower unit ⑤ into place, ensuring that top of driveshaft engages properly with countershaft and that water tube locates in water pump case outlet.

NOTE:

In order for shift rod splines and clutch rod splines to be aligned correctly, clutch rod may need to be turned slightly right or left.

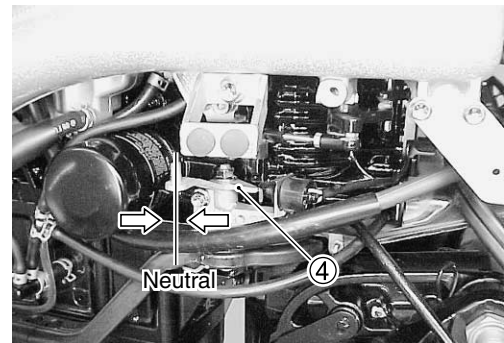

7. Apply Silicone Seal to seven gearcase bolts ⑥ and tighten them to specified torque.

 **Gearcase bolt : 55 N · m (5.5 kg-m, 40.0 lb.-ft.)**

 **99000-25160 : Water Resistant Grease**

 **99000-31120 : Suzuki Silicone Seal**

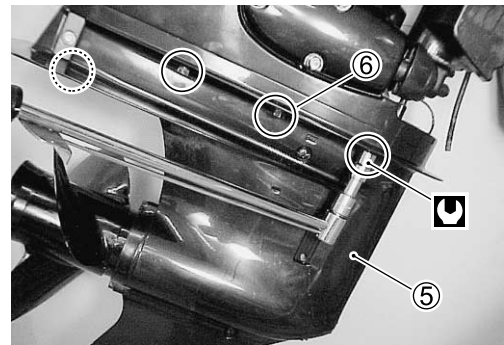

8. Move clutch control lever ④ to forward and reverse positions from neutral position to check proper gear engagement.

GEAR OIL

Fill gearcase with specified gear oil.

(See "PERIODIC MAINTENANCE / GEAR OIL" section on page 2-6)

 **99000-22540 : Suzuki Outboard Motor Gear Oil**

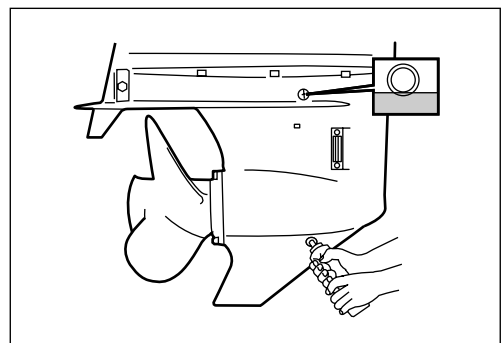

TRIM TAB

Trim tab counteracts or minimizes propeller torque “pull” felt through steering system.

If steering is pulled to starboard or port side, adjust trim tab with following procedure :

Adjusting

1. Loosen bolt of trim tab.
2. Change direction of trim tab.
 - To compensate for a veer to starboard, set trailing edge of tab to the right (as viewed from behind).
 - To compensate for a veer to port, set trailing edge of tab to the left.
3. Tighten bolt of trim tab.
4. Test ride boat and repeat procedure 1–3 to set trim tab in the best position.

With a properly adjusted trim tab, steering should be neutral and there should be no tendency for steering to be pulled to either port or starboard.

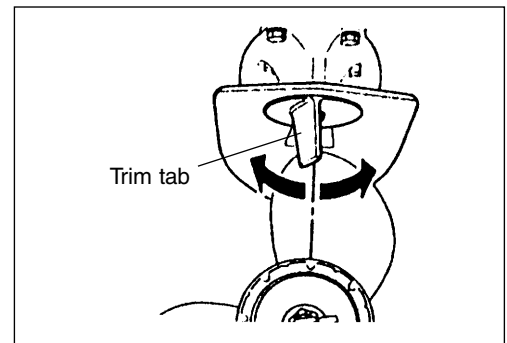
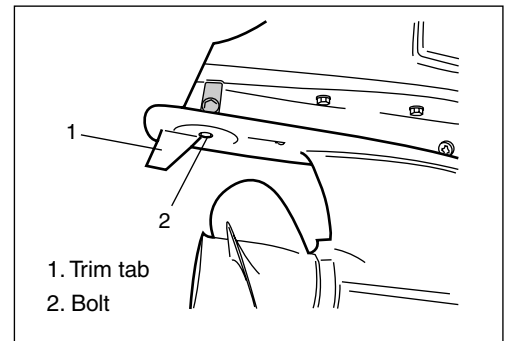

LOWER UNIT GEARS- SHIMMING AND ADJUSTMENT

If lower unit has been rebuilt or has had components replaced, shimming for correct gear contact and backlash will have to be adjusted to ensure smooth, reliable operation of gears.

Shim / Washer & Mounting position

	Numerical index / item	Available thickness (mm)	Design specification Thickness (mm)
①	Pinion gear back up shim	0.60, 0.65, 0.70, 0.75, 0.80, 0.85, 0.90, 0.95, 1.00, 1.05, 1.10, 1.15	1.0
②	Forward gear back up shim	0.45, 0.50, 0.55, 0.60, 0.65, 0.70, 0.75, 0.80, 0.85, 0.90	1.0
③	Forward gear thrust washer	3.0	3.0
④	Reverse gear thrust washer	0.9, 1.0, 1.2, 1.3, 1.4, 1.6	2.2
⑤	Reverse gear back up shim	1.0, 1.1, 1.2, 1.3, 1.4, 1.5, 1.6	1.5

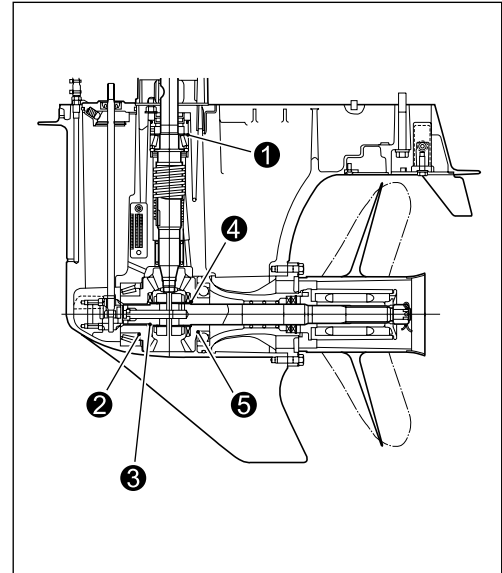

PINION GEAR BACK-UP SHIM ADJUSTMENT

1. Position shimming gauge (A) horizontally in a vise and tighten vise securely.

TOOL 09951-09010 : Shimming gauge

2. Assemble bearing outer race (1), back-up shim (2) and driveshaft oil seal housing (3) to driveshaft.

NOTE:

Use a thinner pinion back-up shim (2) than the standard shim so that a clearance (B) exists.

3. Insert driveshaft through shimming gauge (A) opening and then install pinion gear (4) and nut (5) to driveshaft, tighten pinion nut.

Pinion nut : 100 N·m (10.0 kg-m, 72.5 lb.-ft.)

4. Install oil seal housing (3) to shimming gauge (A) with bolts (6).

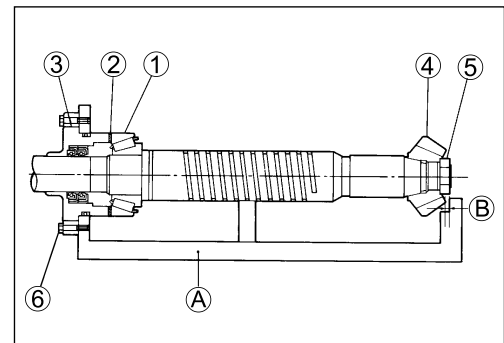

5. Depress and hold driveshaft so that driveshaft bearing is firmly seated in bearing outer race.
6. Hold driveshaft against oil seal housing ③ while measuring clearance ④ between gauge and flat edge of pinion gear ④ with thickness gauge, measured clearance plus shim ② is the total shim thickness to be used in gear housing reassembly for correct pinion gear position.

FORWARD GEAR BACK-UP SHIM ADJUSTMENT

Follow the procedure below to adjust forward gear / pinion gear.

Step to prior to adjustment

1. Correctly assemble driveshaft oil seal housing, driveshaft, forward gear, pinion gear and related components. (See page 9-15 to 9-17)
Do not install reverse gear at this time.
2. Tighten pinion nut to specified torque.

 **Pinion nut : 100 N·m (10.0 kg·m, 72.5 lb.-ft.)**

Checking driveshaft thrust play

1. Affix gear adjusting gauge to drive shaft.

 **09951-09511 : Gear adjusting gauge**

2. To check driveshaft thrust play, push forward gear inward and fix it by hand.
Slowly push driveshaft downward, then read maximum play.

Driveshaft thrust play:
Approx. 0.4 – 0.6 mm (0.016 – 0.023 in.)

If thrust play is larger than the specified, thickness of forward gear back-up shim must be increased.
If thrust play is smaller, forward gear back-up shim thickness must be decreased.

Checking and adjusting tooth contact pattern (Pinion and Forward gear)

Check tooth contact pattern by using following procedure :

1. To assess tooth contact, apply a light coat of Prussian Blue on convex surface of forward gear.

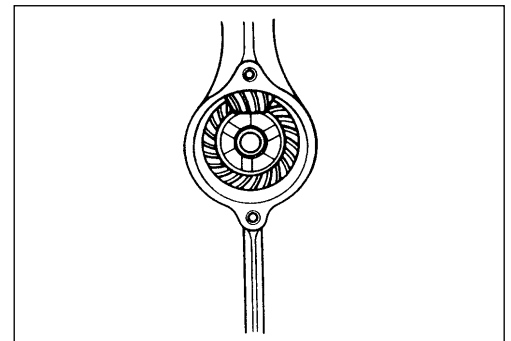
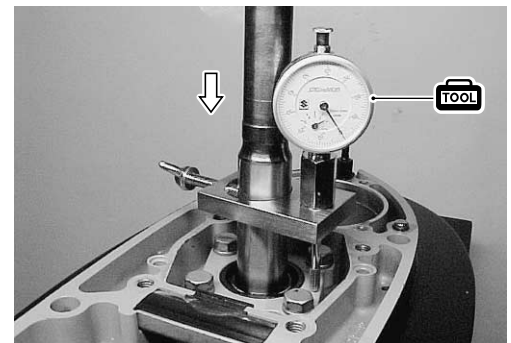
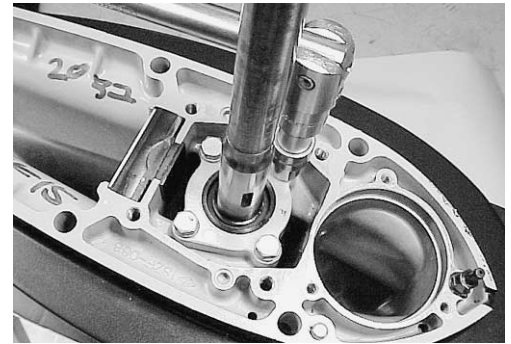

2. Install propeller shaft and housing assembly (minus reverse gear and internal components).
3. Push propeller shaft inward and hold in position.
4. Using driveshaft holder, rotate driveshaft 5 - 6 times.

 **09921-29410 : Driveshaft holder**

5. Carefully pull out propeller shaft and housing to check tooth contact pattern.

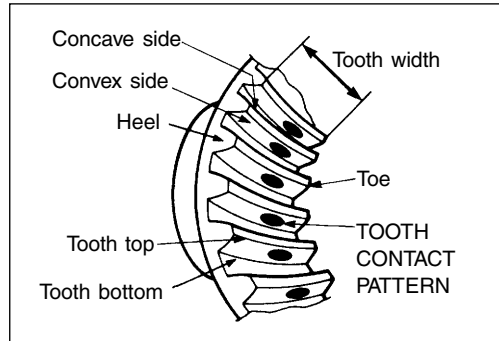
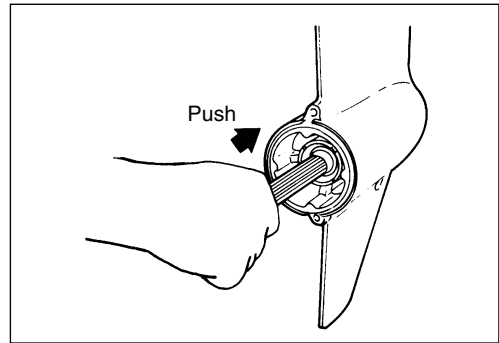

Optimum tooth contact

Optimum tooth contact is shown at right.
A shim adjustment may be necessary to obtain this contact pattern.

CAUTION

Backlash of gear should be checked when increasing or decreasing thickness of shim to adjust tooth contact.

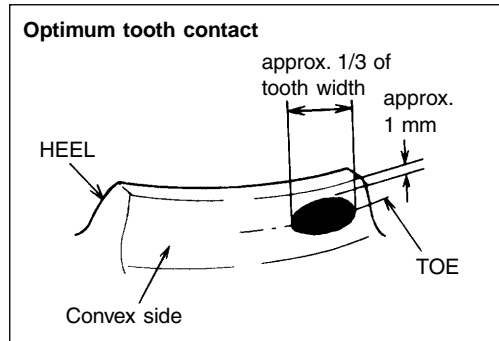

Example (1)

Incorrect topside toe contact :
Correction measures :

- Decrease thickness of forward gear shim.
- Slightly increase pinion gear shim thickness.

CAUTION

Do not set tooth contact in this position (top side toe contact). Damage and chipping of forward and pinion gear may result.

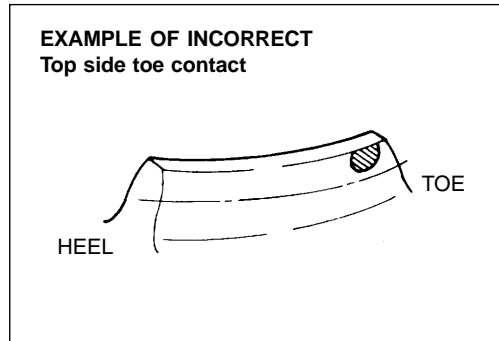

Example (2)

Incorrect bottom side toe contact :
Correction measures :

- Increase thickness of forward gear shim.
- Slightly decrease pinion gear shim thickness.

CAUTION

Do not set tooth contact in this position (bottom side toe contact). Chipping of pinion gear may result.

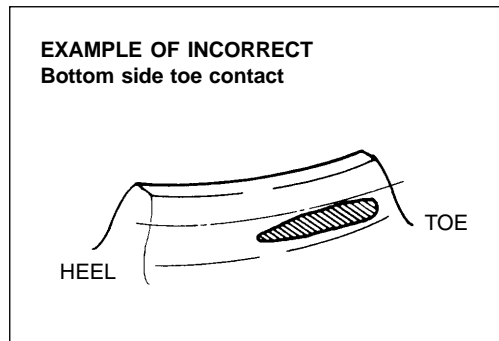

CHECKING DRIVESHAFT THRUST PLAY

After obtaining optimum tooth contact, driveshaft thrust play should be measured.

1. Affix gear adjusting gauge to driveshaft.

 **09951-09511 : Gear adjusting gauge**

2. Slowly push driveshaft downward and read maximum play. Designate this amount of play as (A).

Driveshaft thrust play :

Approx. 0.4 – 0.6 mm (0.016 – 0.023 in.)

NOTE:

Driveshaft thrust play (A) should be known to adjust reverse gear shim.

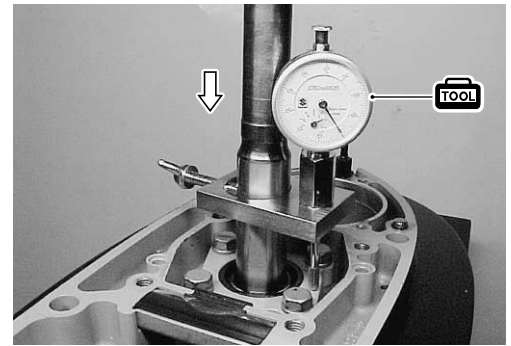
**RECHECKING DRIVESHAFT THRUST PLAY****(Reverse gear back-up shim adjustment)**

1. After adjusting forward gear tooth contact pattern, correctly assemble propeller shaft, housing assembly, reverse gear and related components (See page 9-17 to 9-18).
2. Install sliding hammer (A) and remover (B) onto propeller shaft and strike a few gentle outward taps.

 **09930-30161 : Propeller shaft remover – (B)**

09930-30104 : Sliding hammer – (A)

3. Affix gear adjusting gauge to driveshaft.

 **09951-09511 : Gear adjusting gauge**

4. Slowly push driveshaft downward and read maximum play. Designate this measurement as play (B).
5. Compare play (B) to play (A) (page 9-27).
6. Reverse gear back-up shim adjustment is correct if (B) is equal to (A).

If (B) is less than (A), reduce reverse gear back-up shim thickness.

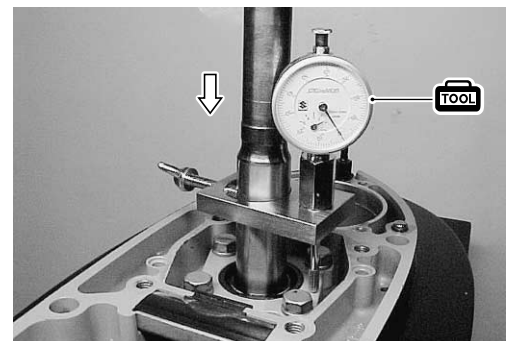
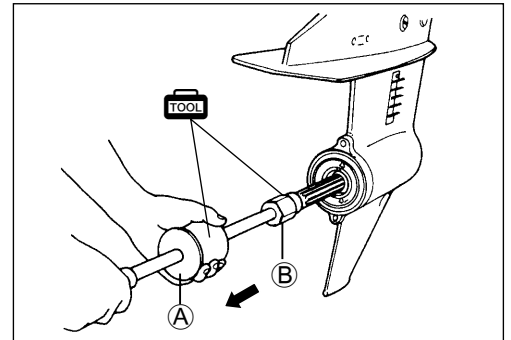

CHECKING PROPELLER SHAFT THRUST PLAY

After adjusting all gear positions, measure propeller shaft thrust play. If not within following specification, a shim adjustment is required.

**Propeller shaft thrust play : 0.2 – 0.4 mm
(0.01 – 0.02 in.)**

NOTE:

Maintain forward gear thrust washer at standard thickness (3.0 mm) and adjust only reverse gear thrust washer with shim.

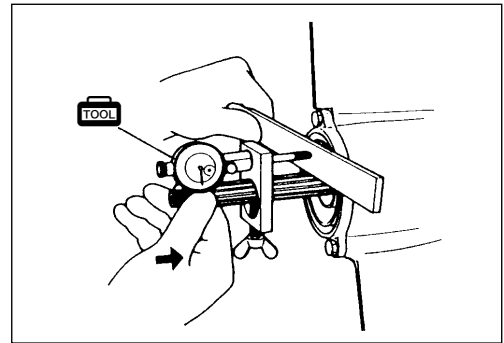

Measurement step :

1. Affix gear adjusting gauge to propeller shaft.

 **09951-09511 : Gear adjusting gauge**

2. Slowly push propeller shaft inward.
3. Hold shaft in and set dial gauge pointer to zero.
4. Slowly pull propeller shaft outward and read maximum thrust play.

If measurement is more than specification, increase reverse gear thrust washer thickness.

If measurement is less than specification, reduce reverse gear thrust washer thickness.

WIRE / HOSE ROUTING

CONTENTS

WIRING DIAGRAM	10-2
WIRE ROUTING	10-3
FUEL / WATER HOSE ROUTING	10-8

WIRING DIAGRAM

DF90T / DF115T

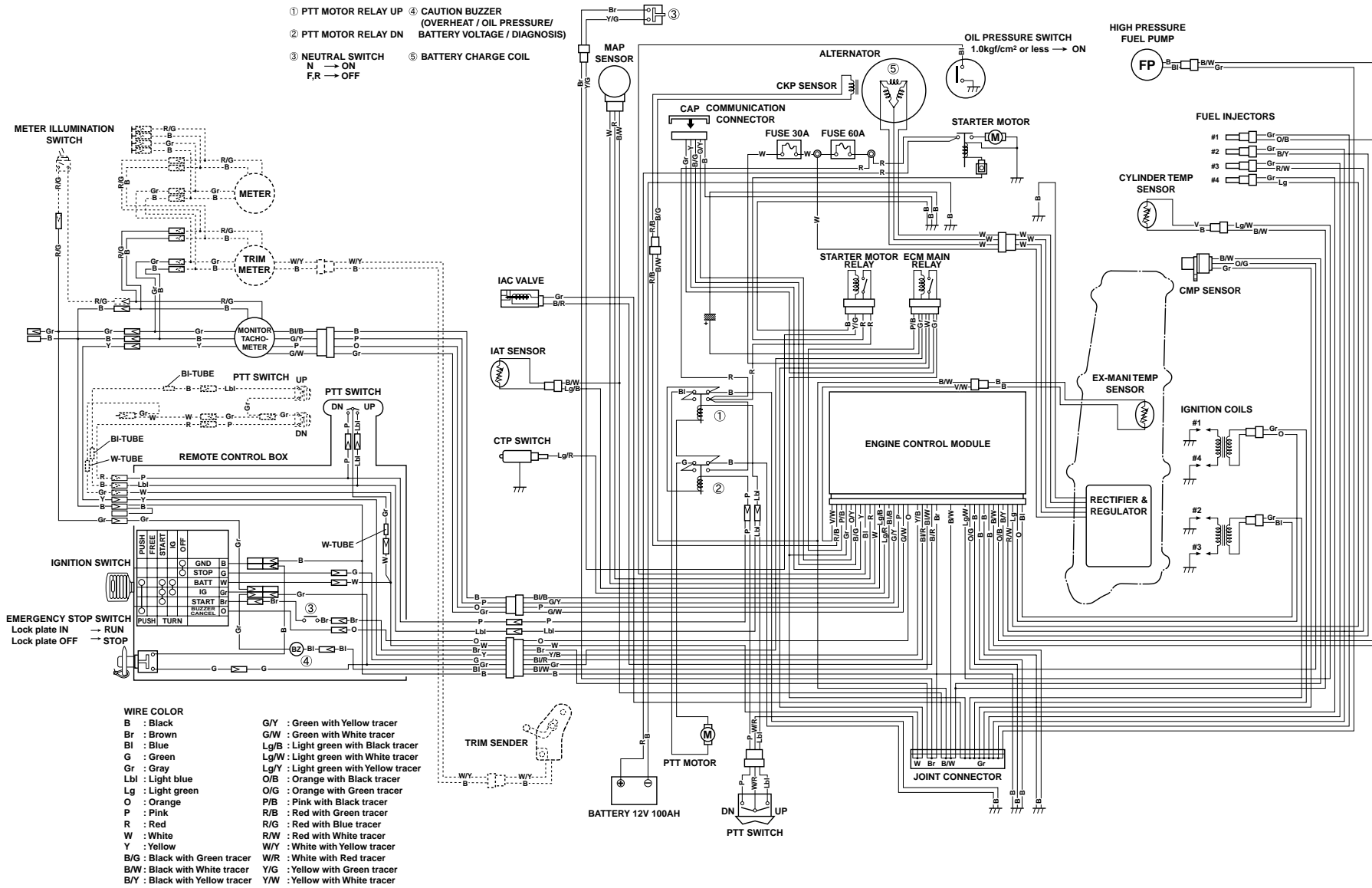

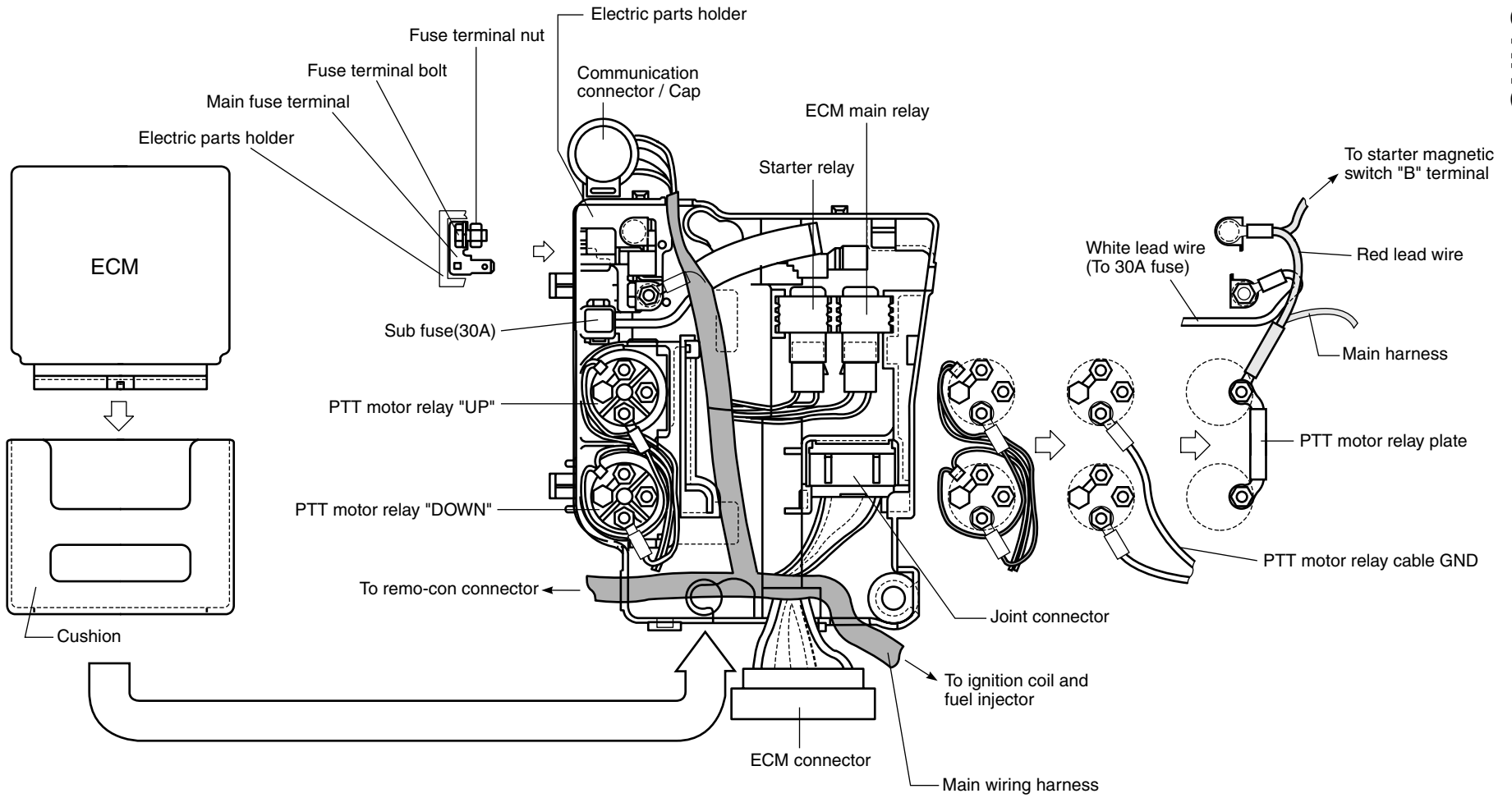

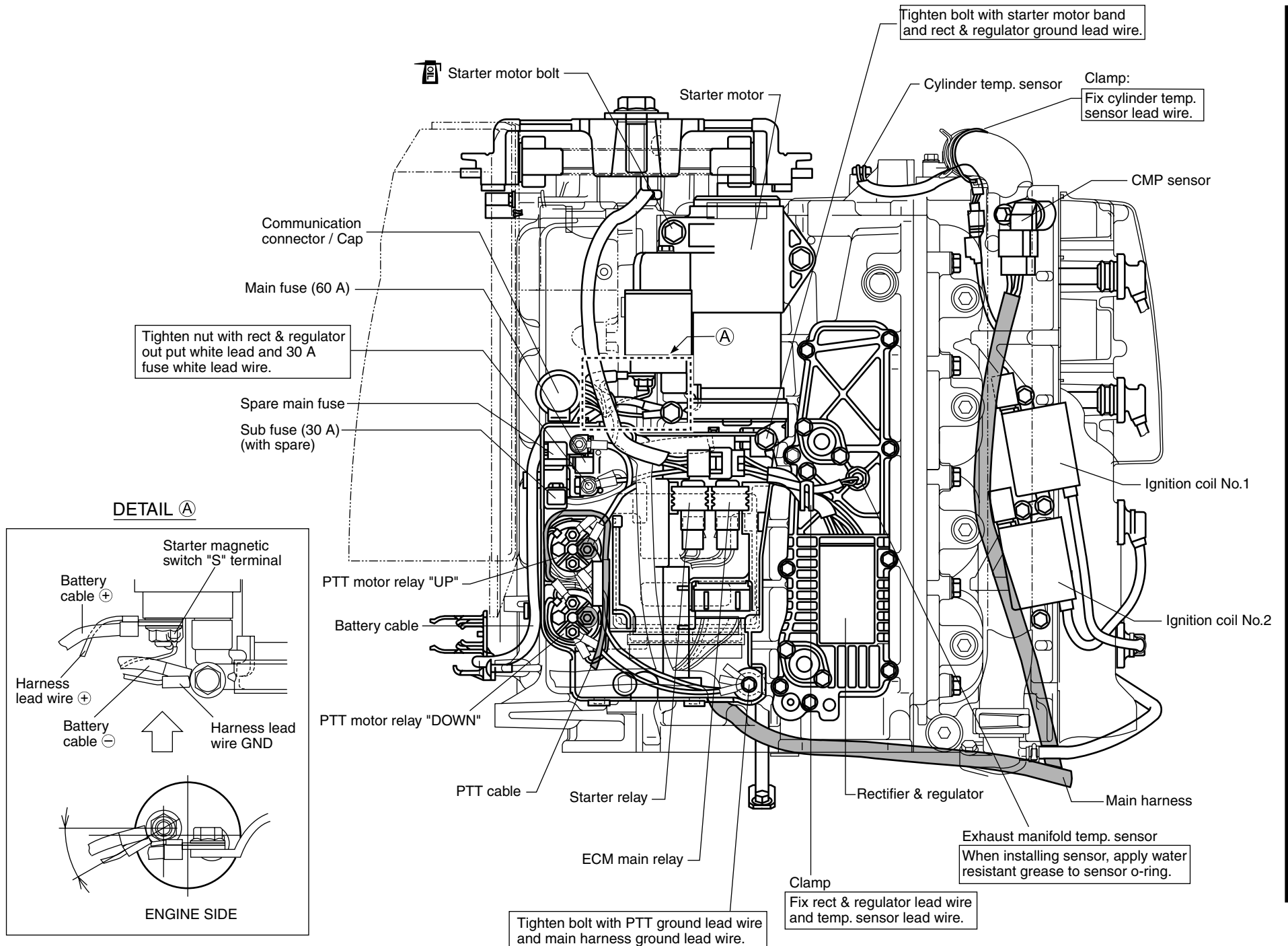

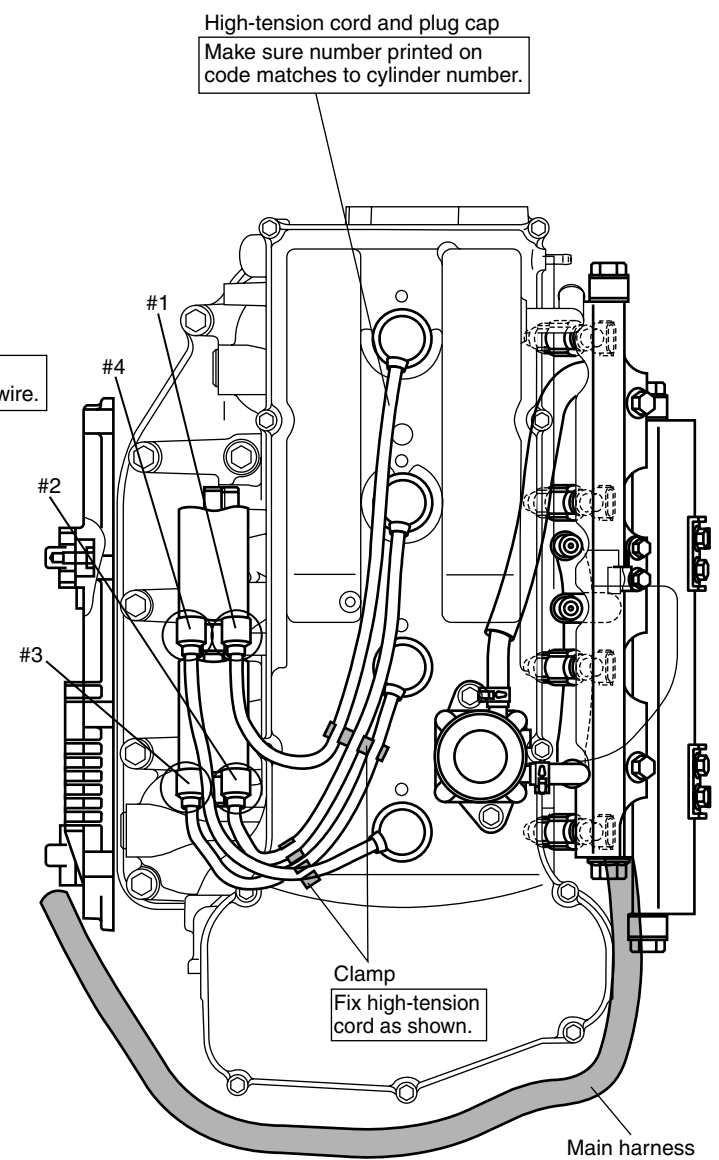
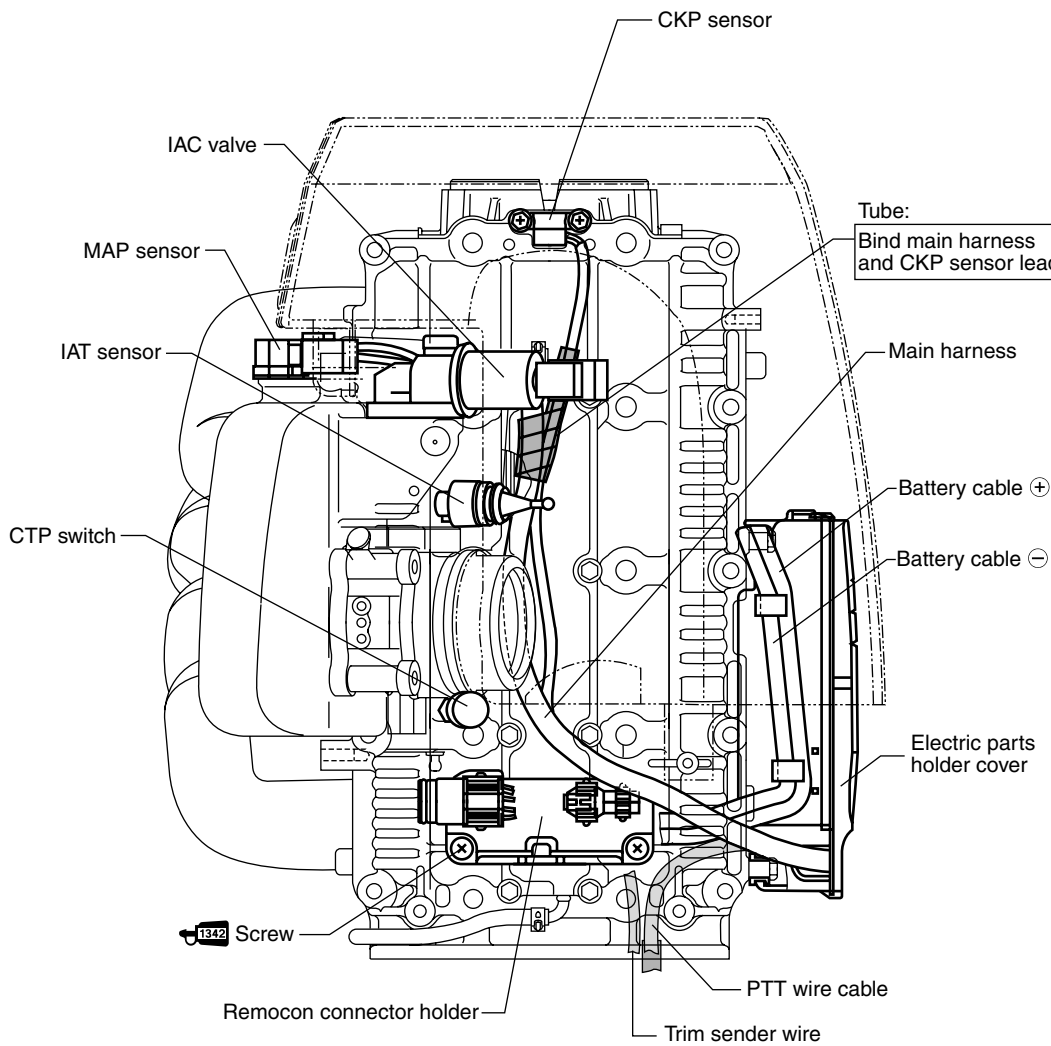

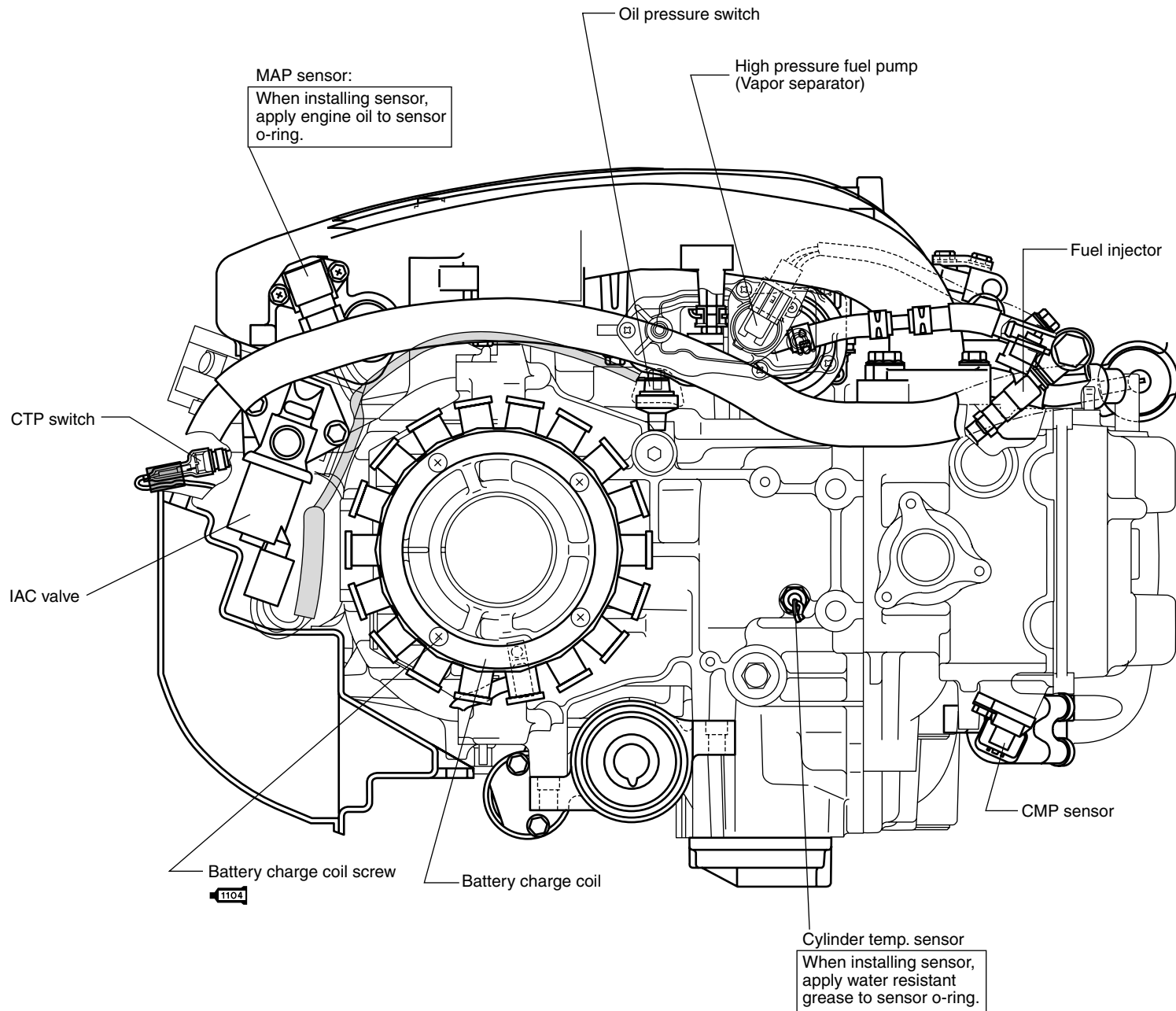

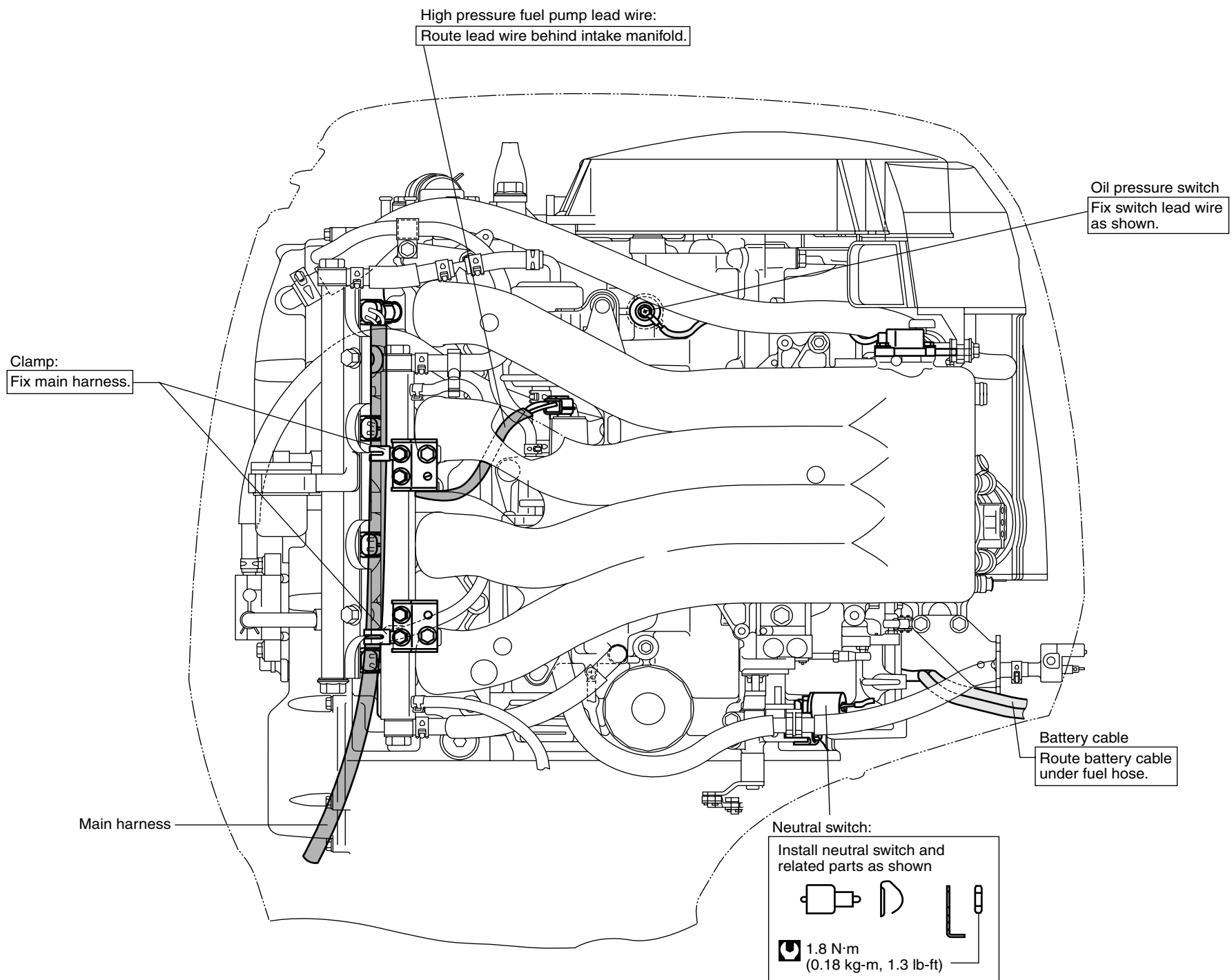

FUEL / WATER HOSE ROUTING

CAUTION

- Do not over-bend (kink) or twist hoses when installing.
- When installing hose clips, position tabs to avoid contact with other parts.
- Check that hoses do not contact rods and levers during either engine operation or standstill.
- Extreme care should be taken not to cut, abrade or cause any other damage on hoses.
- Care should be taken not to cause hoses to be compressed excessively by any clamp when fitted.

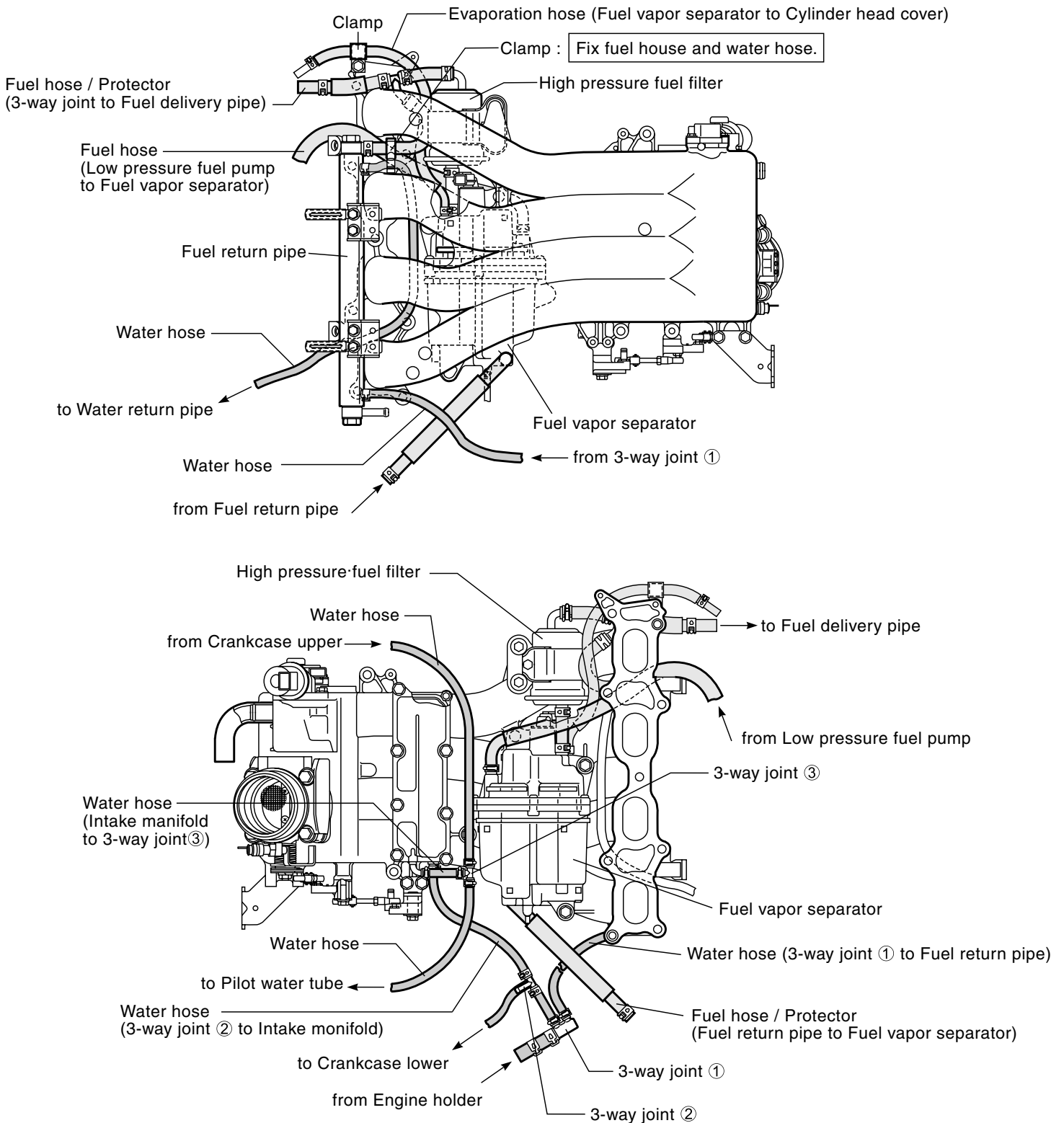

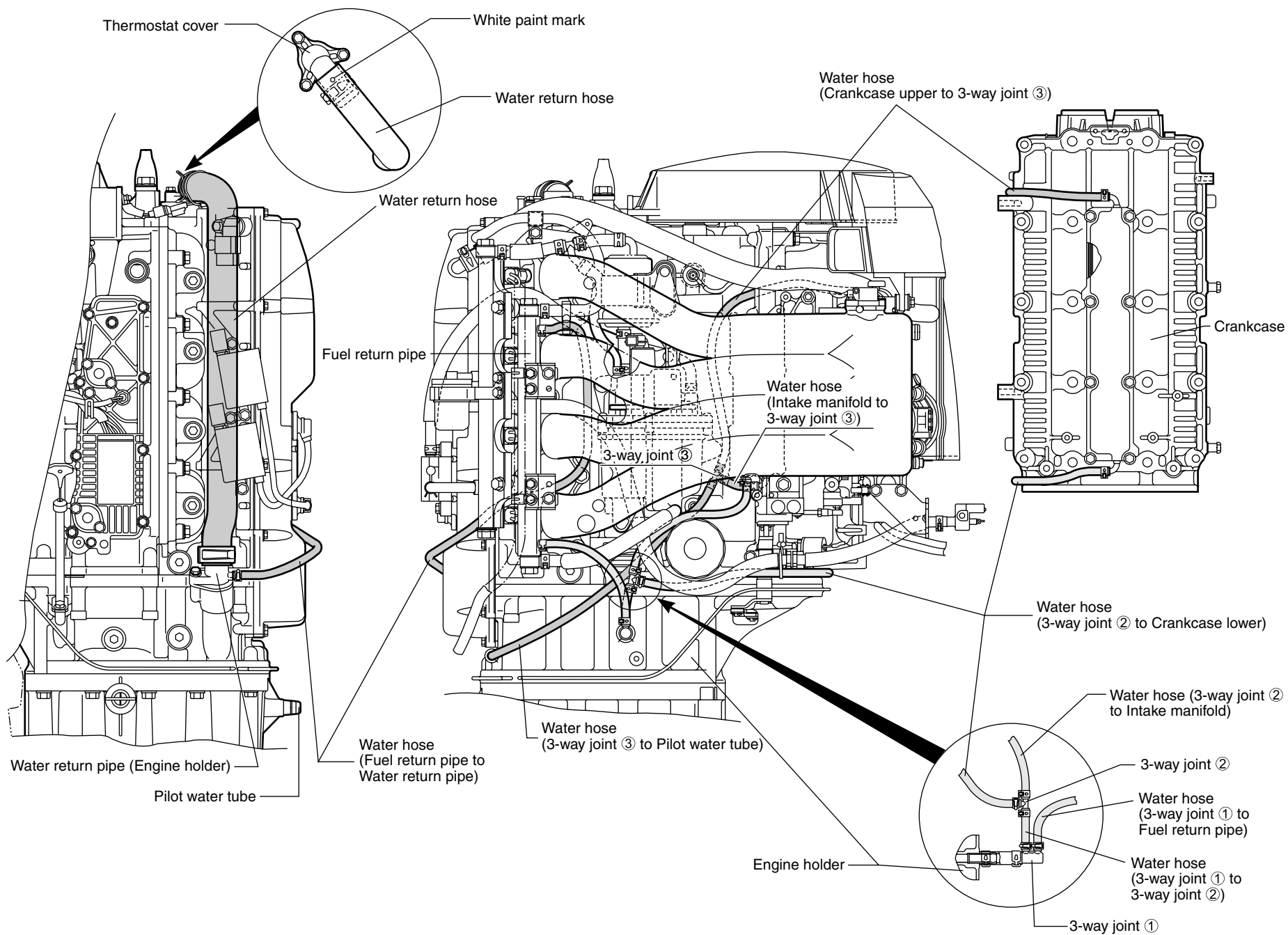

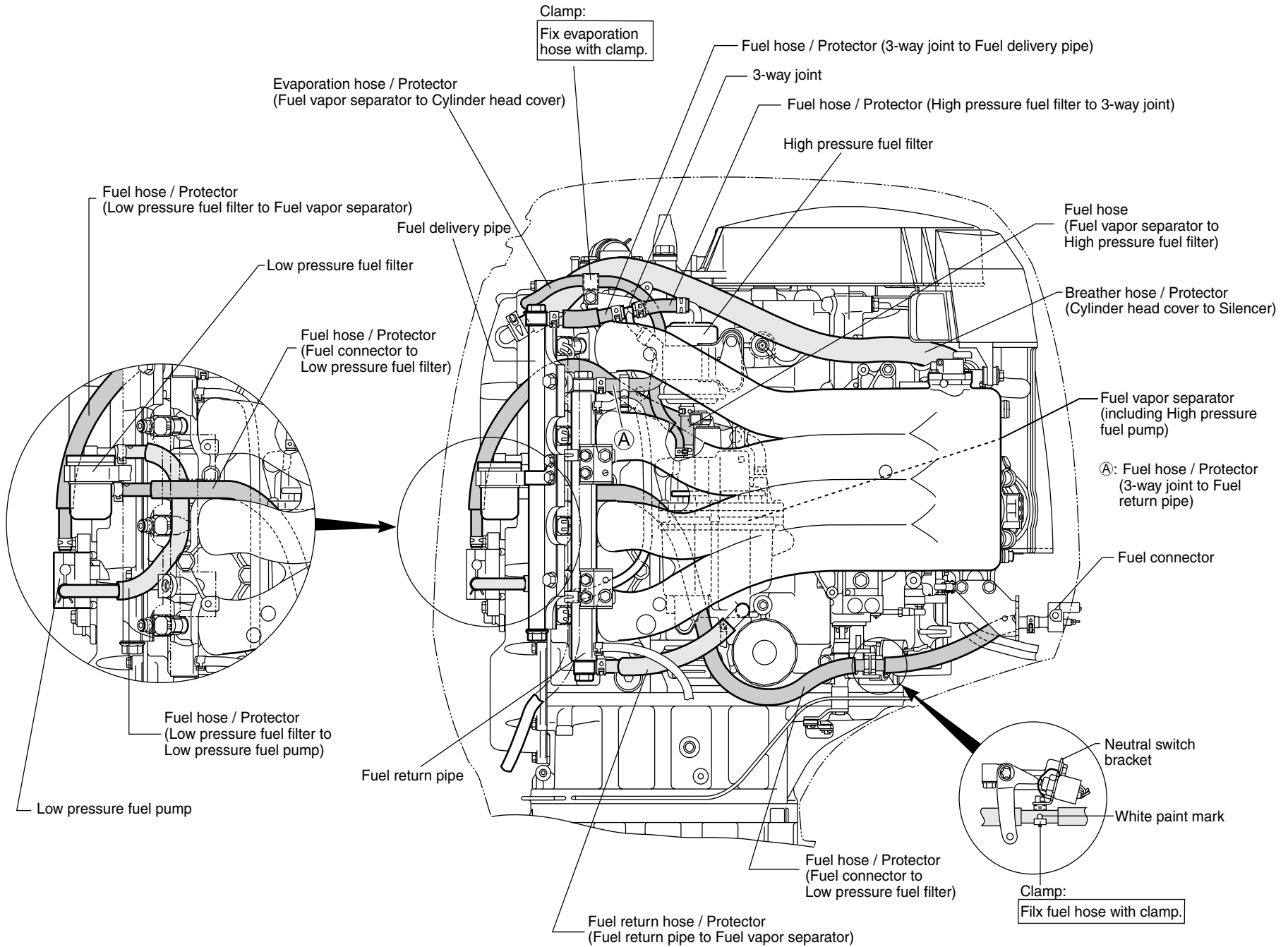

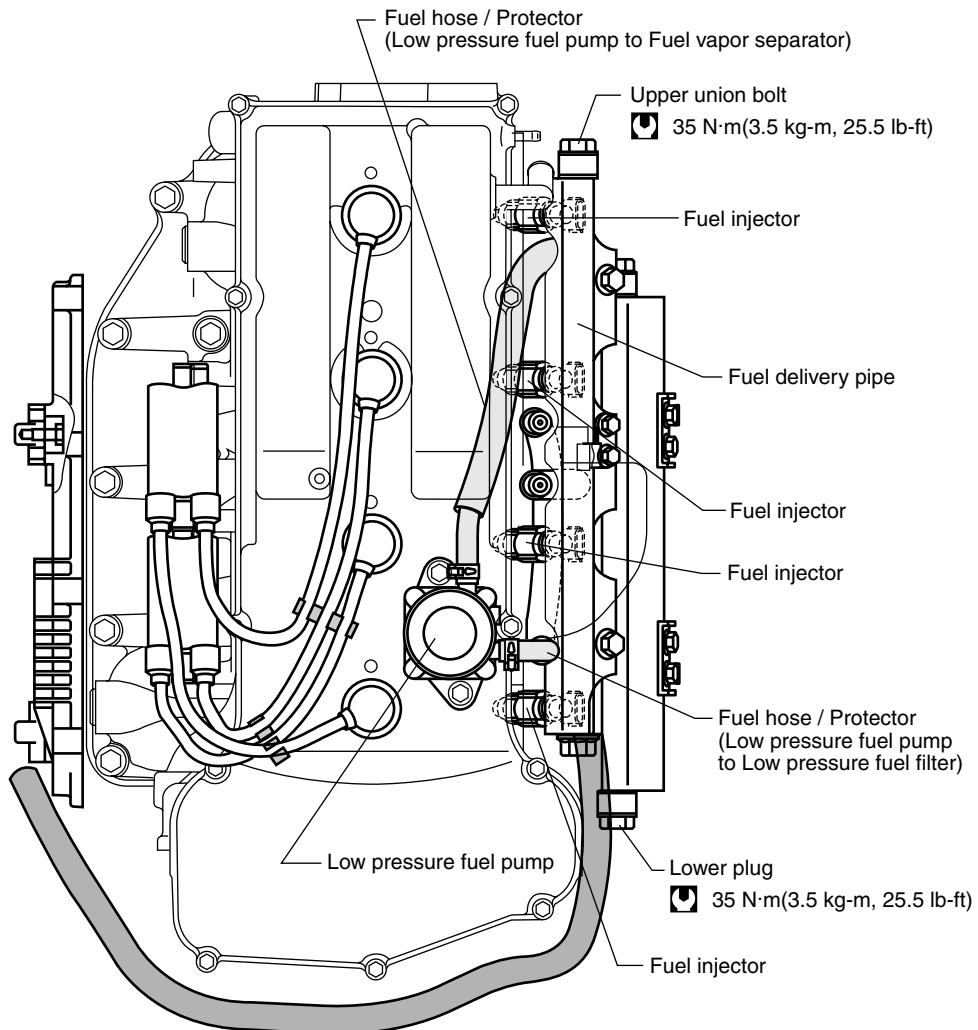
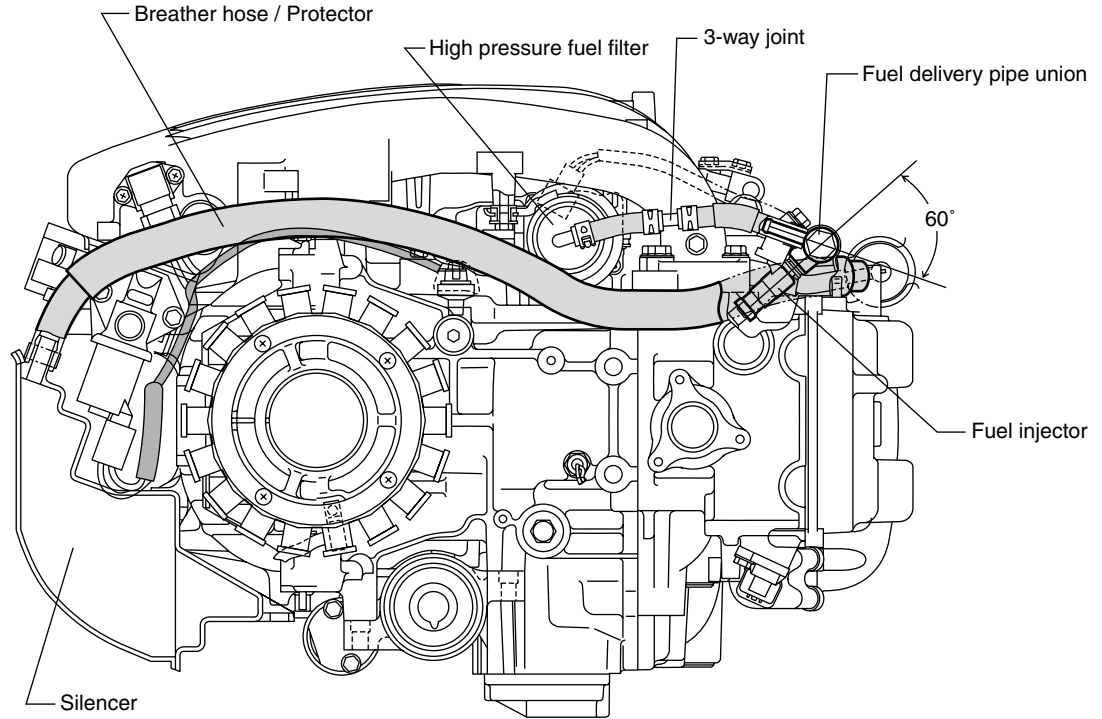

Prepared by

SUZUKI MOTOR CORPORATION

Marine & Power Products Division

2nd Ed. June, 2001

1 st Ed. October, 2000

Manual No. 99500-90J01-01E

Printed in Japan