

LOWER UNIT [Standard rotation (Right-hand) model]

CONTENTS

REMOVAL & DISASSEMBLY	9- 2
INSPECTION	9- 8
PROPELLER	9- 8
GEARCASE	9- 8
GEARS/BEARING	9- 8
FORWARD GEAR BEARING HOUSING	9- 9
PROPELLER SHAFT COMPONENTS	9- 9
PROPELLER SHAFT BEARING HOUSING	9-10
SHIFT ROD GUIDE HOUSING COMPONENTS	9-11
WATER PUMP AND RELATED ITEMS	9-11
DRIVESHAFT OIL SEAL HOUSING	9-12
DRIVESHAFT	9-12
ASSEMBLY & INSTALLATION	9-13
TRIM TAB	9-25
LOWER UNIT GEARS- SHIMMING AND ADJUSTMENT	9-26

REMOVAL & DISASSEMBLY

⚠ WARNING

Always disconnect the battery cable, before removing lower unit.

Shift to "NEUTRAL" position.
Remove bolt and trim tab ①.

Remove seven (7) bolts ② and separate gearcase ③ from driveshaft housing.

NOTE:
Before gearcase is removed completely, disconnect speedometer pick up tube ④ from gearcase.

Remove water tube spacer ⑤.
Remove clutch rod ⑥ from clutch shaft (if necessary).

Place a drain pan under oil drain plug.
Remove oil drain plug ⑦ first then oil level plug ⑧ and allow gear oil to drain.
Inspect oil for water, contaminates or metal.

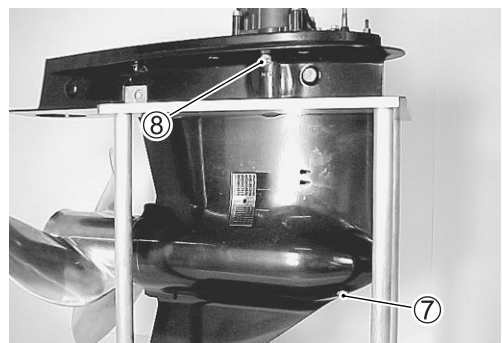
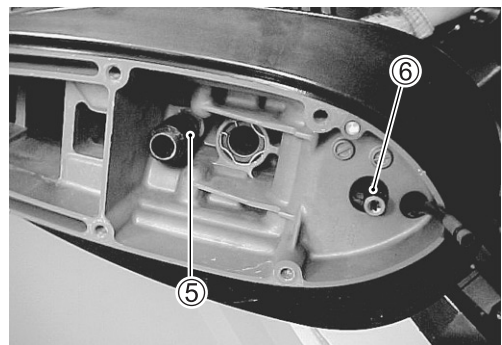
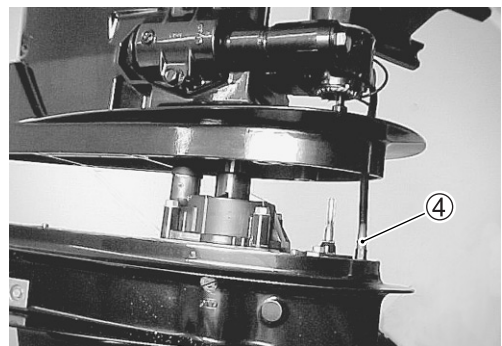
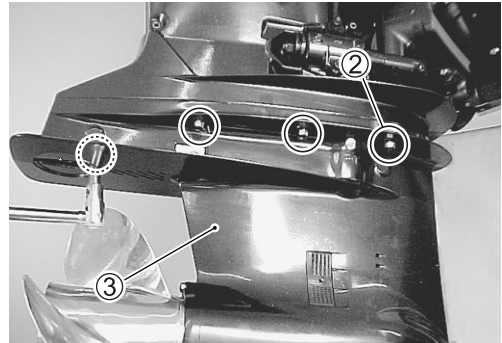
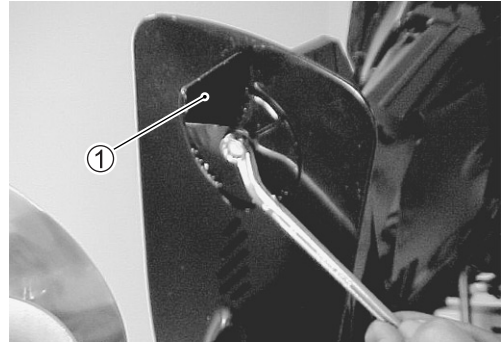

Remove cotter pin ① from propeller nut and remove propeller nut ②.

Remove washer ③, spacer ④, propeller ⑤ and stopper ⑥ from the propeller shaft.

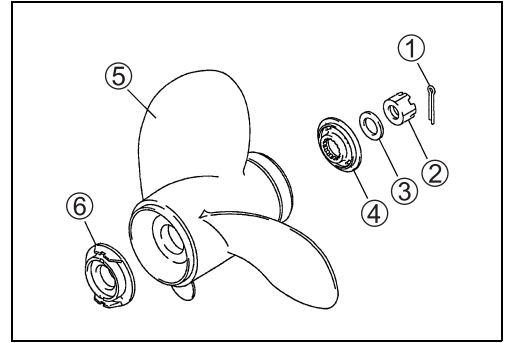

⚠ WARNING

To prevent injury from propeller blades, wear gloves and place a block of wood between the anti-cavitation plate and the propeller blade tips to lock the propeller in place before attempting to remove propeller nut.

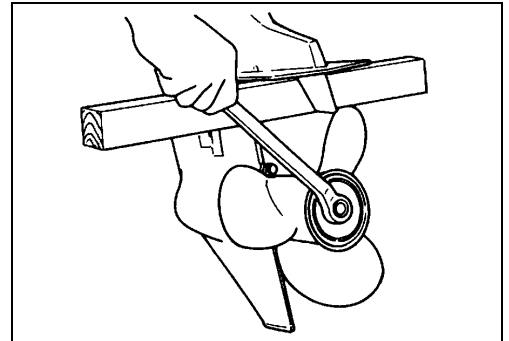

Loosen four (4) bolts ①, then remove water pump case ②.

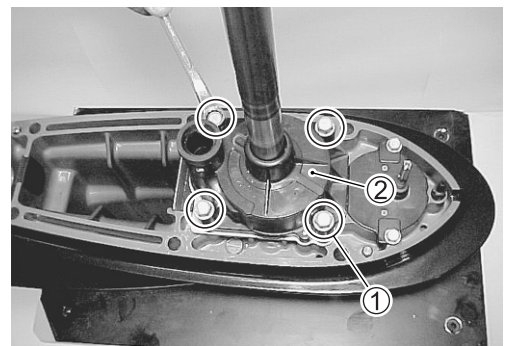

Remove impeller ③, impeller key ⑥, pump under plate ④ and dowel pins ⑤.

Keep impeller key ⑥ for reuse and discard the plate gasket.

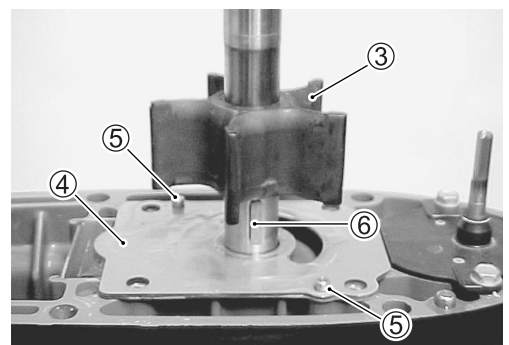

Remove two (2) bolts ① and shift rod guide housing assembly ②.

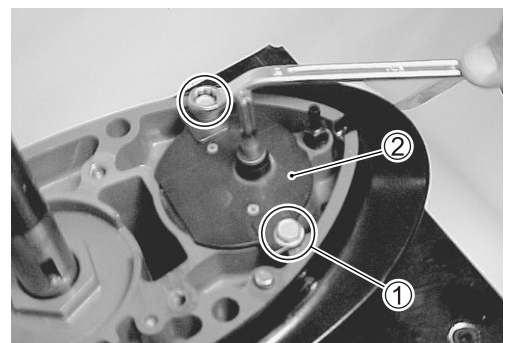

Remove two (2) bolts ① securing the propeller shaft bearing housing to the gearcase.

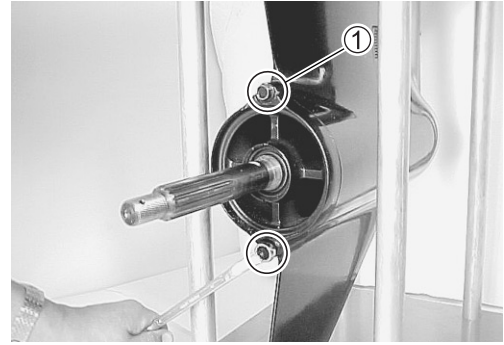

Using special tools, pull out the propeller shaft bearing housing. Remove the propeller shaft and bearing housing assembly ②.

- TOOL 09930-30102: A Sliding hammer**
- 09930-30161: B Propeller shaft remover**

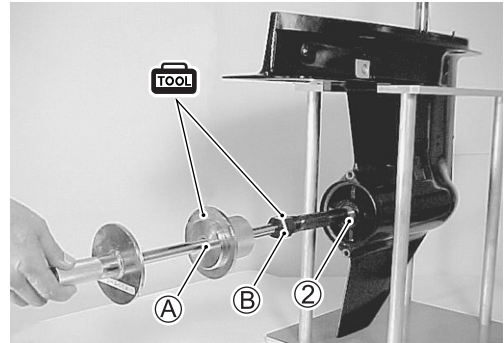

Hold the pinion nut securely, then fit special tool to the driveshaft and loosen the pinion nut. Remove pinion nut ③ and washer ④.

- TOOL 09921-29410: Driveshaft holder**

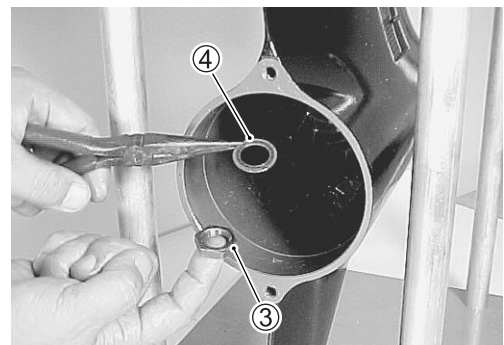
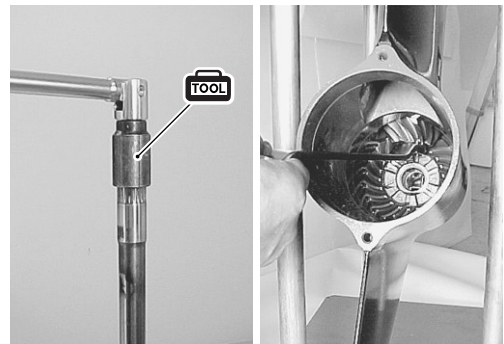

Use special tool to unscrew driveshaft oil seal housing ①, then remove oil seal housing from drive shaft.

- TOOL 09926-29310: Driveshaft housing remover**

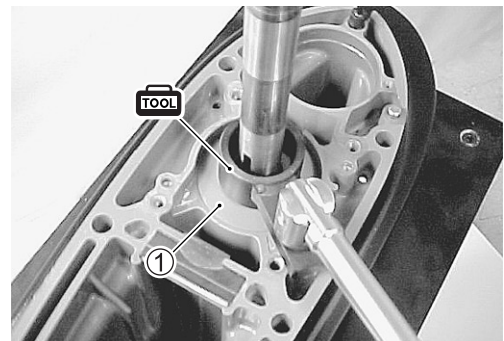

Remove driveshaft bearing spacer ②.

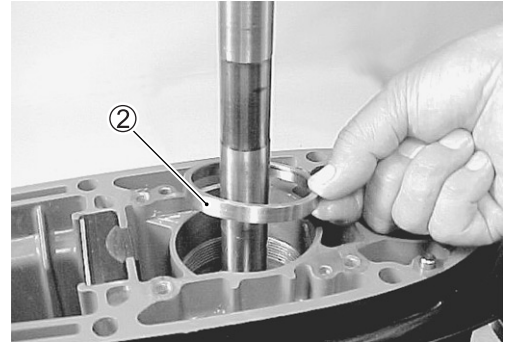

Slowly lift out driveshaft assembly ③.

Remove the pinion shim ④.

NOTE:

The driveshaft pinion gear bearing contains 28 loose roller bearings. Account for all roller bearings on disassembly.

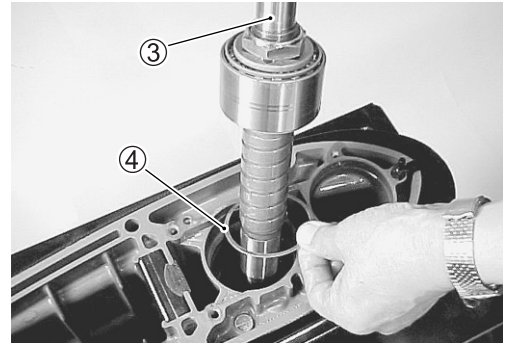

Remove the driveshaft collar ⑤.

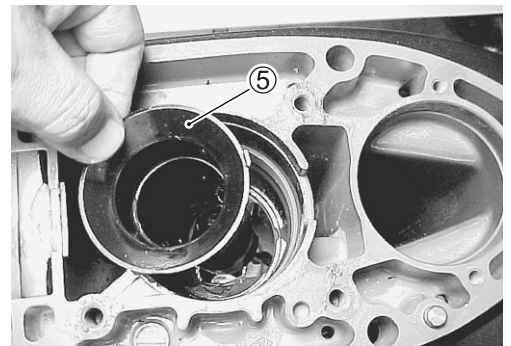

Remove the pinion gear ①.

Remove the forward gear ② and thrust bearing ③.

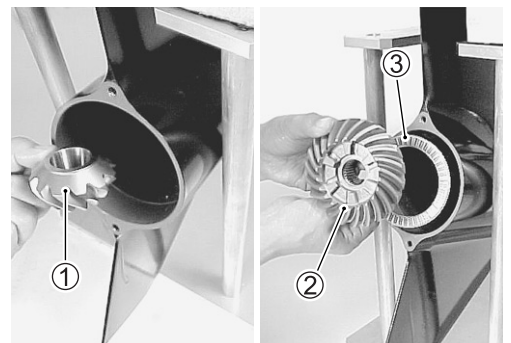

Remove the bearing thrust washer ④ and back-up shim ⑤.

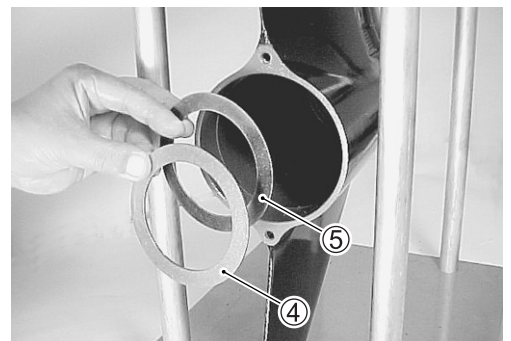

Remove the forward gear bearing housing ⑥.
Account for dowel pin ⑦.

NOTE:

*The forward gear radial bearing contains 35 loose roller bearing.
Account for all roller bearings on disassembly.*

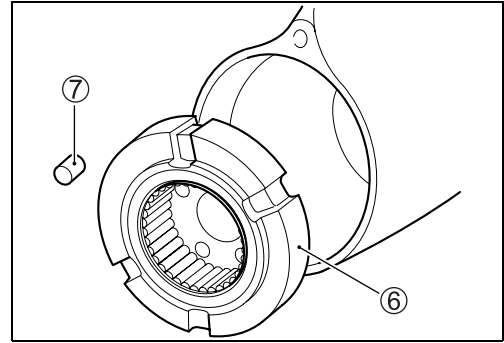

Disassembly of propeller shaft components

Slide propeller shaft away from reverse gear ③ and bearing housing assembly ①.
Account for the reverse gear back-up shim ② and reverse gear thrust washer ④.

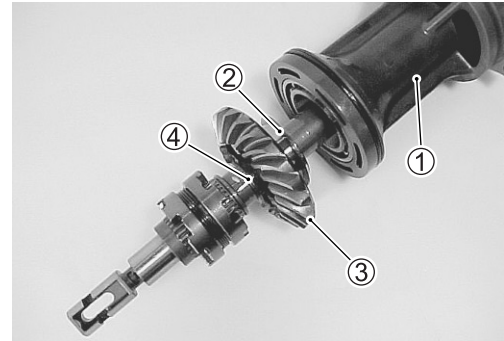

To disassemble propeller shaft components, refer to following:

- (a) Remove horizontal slider ⑤ and forward gear thrust washer ⑥.
- (b) Remove spring ⑦ from clutch dog shifter.

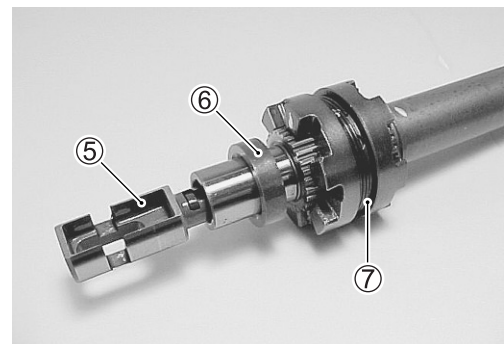

- (c) Use special tool to push the dog pin ⑧ out of the clutch dog shifter.

TOOL 09922-89810: Shift pin remover

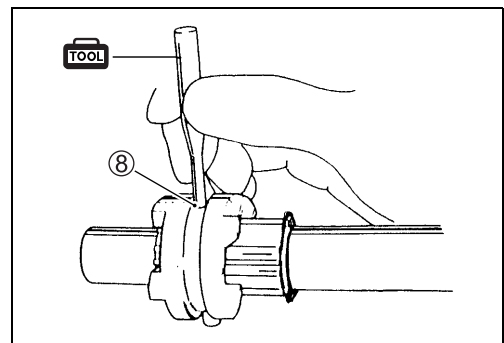

- (d) Remove clutch dog shifter ⑨ and connector pin ⑩ from propeller shaft.

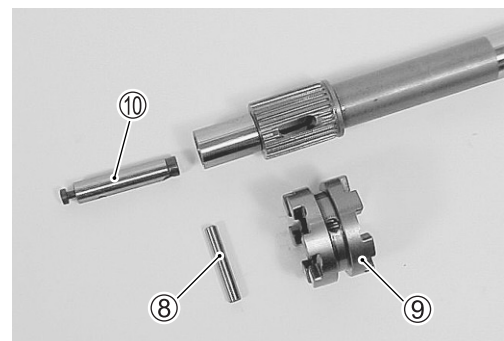

- (e) Remove large detent ball ⑪, detent spring ⑫, large detent ball ⑬ and two (2) small detent balls ⑭ from connector pin.

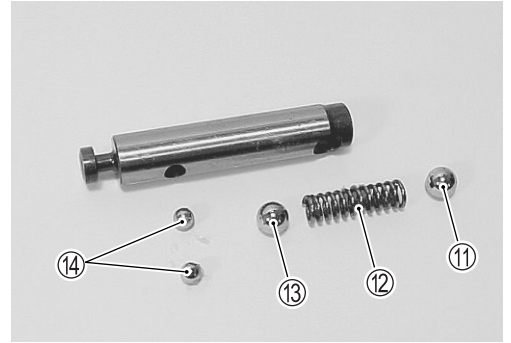

Disassembly of shift rod components

- (a) Remove dust seal ①.
 (b) Slide shift rod ② out of shift rod guide housing ③.

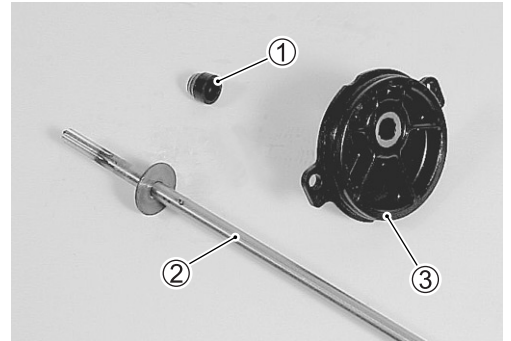

- (c) Remove pin ④ and shifter yoke ⑤.

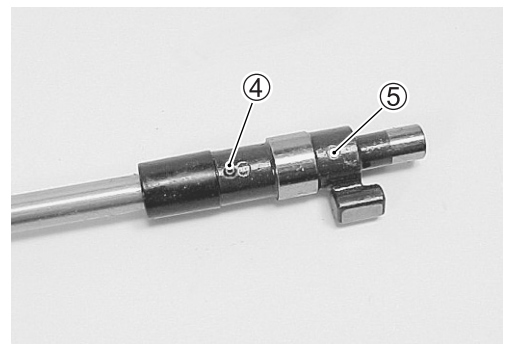

Disassembly of water pump case

Remove inner sleeve ① and rubber seal ring ②.

NOTE:

To facilitate the removal of inner sleeve from the pump case, warm up the entire case using a heater like hair dryer.

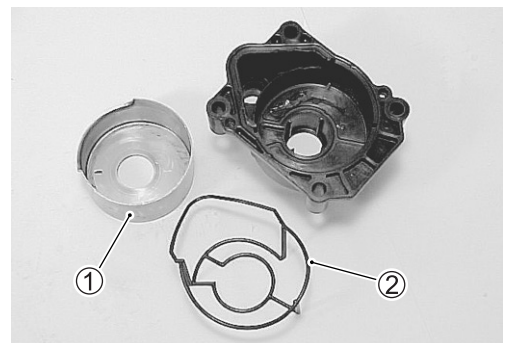

INSPECTION

NOTE:

If any component is worn excessively, cracked, defective or damaged in any way, it must be replaced.

NOTE:

Thoroughly wash all metal components with cleaning solvent and dry with compressed air.

⚠ WARNING

Wear safety glasses when using compressed air.

PROPELLER

- Inspect propeller for bent, chipped or broken blades. Replace or repair propeller if in damaged condition.
- Inspect propeller bush splines. Replace or repair propeller if splines are worn or damaged.
- Inspect propeller bush for deterioration or slipping. Replace if necessary.

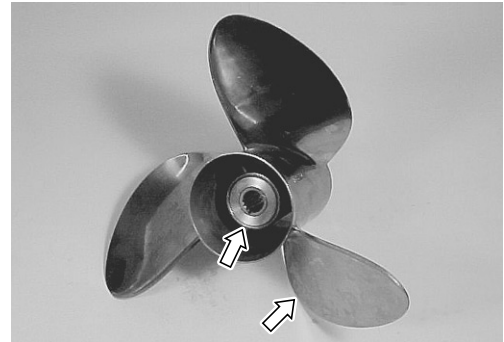

GEARCASE

- Inspect the gearcase. Replace if cracked, damaged or other abnormal condition.
- Visually check the pinion bearing. Replace gearcase if pitted, noisy, rough or other abnormal condition.



GEARS/BEARING

- Inspect forward, reverse and pinion gear teeth and engaging dogs. Replace gears if damaged, worn or other abnormal condition.
- Inspect propeller shaft forward bearing, forward gear thrust bearing. Replace bearing if pitted, noisy, rough or other abnormal condition.

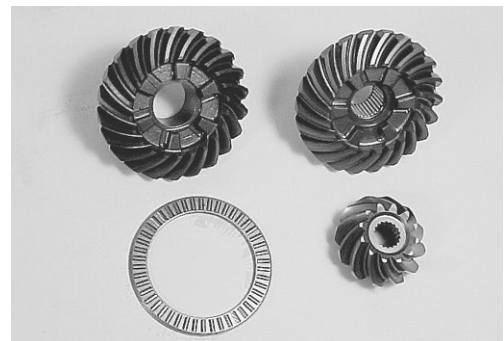

FORWARD GEAR BEARING HOUSING

- Inspect forward gear bearing housing.
Replace if cracked, damaged or other abnormal condition.
- Visually check bearing. Replace if pitted, rough or other abnormal condition.

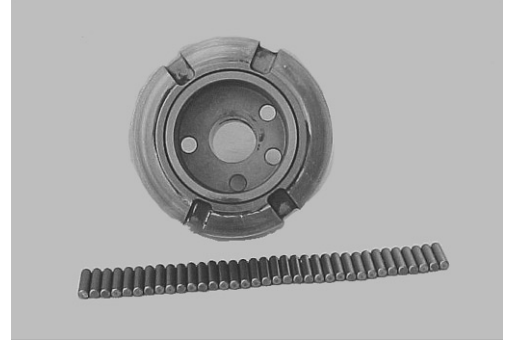

PROPELLER SHAFT COMPONENTS

- Inspect horizontal slider and connector pin.
Replace if worn, damaged or other abnormal condition.
- Inspect clutch dog shifter. Replace if chipped, worn, damaged or other abnormal condition.
- Inspect dog pin. Replace if bent, worn or other abnormal condition.
- Inspect detent balls. Replace if wear, damage or other abnormal condition.
- Inspect propeller shaft/splines. Replace if worn, twisted, damaged or other abnormal condition.

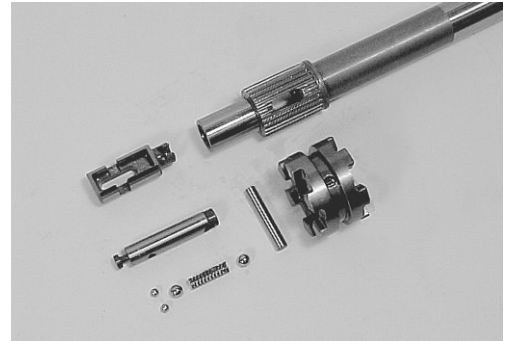

- Check detent spring by measuring its free length. If free length is not within specifications, replace detent spring.

Detent spring free length (L)

Standard: 27.8 mm (1.09 in)

Service limit: 25 mm (0.98 in)

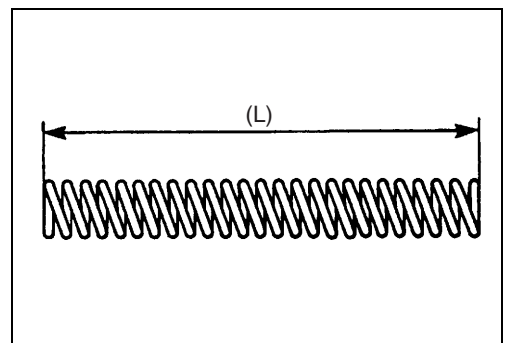

PROPELLER SHAFT BEARING HOUSING

- Inspect housing. Replace if cracked, damaged or other abnormal condition.
- Inspect reverse gear bearing. Replace bearing if pitted, noisy, rough or other abnormal condition.
- Check condition of oil seal and O-ring.
Replace oil seal and O-ring if nicked, cut, worn or other abnormal condition.



Replacing propeller shaft oil seal

1. Extract seals ① with oil seal remover.

TOOL 09913-50121: Oil seal remover

CAUTION

**Do not reuse oil seal once removed.
Always use new oil seal.**

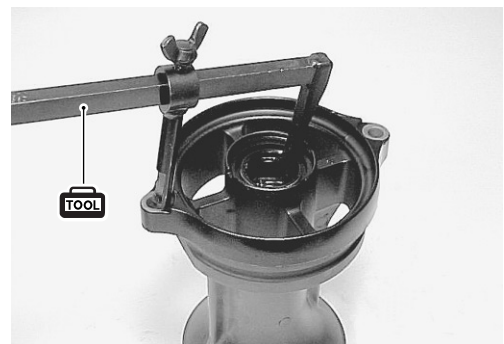

2. Apply Water Resistant Grease to the inner circumference of the housing.
3. Using an oil seal installer, drive the two oil seals (one at a time) into the propeller shaft bearing housing.
The lipped portion of the seal must face towards the propeller.
Apply Water Resistant Grease to the seal lips.

WRG's 99000-25160: SUZUKI WATER RESISTANT GREASE

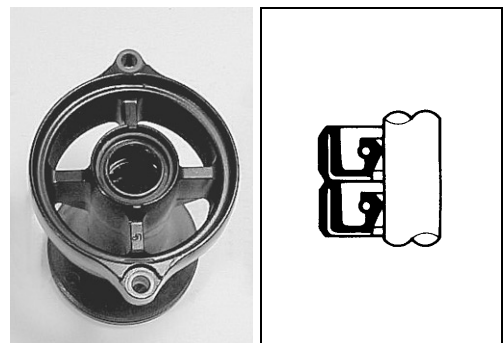

SHIFT ROD GUIDE HOUSING COMPONENTS

- Inspect shift rod guide housing. Replace if cracked, damaged or other abnormal condition.
- Inspect shifter yoke. Replace if wear, damaged or other abnormal condition.
- Inspect shift rod/splines. Replace if worn, twisted, damaged or other abnormal condition.
- Inspect O-ring. Replace if nicked, cut, torn, swollen or other abnormal condition.
- Inspect oil seal and dust seal. Replace if nicked, cut, worn or other abnormal condition.

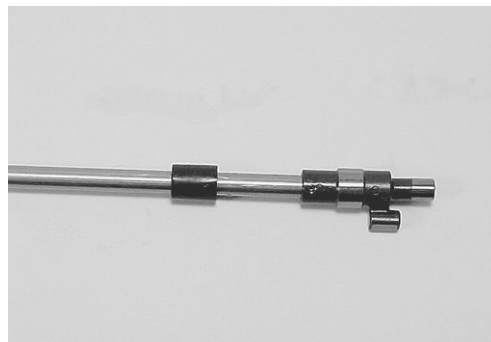
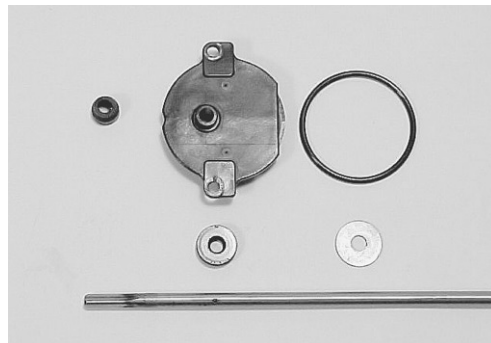

WATER PUMP AND RELATED ITEMS

- Inspect impeller. Replace if vanes are cut, torn, worn or other abnormal condition.
- Inspect pump case. Replace if cracked, distorted or other abnormal condition.
- Inspect pump inner sleeve. Replace if worn, cracked, distorted, corroded or other abnormal condition.
- Inspect seal ring. Replace if nicked, cut, torn, swollen or other abnormal condition.
- Inspect under panel. Replace if cracked, distorted, corroded or other abnormal condition.

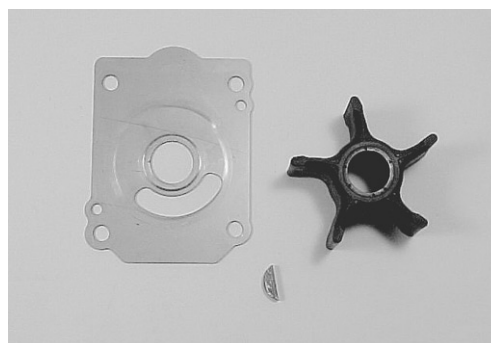

DRIVESHAFT OIL SEAL HOUSING

- Inspect housing. Replace if cracked, damaged or other abnormal condition.
- Check condition of oil seals. Replace if nicked, cut, worn or other abnormal condition.
- Inspect O-ring. Replace if worn, nicked, cut or other abnormal condition.

Replacing driveshaft oil seal

1. Using special tool, remove two (2) oil seals out of the driveshaft oil seal housing.

 **09913-50121: Oil seal remover**

2. Apply Water Resistant Grease to inner circumference of driveshaft oil seal housing.

 **99000-25160: SUZUKI WATER RESISTANT GREASE**

3. Grease the inner lips of oil seal. With the lips facing away from driveshaft bearing, place seal in position and drive it into the oil seal housing.

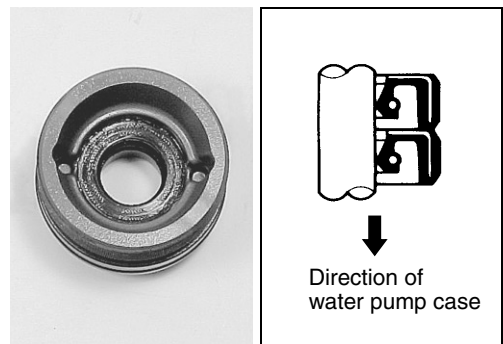
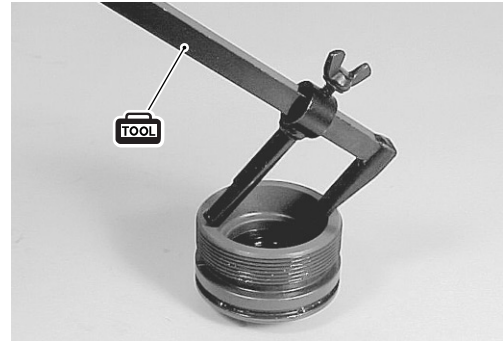
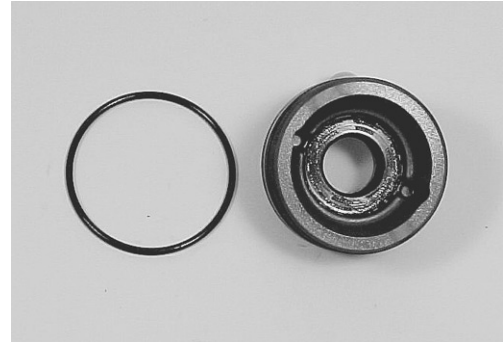

DRIVESHAFT

- Inspect driveshaft/splines. Replace if worn, twisted, damaged or other abnormal condition.
- Inspect driveshaft bearing, replace if pitted, noisy, rough or other abnormal condition.

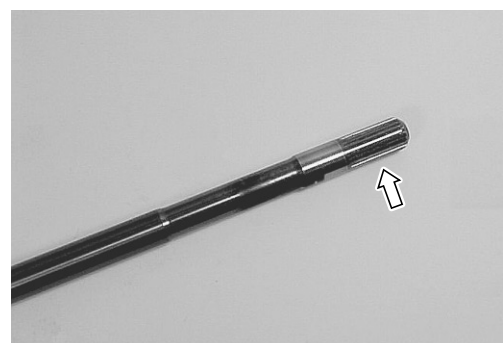
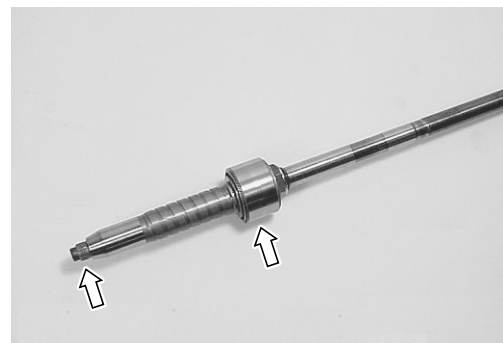

ASSEMBLY & INSTALLATION

Assembly & installation are reverse order of disassembly with special attention to the following steps.

1. Clutch lever
2. Bush
3. Pin
4. Pin
5. Ball
6. Spring
7. Clutch notch plate
8. Clutch lever holder
9. Clutch shaft arm
10. E-ring
11. Bush
12. Clutch lever link
13. Washer
14. Pin
15. Clutch shaft
16. Clutch rod cover
17. Clutch rod
18. Oil seal
19. Bearing
20. Circlip
21. Plug
22. Shift rod
23. Bolt
24. Clutch rod cover
25. Shift rod housing
26. O-ring
27. Oil seal
28. Washer
29. Pin
30. Magnet
31. Shifter yoke
32. Horizontal slider
33. Nipple
34. Pin
35. Exhaust rubber seal
36. Exhaust seal plate
37. Grommet
38. Pinion bearing
39. Trim tab
40. Bolt
41. Washer
42. Bolt
43. Bolt
44. Water filter PORT
45. Water filter STBD
46. Screw
47. Anode
48. Bolt
49. Gear case
50. Bush
51. Water pump case
52. Bolt
53. Pin
54. Key
55. Case sealing
56. Sleeve
57. Water pump impeller
58. Under panel
59. Gasket

17 N·m
(1.7 kg-m, 12.3 lb-ft)

54 N·m
(5.5 kg-m, 40.0 lb-ft)

83 N·m
(8.3 kg-m, 60.0 lb-ft)

- 60. Driveshaft
- 61. Oil seal housing
- 62. O-ring
- 63. Oil seal
- 64. Nut
- 65. Spacer
- 66. Driveshaft bearing
- 67. Shim
- 68. Driveshaft collar
- 69. Pinion gear
- 70. Washer
- 71. Pinion nut
- 72. Plug
- 73. Gasket
- 74. Pin
- 75. F-gear bearing housing w/bearing
- 76. Shim
- 77. Thrust washer
- 78. FWD Bearing
- 79. Forward gear
- 80. Detent ball
- 81. Connector pin
- 82. Detent spring
- 83. Detent ball
- 84. Thrust washer
- 85. Clutch dog shifter
- 86. Dog pin
- 87. Dog spring
- 88. Thrust washer
- 89. Reverse gear

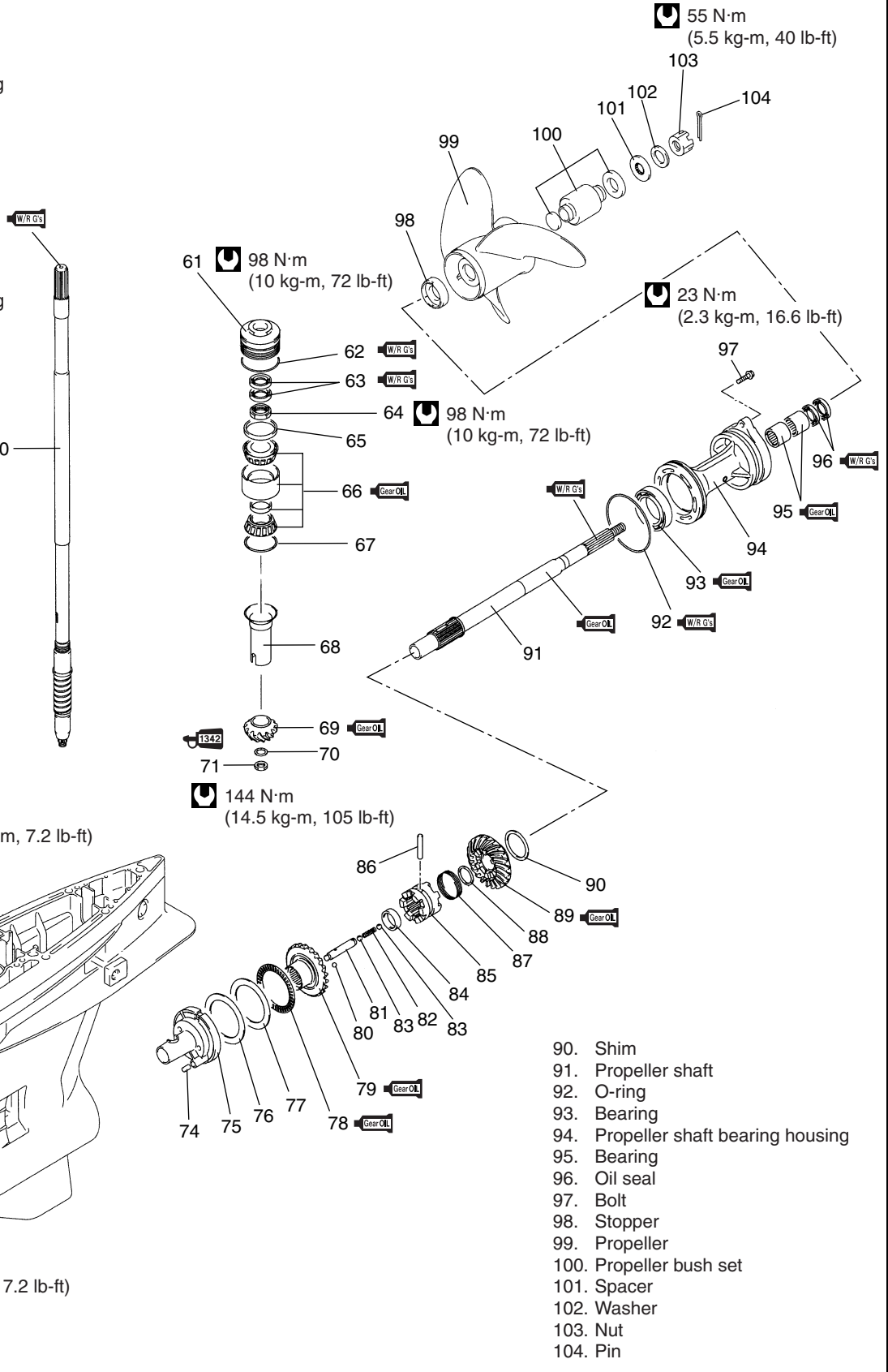

- 90. Shim
- 91. Propeller shaft
- 92. O-ring
- 93. Bearing
- 94. Propeller shaft bearing housing
- 95. Bearing
- 96. Oil seal
- 97. Bolt
- 98. Stopper
- 99. Propeller
- 100. Propeller bush set
- 101. Spacer
- 102. Washer
- 103. Nut
- 104. Pin

CAUTION

- Make sure that all parts used in assembly are clean and lubricated.
- It is recommended that all seals, gaskets and O-rings be replaced with new on assembly.
- After assembly, check parts for tightness and smoothness of operation.
- Before final assembly, be absolutely certain that all gear contact, shim adjustments and tolerances are correct.

Failure to correctly adjust these areas will result in lower unit damage.

(See “GEARS SHIMMING AND ADJUSTMENT” section on page 9-26.)

FORWARD GEAR BEARING HOUSING

- Install dowel pin ① and forward gear bearing housing ②.

NOTE:

Before installing forward gear, check for correct amount and position of forward gear radial bearing rollers.

Use oil soluble grease to retain bearing rollers.

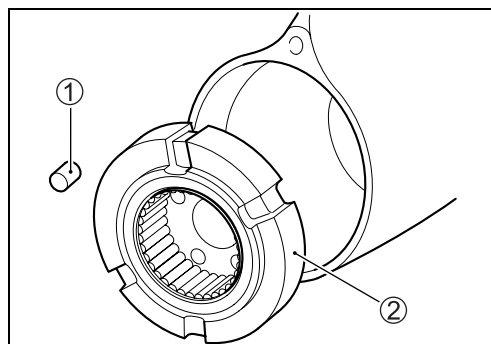
**FORWARD GEAR**

Place the forward gear back-up shim ①, thrust washer ②, forward gear thrust bearing ③ in position, then install forward gear ④.

 99000-22540: SUZUKI OUTBOARD MOTOR GEAR OIL

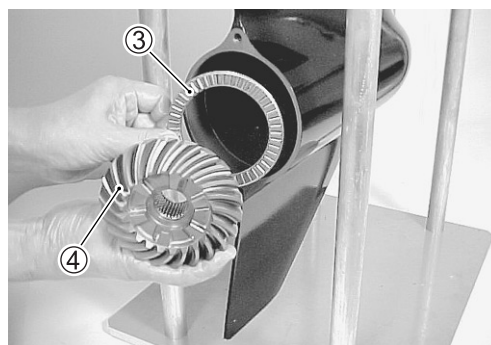
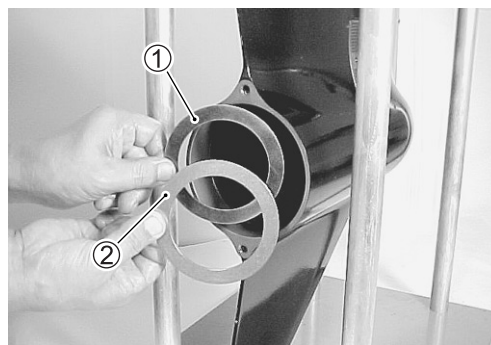

DRIVESHAFT COLLAR

Install driveshaft collar ①.

NOTE:

The tongue Ⓐ of collar must be located into groove on the gearcase.

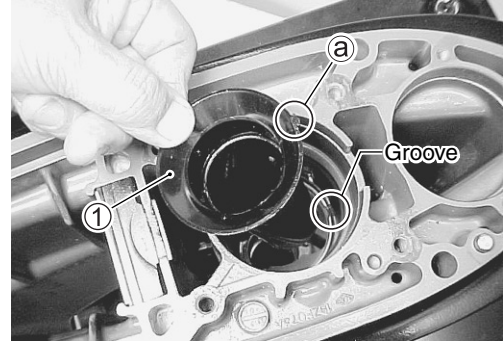

PINION GEAR

Place pinion gear in gearcase.

NOTE:

Before installing pinion gear, check for correct amount and position of pinion bearing rollers.

Use oil soluble grease to retain bearing rollers.



DRIVESHAFT

Install pinion shim ①, then lower the driveshaft assembly ② down into the gearcase until the bottom of shaft protrudes through center of pinion.

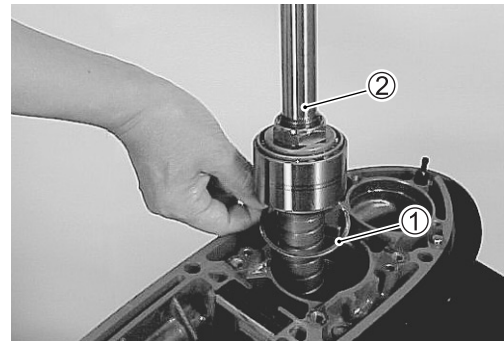

DRIVESHAFT OIL SEAL HOUSING

- Apply Water Resistant Grease to the driveshaft oil seal.
- Apply Water Resistant Grease to O-ring ①, then install O-ring into groove on the driveshaft oil seal housing.

W/R G's 99000-25160: SUZUKI WATER RESISTANT GREASE

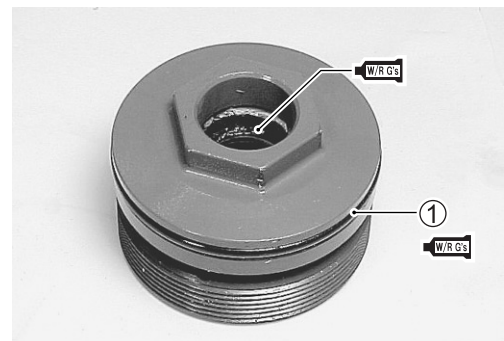

- Install driveshaft bearing spacer ②.



- Install driveshaft oil seal housing on gearcase, then tighten oil seal housing to specified torque.

 **Driveshaft oil seal housing: 98 N·m (10 kg-m, 72 lb-ft)**

 **09926-29310: Driveshaft housing remover**

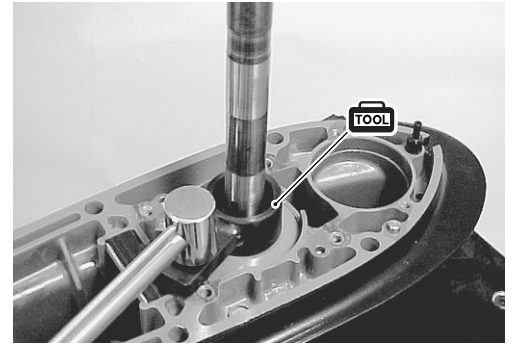

PINION NUT

- Apply THREAD LOCK 1342 to the threads of pinion nut ② before threading it onto driveshaft.

 **99000-32050: THREAD LOCK 1342**

NOTE:

It is recommended the original pinion nut be used for the purposes of shimming during repair. A new pinion nut should be used on final assembly.

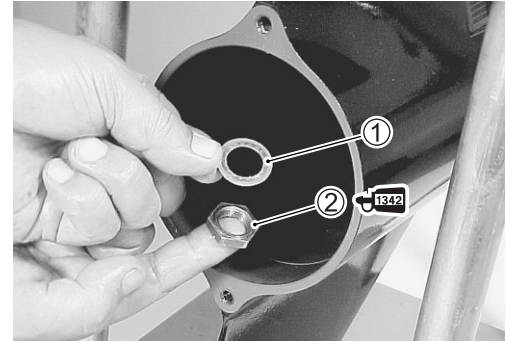

- Install washer ①, pinion nut ②, then tighten nut to specified torque.

 **Pinion nut: 144 N·m (14.5 kg-m, 105 lb-ft)**

 **09921-29410: Driveshaft holder**

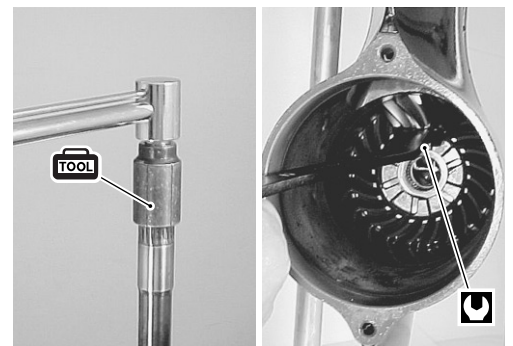

CHECKING GEAR BACKLASH

Before installing reverse gear, gear backlash should be checked. (See the “GEARS-SHIMMING AND ADJUSTMENT/CHECKING BACKLASH” section on page 9-27.)

 **09952-09310: Backlash indicator tool**



PROPELLER SHAFT

- Slide the clutch dog shifter ② onto the propeller shaft ①.

NOTE:

The side of the clutch dog shifter marked with the letter “F” must face towards forward gear.

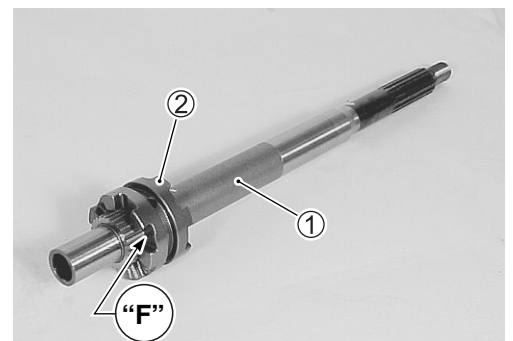

- Insert two (2) small detent balls ④, large detent ball ⑤, detent spring ⑥ and large detent ball ⑦ into connector pin ③.
Then depress detent ball ⑦ and temporarily insert stopper pin ⑨ into dog pin hole of connector pin, as shown in right figure.

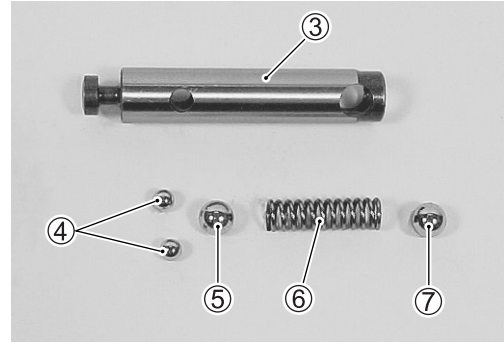

NOTE:

Temporarily insert a gearcase dowel pin ⑨ into the connector pin to prevent the detent ball from falling out.

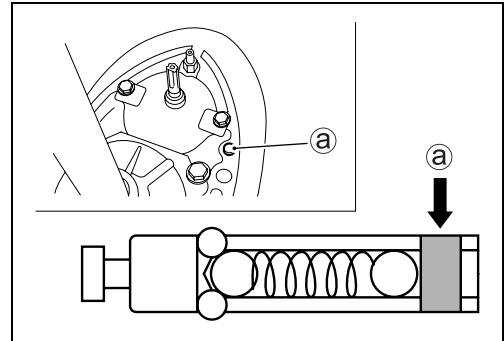

- Insert the connector pin ③ (w/detent balls) into propeller shaft ①.
- Align the holes in the shifter dog and connector pin and then slide the dog pin ⑧ through both dog and connector pin. (save the temporarily installed dowel pin pushed out as the dog pin is inserted.)
- Install the dog pin retaining spring ⑩, ensuring that it fits snugly into the groove on the dog shifter.

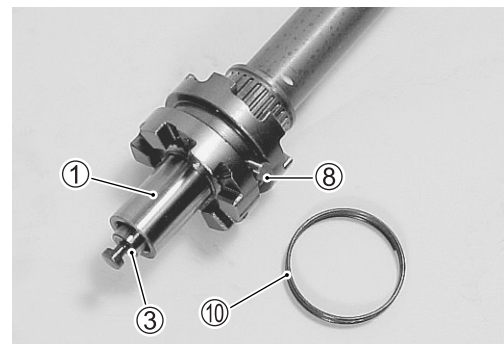

PROPELLER SHAFT/BEARING HOUSING

- Assemble the propeller shaft in the following sequence: forward thrust washer ⑤, reverse thrust washer ①, reverse gear ②, reverse gear back-up shim ③ and propeller shaft housing ④.

W/R G's 99000-25160: SUZUKI WATER RESISTANT GREASE

Gear OIL 99000-22540: SUZUKI OUTBOARD MOTOR GEAR OIL

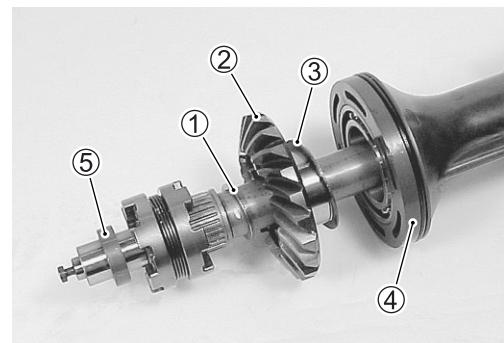

- Assemble horizontal slider ⑥ to connector pin.
- Apply Water Resistant Grease to bearing housing O-ring ⑦.

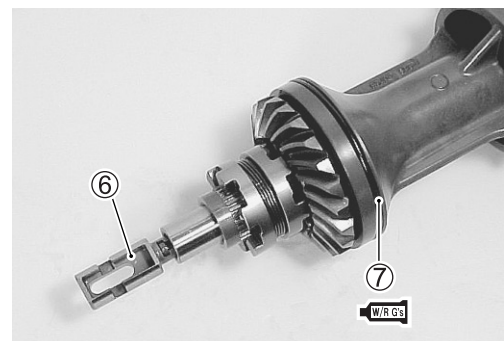

NOTE:

Before installing propeller shaft/bearing housing assembly, move shifter dog to bring horizontal slider to the neutral position.

- Using special tools, install the propeller shaft and housing assembly in the gear case.

TOOL 09922-59410: Propeller shaft housing installer
 09922-59420: Housing installer handle

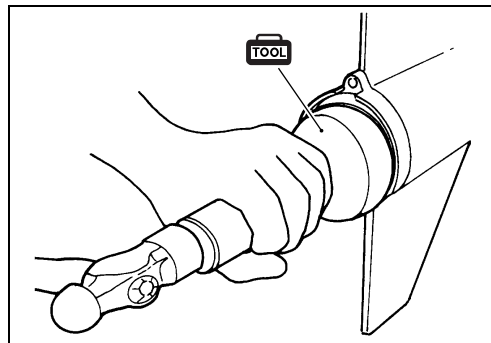

- When the housing is fully seated, tighten both retaining bolts to the specified torque.

U Bearing housing bolt: 23 N·m (2.3 kg·m, 16.6 lb·ft)

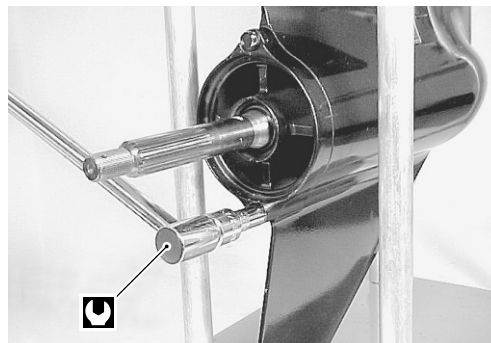

RECHECKING GEAR BACKLASH

Recheck the gear backlash.

This should not be less than previously checked.

If less, reduce the number/thickness of reverse gear back-up shims.

(See the “GEARS-SHIMMING AND ADJUSTMENT/CHECKING BACKLASH” section on page 9-30.)

TOOL 09952-09310: Backlash indicator tool

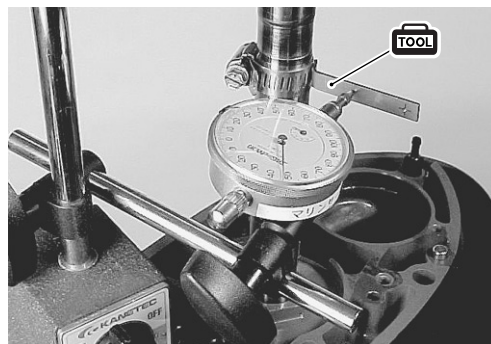

CHECKING PROPELLER SHAFT THRUST PLAY

See the “GEARS-SHIMMING AND ADJUSTMENT/CHECKING PROPELLER SHAFT THRUST PLAY” section on page 9-31.

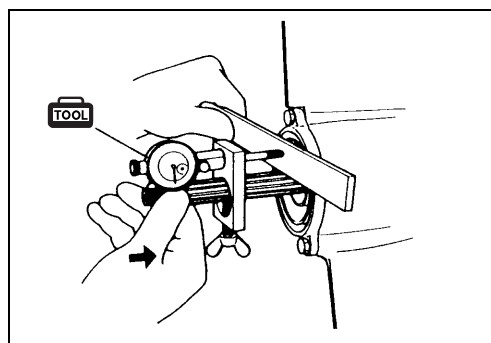

SHIFT ROD GUIDE HOUSING

- Using an oil seal installer, drive the oil seal ① into the shift rod guide housing ②.
 The lipped portion of oil seal must face towards the driveshaft housing.

W/RG's 99000-25160: SUZUKI WATER RESISTANT GREASE

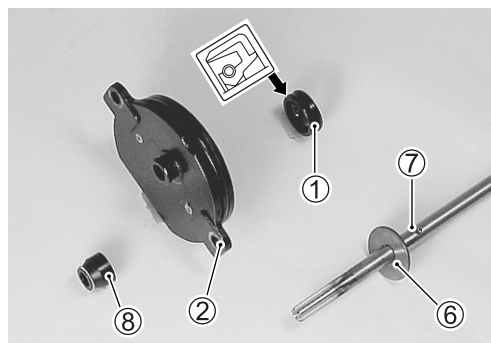

- Attach shifter yoke ④ to shift rod ③, then insert pin ⑤.
- Install pin ⑦ and washer ⑥ to shift rod, then slide shift rod guide housing onto shift rod.
- Install dust seal ⑧ to shift rod guide housing.

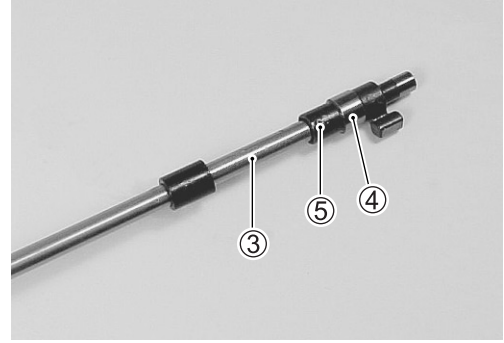

NOTE:

Be sure the horizontal slider is in the neutral position before installing the shift unit (shift rod guide housing assembly.).

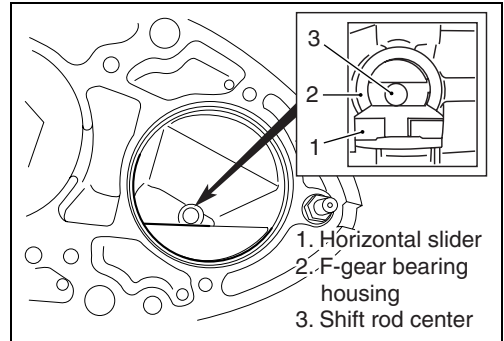

- Apply Water Resistant Grease to the shift rod guide housing O-ring.

WRG's 99000-25160: SUZUKI WATER RESISTANT GREASE

NOTE:

Before installing shift rod guide housing assembly, bring shifter yoke to neutral position by turning shift rod right or left.

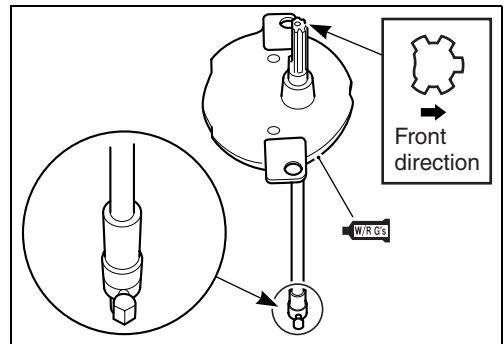

- Install shift rod guide housing assembly by aligning shifter yoke with groove in horizontal slider, then tighten two (2) housing bolts securely.
- Turn shift rod from Neutral position to Forward and Reverse position to check proper gear engagement.

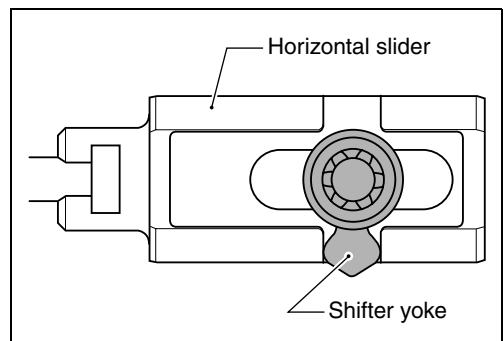
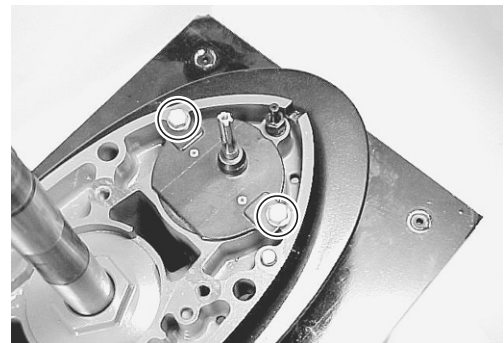

LEAKAGE CHECK

Check for leakage of oil seal and O-ring when applying specified pressure inside of the gearcase.

TOOL 09950-69511: Oil leakage tester
09952-99310: Air pump

Procedure

1. Install the test tool into the oil drain hole.
2. Connect the air pump to the tester.
3. Rotate driveshaft and propeller shaft clockwise several times and then apply specified pressure for the test.

NOTE:

Apply low initial pressure of 20 – 40 kPa, (0.2 – 0.4 kg/cm², 2.8 – 5.7 psi) first, then apply specified pressure.

Leakage test pressure: 100 kPa (1.0 kg/cm², 14.2 psi)

CAUTION

Do not exceed pressure of 110 kPa (1.1kg/cm², 15.6 psi) or damage to oil seals will result.

4. Once stabilized, pressure should remain steady for at least 5 min.
If pressure does not fall, sealing performance is correct.

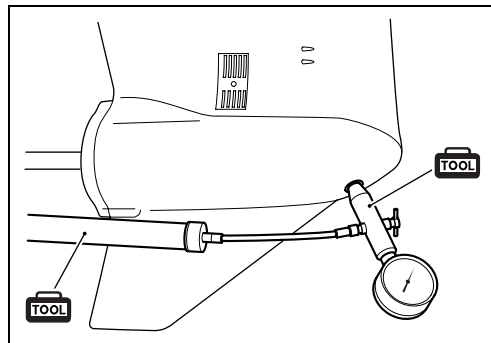

WATER PUMP (Impeller & case)

- Place the dowel pins ①, under panel gasket ② and under panel ③ into position.
- Insert the key ④ in the driveshaft and slide the impeller ⑤ onto driveshaft, ensuring that key and keyway are aligned.

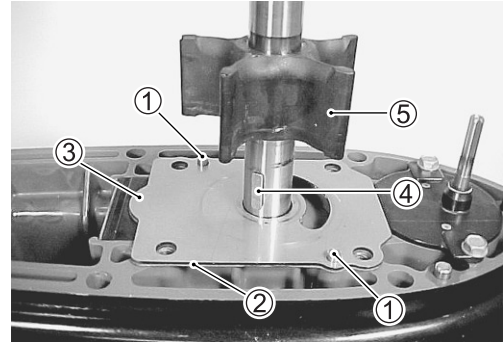

- Place the seal ring ⑦ into groove of the pump case ⑥, then install inner sleeve ⑧ to pump case.

CAUTION

**Do not re-use seal ring once removed.
Always use new ring.**

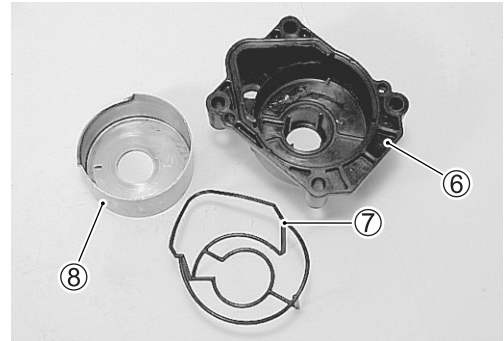

NOTE:

Before installing pump inner sleeve, apply water resistant grease lightly between inner sleeve and pump case mating surfaces.

W/R G's 99000-25160: SUZUKI WATER RESISTANT GREASE

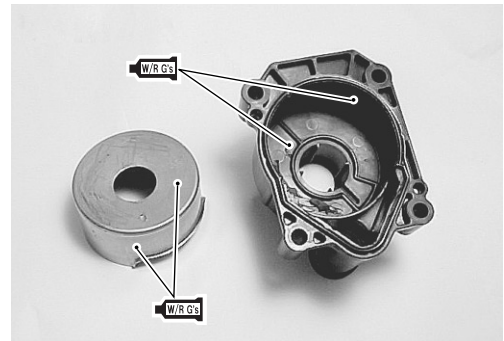

NOTE:

Before installing water pump case assembly, apply Water Resistant Grease lightly on pump case inner sleeve and under panel for initial lubrication.

W/R G's 99000-25160: SUZUKI WATER RESISTANT GREASE

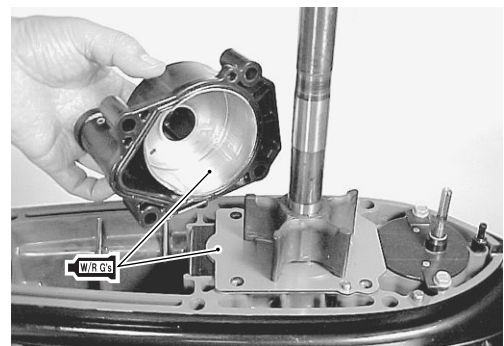

- Install the pump case assembly ⑨ while rotating driveshaft clockwise to flex the impeller vanes in the correct direction.
- Securely tighten the four (4) pump case bolts ⑩ to the specified torque.

🔩 Pump case bolt: 17 N·m (1.7 kg·m, 12.5 lb·ft)

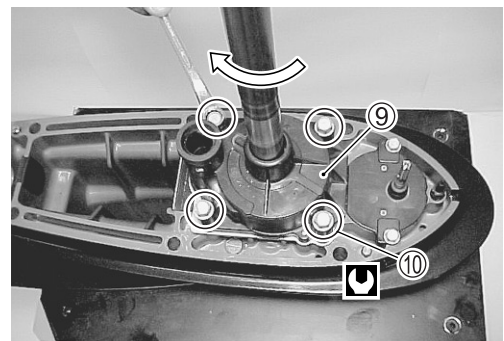

PROPELLER INSTALLATION

Install propeller stopper ① onto propeller shaft, then slide on the propeller ②.

Fit spacer ③, washer ④ and nut ⑤, then tighten nut to specified torque.

Push cotter pin ⑥ through nut and shaft, then bend to secure.

 99000-25160: SUZUKI WATER RESISTANT GREASE

 Propeller nut: 55 N·m (5.5 kg·m, 40.0 lb·ft)

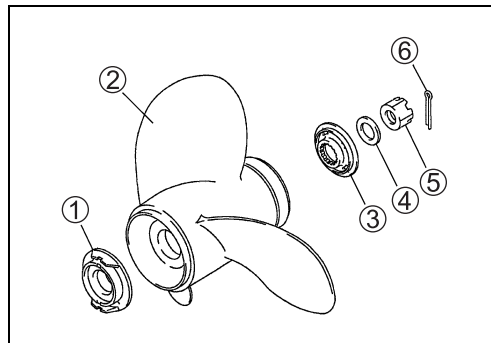

LOWER UNIT INSTALLATION

- Apply Water Resistant Grease to clutch rod splines, then install clutch rod ① by aligning clutch rod splines with splines in clutch shaft.

 99000-25160: SUZUKI WATER RESISTANT GREASE



- Ensure that shift rod ② is at neutral position.

NOTE:

Before installing lower unit assembly, bring shift to neutral position by turning shift rod right or left.

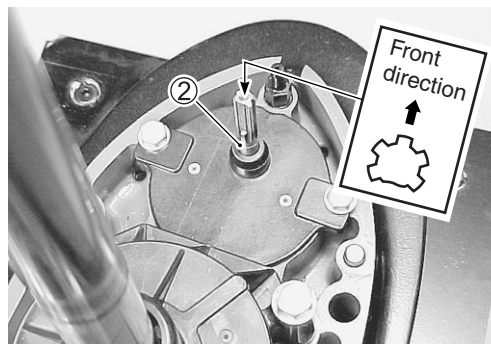

- Insert two (2) dowel pins ③.
- Apply Water Resistant Grease to driveshaft and shift rod splines.
- Apply a light coating of SUZUKI SILICONE SEAL to mating surfaces of gearcase and driveshaft housing.

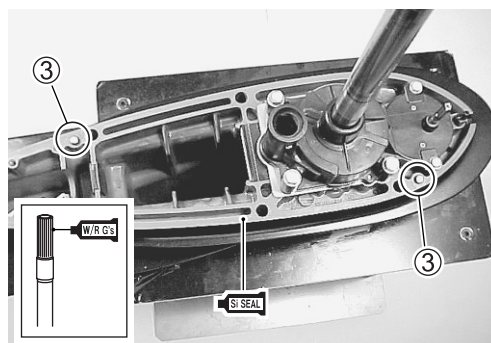

- Install spacer ④ to water tube.

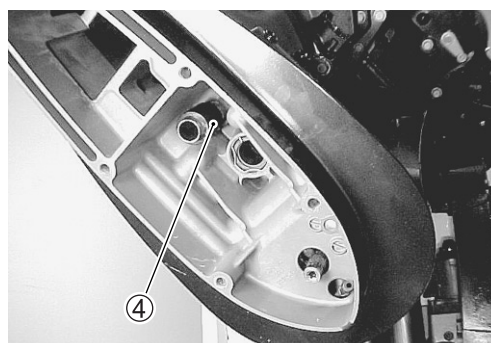

- Set the clutch control lever ⑤ at Neutral position, then slide the lower unit ⑥ into place, ensuring that the top of driveshaft engages properly with driven gear shaft and that water tube locates in water pump case outlet.

NOTE:

In order for shift rod and clutch rod splines to be aligned correctly, clutch rod may need to be turned slightly right or left.

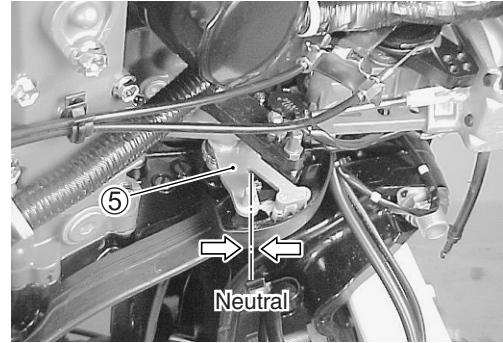

- Apply SUZUKI SILICONE SEAL to seven (7) gearcase bolts ⑦ and tighten them to specified torque.

Gearcase bolt: 10 mm 54 N·m (5.5 kg-m, 40.0 lb-ft)
12 mm 83 N·m (8.3 kg-m, 60.0 lb-ft)

W/R G's 99000-25160: SUZUKI WATER RESISTANT GREASE

SI SEAL 99000-31120: SUZUKI SILICONE SEAL

- Shift the clutch control lever to Forward and Reverse position from Neutral position to check proper gear engagement.

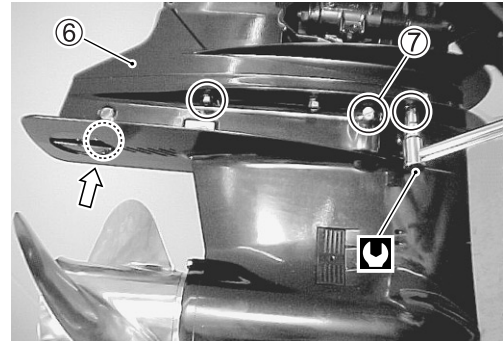

GEAR OIL

Fill the gearcase with specified gear oil for initial testing and recheck the level after 10 minutes. Top up if necessary.

(See “PERIODIC MAINTENANCE/GEAR OIL” section on page 2-6.)

Gear Oil 99000-22540: SUZUKI OUTBOARD MOTOR GEAR OIL

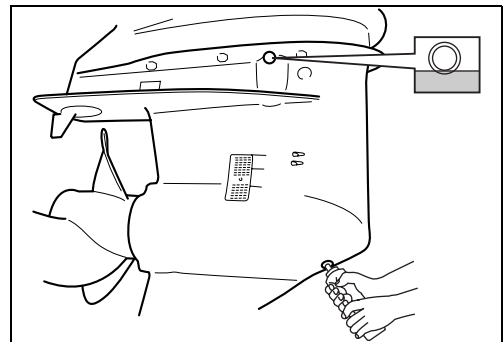

TRIM TAB

The trim tab counteracts or minimizes propeller torque “pull” felt through the steering system.

If the steering is pulled to starboard or port side, adjust trim tab with following procedure:

Adjusting

1. Loosen the bolt of trim tab.
2. Change direction of trim tab.
 - To compensate for a veer to starboard, set trailing edge of tab to the right (as viewed from behind).
 - To compensate for a veer to port, set trailing edge of tab to the left.
3. Tighten the bolt of trim tab.
4. Test ride the boat and repeat the procedure 1 – 3 to set the trim tab in the best position.

With a properly adjusted trim tab, steering should be neutral and there should be no tendency for the steering to be pulled to either port or starboard.

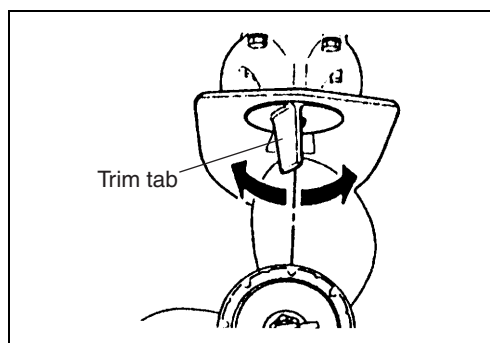
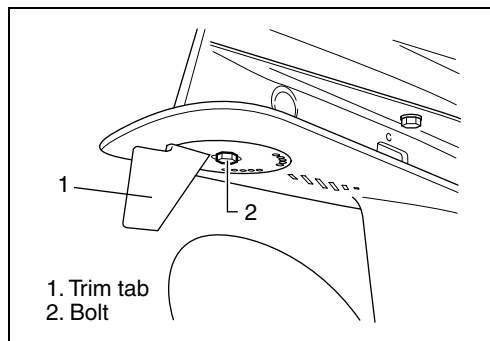

LOWER UNIT GEARS- SHIMMING AND ADJUSTMENT

If lower unit has been rebuilt or has had components replaced, shimming for correct gear contact and backlash will have to be adjusted to ensure smooth, reliable operation of gears.

Shim/Washer & Mounting position

	Numerical index/item	Available thickness (mm)	Design specification Thickness (mm)
①	Pinion gear back-up shim	0.45, 0.50, 0.55, 0.60, 0.65, 0.70, 0.75, 0.80, 0.85, 0.90	1.0
②	Forward gear back-up shim	0.50, 0.60, 0.65, 0.70, 0.75, 0.80, 0.85, 0.90, 0.95, 1.0	1.0
③	Forward gear thrust washer	9.5	9.5
④	Reverse gear thrust washer	1.5, 1.7, 1.9, 2.1, 2.2, 2.3, 2.4, 2.5, 2.6, 2.7, 2.8	2.0
⑤	Reverse gear back-up shim	1.0, 1.1, 1.2, 1.3, 1.4, 1.5, 1.6, 1.7	1.5

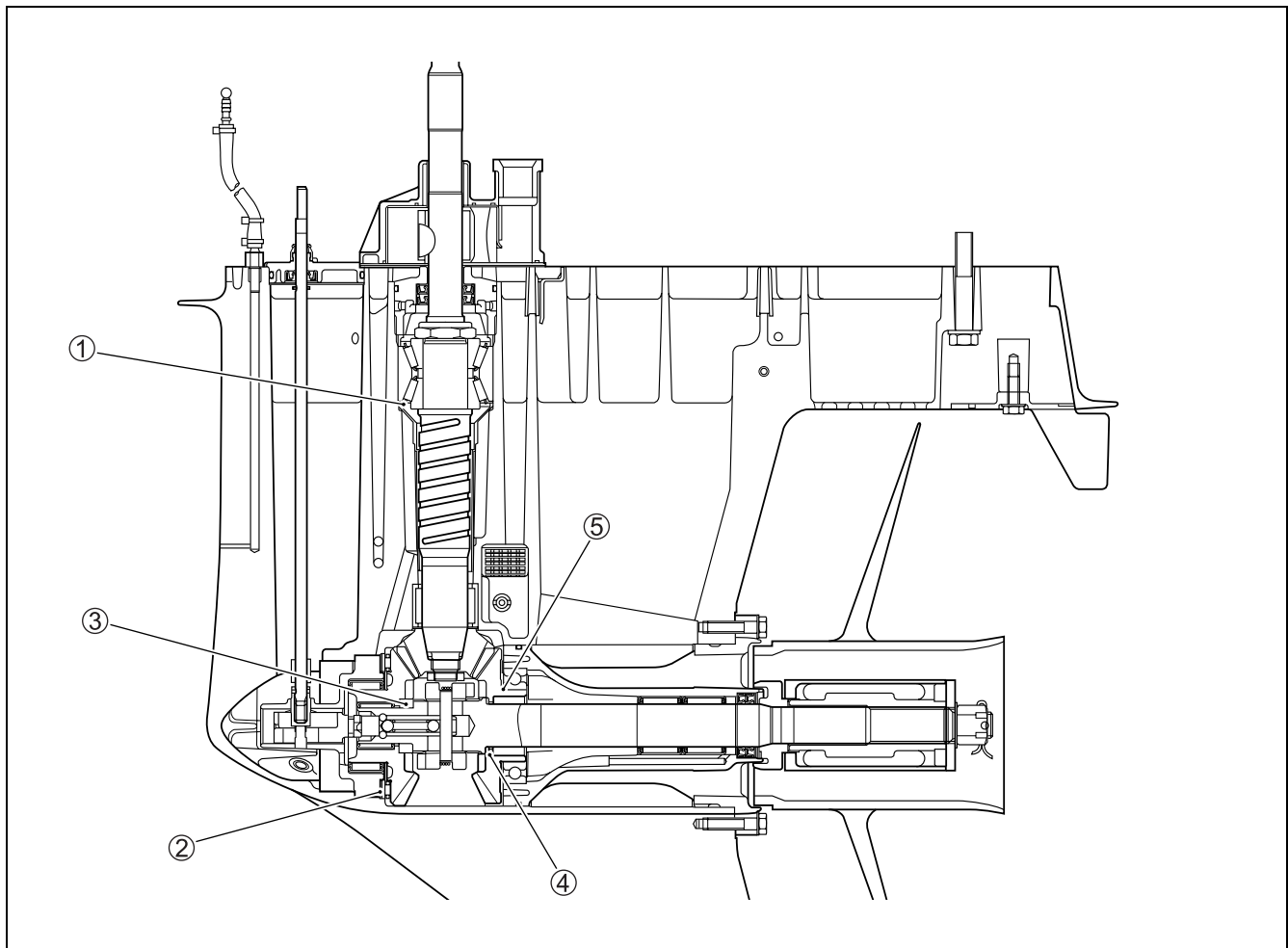

FORWARD GEAR/PINION GEAR

Follow the procedure below to adjust forward gear/pinion gear.

Step to prior to adjustment

1. Install standard pinion gear back-up shim thickness modified according to \pm design specification mark on gear.

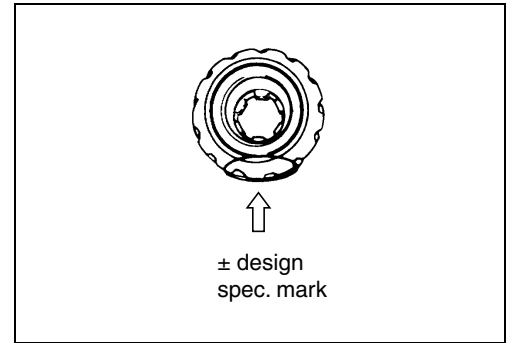

2. Correctly assemble driveshaft oil seal housing, driveshaft, forward gear, pinion gear and related components. (See page 9-15 to 9-17.)
Do not install reverse gear at this time.
3. Tighten pinion nut to specified torque.

 **Pinion nut : 144 N·m (14.4 kg·m, 104 lb·ft)**

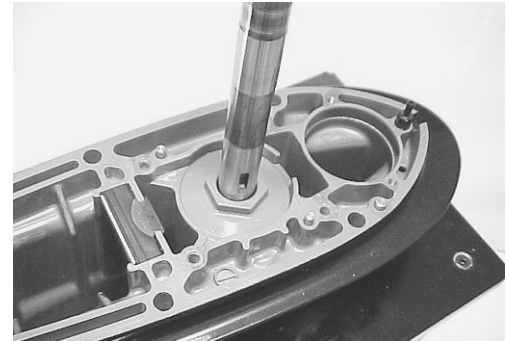

Adjusting gear backlash

- (a) Assemble special tool to driveshaft as shown in figure.

 **09900-20606: Dial gauge**
09900-20701: Magnetic stand
09952-09310: Backlash indicator tool

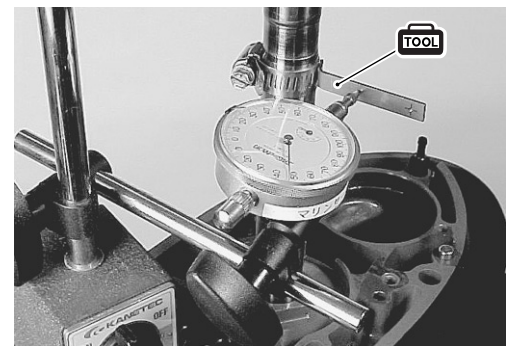

- (b) Push forward gear inward and hold it by hand, align dial gauge pointer at 90 ° to the mark on the backlash indicator tool and read backlash on dial gauge by lightly moving driveshaft clockwise and counterclockwise by hand.

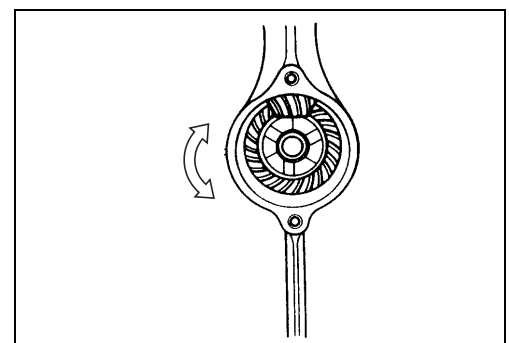

Gear backlash: Approx. 0.3 – 0.5 mm (0.012 – 0.020 in)

- If the backlash measured is larger than the specification, add the amount over the specification to the temporary use forward gear back-up shim and install this shim.
- If the backlash measured is smaller than the specification, subtract the amount less than the specification from the temporary use forward gear back-up shim and install this shim.

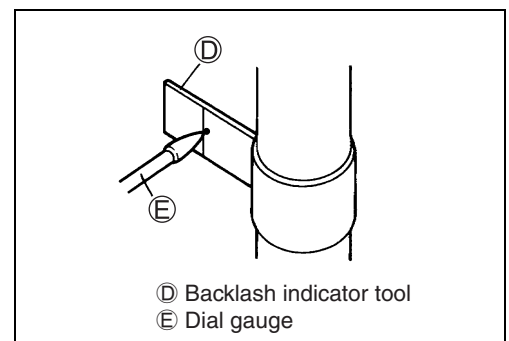

**Checking and adjusting tooth contact pattern
(Pinion and Forward gear)**

Check tooth contact pattern using the following procedure:

1. To assess tooth contact, apply a light coat of Prussian Blue on the convex surface of forward gear.
2. Install propeller shaft and housing assembly (minus reverse gear and internal components).
3. Push propeller shaft inward and hold in position.
4. Using driveshaft holder tool, rotate the driveshaft 5 – 6 times.

 **09921-29410 : Driveshaft holder**

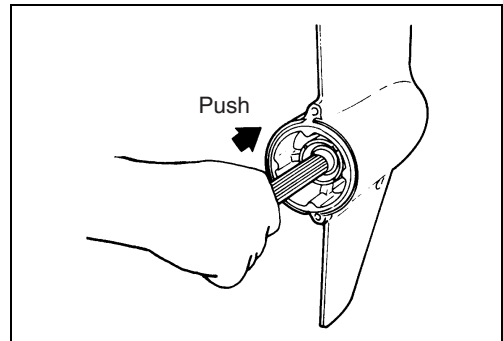

5. Carefully pull out propeller shaft and housing to check tooth contact pattern.

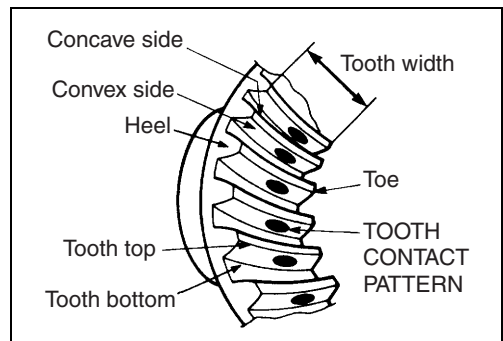

Optimum tooth contact

The optimum tooth contact is shown at right. A shim adjustment may be necessary to obtain this contact pattern.

CAUTION

Gear backlash should be checked when increasing or decreasing shim thickness to adjust tooth contact.

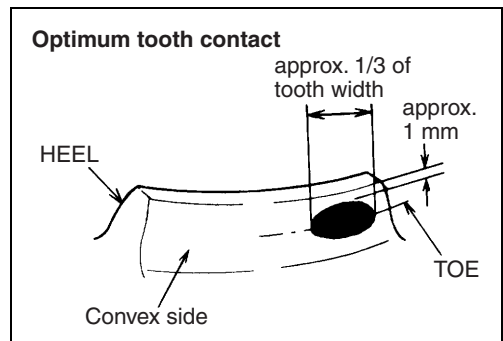

Example (1)

Incorrect topside toe contact:

Correction measures:

- Decrease thickness of forward gear shim.
- Slightly decrease pinion gear shim thickness.

CAUTION

Do not set tooth contact in this position (top side toe contact). Damage and chipping of forward and pinion gear may result.

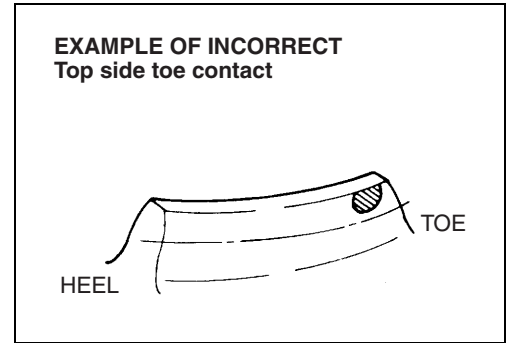

Example (2)

Incorrect bottom side toe contact:

Correction measures:

- Increase thickness of forward gear shim.
- Slightly increase pinion gear shim thickness.

CAUTION

Do not set tooth contact in this position (bottom side toe contact). Chipping of pinion gear may result.

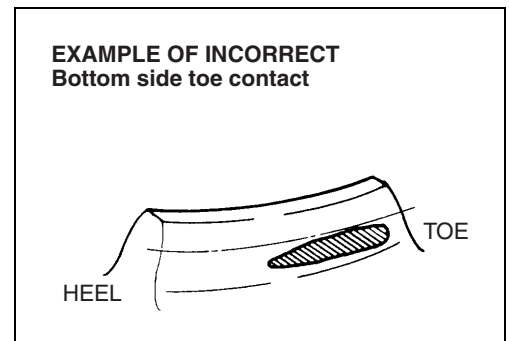

CHECKING GEAR BACKLASH

After obtaining optimum tooth contact, gear backlash should be measured.

(a) Assemble special tool as shown in figure.

-  **09900-20606 : Dial gauge**
- 09900-20701 : Magnetic stand**
- 09900-09310 : Backlash indicator tool**

(b) Push the forward gear inward and fix it by hand, then read backlash on dial graduation by lightly moving driveshaft clockwise and counterclockwise by hand.

Designate this amount of gear backlash as (A).

Gear backlash: Approx. 0.3 – 0.5 mm (0.012 – 0.020 in)

NOTE:

Gear backlash (A) must be known to adjust reverse gear shim.

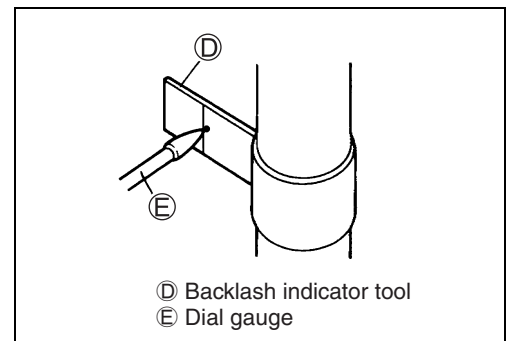
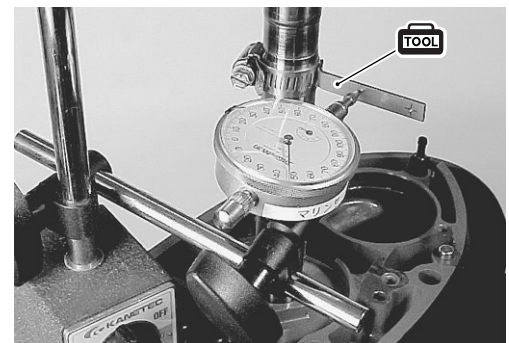

RECHECKING GEAR BACKLASH

(Reverse gear back-up shim adjustment)

1. After adjusting forward gear tooth contact pattern, correctly assemble propeller shaft, housing assembly, reverse gear and related components. (See page 9-17 to 9-19.)
2. Thread slide hammer assembly onto propeller shaft and strike a few gentle outward taps.

TOOL 09930-30161 : Propeller shaft remover – (B)
 09930-30102 : Sliding hammer – (A)

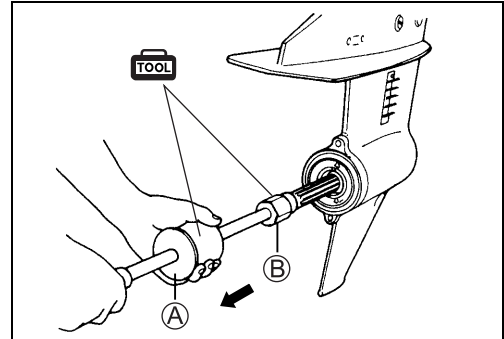

3. Assemble special tool in the following sequence.

TOOL 09951-99310 : Gear holder

- (a) Remove two (2) bearing housing retaining bolts, then screw long bolts of special tool to secure the bearing housing.
 - (b) Install the special tool and then attach it to the propeller shaft as shown.
4. Turn the bolt ① counterclockwise and tighten until the propeller shaft can rotate smoothly without play. Do not over tighten.

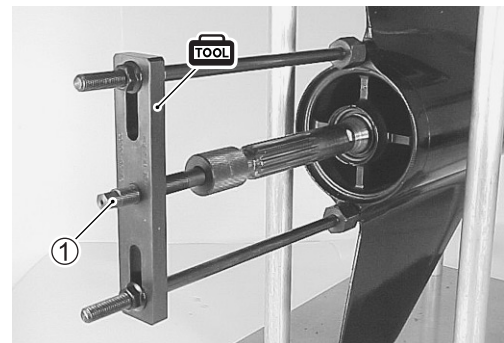
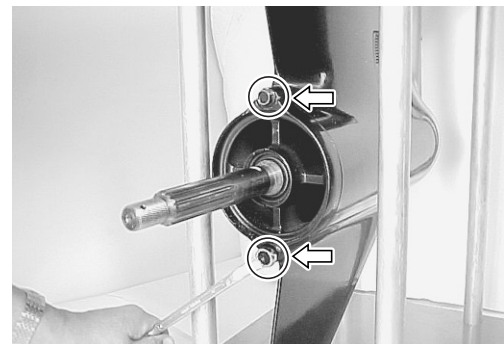

5. Assemble backlash indicator tool and dial gauge as shown in figure.

TOOL 09900-20606 : Dial gauge
 09900-20701 : Magnetic stand
 09952-09310 : Backlash indicator tool

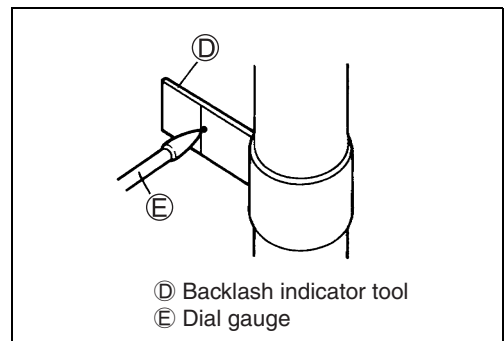

6. Read backlash on dial gauge by lightly moving driveshaft clockwise and counterclockwise by hand.
Designate this measurement as backlash (B).
7. Compare backlash (B) to backlash (A) (page – 9-29.).
8. Reverse gear back-up shim adjustment is correct if (B) is equal to (A).
 - If (B) is less than (A), reduce reverse gear back-up shim thickness .

CHECKING PROPELLER SHAFT THRUST PLAY

After adjusting all gear positions, measure the propeller shaft thrust play. If not within the following specification, a shim adjustment is required.

Propeller shaft thrust play : 0.2 – 0.4 mm (0.008 – 0.016 in)

NOTE:

*Use only the reverse gear thrust washer to adjust thrust play.
The forward gear thrust washer must be maintained at standard thickness (9.5 mm).*

Measurement step :

1. Assemble gear adjusting gauge to the propeller shaft.

09951-09511: Gear adjusting gauge

2. Push propeller shaft inward.
3. Hold shaft in and set dial gauge pointer to zero.
4. Slowly pull shaft outward and read the maximum thrust play on the dial gauge.
 - If measurement is more than specification, increase reverse gear thrust washer thickness.
 - If measurement is less than specification, reduce reverse gear thrust washer thickness.

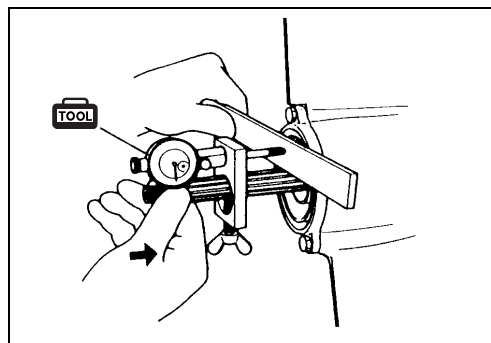

LOWER UNIT [Counter rotation (Left-hand) model]

CONTENTS

REMOVAL & DISASSEMBLY	10- 2
INSPECTION	10- 8
PROPELLER	10- 8
GEARCASE	10- 8
GEARS/BEARING	10- 9
REVERSE GEAR BEARING HOUSING/BEARING	10- 9
PROPELLER SHAFT COMPONENTS	10- 9
PROPELLER SHAFT BEARING HOUSING	10-10
SHIFT ROD GUIDE HOUSING COMPONENTS	10-11
WATER PUMP AND RELATED ITEMS	10-11
DRIVESHAFT OIL SEAL HOUSING	10-12
DRIVESHAFT	10-12
ASSEMBLY & INSTALLATION	10-13
TRIM TAB	10-25
LOWER UNIT GEARS- SHIMMING AND ADJUSTMENT	
(Counter rotation model)	10-26
REVERSE GEAR/PINION GEAR	10-27
FORWARD GEAR SHIM	10-28
CHECKING PROPELLER SHAFT THRUST PLAY	10-30

REMOVAL & DISASSEMBLY

⚠ WARNING

Always disconnect the battery cable, before removing lower unit.

Shift to "NEUTRAL" position.
Remove bolt and trim tab ①.

Remove seven (7) bolts ② and separate gearcase ③ from driveshaft housing.

NOTE:
Before gearcase is removed completely, disconnect speedometer pick up tube ④ from gearcase.

Remove water tube spacer ⑤.
Remove clutch rod ⑥ from clutch shaft (if necessary).

Place a drain pan under oil drain plug.
Remove oil drain plug ⑦ first then oil level plug ⑧ and allow gear oil to drain.
Inspect oil for water, contaminants or metal.

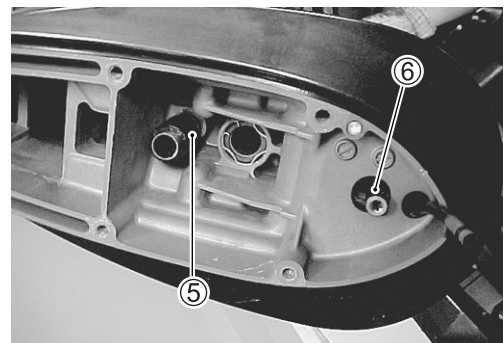
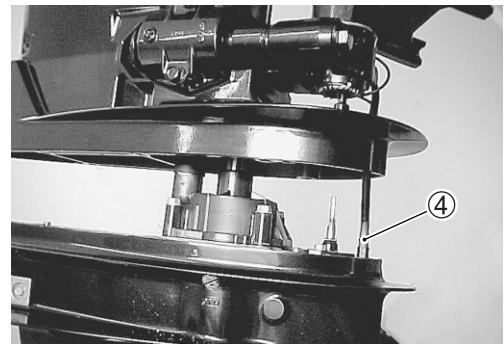
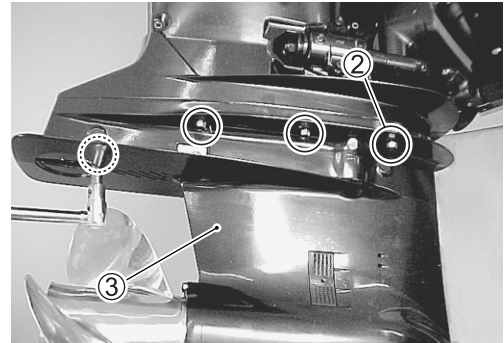
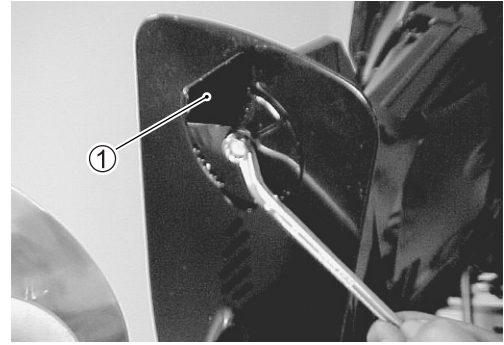

Remove cotter pin ① from propeller nut and remove propeller nut ②.

Remove washer ③, spacer ④, propeller ⑤ and stopper ⑥ from the propeller shaft.

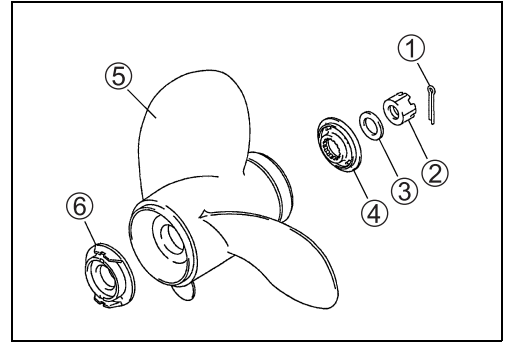

⚠ WARNING

To prevent injury from propeller blades, wear gloves and place a block of wood between the anti-cavitation plate and the propeller blade tips to lock the propeller in place before attempting to remove propeller nut.

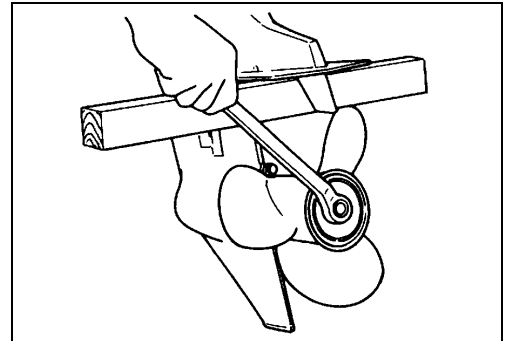

Loosen four (4) bolts ①, then remove water pump case ②.

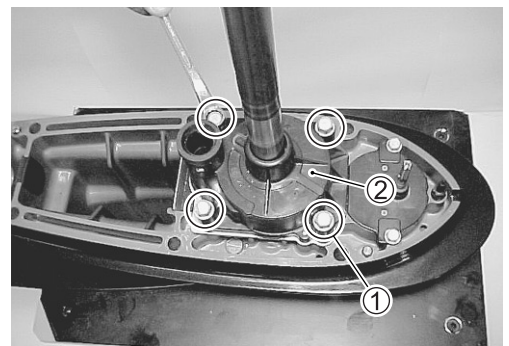

Remove impeller ③, impeller key ⑥, pump under plate ④ and dowel pins ⑤.

Keep impeller key ⑥ for reuse and discard the plate gasket.

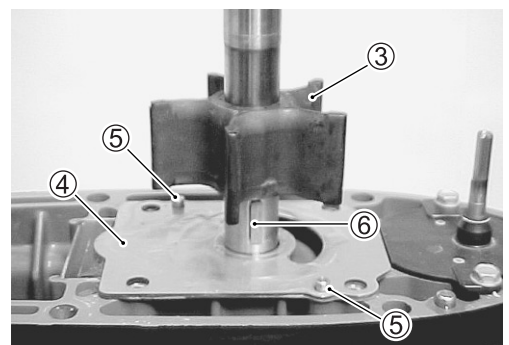

Remove two (2) bolts ① and shift rod guide housing assembly ②.

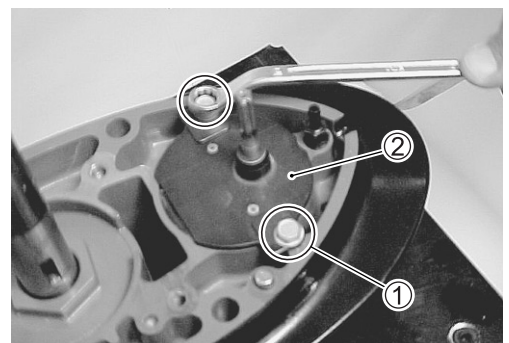

Remove two (2) bolts ① securing the propeller shaft bearing housing to the gearcase.

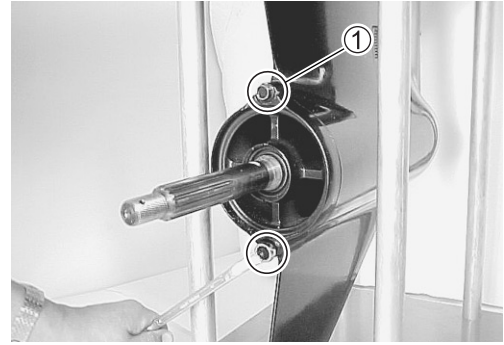

Using special tools, pull out the propeller shaft bearing housing. Remove the propeller shaft and bearing housing assembly ②.

- TOOL 09930-30102: A Sliding hammer**
- 09930-30161: B Propeller shaft remover**

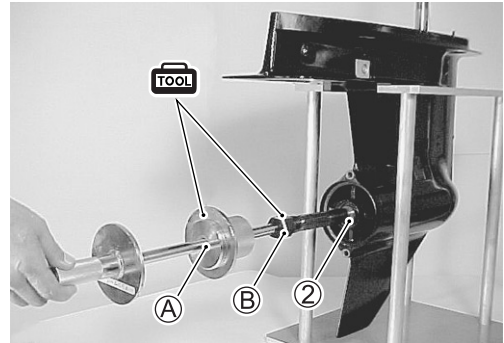

Hold the pinion nut securely, then fit special tool to the driveshaft and loosen the pinion nut. Remove pinion nut ③ and washer ④.

- TOOL 09921-29410: Driveshaft holder**

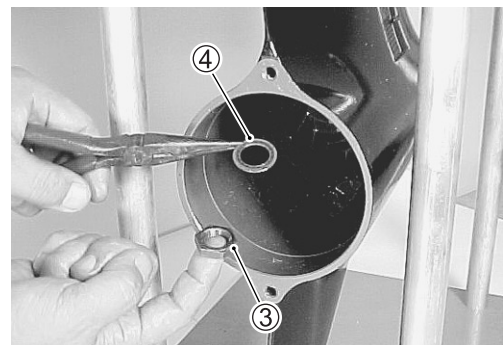
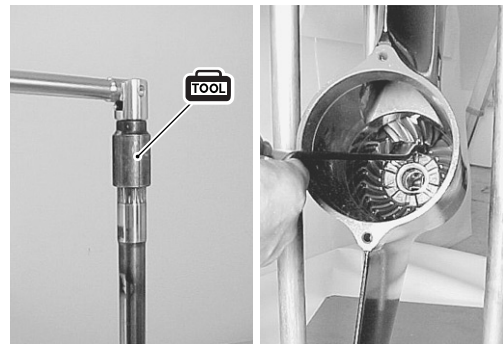

Use special tool to unscrew driveshaft oil seal housing ①, then remove oil seal housing from drive shaft.

- TOOL 09926-29310: Driveshaft housing remover**

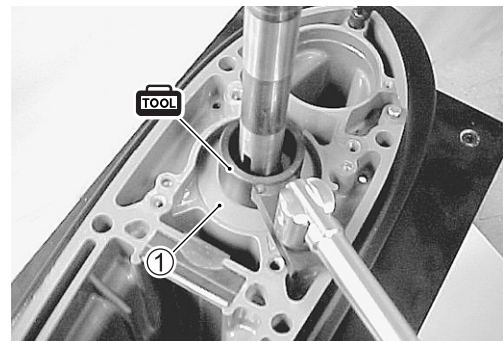

Remove driveshaft bearing spacer ②.

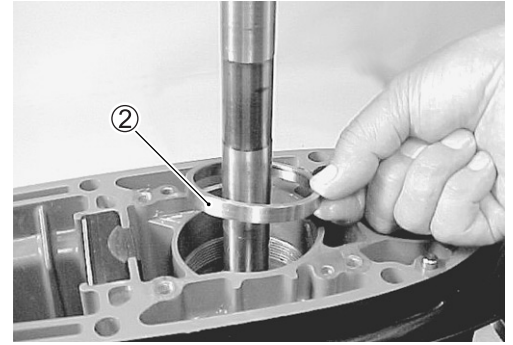

Slowly lift out driveshaft assembly ③.

Remove the pinion shim ④.

NOTE:

The driveshaft pinion gear bearing contains 28 loose roller bearings. Account for all roller bearings on disassembly.

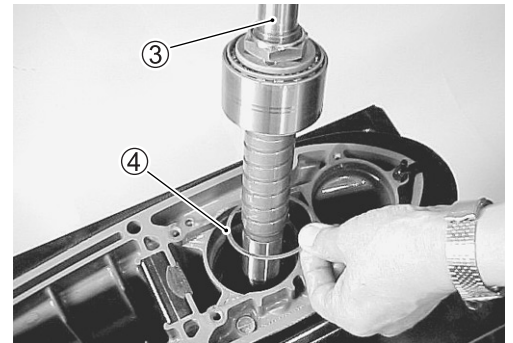

Remove the driveshaft collar ⑤.

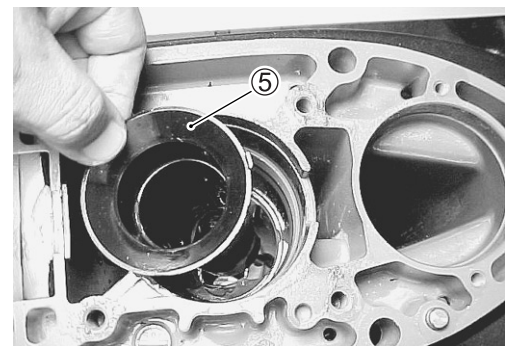

Remove the pinion gear ①.

Remove the reverse gear ② (with reverse gear bearing housing and thrust bearing).

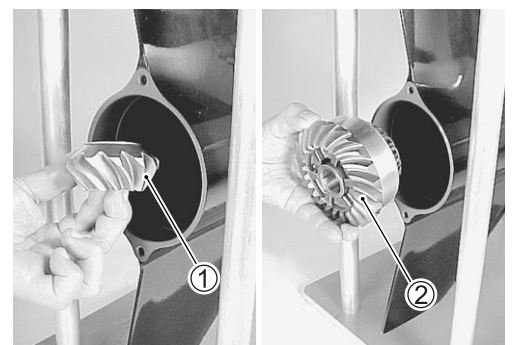

Remove the thrust bearing ③, reverse gear bearing housing ④ and back-up shim ⑤ from reverse gear.

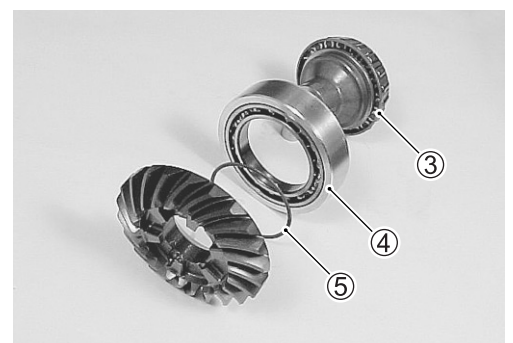

Disassembly of propeller shaft components

Slide propeller shaft away from forward gear ① and bearing housing assembly ②.

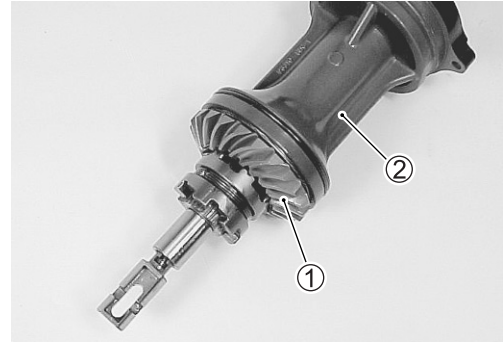

Remove the forward gear ③, forward gear thrust bearing ④, forward gear thrust washer ⑤, forward gear back-up shim ⑥.

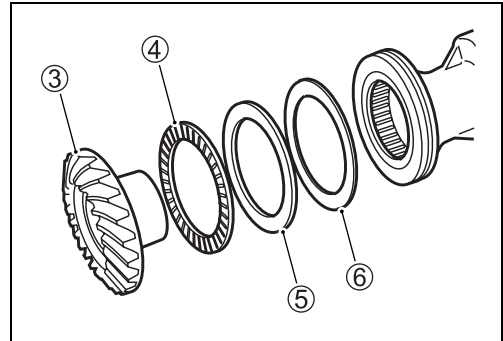

Remove the propeller shaft thrust washer ⑦, propeller shaft thrust bearing ⑧, bearing washer ⑨ and shim ⑩ from propeller shaft bearing housing.

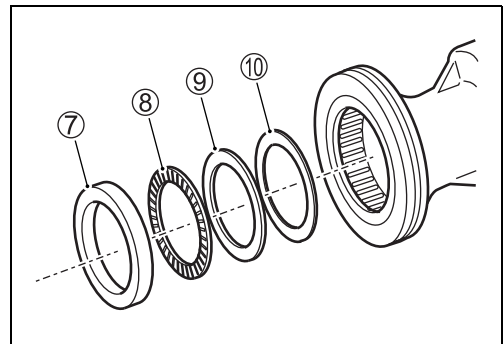

To disassemble propeller shaft components, refer to following:

- (a) Remove horizontal slider ⑪.
- (b) Remove spring ⑫ from clutch dog shifter.

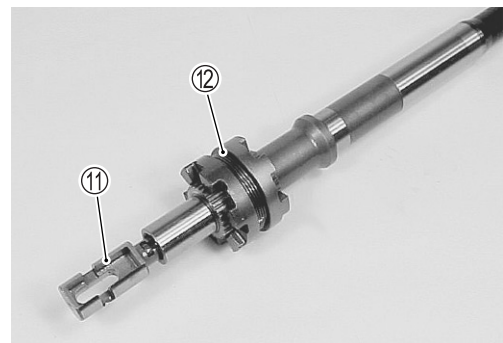

(c) Use special tool to push the dog pin ⑬ out of the clutch dog shifter.

 **09922-89810: Shift pin remover**

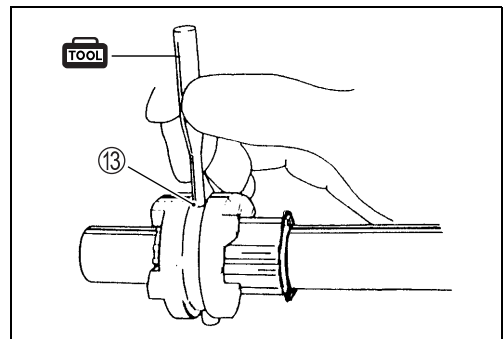

- (d) Remove clutch dog shifter ⑭ and connector pin ⑮ from propeller shaft.

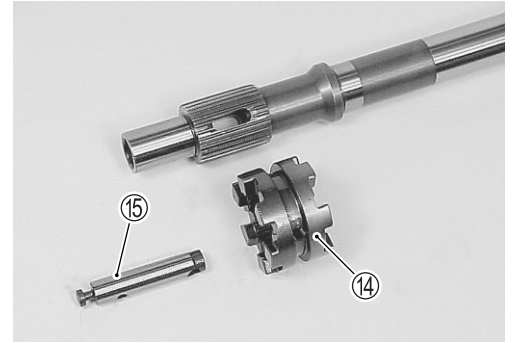

- (e) Remove large detent ball ⑯, detent spring ⑰, large detent ball ⑱ and two (2) small detent balls ⑲ from connector pin.

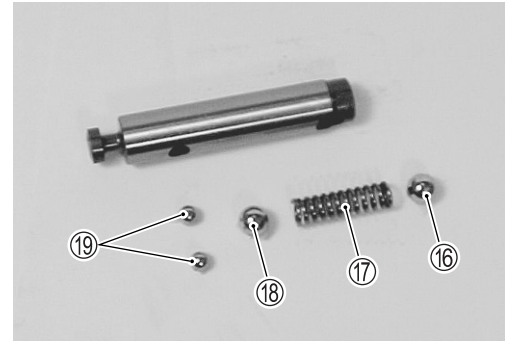

Disassembly of shift rod components

- (a) Remove dust seal ①.
 (b) Slide shift rod ② out of shift rod guide housing ③.

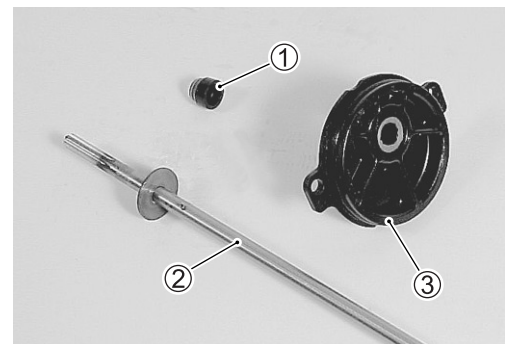

- (c) Remove pin ④ and shifter yoke ⑤.

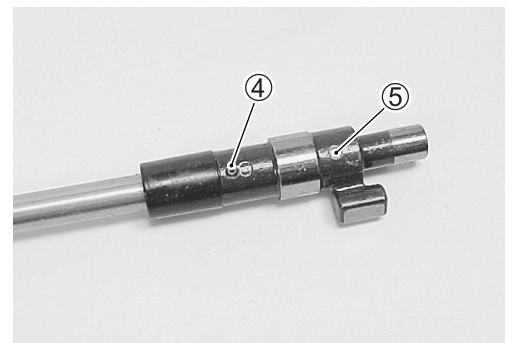

Disassembly of water pump case

Remove inner sleeve ① and rubber seal ring ②.

NOTE:

To facilitate the removal of inner sleeve from the pump case, warm up the entire case using a heater like hair dryer.

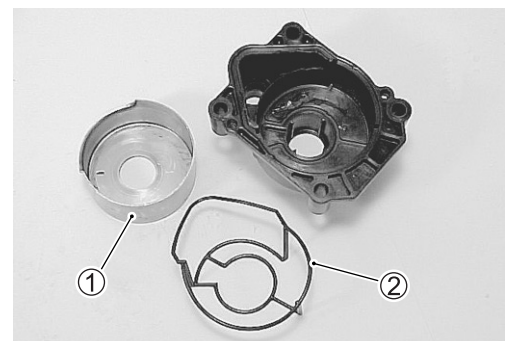

INSPECTION

NOTE:

If any component is worn excessively, cracked, defective or damaged in any way, it must be replaced.

NOTE:

Thoroughly wash all metal components with cleaning solvent and dry with compressed air.

⚠ WARNING

Wear safety glasses when using compressed air.

PROPELLER

- Inspect propeller for bent, chipped or broken blades. Replace or repair propeller if in damaged condition.
- Inspect propeller bush splines. Replace or repair propeller if splines are worn or damaged.
- Inspect propeller bush for deterioration or slipping. Replace if necessary.

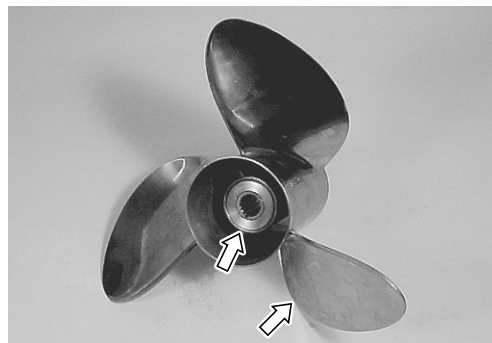

GEARCASE

- Inspect the gearcase. Replace if cracked, damaged or other abnormal condition.
- Visually check the pinion bearing. Replace gearcase if pitted, rough or other abnormal condition.
- Visually check shift cam housing. Replace gearcase if cracked, damaged, or other abnormal condition.



GEARS/BEARING

- Inspect forward, reverse and pinion gear teeth and engaging dogs.
Replace gears if damaged, worn or other abnormal condition.
- Inspect forward gear thrust bearing.
Replace bearing if pitted, noisy, rough or other abnormal condition.

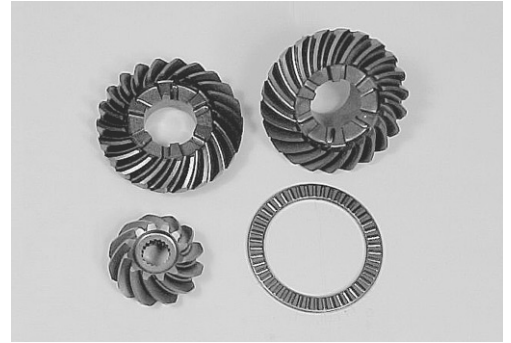

REVERSE GEAR BEARING HOUSING/BEARING

- Inspect reverse gear bearing housing.
Replace if cracked, damaged or other abnormal condition.
- Visually check bearing. Replace if pitted, noisy, rough or other abnormal condition.



PROPELLER SHAFT COMPONENTS

- Inspect horizontal slider and connector pin.
Replace if worn, damaged or other abnormal condition.
- Inspect clutch dog shifter. Replace if chipped, worn, damaged or other abnormal condition.
- Inspect dog pin. Replace if bent, worn or other abnormal condition.
- Inspect detent balls. Replace if wear, damage or other abnormal condition.
- Inspect propeller shaft/splines. Replace if worn, twisted, damaged or other abnormal condition.

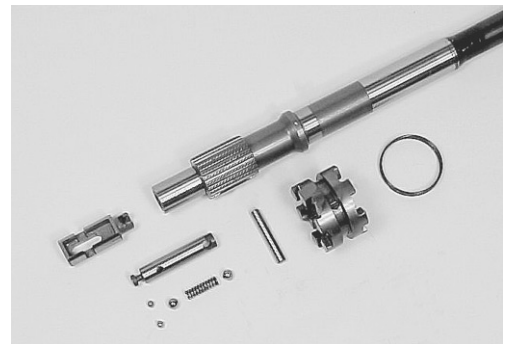

- Check detent spring by measuring its free length. If free length is not within specifications, replace detent spring.

Detent spring free length (L)

Standard: 27.8 mm (1.09 in)

Service limit: 25 mm (0.98 in)

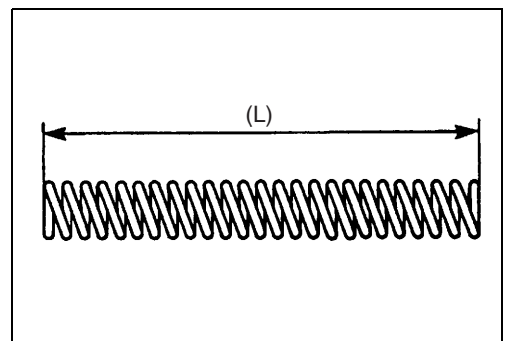

PROPELLER SHAFT BEARING HOUSING

- Inspect housing. Replace if cracked, damaged or other abnormal condition.
- Inspect forward gear bearing, propeller shaft thrust bearing and propeller shaft bearing. Replace bearing if pitted, noisy, rough or other abnormal condition.
- Check condition of oil seal and O-ring.
Replace oil seal and O-ring if nicked, cut, worn or other abnormal condition.



Replacing propeller shaft oil seal

1. Extract seals ① with oil seal remover.

TOOL 09913-50121: Oil seal remover

CAUTION

**Do not reuse oil seal once removed.
Always use new oil seal.**

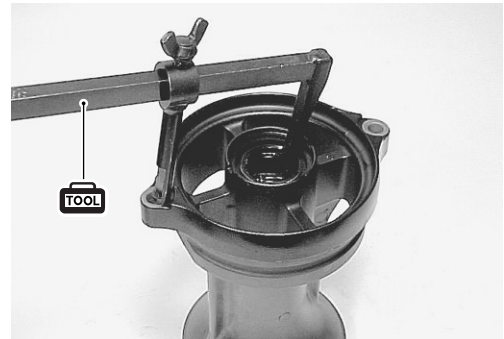

2. Apply Water Resistant Grease to the inner circumference of the housing.
3. Using an oil seal installer, drive the two oil seals (one at a time) into the propeller shaft bearing housing.
The lipped portion of the seal must face towards the propeller.
Apply Water Resistant Grease to the seal lips.

WRG's 99000-25160: SUZUKI WATER RESISTANT GREASE

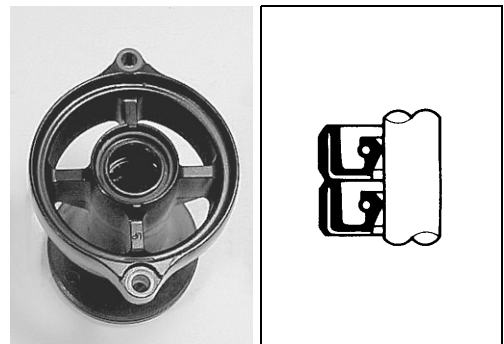

SHIFT ROD GUIDE HOUSING COMPONENTS

- Inspect shift rod guide housing. Replace if cracked, damaged or other abnormal condition.
- Inspect shifter yoke. Replace if wear, damaged or other abnormal condition.
- Inspect shift rod/splines. Replace if worn, twisted, damaged or other abnormal condition.
- Inspect O-ring. Replace if nicked, cut, torn, swollen or other abnormal condition.
- Inspect oil seal and dust seal. Replace if nicked, cut, worn or other abnormal condition.

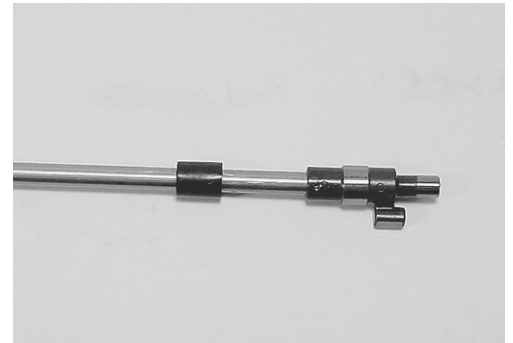
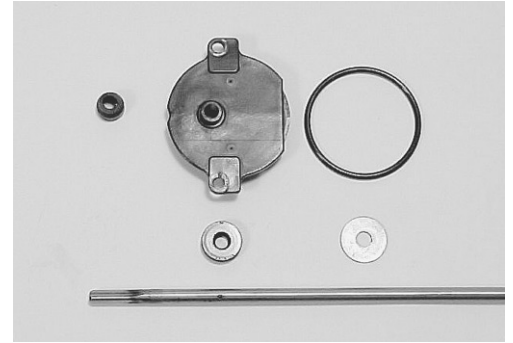

WATER PUMP AND RELATED ITEMS

- Inspect impeller. Replace if vanes are cut, torn, worn or other abnormal condition.
- Inspect pump case. Replace if cracked, distorted or other abnormal condition.
- Inspect pump inner sleeve. Replace if worn, cracked, distorted, corroded or other abnormal condition.
- Inspect seal ring. Replace if nicked, cut, torn, swollen or other abnormal condition.
- Inspect under panel. Replace if cracked, distorted, corroded or other abnormal condition.

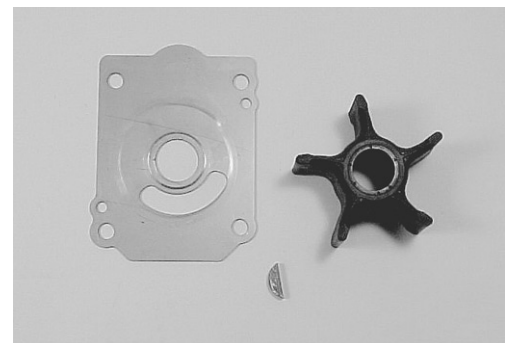
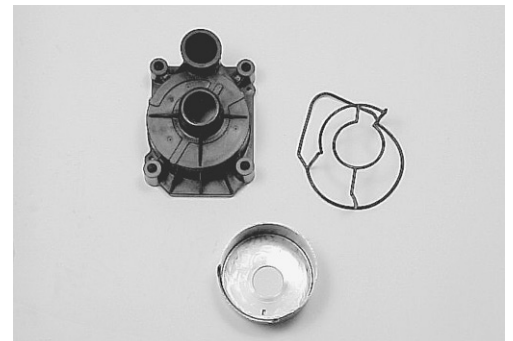

DRIVESHAFT OIL SEAL HOUSING

- Inspect housing. Replace if cracked, damaged or other abnormal condition.
- Check condition of oil seals. Replace if nicked, cut, worn or other abnormal condition.
- Inspect O-ring. Replace if worn, nicked, cut or other abnormal condition.

Replacing driveshaft oil seal

1. Using special tool, remove two (2) oil seals out of the driveshaft oil seal housing.

 **09913-50121: Oil seal remover**

2. Apply Water Resistant Grease to inner circumference of driveshaft oil seal housing.

 **99000-25160: SUZUKI WATER RESISTANT GREASE**

3. Grease the inner lips of oil seal. With the lips facing away from driveshaft bearing, place seal in position and drive it into the oil seal housing.

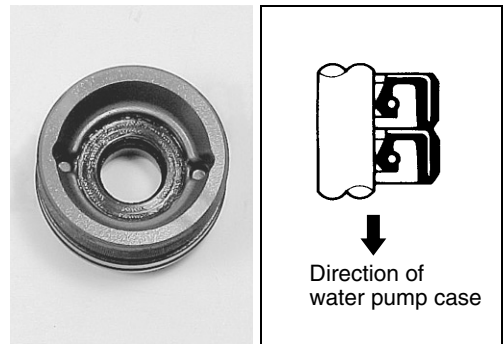
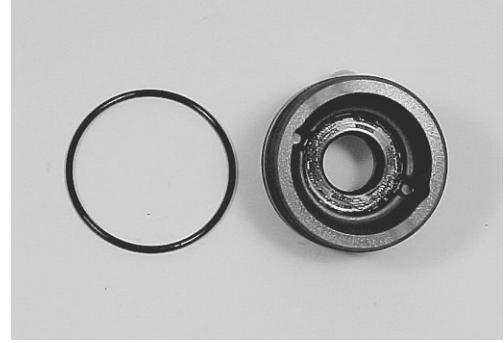

DRIVESHAFT

- Inspect driveshaft/splines. Replace if worn, twisted, damaged or other abnormal condition.
- Inspect driveshaft bearing, replace if pitted, noisy, rough or other abnormal condition.

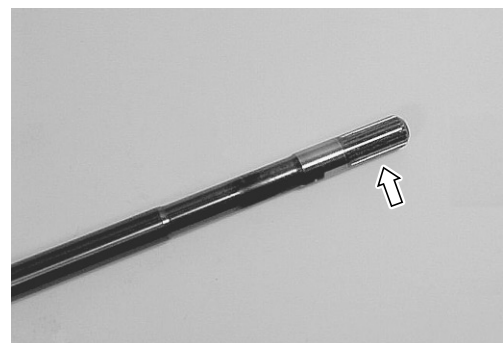
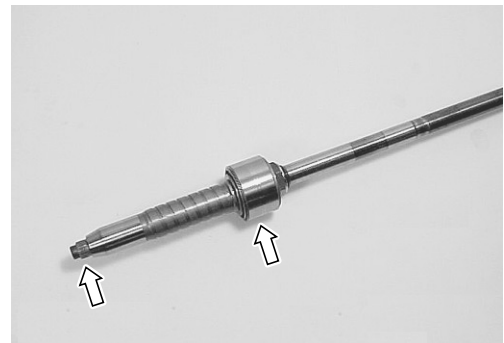

ASSEMBLY & INSTALLATION

Assembly & installation are reverse order of disassembly with special attention to the following steps.

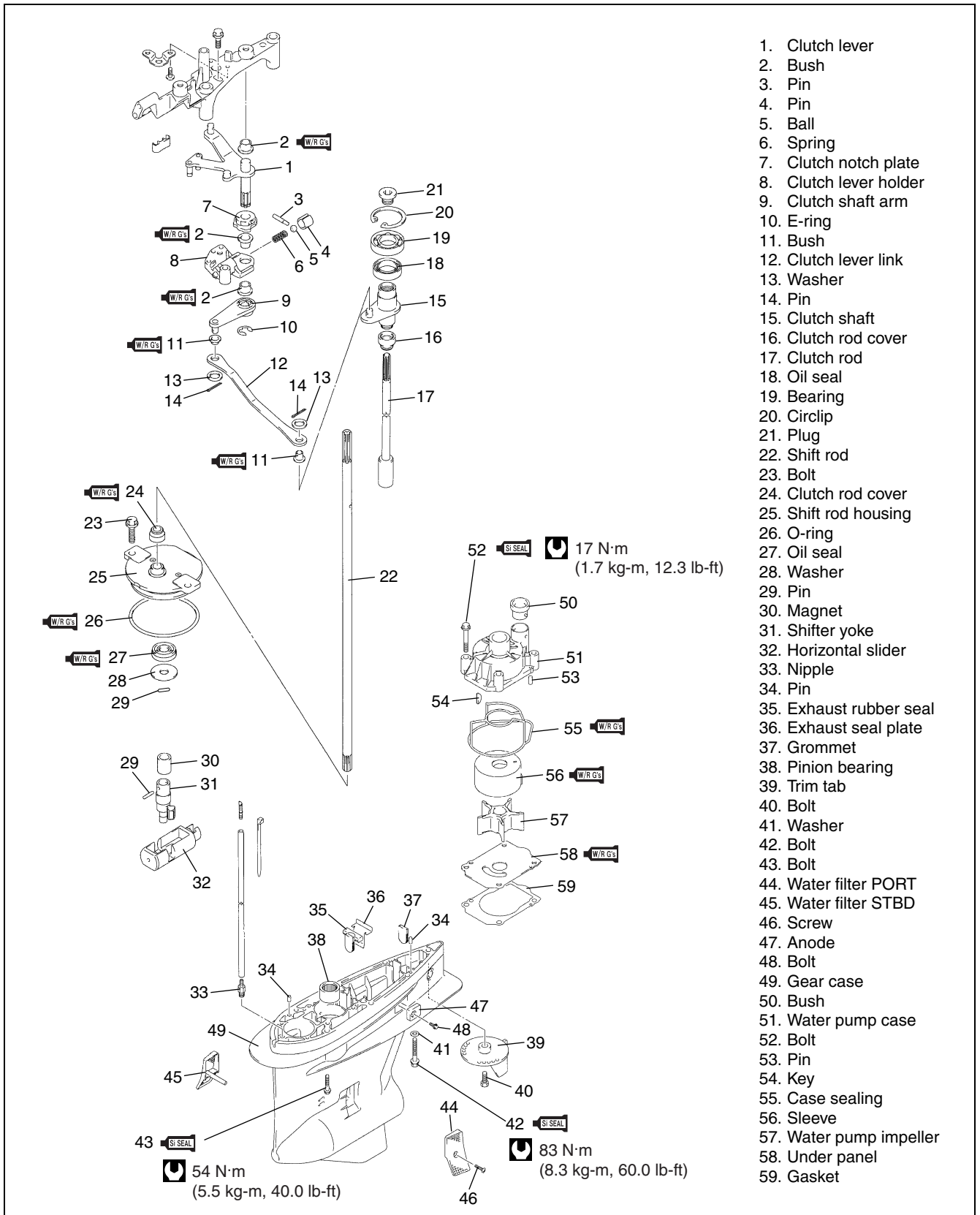

1. Clutch lever
2. Bush
3. Pin
4. Pin
5. Ball
6. Spring
7. Clutch notch plate
8. Clutch lever holder
9. Clutch shaft arm
10. E-ring
11. Bush
12. Clutch lever link
13. Washer
14. Pin
15. Clutch shaft
16. Clutch rod cover
17. Clutch rod
18. Oil seal
19. Bearing
20. Circlip
21. Plug
22. Shift rod
23. Bolt
24. Clutch rod cover
25. Shift rod housing
26. O-ring
27. Oil seal
28. Washer
29. Pin
30. Magnet
31. Shifter yoke
32. Horizontal slider
33. Nipple
34. Pin
35. Exhaust rubber seal
36. Exhaust seal plate
37. Grommet
38. Pinion bearing
39. Trim tab
40. Bolt
41. Washer
42. Bolt
43. Bolt
44. Water filter PORT
45. Water filter STBD
46. Screw
47. Anode
48. Bolt
49. Gear case
50. Bush
51. Water pump case
52. Bolt
53. Pin
54. Key
55. Case sealing
56. Sleeve
57. Water pump impeller
58. Under panel
59. Gasket

- 60. Driveshaft
- 61. Oil seal housing
- 62. O-ring
- 63. Oil seal
- 64. Nut
- 65. Spacer
- 66. Driveshaft bearing
- 67. Shim
- 68. Driveshaft collar
- 69. Pinion gear
- 70. Washer
- 71. Pinion nut
- 72. Plug
- 73. Gasket
- 74. Shift cam housing
- 75. Pin
- 76. Thrust spacer
- 77. REV gear bearing housing
- 78. Bearing
- 79. Shim
- 80. Reverse gear
- 81. Detent ball
- 82. Connector pin
- 83. Detent ball
- 84. Detent spring
- 85. Clutch dog shifter
- 86. Dog pin
- 87. Dog spring
- 88. Forward gear
- 89. Forward gear bearing

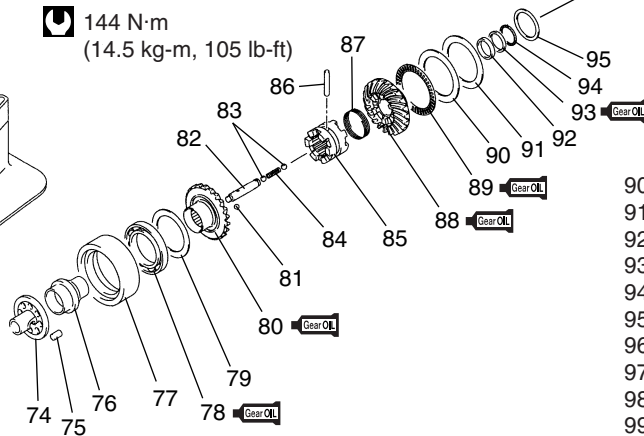
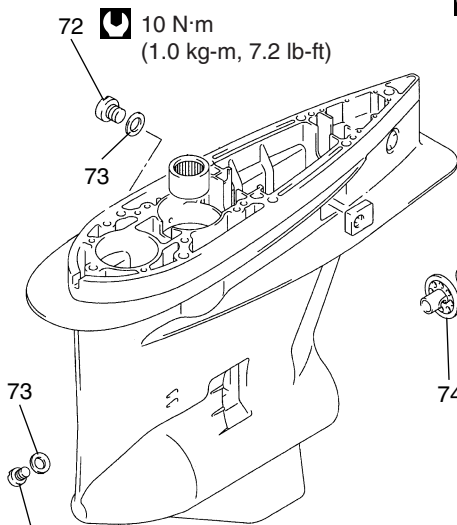
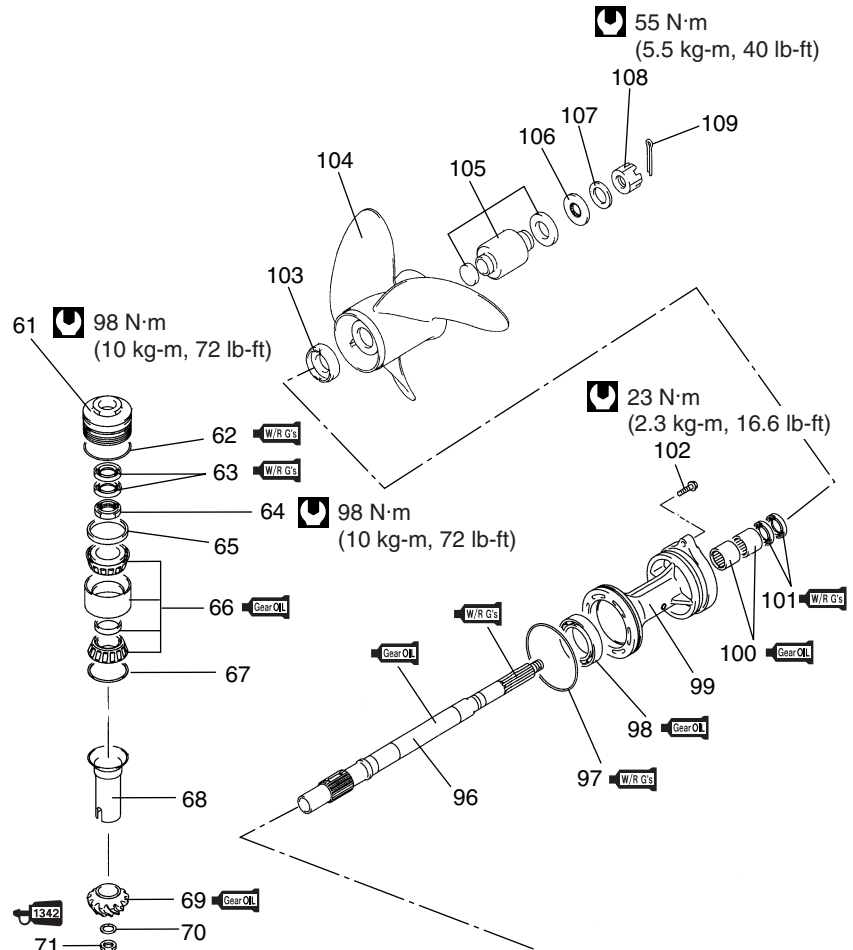
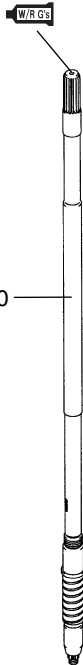

- 90. Thrust washer
- 91. Shim
- 92. Washer
- 93. Bearing
- 94. Washer
- 95. Shim
- 96. Propeller shaft
- 97. O-ring
- 98. Bearing
- 99. Propeller shaft bearing housing
- 100. Bearing
- 101. Oil seal
- 102. Bolt
- 103. Stopper
- 104. Propeller
- 105. Propeller bush set
- 106. Spacer
- 107. Washer
- 108. Nut
- 109. Pin

72 10 N·m (1.0 kg-m, 7.2 lb-ft)

CAUTION

- Make sure that all parts used in assembly are clean and lubricated.
- It is recommended that all seals, gaskets and O-rings be replaced with new on assembly.
- After assembly, check parts for tightness and smoothness of operation.
- Before final assembly, be absolutely certain that all gear contact, shim adjustments and tolerances are correct.

Failure to correctly adjust these areas will result in lower unit damage.

(See “GEARS SHIMMING AND ADJUSTMENT” section on page 10-26.)

REVERSE GEAR

Assemble the reverse gear ①, back-up shim ②, reverse gear bearing housing ③ and reverse gear thrust bearing ④, then install reverse gear/bearing housing assembly.

 99000-22540: SUZUKI OUTBOARD MOTOR GEAR OIL

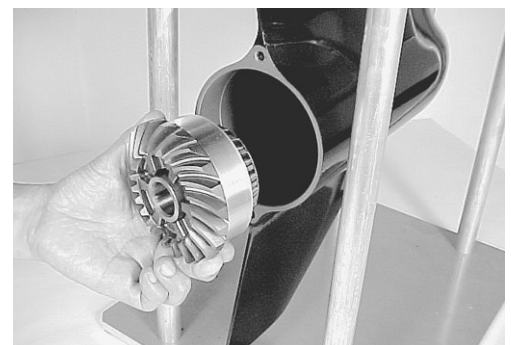
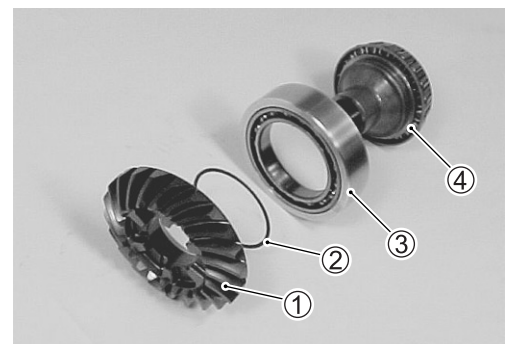

DRIVESHAFT COLLAR

Install driveshaft collar ①.

NOTE:

The tongue Ⓐ of collar must be located into groove on the gearcase.

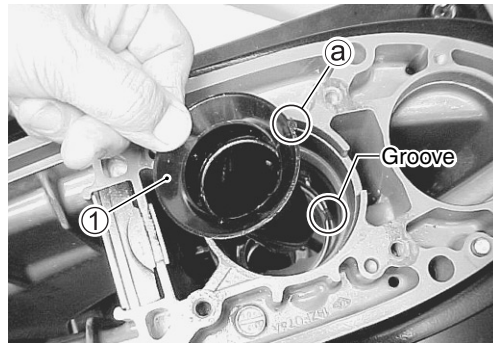
**PINION GEAR**

Place pinion gear in gearcase.

NOTE:

Before installing pinion gear, check for correct amount and position of pinion bearing rollers.

Use oil soluble grease to retain bearing rollers.

**DRIVESHAFT**

Install pinion shim ①, then lower the driveshaft assembly ② down into the gearcase until the bottom of shaft protrudes through center of pinion.

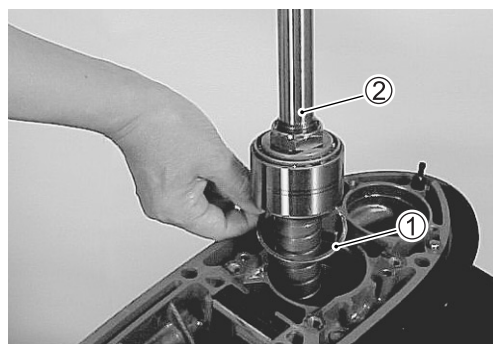
**DRIVESHAFT OIL SEAL HOUSING**

- Apply Water Resistant Grease to the driveshaft oil seal.
- Apply Water Resistant Grease to O-ring ①, then install O-ring into groove on the driveshaft oil seal housing.

WRG's 99000-25160: SUZUKI WATER RESISTANT GREASE

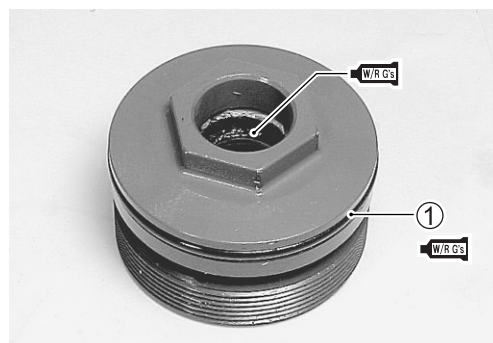

- Install driveshaft bearing spacer ②.

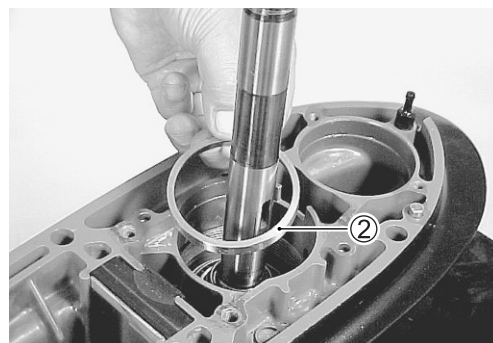

- Install driveshaft oil seal housing on gearcase, then tighten oil seal housing to specified torque.

 **Driveshaft oil seal housing: 98 N·m (10 kg·m, 72 lb·ft)**

 **09926-29310: Driveshaft housing remover**

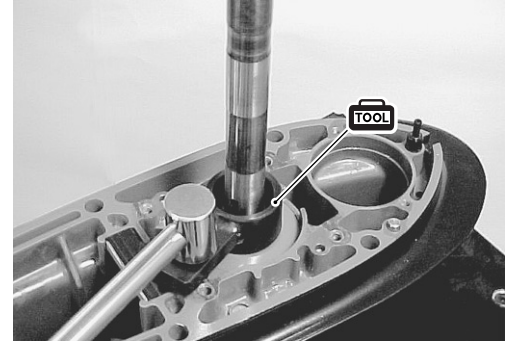

PINION NUT

- Apply THREAD LOCK 1342 to the threads of pinion nut ② before threading it onto driveshaft.

 **99000-32050: THREAD LOCK 1342**

NOTE:

It is recommended the original pinion nut be used for the purposes of shimming during repair. A new pinion nut should be used on final assembly.

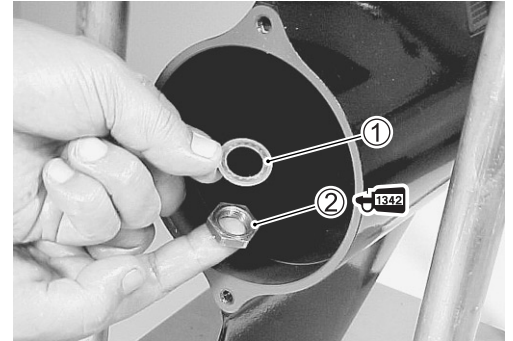

- Install washer ①, pinion nut ②, then tighten nut to specified torque.

 **Pinion nut: 144 N·m (14.5 kg·m, 105 lb·ft)**

 **09921-29410: Driveshaft holder**

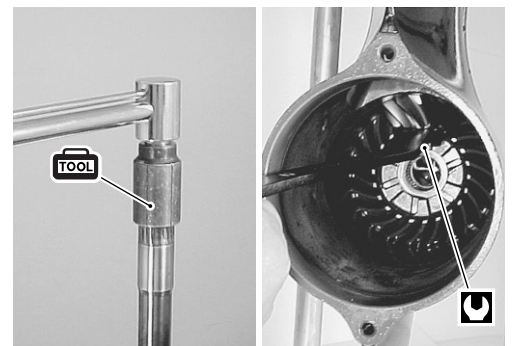

CHECKING GEAR BACKLASH

Before installing forward gear, gear backlash should be checked.

Gear backlash: Approx. 0.6 – 0.8 mm (0.023 – 0.031 in)

(See the “GEARS-SHIMMING AND ADJUSTMENT/CHECKING BACKLASH” section on page 10-27.)

 **09952-09310: Backlash indicator tool**



PROPELLER SHAFT

- Slide the clutch dog shifter ② onto the propeller shaft ①.

NOTE:

The side of the clutch dog shifter marked with the letter “F” must face towards forward gear.

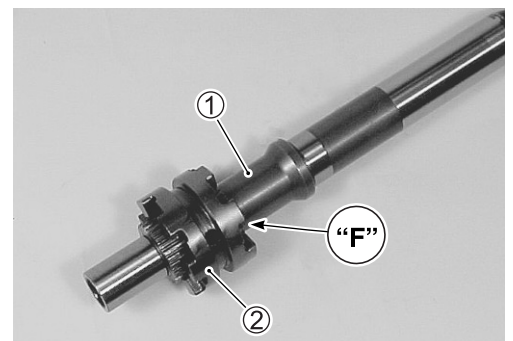

- Insert two (2) small detent balls ④, large detent ball ⑤, detent spring ⑥ and large detent ball ⑦ into connector pin ③.
Then depress detent ball ⑦ and temporarily insert stopper pin ⑧ into dog pin hole of connector pin, as shown in right figure.

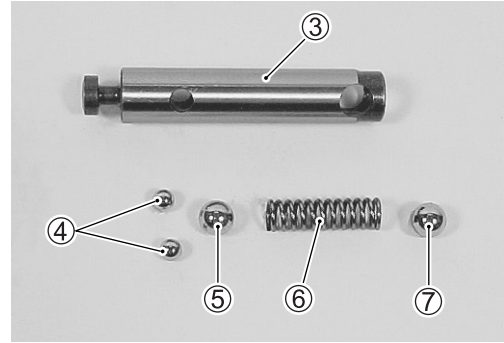

NOTE:

Temporarily insert a gearcase dowel pin ⑧ into the connector pin to prevent the detent ball from falling out.

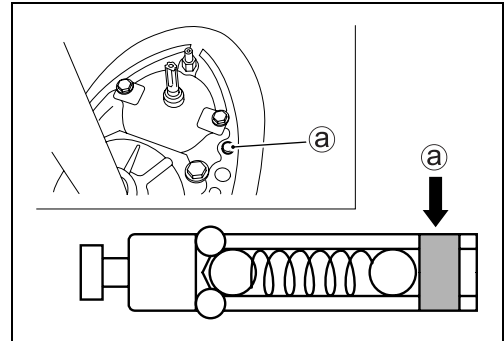

- Insert the connector pin ③ (w/detent balls) into propeller shaft ①.
- Align the holes in the shifter dog and connector pin and then slide the dog pin ⑧ through both dog and connector pin. (save the temporarily installed dowel pin pushed out as the dog pin is inserted.)
- Install the dog pin retaining spring ⑩, ensuring that it fits snugly into the groove on the dog shifter.

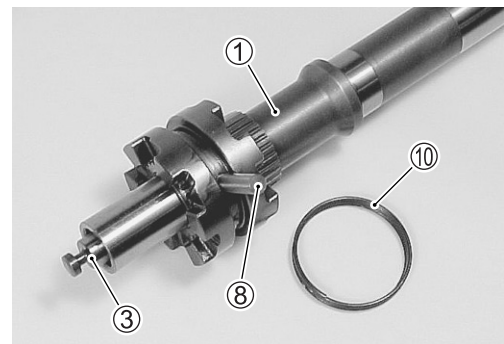

FORWARD GEAR/PROPELLER SHAFT/BEARING HOUSING

- Assemble the propeller shaft in the following sequence:

 **99000-25160 : Water Resistant Grease**

 **99000-22540 : Suzuki Outboard Motor Gear Oil**

- Apply Water Resistant Grease to O-ring ①, then install the O-ring into the groove on the propeller shaft bearing housing.



- Install shim ②, bearing washer ③, propeller shaft thrust bearing ④, propeller shaft thrust washer ⑤ into propeller shaft bearing housing ⑥.

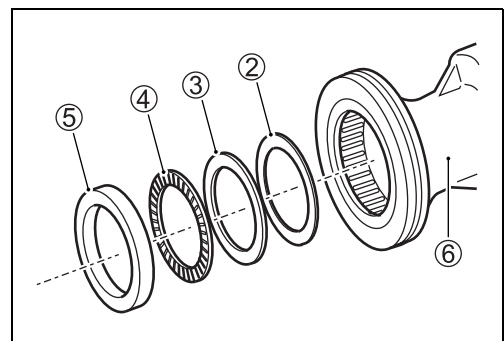

- (c) Install F-gear back-up shim ⑦, F-gear thrust washer ⑧, F-gear thrust bearing ⑨ and forward gear ⑩ to propeller shaft bearing housing.

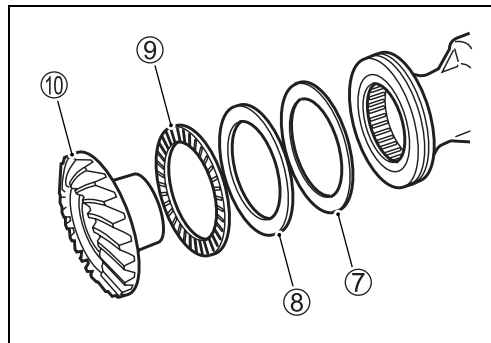

- (d) Slide propeller shaft ⑪ into forward gear and propeller shaft bearing housing.
 (e) Assemble horizontal slider ⑫ to connector pin.

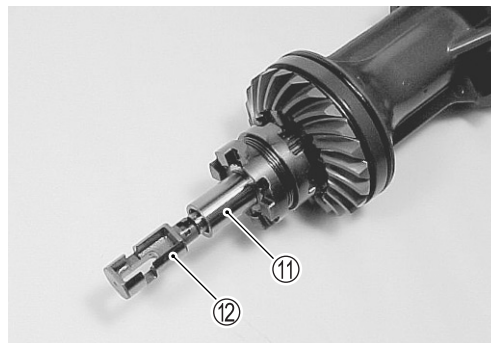

NOTE:

Before installing propeller shaft/bearing housing assembly, move shifter dog to bring horizontal slider to the neutral position.

- To hold the correct bearing position, pull propeller shaft backward and then install propeller shaft and housing assembly in the gearcase.

NOTE:

To make the bearing housing fully seated in the gearcase, tap the housing gently with plastic mallet.

- When the housing is fully seated, tighten both retaining bolts to the specified torque.

 **Bearing housing bolt: 23 N·m (2.3 kg·m, 16.6 lb-ft)**

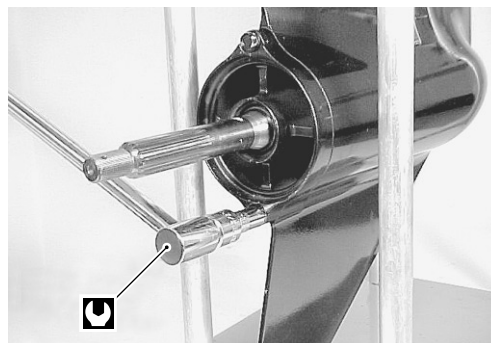
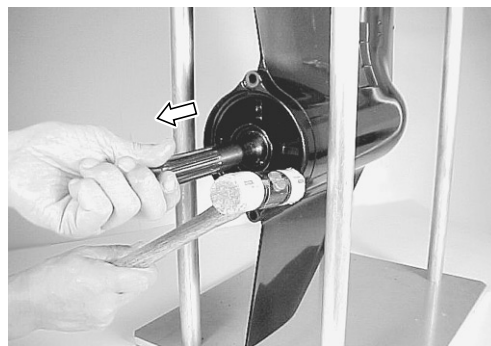

RECHECKING GEAR BACKLASH

Recheck the forward gear backlash.

Gear backlash: Approx 0.3 – 0.5 mm (0.012 – 0.020 in)

(See the “GEARS-SHIMMING AND ADJUSTMENT/CHECKING BACKLASH” section on page 10-28.)

 **09951-09310: Gear adjuster spring set**
09952-09310: Backlash indicator tool

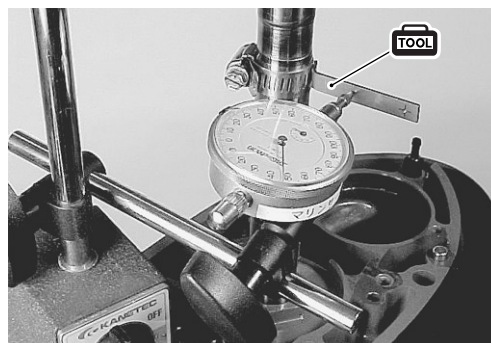

CHECKING PROPELLER SHAFT THRUST PLAY

See the "GEARS-SHIMMING AND ADJUSTMENT/CHECKING PROPELLER SHAFT THRUST PLAY" section on page 10-30.

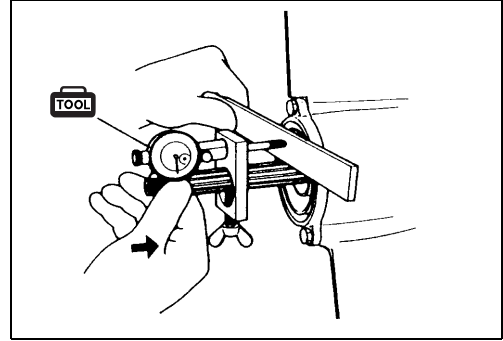

SHIFT ROD GUIDE HOUSING

- Using an oil seal installer, drive the oil seal ① into the shift rod guide housing ②.
The lipped portion of oil seal must face towards the driveshaft housing.

WRG's 99000-25160: SUZUKI WATER RESISTANT GREASE

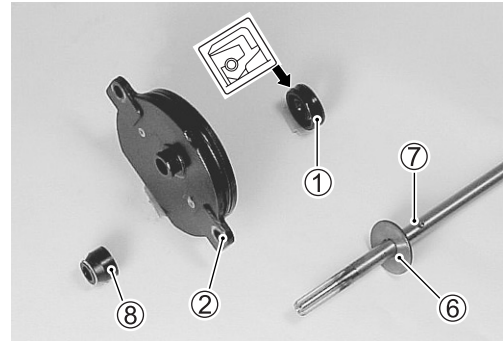

- Attach shifter yoke ④ to shift rod ③, then insert pin ⑤.
- Install pin ⑦ and washer ⑥ to shift rod, then slide shift rod guide housing onto shift rod.
- Install dust seal ⑧ to shift rod guide housing.

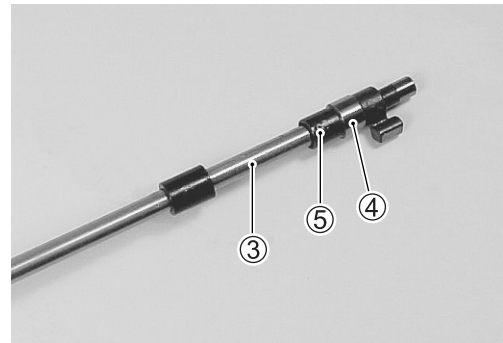

NOTE:

Be sure the horizontal slider is in the neutral position before installing the shift unit (shift rod guide housing assembly.).

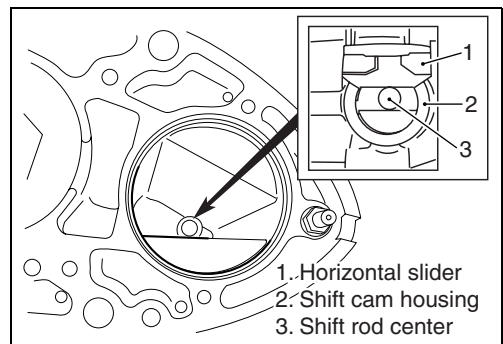

- Apply Water Resistant Grease to the shift rod guide housing O-ring.

WRG's 99000-25160: SUZUKI WATER RESISTANT GREASE

NOTE:

Before installing shift rod guide housing assembly, bring shifter yoke to neutral position by turning shift rod right or left.

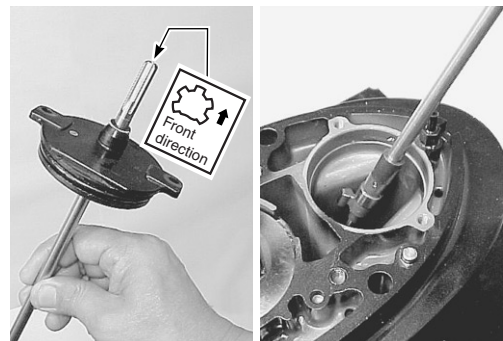

- Install shift rod guide housing assembly by aligning shifter yoke with groove in horizontal slider, then tighten two (2) housing bolts securely.
- Turn shift rod from Neutral position to Forward and Reverse position to check proper gear engagement.

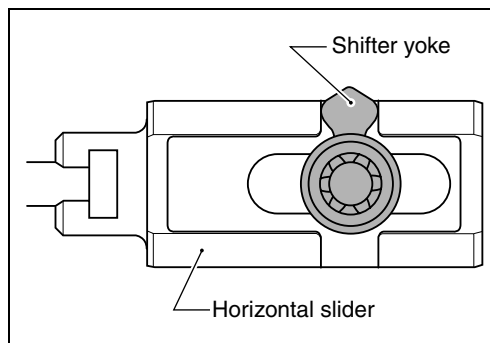
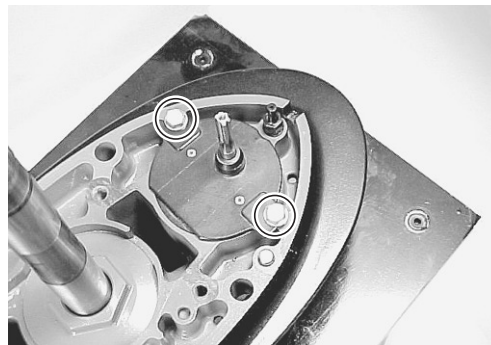

LEAKAGE CHECK

Check for leakage of oil seal and O-ring when applying specified pressure inside of the gearcase.

TOOL 09950-69511: Oil leakage tester
09952-99310: Air pump

Procedure

1. Install the test tool into the oil drain hole.
2. Connect the air pump to the tester.
3. Rotate driveshaft and propeller shaft clockwise several times and then apply specified pressure for the test.

NOTE:

Apply low initial pressure of 20 – 40 kPa, (0.2 – 0.4 kg/cm², 2.8 – 5.7 psi) first, then apply specified pressure.

Leakage test pressure: 100 kPa (1.0 kg/cm², 14.2 psi)

CAUTION

Do not exceed pressure of 110 kPa (1.1kg/cm², 15.6 psi) or damage to oil seals will result.

4. Once stabilized, pressure should remain steady for at least 5 min.
If pressure does not fall, sealing performance is correct.

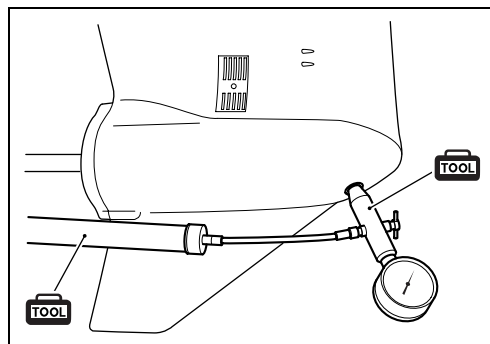

WATER PUMP (Impeller & case)

- Place the dowel pins ①, under panel gasket ② and under panel ③ into position.
- Insert the key ④ in the driveshaft and slide the impeller ⑤ onto driveshaft, ensuring that key and keyway are aligned.

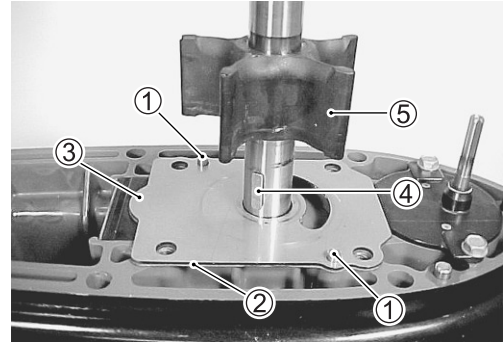

- Place the seal ring ⑦ into groove of the pump case ⑥, then install inner sleeve ⑧ to pump case.

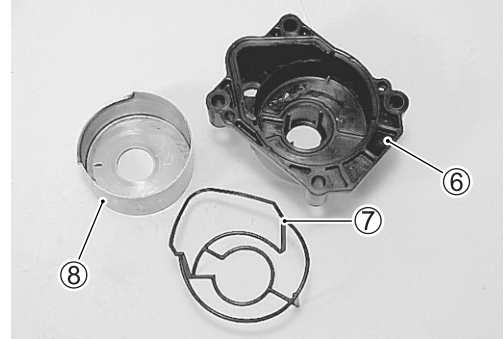

CAUTION

**Do not re-use seal ring once removed.
Always use new ring.**

NOTE:

Before installing pump inner sleeve, apply water resistant grease lightly between inner sleeve and pump case mating surfaces.

 **99000-25160: SUZUKI WATER RESISTANT GREASE**

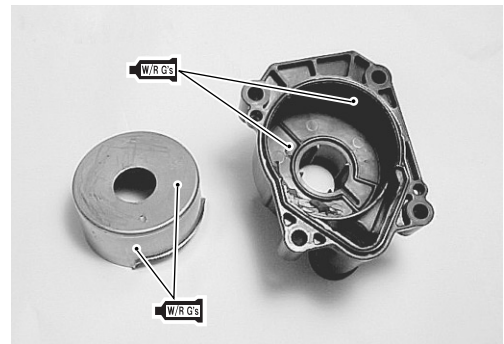

NOTE:

Before installing water pump case assembly, apply Water Resistant Grease lightly on pump case inner sleeve and under panel for initial lubrication.

 **99000-25160: SUZUKI WATER RESISTANT GREASE**

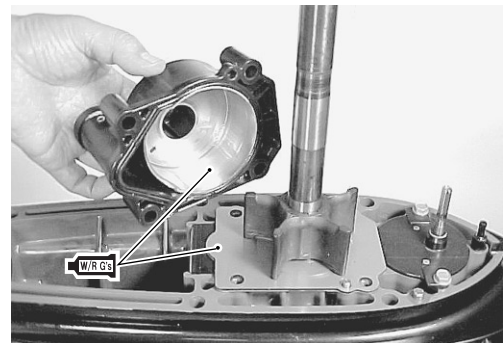

- Install the pump case assembly ⑨ while rotating driveshaft clockwise to flex the impeller vanes in the correct direction.
- Securely tighten the four (4) pump case bolts ⑩ to the specified torque.

 **Pump case bolt: 17 N·m (1.7 kg·m, 12.5 lb·ft)**

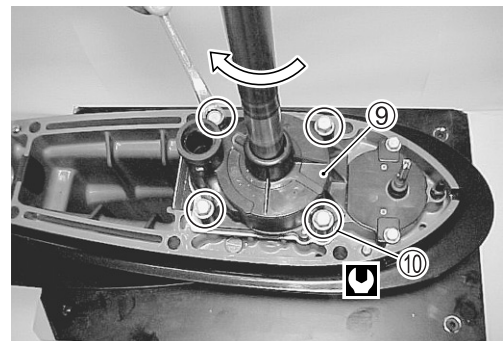

PROPELLER INSTALLATION

Install propeller stopper ① onto propeller shaft, then slide on the propeller ②.

Fit spacer ③, washer ④ and nut ⑤, then tighten nut to specified torque.

Push cotter pin ⑥ through nut and shaft, then bend to secure.

 **99000-25160: SUZUKI WATER RESISTANT GREASE**

 **Propeller nut: 55 N·m (5.5 kg·m, 40.0 lb·ft)**

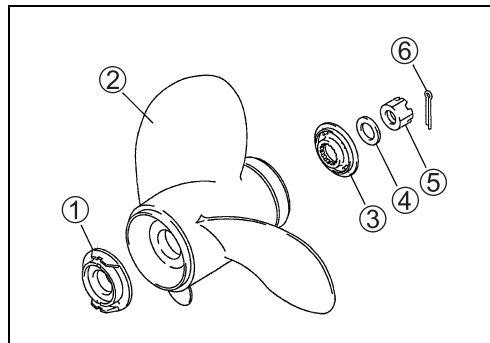

LOWER UNIT INSTALLATION

- Apply Water Resistant Grease to clutch rod splines, then install clutch rod ① by aligning clutch rod splines with splines in clutch shaft.

 **99000-25160: SUZUKI WATER RESISTANT GREASE**



- Ensure that shift rod ② is at neutral position.

NOTE:

Before installing lower unit assembly, bring shift to neutral position by turning shift rod right or left.

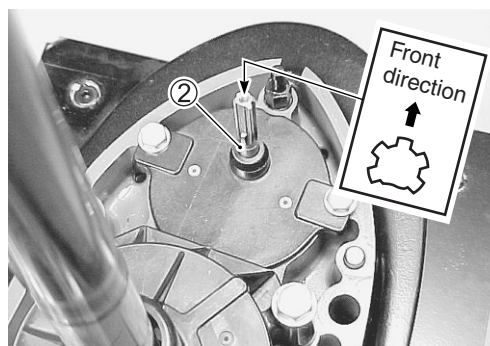

- Insert two (2) dowel pins ③.
- Apply Water Resistant Grease to driveshaft and shift rod splines.
- Apply a light coating of SUZUKI SILICONE SEAL to mating surfaces of gearcase and driveshaft housing.

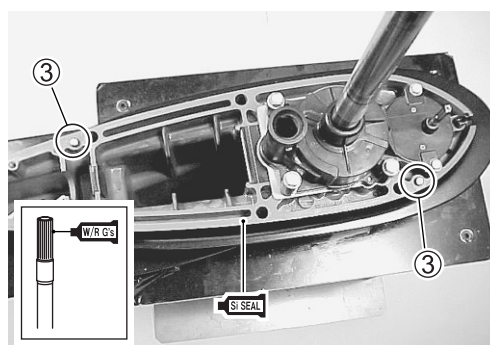

- Install spacer ④ to water tube.

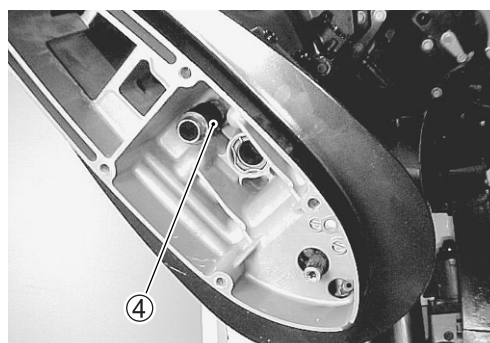

- Set the clutch control lever ⑤ at Neutral position, then slide the lower unit ⑥ into place, ensuring that the top of driveshaft engages properly with driven gear shaft and that water tube locates in water pump case outlet.

NOTE:

In order for shift rod and clutch rod splines to be aligned correctly, clutch rod may need to be turned slightly right or left.

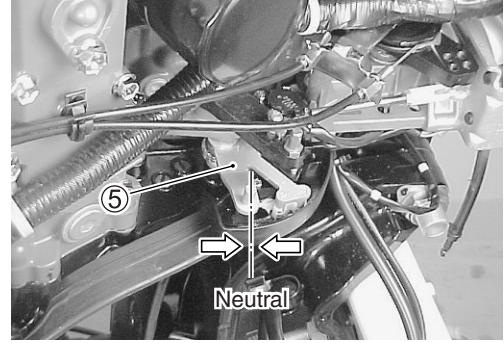

- Apply SUZUKI SILICONE SEAL to seven (7) gearcase bolts ⑦ and tighten them to specified torque.

Gearcase bolt: 10 mm 54 N·m (5.5 kg-m, 40.0 lb-ft)
12 mm 83 N·m (8.3 kg-m, 60.0 lb-ft)

W/R G's 99000-25160: SUZUKI WATER RESISTANT GREASE

SI SEAL 99000-31120: SUZUKI SILICONE SEAL

- Shift the clutch control lever to Forward and Reverse position from Neutral position to check proper gear engagement.

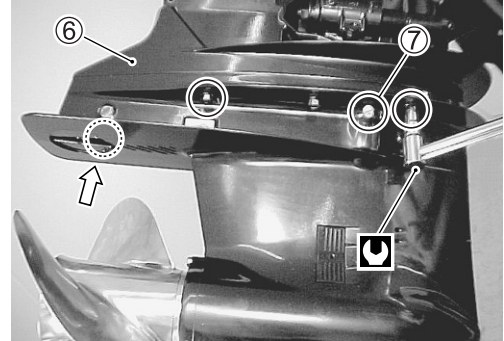

GEAR OIL

Fill the gearcase with specified gear oil for initial testing and recheck the level after 10 minutes. Top up if necessary.

(See “PERIODIC MAINTENANCE/GEAR OIL” section on page 2-6.)

Gear Oil 99000-22540: SUZUKI OUTBOARD MOTOR GEAR OIL

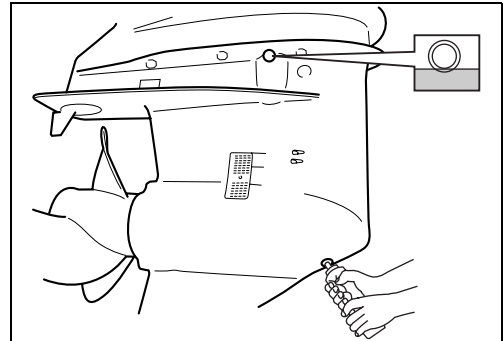

TRIM TAB

The trim tab counteracts or minimizes propeller torque “pull” felt through the steering system.

If the steering is pulled to starboard or port side, adjust trim tab with following procedure:

Adjusting

1. Loosen the bolt of trim tab.
2. Change direction of trim tab.
 - To compensate for a veer to starboard, set trailing edge of tab to the right (as viewed from behind).
 - To compensate for a veer to port, set trailing edge of tab to the left.
3. Tighten the bolt of trim tab.
4. Test ride the boat and repeat the procedure 1 – 3 to set the trim tab in the best position.

With a properly adjusted trim tab, steering should be neutral and there should be no tendency for the steering to be pulled to either port or starboard.

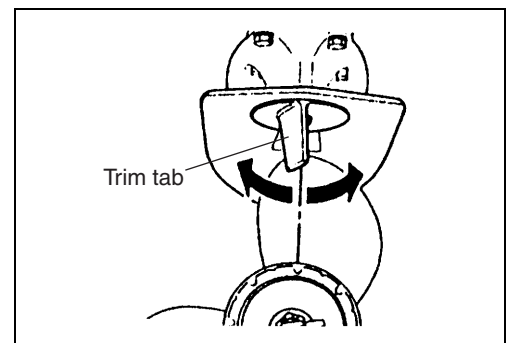
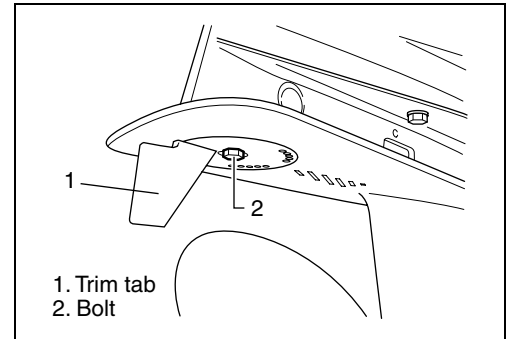

LOWER UNIT GEARS- SHIMMING AND ADJUSTMENT

(Counter rotation model)

If lower unit has been rebuilt or has had components replaced, shimming for correct gear contact and backlash will have to be adjusted to ensure smooth, reliable operation of gears.

Shim/Washer & Mounting position

	Numerical index/item	Available thickness (mm)	Design specification Thickness (mm)
①	Pinion gear back up shim	0.45, 0.50, 0.55, 0.60, 0.65, 0.70, 0.75, 0.80, 0.85, 0.90	1.0
②	Forward gear back up shim	0.50, 0.60, 0.65, 0.70, 0.75, 0.80, 0.85, 0.90, 0.95, 1.00	0.8
③	Propeller shaft thrust shim	0.60, 0.70, 0.80, 0.90, 0.95, 1.00, 1.05, 1.10, 1.15	1.0
④	Reverse gear back up shim	0.45, 0.50, 0.55, 0.60, 0.65, 0.70, 0.75, 0.80, 0.85, 0.90	1.0

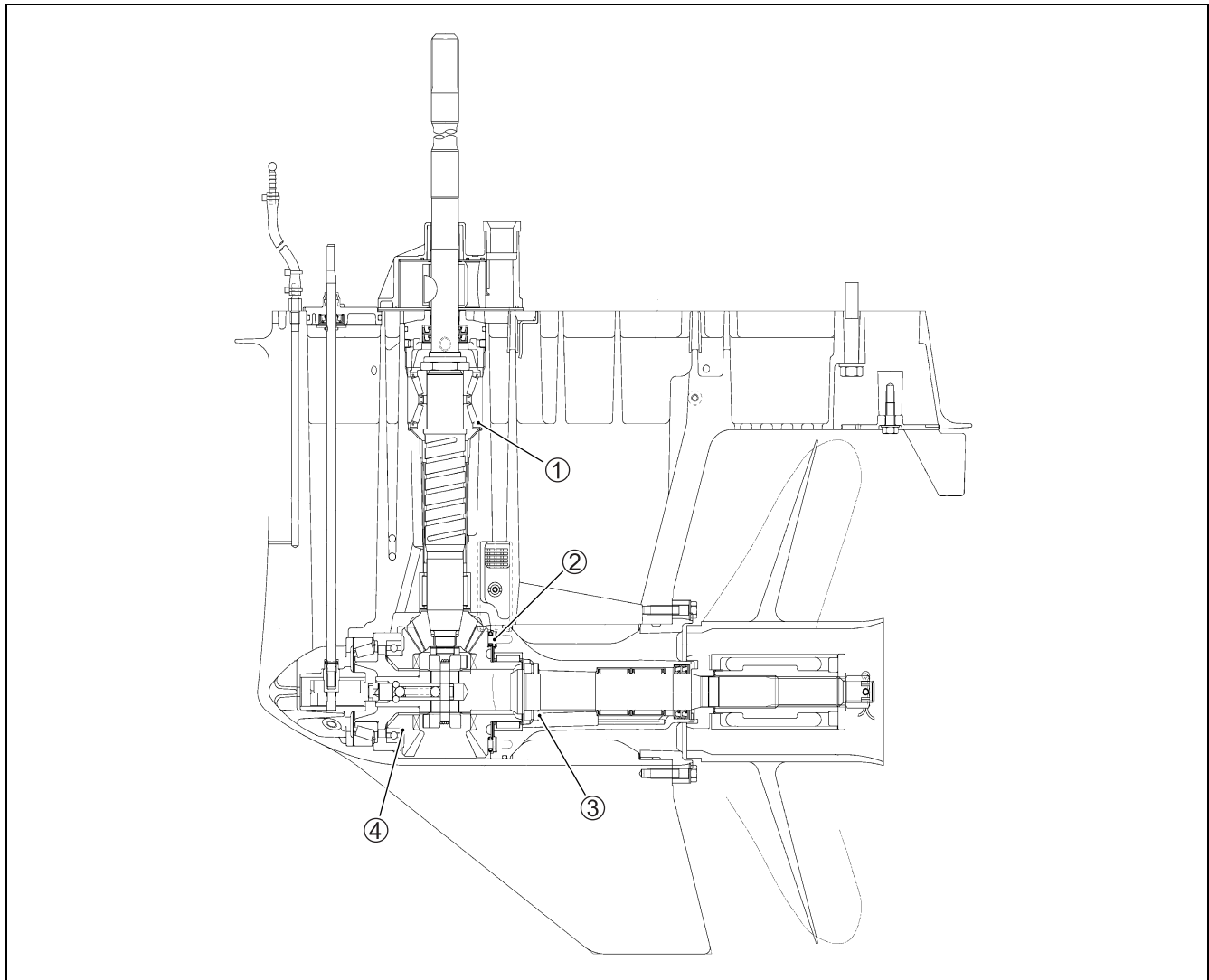

REVERSE GEAR/PINION GEAR

Follow the procedure below to adjust reverse gear/pinion gear.

STEP TO PRIOR TO ADJUSTMENT

1. Install standard pinion gear back-up shim thickness modified according to \pm design specification mark on gear.

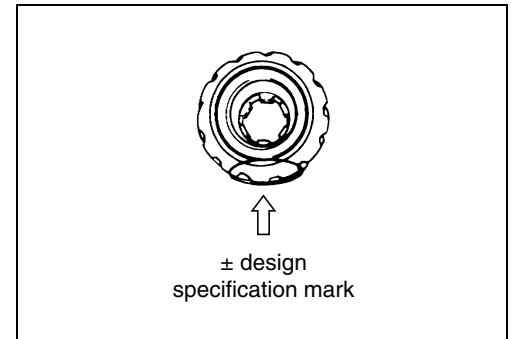

2. Correctly assemble driveshaft oil seal housing, driveshaft, reverse gear, pinion gear and related components. (See page 10-15 to 10-17.)

Do not install forward gear at this time.

3. Tighten pinion nut to specified torque.

 **Pinion nut: 144 N·m (14.4 kg·m, 104 lb·ft)**



ADJUSTING GEAR BACKLASH

- (a) Assemble special tool to driveshaft as shown in figure.

 **09900-20606: Dial gauge**
09900-20701: Magnetic stand
09952-09310: Backlash indicator tool

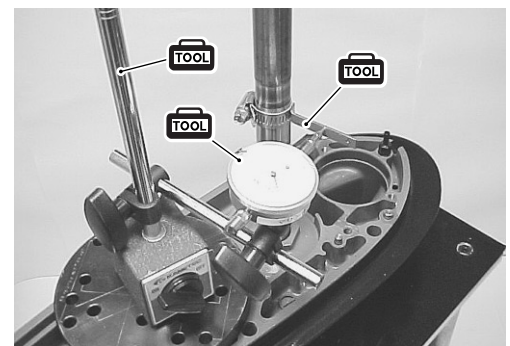

- (b) Push reverse gear inward and hold it by hand, Align dial gauge pointer at 90 ° to the mark on the backlash indicator tool and read backlash on dial gauge by lightly moving drive-shaft clockwise and counterclockwise by hand.

Gear backlash: Approx. 0.6 – 0.8 mm (0.024 – 0.031 in)

- If the backlash measured is larger than the specification, add the amount over the specification to the temporary use reverse gear back-up shim and install this shim as the final shim.
- If the backlash measured is smaller than the specification, subtract the amount less than the specification from the temporary use reverse gear back-up shim and install this shim as the final shim.

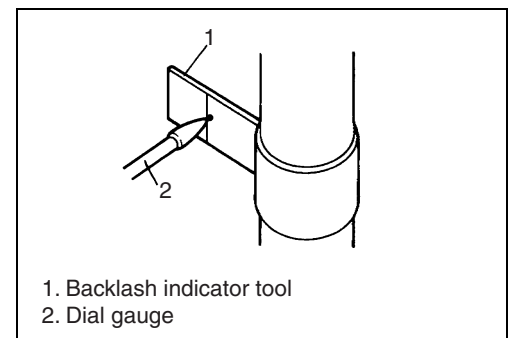

FORWARD GEAR SHIM

After adjusting reverse gear backlash, follow the procedure below to adjust forward gear.

Adjusting gear backlash

1. Correctly assemble driveshaft oil seal housing, driveshaft, reverse gear, pinion gear and related components. (See page 10-15 to 10-17.)
2. Tighten pinion nut to specified torque.

Pinion nut: 144 N-m (14.4 kg-m, 104 lb-ft)

3. Correctly assemble forward gear, forward gear bearing, propeller shaft, propeller shaft thrust bearing, propeller shaft bearing housing and related components.

When assemble the forward gear and propeller shaft housing assembly, place the special tool between clutch dog shifter and forward gear as shown in the illustration.

NOTE:

Before installing special tool, move shifter dog to reverse position.

09951-09310: Gear adjuster spring set

4. Install forward gear and propeller shaft housing assembly into gearcase, then tighten both bearing housing retaining bolts to specified torque.

5. Assemble special tool to driveshaft as shown in figure.

09900-20606: Dial gauge

09900-20701: Magnetic stand

09952-09310: Backlash indicator tool

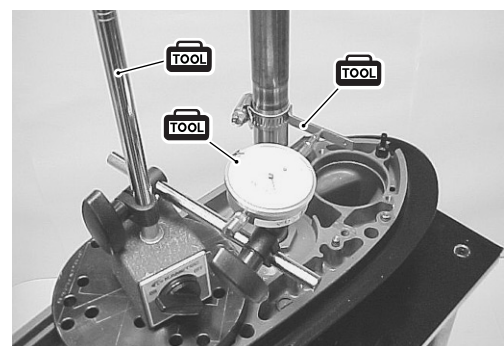
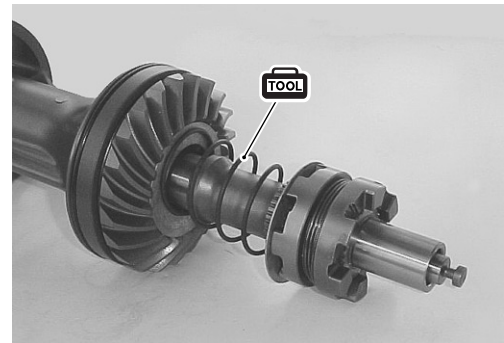
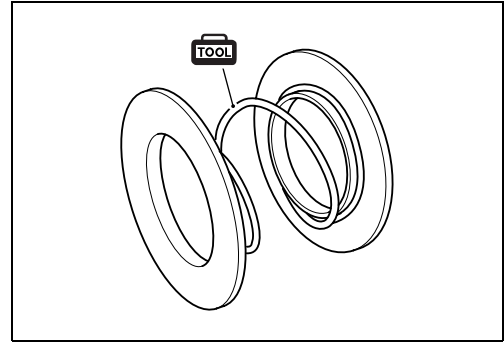

- Align dial gauge pointer at 90 ° to the mark on the backlash indicator tool and read backlash on dial gauge by lightly moving driveshaft clockwise and counterclockwise by hand.

Gear backlash: Approx. 0.3 – 0.5 mm (0.012 – 0.020 in)

- If the backlash measured is larger than the specification, add the amount over the specification to the temporary use forward gear back-up shim and install this shim.
- If the backlash measured is smaller than the specification, subtract the amount less than the specification from the temporary use forward gear back-up shim and install this shim.

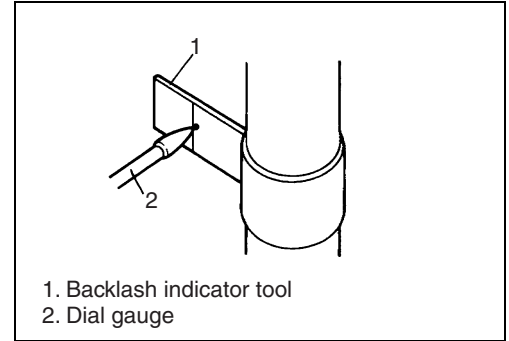

Checking and adjusting tooth contact pattern (Pinion and Forward gear)

Check tooth contact pattern using the following procedure:

- To assess tooth contact, apply a light coat of Prussian Blue on the convex surface of forward gear.

NOTE:

While assessing tooth contact, remove the special tool, gear adjust spring set (09951-09310).

- Install forward gear and propeller shaft housing assembly into gearcase, then tighten both bearing housing retaining bolts to specified torque.
- Using driveshaft holder tool, rotate the driveshaft 5 – 6 times.

 **09921-29410 : Driveshaft holder**

- Carefully pull out propeller shaft and housing to check tooth contact pattern.

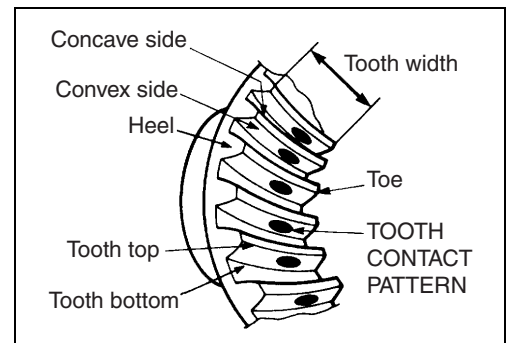

Optimum tooth contact

The optimum tooth contact is shown at right.

A shim adjustment may be necessary to obtain this contact pattern.

CAUTION

Gear backlash should be checked when increasing or decreasing shim thickness to adjust tooth contact.

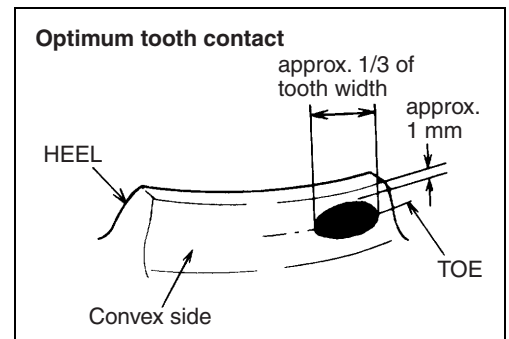

Example (1)

Incorrect topside toe contact:

Correction measures:

- Decrease thickness of forward gear shim.
- Slightly decrease pinion gear shim thickness.

CAUTION

Do not set tooth contact in this position (top side toe contact). Damage and chipping of forward and pinion gear may result.

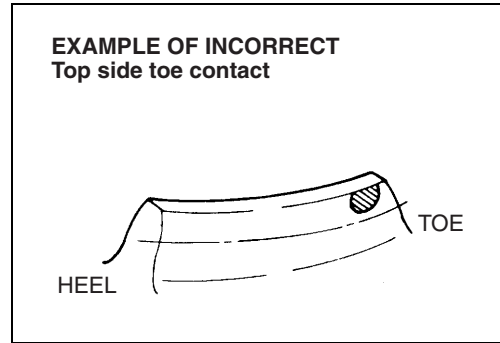
**Example (2)**

Incorrect bottom side toe contact:

Correction measures:

- Increase thickness of forward gear shim.
- Slightly increase pinion gear shim thickness.

CAUTION

Do not set tooth contact in this position (bottom side toe contact). Chipping of pinion gear may result.

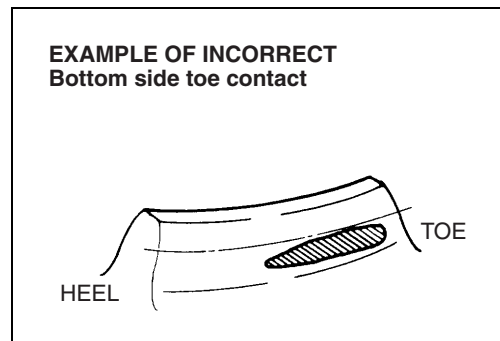

CHECKING PROPELLER SHAFT THRUST PLAY

After adjusting all gear positions, measure the propeller shaft thrust play. If not within the following specification, a shim adjustment is required.

Propeller shaft thrust play : 0.2 – 0.4 mm (0.008 – 0.016 in)

NOTE:

Use only the propeller shaft thrust shim to adjust thrust play.

Measurement step :

1. Assemble gear adjusting gauge to the propeller shaft.

TOOL 09951-09511: Gear adjusting gauge

2. Push propeller shaft inward.
3. Hold shaft in and set dial gauge pointer to zero.
4. Slowly pull shaft outward and read the maximum thrust play on the dial gauge.
 - If measurement is more than specification, increase propeller shaft thrust shim thickness.
 - If measurement is less than specification, reduce propeller shaft thrust shim thickness.

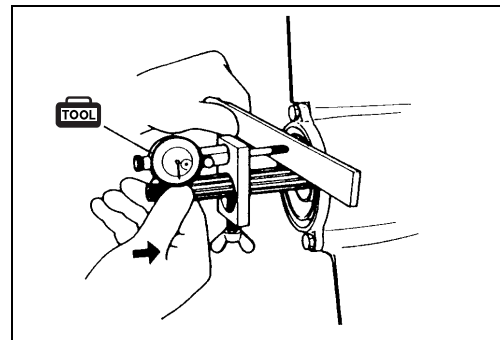

WIRE/HOSE ROUTING

CONTENTS

WIRING DIAGRAM	11- 2
DF200/DF225	11- 2
DF250	11- 3
WIRE ROUTING	11- 4
FUEL/WATER HOSE ROUTING	11-10

WIRING DIAGRAM

DF200/DF225

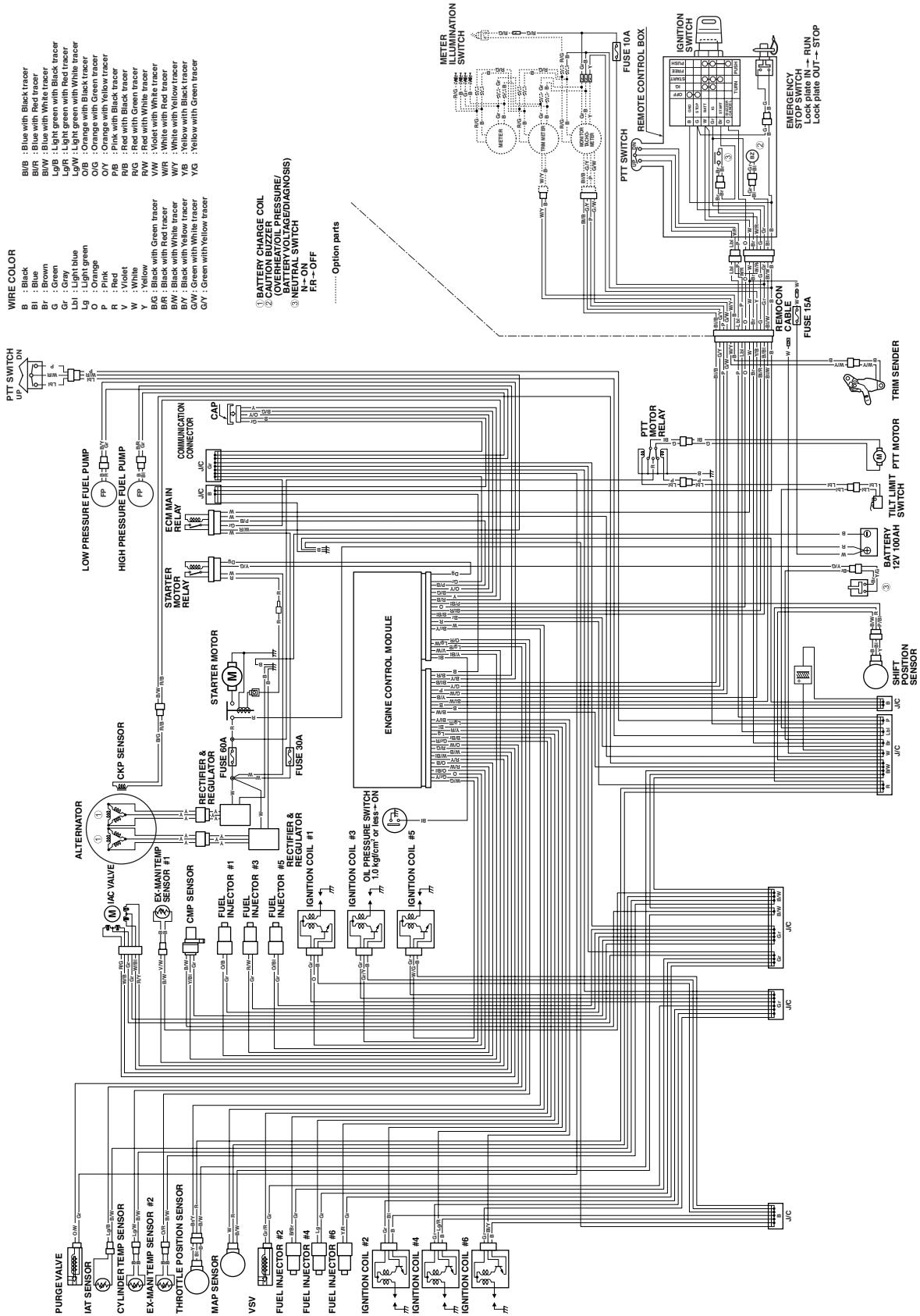

DF250

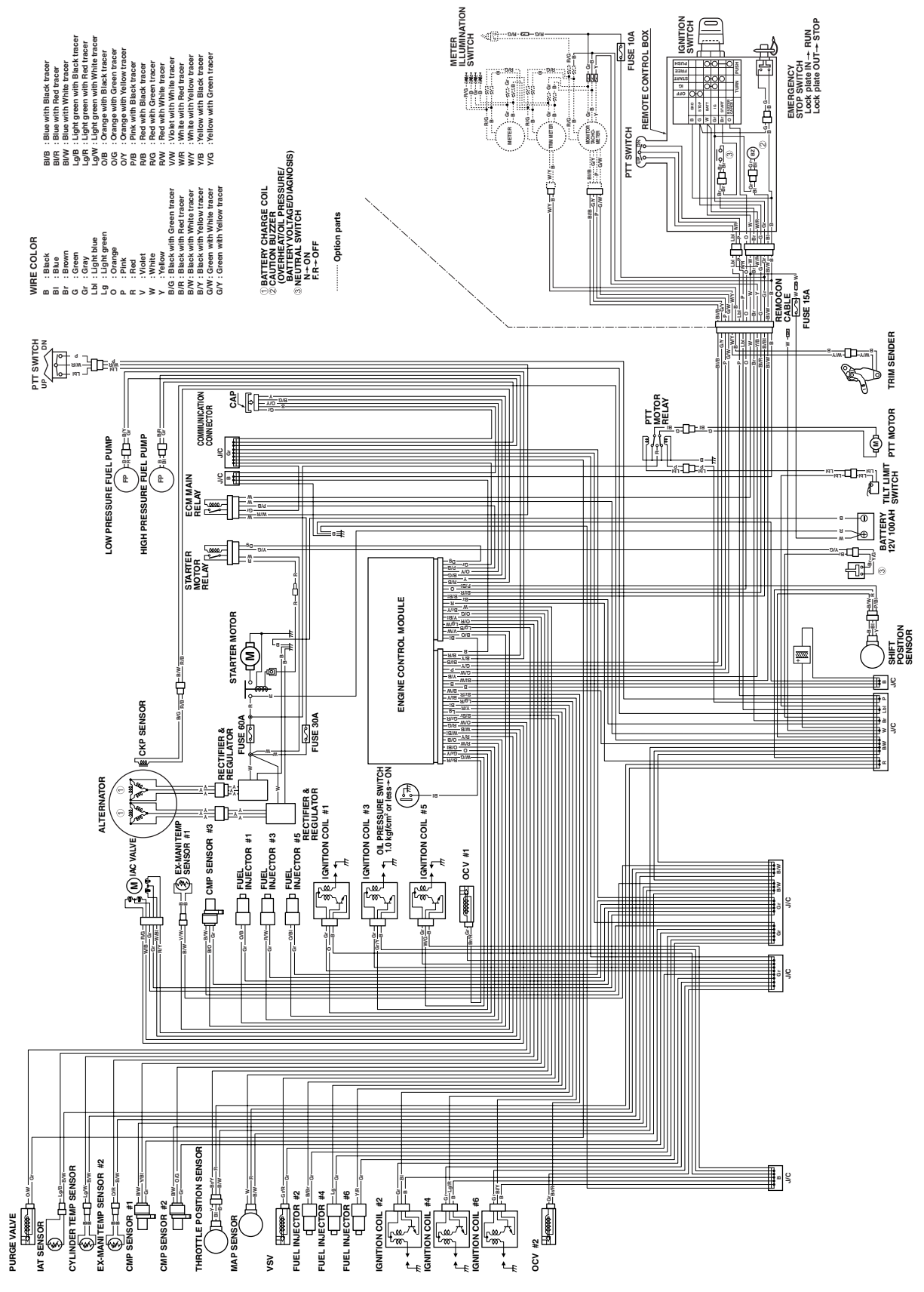

WIRE COLOR

- Black
- Bl : Blue with Black tracer
- Bl/W : Blue with White tracer
- Br : Brown
- G : Green
- Gr : Gray
- Lg : Light blue
- Lg/W : Light green with White tracer
- O : Orange
- O/W : Orange with White tracer
- O/Y : Orange with Yellow tracer
- P : Pink
- R : Red
- R/W : Red with White tracer
- W : White
- Y : Yellow
- B/G : Black with Green tracer
- B/R : Black with Red tracer
- B/W : Black with White tracer
- Gr/W : Green with White tracer
- G/W : Green with Yellow tracer
- Y/G : Yellow with Green tracer

- ① BATTERY CHARGE COIL
- ② CAUTION BUZZER (OVERHEAT/OIL PRESSURE/ BATTERY VOLTAGE/DIAGNOSIS)
- ③ BATTERY VOLTAGE/DIAGNOSIS SWITCH
- N-ON
- FR-OFF

..... Option parts

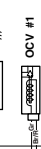
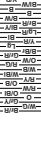
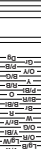
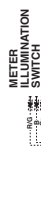

WIRE ROUTING

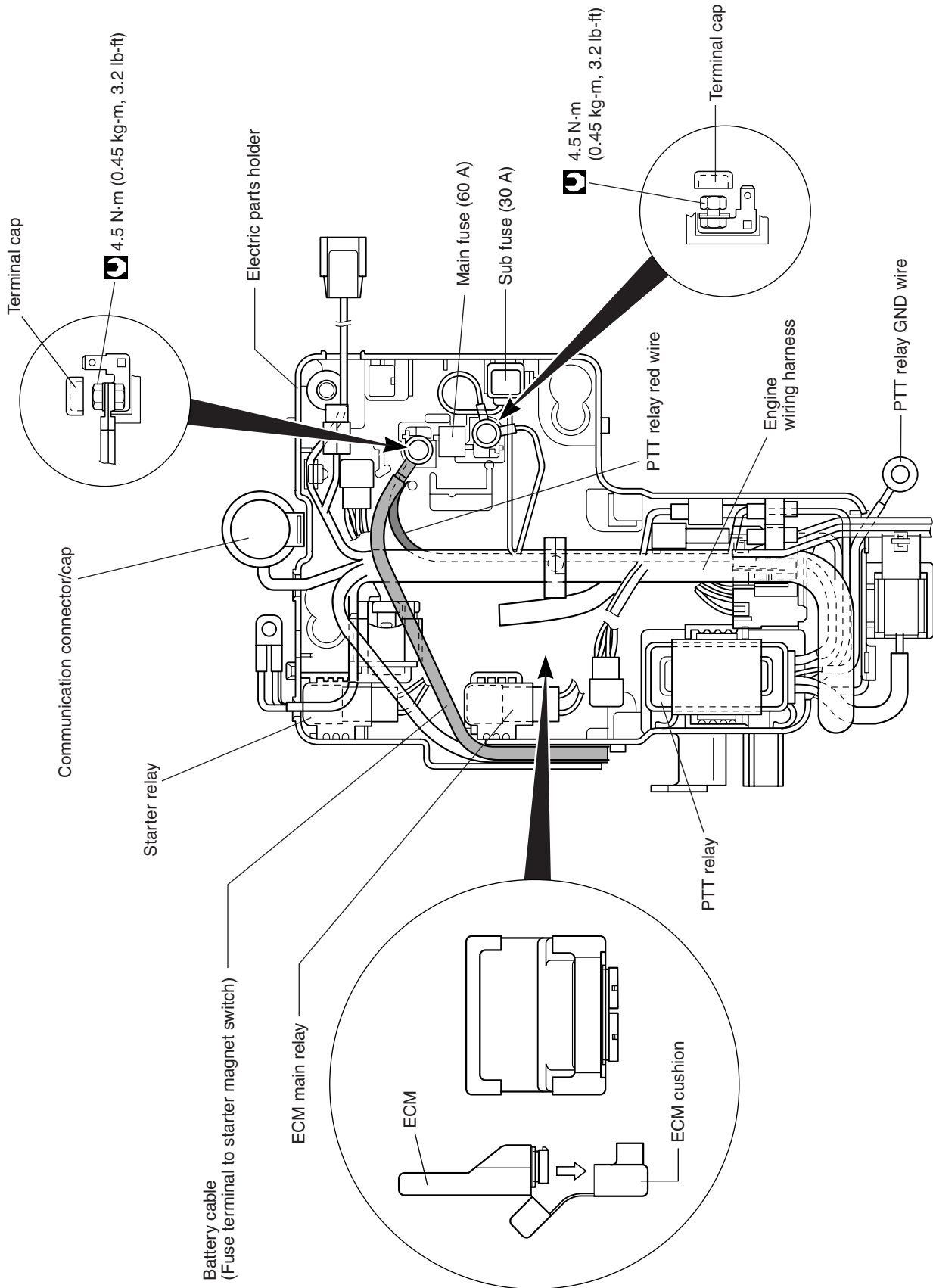

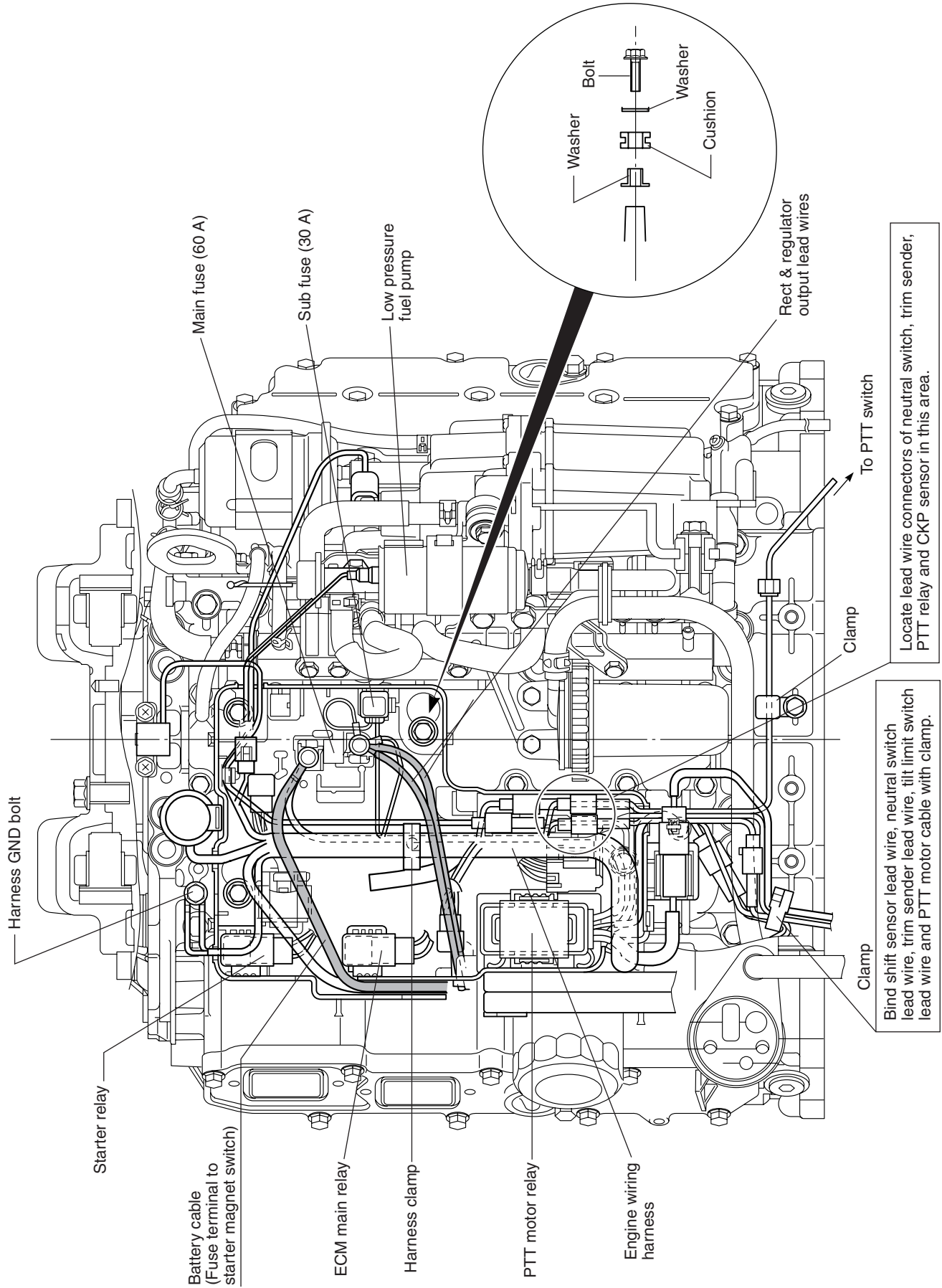

Harness GND bolt

Starter relay

Battery cable
(Fuse terminal to
starter magnet switch)

ECM main relay

Harness clamp

PTT motor relay

Engine wiring
harness

Main fuse (60 A)

Sub fuse (30 A)

Low pressure
fuel pump

Rect & regulator
output lead wires

Clamp

To PTT switch

Clamp

Bind shift sensor lead wire, neutral switch
lead wire, trim sender lead wire, tilt limit switch
lead wire and PTT motor cable with clamp.

Locate lead wire connectors of neutral switch, trim sender,
PTT relay and CKP sensor in this area.

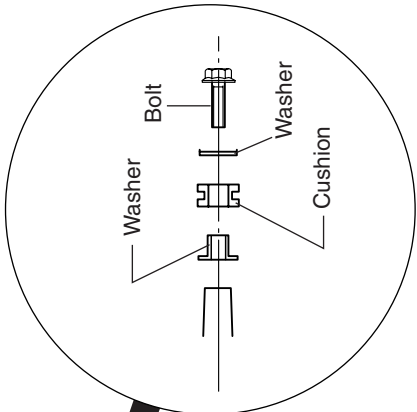

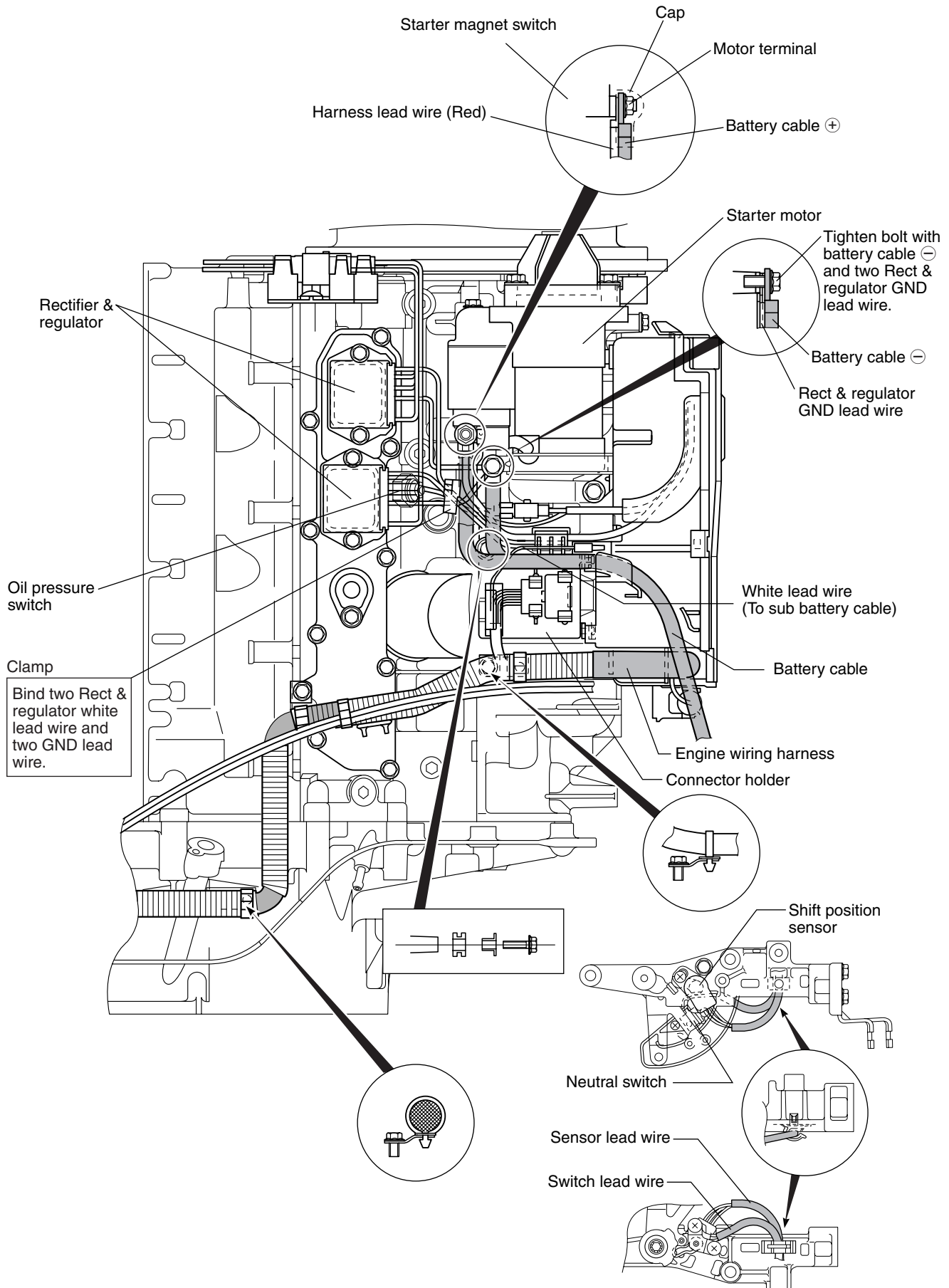

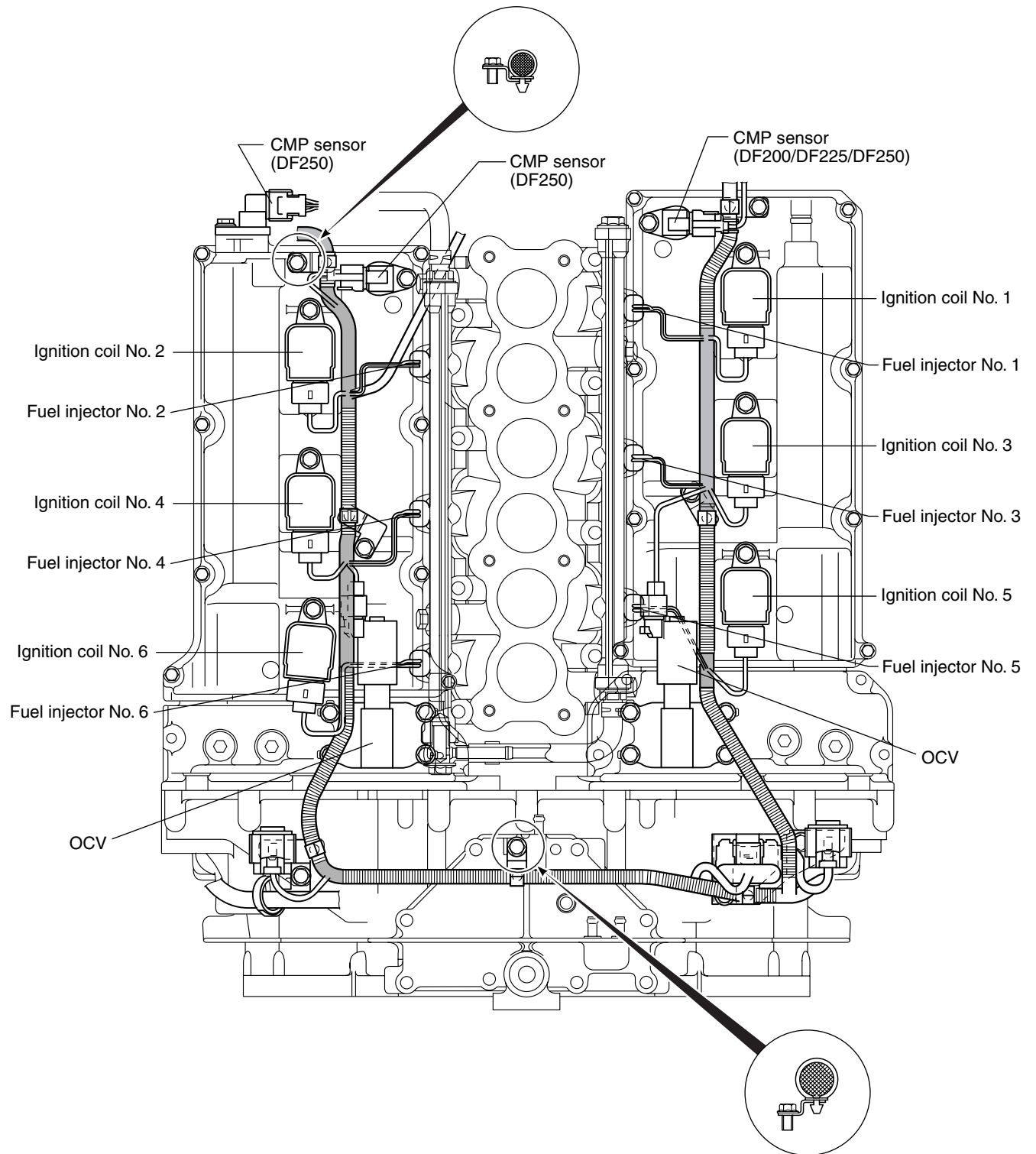

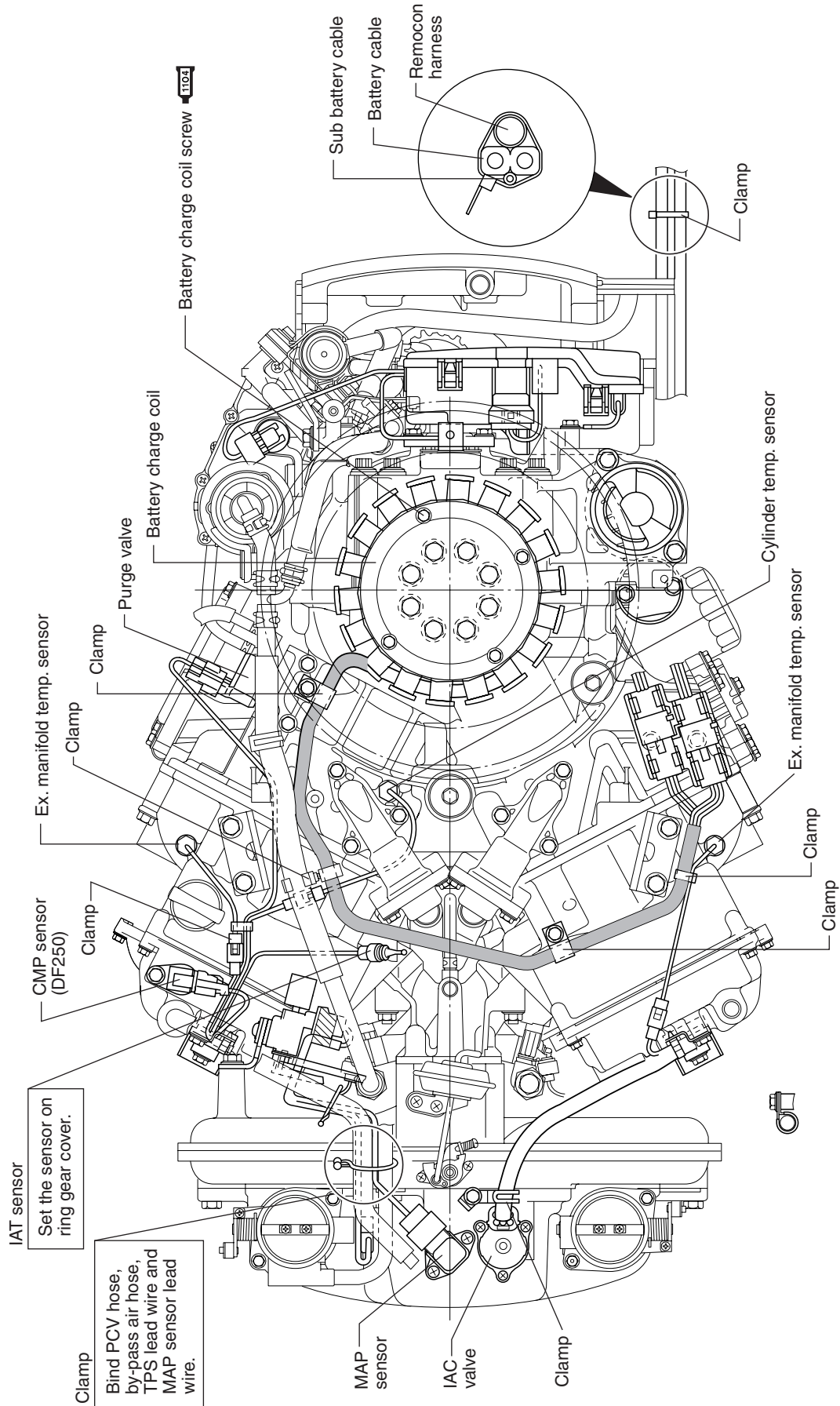

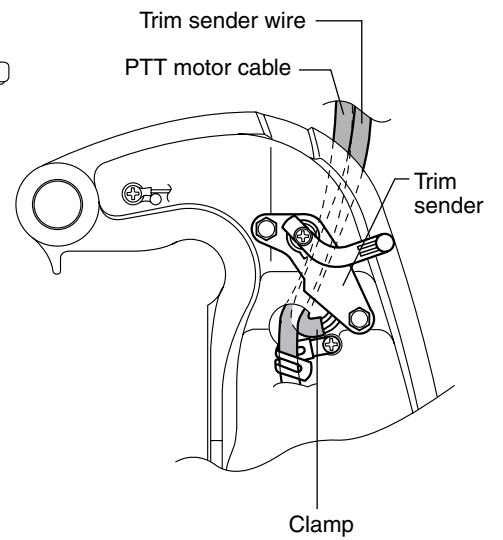
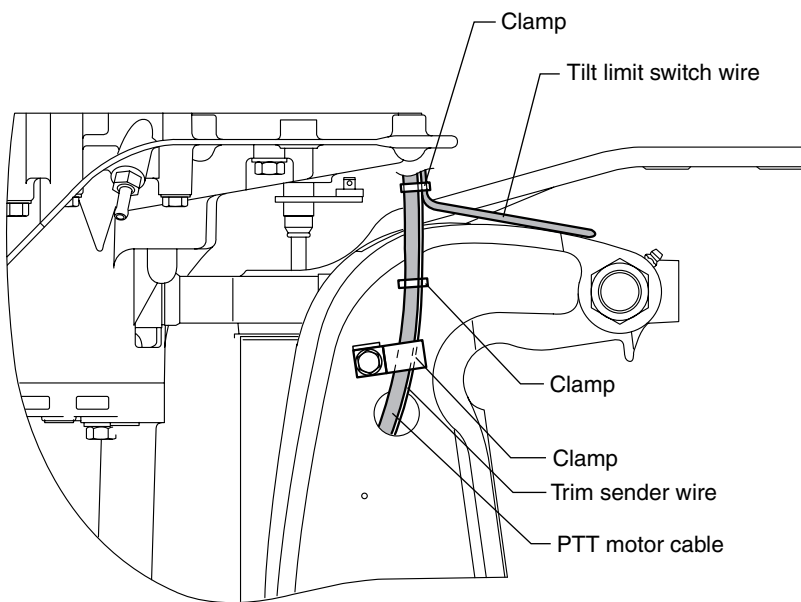
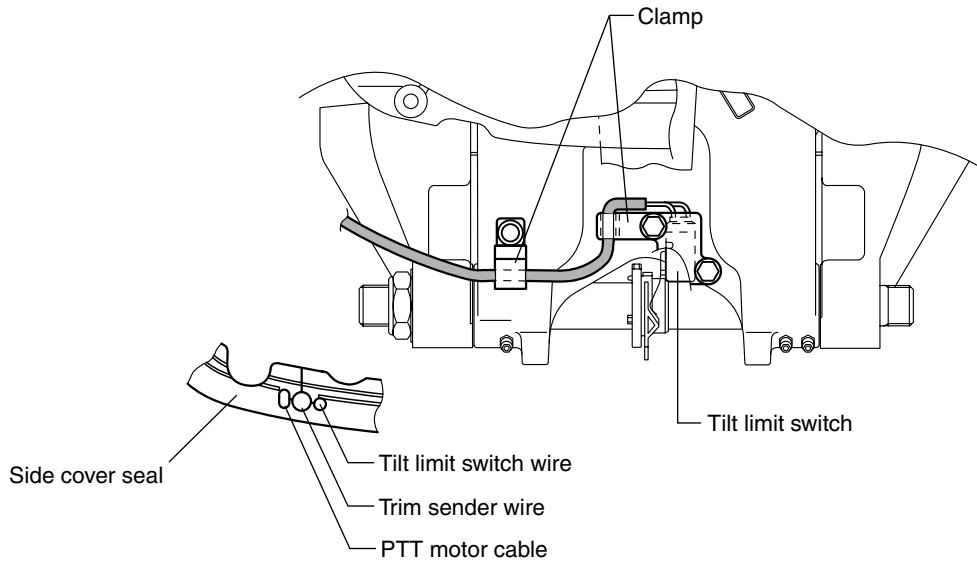

FUEL/WATER HOSE ROUTING

CAUTION

- Do not over-bend (kink) or twist hose when installing.
- When installing hose clips, position tabs to avoid contact with other parts.
- Check that hoses do not contact rods and levers during either engine operation or standstill.
- Extreme care should be taken not to cut, abrade or cause any other damage on hoses.
- Care should be taken not to cause hoses to be compressed excessively by any clamp when fitted.

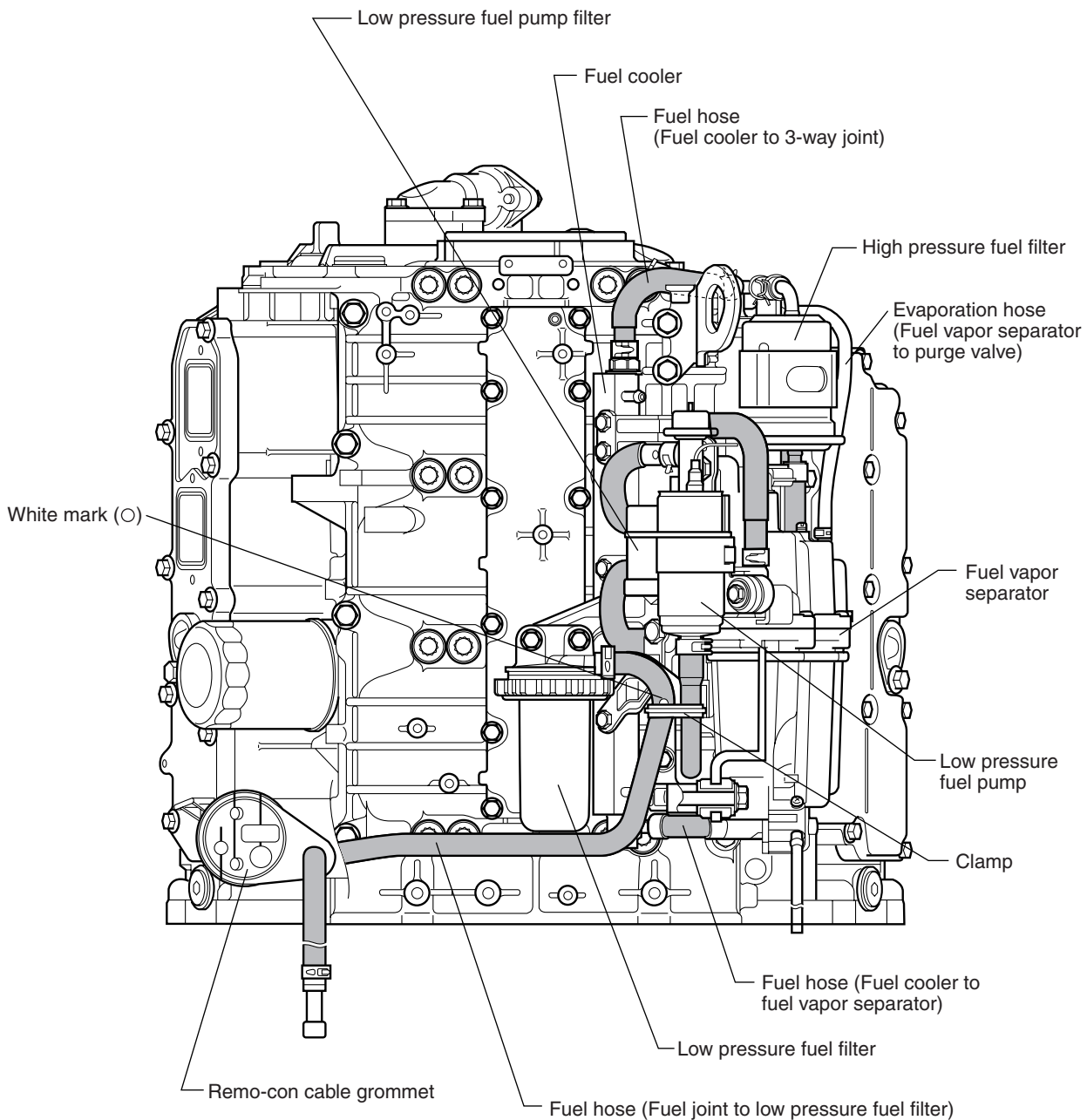

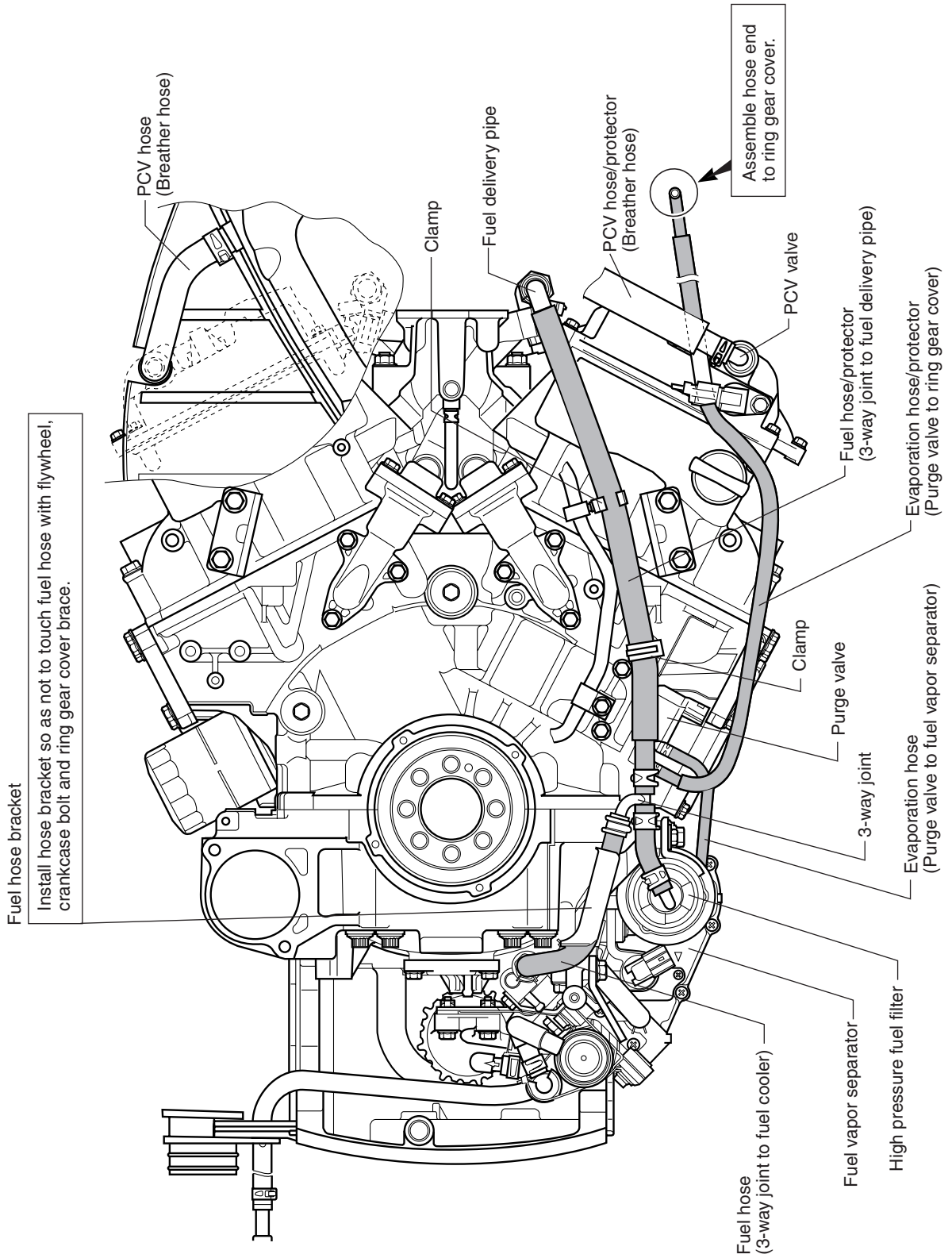

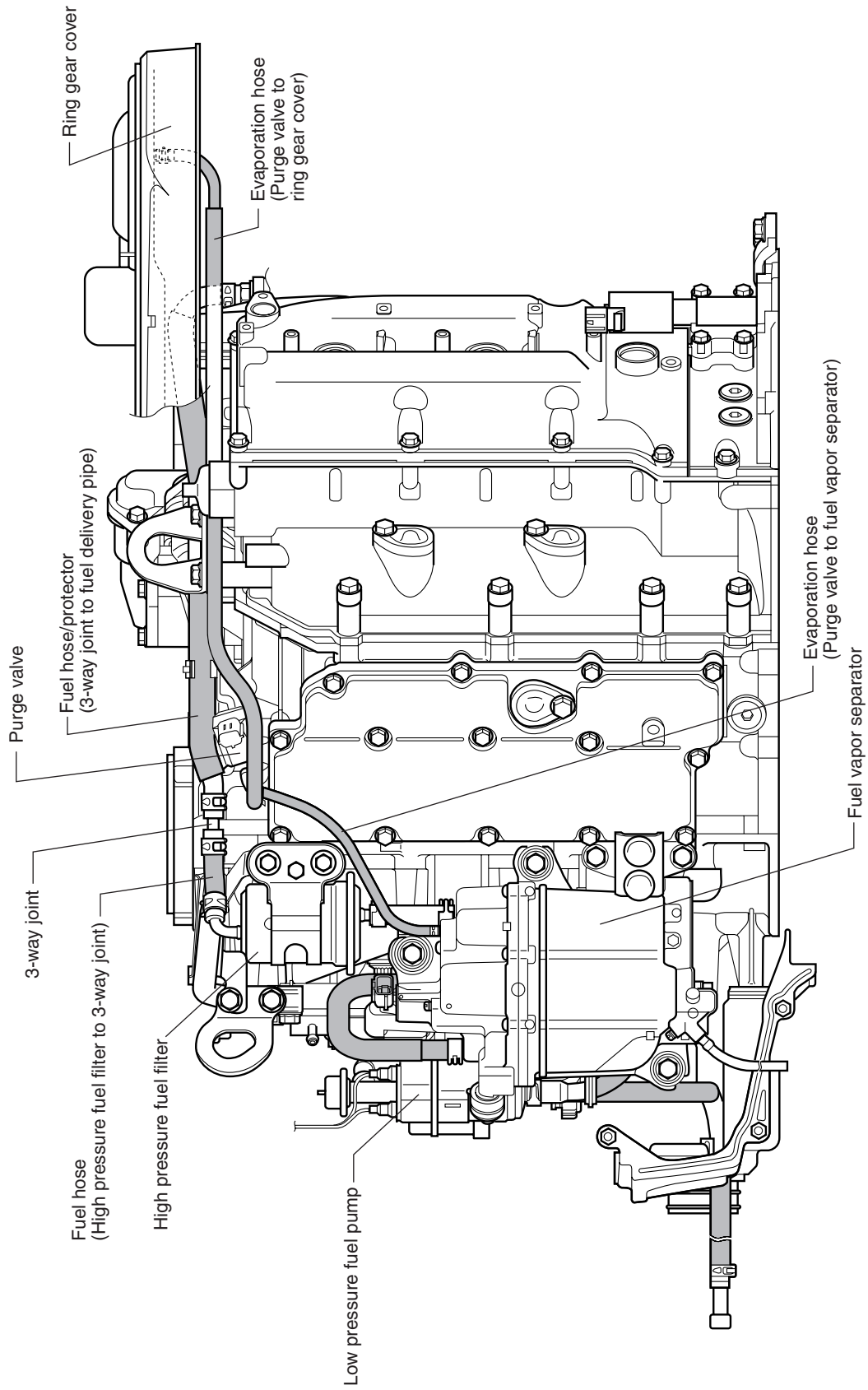

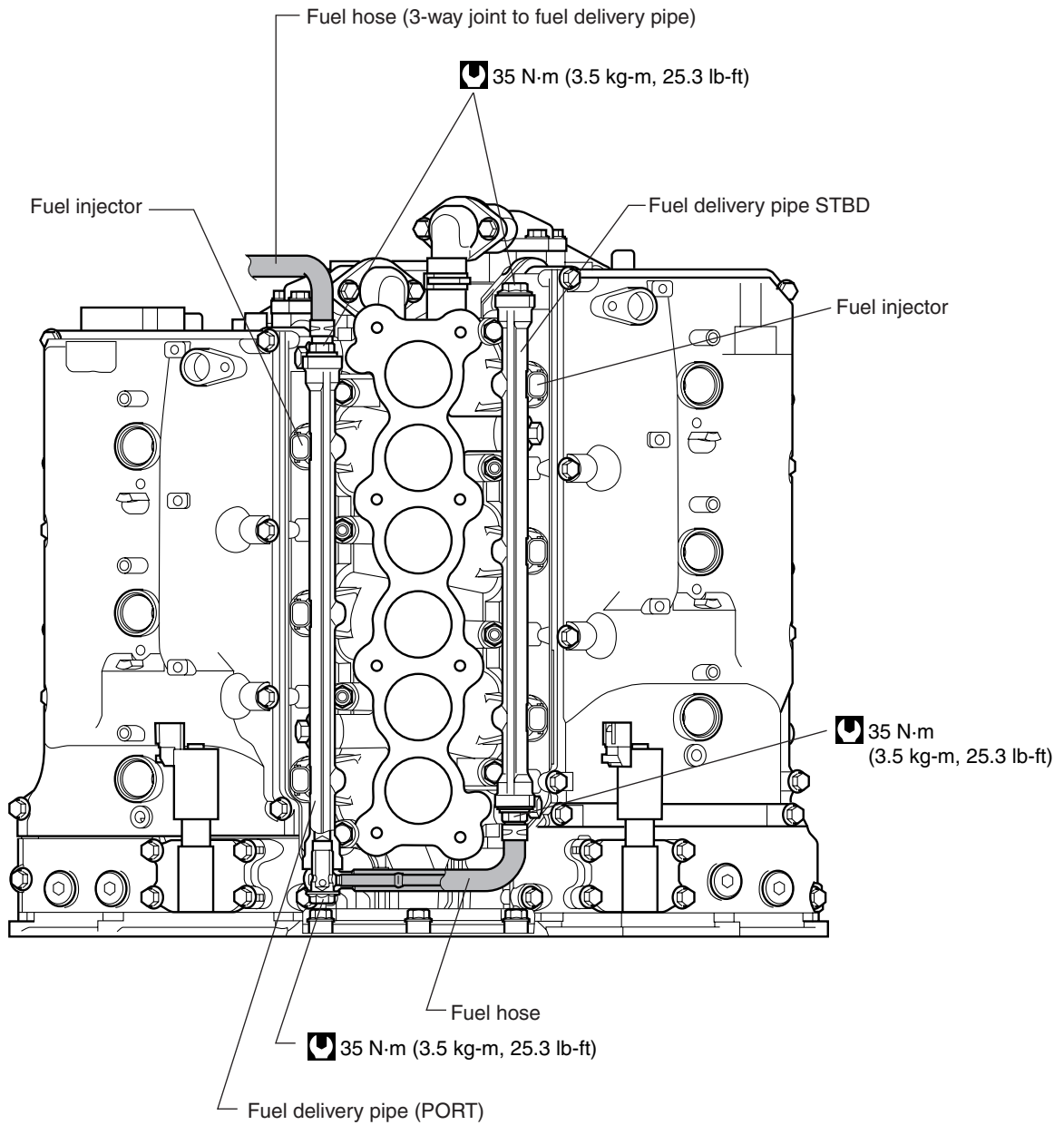

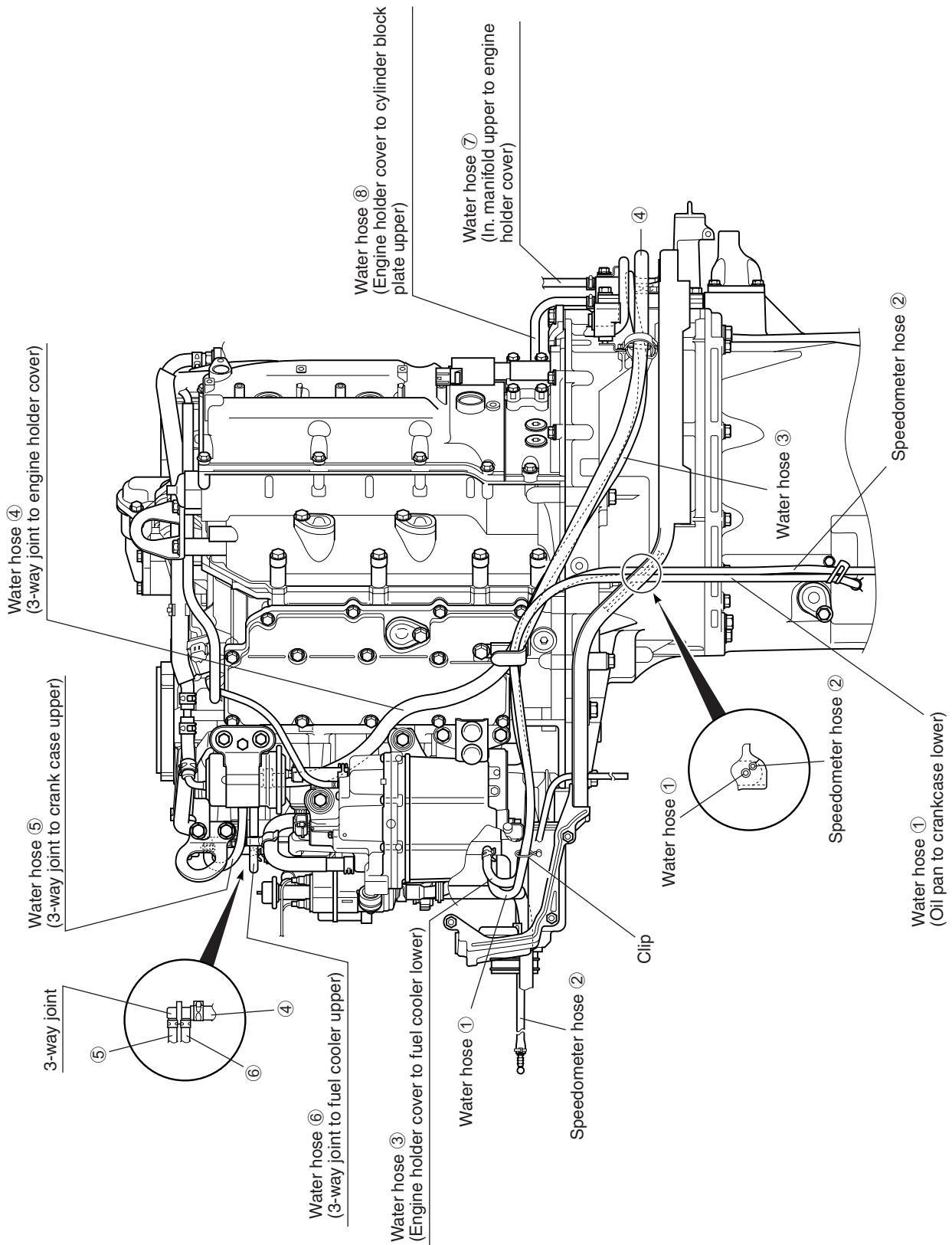

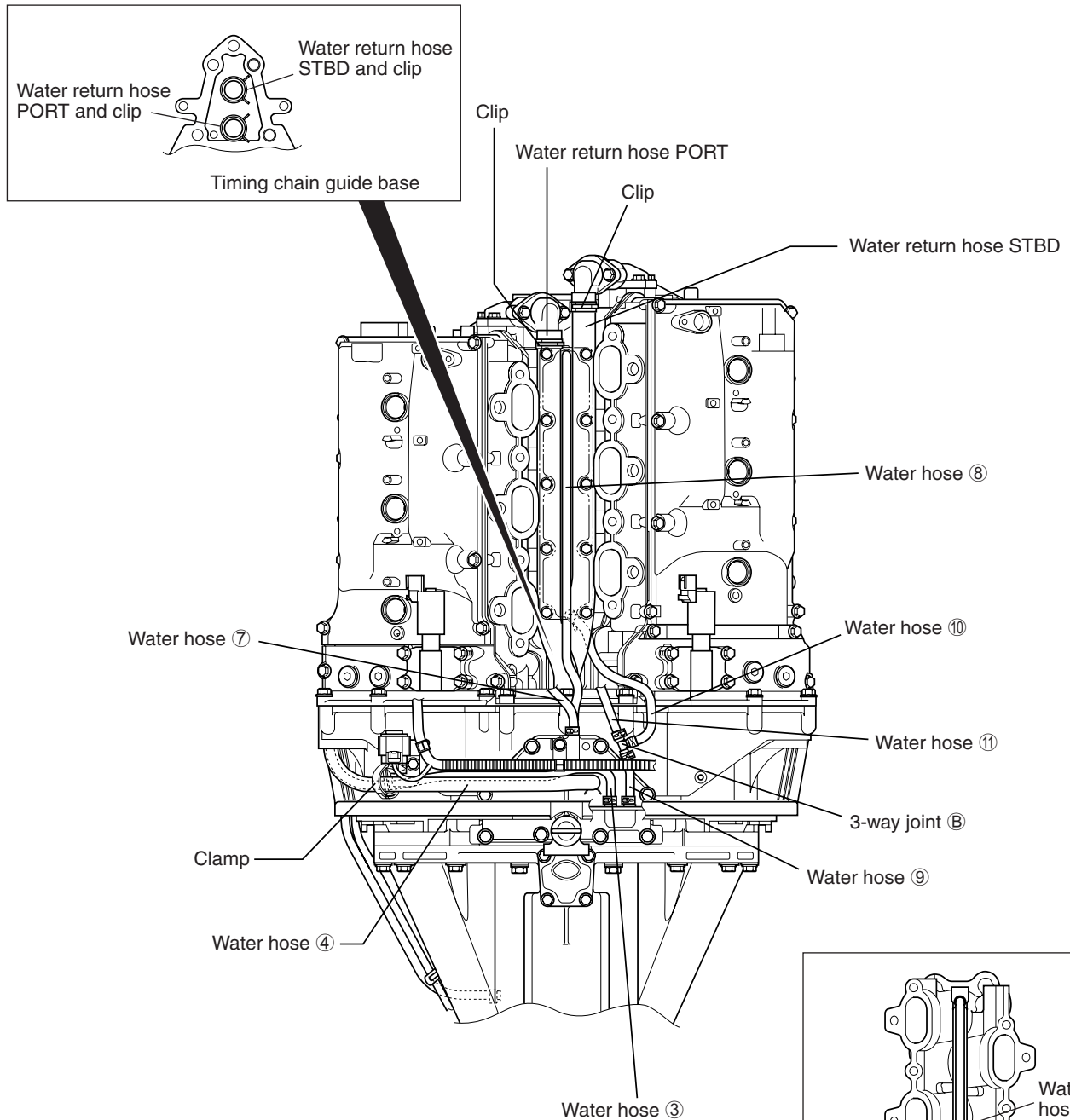

- Water hose ③: Engine holder cover to fule cooler lower
- Water hose ④: 3-way joint to engine holder cover
- Water hose ⑦: In. manifold upper to engine holder cover
- Water hose ⑧: Engine holder cover to cylinder block plate upper
- Water hose ⑨: Engine holder cover to 3-way joint B
- Water hose ⑩: Engine holder cover to cylinder block plate lower
- Water hose ⑪: 3-way joint B to In. manifold lower

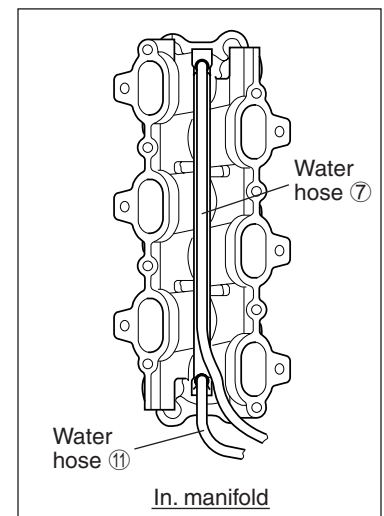

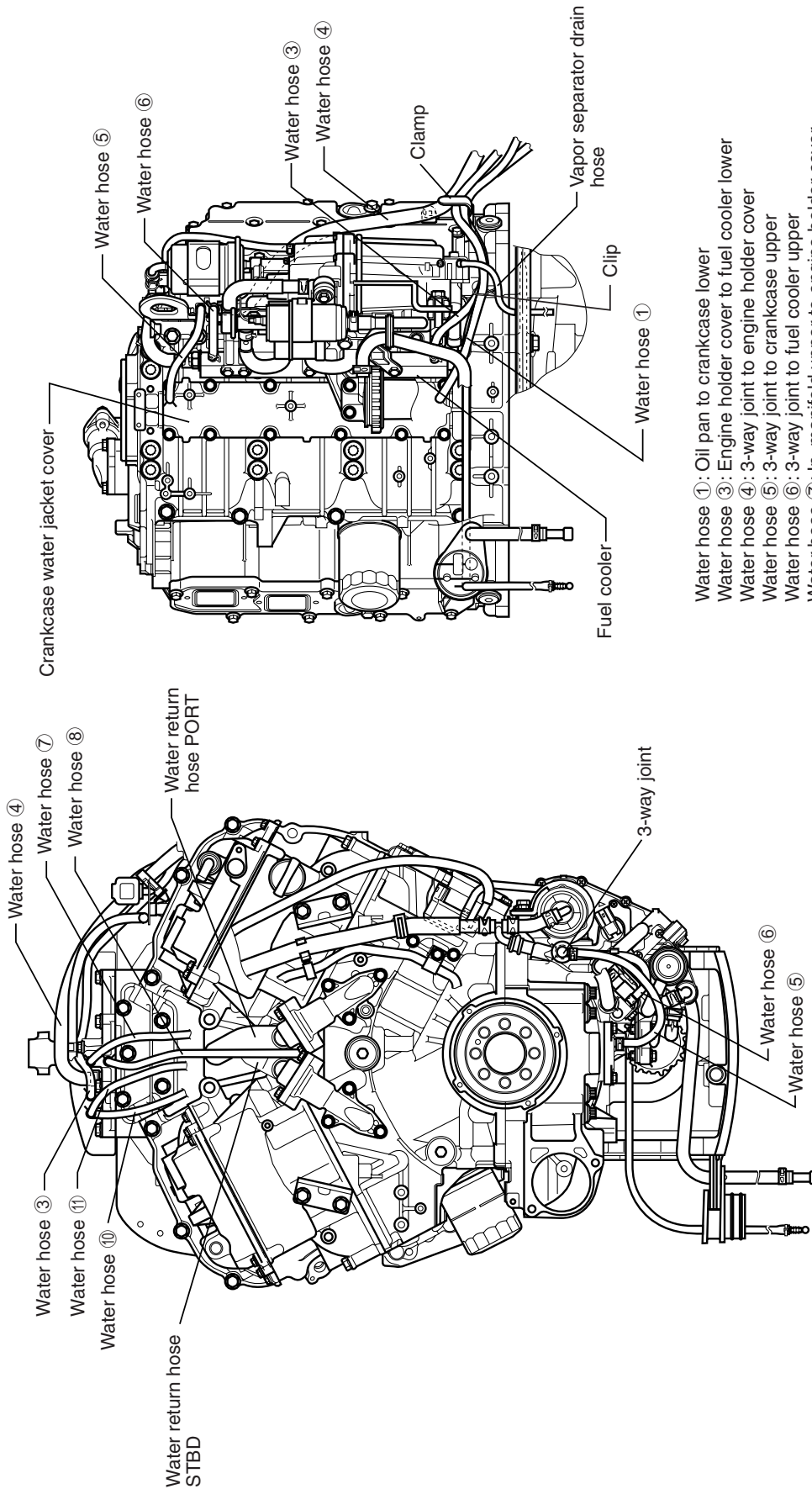

- Water hose ①: Oil pan to crankcase lower
- Water hose ③: Engine holder cover to fuel cooler lower
- Water hose ④: 3-way joint to engine holder cover
- Water hose ⑤: 3-way joint to crankcase upper
- Water hose ⑥: 3-way joint to fuel cooler upper
- Water hose ⑦: In. manifold upper to engine holder cover
- Water hose ⑧: Engine holder cover to cylinder block plate upper
- Water hose ⑩: 3-way joint ⑥ to In. manifold lower

SUZUKI MOTOR CORPORATION