

Item	Unit	Data		
		DF200T/Z/WT/WZ	DF225T/Z/WT/WZ	DF250T/Z

POWERHEAD

Recommended operating range	r/min	5000 – 6000	5000 – 6000	5500 – 6100
Idle speed	r/min	650 ± 50 (in-gear: Approx. 650)		
* Cylinder compression	kPa (kg/cm ² , psi)	1100 – 1700 (11 – 17, 156 – 242)		
* Cylinder compression max. difference between any other cylinders	kPa (kg/cm ² , psi)	100 (1.0, 14)		
* Engine oil pressure	kPa (kg/cm ² , psi)	400 – 600 (4.0 – 6.0, 57 – 85) at 3000 r/min (at normal operating temp.)		
Engine oil		API classification SE, SF, SG, SH, SJ Viscosity rating SAE 10W-40		
Engine oil amounts	L (US/lpm. qt)	8.0 (8.5/7.0) : Oil change only 8.2 (8.7/7.2) : Oil filter change		
Thermostat operating temperature	°C (°F)	58 – 62 (136 – 144)		

* Figures shown are guidelines only, not absolute service limits.

Item	Unit	Data		
		DF200T/Z/WT/WZ	DF225T/Z/WT/WZ	DF250T/Z

CYLINDER HEAD/CAMSHAFT

Cylinder head distortion	Limit	mm (in)	0.03 (0.001)			
Manifold seating faces distortion	Limit	mm (in)	0.10 (0.004)			
Cam height	IN	STD	mm (in)	43.020 – 43.180 (1.6937 – 1.7000)	42.420 – 42.580 (1.6701 – 1.6764)	44.920 – 45.080 (1.7685 – 1.7748)
		Limit	mm (in)	42.920 (1.6898)	42.320 (1.6661)	44.820 (1.7646)
	EX	STD	mm (in)	43.620 – 43.780 (1.7173 – 1.7236)	43.620 – 43.780 (1.7173 – 1.7236)	44.420 – 44.580 (1.7488 – 1.7551)
		Limit	mm (in)	43.520 (1.7134)	43.520 (1.7134)	44.320 (1.7449)
Camshaft journal oil clearance	Top, 2nd, 3rd, 4th	STD	mm (in)	0.043 – 0.085 (0.0017 – 0.0033)		
		Limit	mm (in)	0.120 (0.0047)		
Camshaft journal (housing) inside diameter	Top, 2nd, 3rd, 4th	STD	mm (in)	26.000 – 26.021 (1.0236 – 1.0244)		
		Limit	mm (in)	—		
Camshaft journal outside diameter	Top, 2nd, 3rd, 4th	STD	mm (in)	25.936 – 25.957 (1.0211 – 1.0219)		
		Limit	mm (in)	—		
Camshaft runout	Limit	mm (in)	0.10 (0.004)			
Cylinder head bore to tappet clearance	STD	mm (in)	0.025 – 0.066 (0.0010 – 0.0026)			
	Limit	mm (in)	0.150 (0.0059)			
Tappet outer diameter	STD	mm (in)	33.959 – 33.975 (1.3370 – 1.3376)			
Cylinder head bore	STD	mm (in)	34.000 – 34.025 (1.3386 – 1.3396)			

Item	Unit	Data		
		DF200T/Z/WT/WZ	DF225T/Z/WT/WZ	DF250T/Z

VALVE/VALVE GUIDE

Valve diameter	IN		mm (in)	35.9 (1.41)
	EX		mm (in)	31.4 (1.24)
Tappet clearance (Cold engine condition)	IN	STD	mm (in)	0.23 – 0.27 (0.009 – 0.011)
	EX	STD	mm (in)	0.33 – 0.37 (0.013 – 0.015)
Valve seat angle	IN		—	15°, 45°, 60°
	EX		—	15°, 45°, 60°
Valve guide to valve stem clearance	IN	STD	mm (in)	0.020 – 0.047 (0.0008 – 0.0019)
		Limit	mm (in)	0.070 (0.0028)
	EX	STD	mm (in)	0.045 – 0.072 (0.0018 – 0.0028)
		Limit	mm (in)	0.090 (0.0035)
Valve guide inside diameter	IN, EX	STD	mm (in)	5.500 – 5.512 (0.2165 – 0.2170)
Valve guide protrusion	IN, EX	STD	mm (in)	11.4 – 11.8 (0.45 – 0.46)
Valve stem outside diameter	IN	STD	mm (in)	5.465 – 5.480 (0.2152 – 0.2157)
	EX	STD	mm (in)	5.440 – 5.455 (0.2142 – 0.2148)
Valve stem deflection	IN	Limit	mm (in)	0.14 (0.006)
	EX	Limit	mm (in)	0.18 (0.007)
Valve stem runout	IN, EX	Limit	mm (in)	0.05 (0.002)
Valve head radial runout	IN, EX	Limit	mm (in)	0.08 (0.003)
Valve head thickness	IN	STD	mm (in)	1.1 (0.04)
		Limit	mm (in)	0.7 (0.03)
	EX	STD	mm (in)	1.05 (0.04)
		Limit	mm (in)	0.7 (0.03)
Valve seat contact width	IN	STD	mm (in)	1.1 – 1.3 (0.04 – 0.05)
	EX	STD	mm (in)	1.1 – 1.3 (0.04 – 0.05)
Valve spring free length		STD	mm (in)	40.2 (1.58)
		Limit	mm (in)	38.6 (1.52)
Valve spring tension		STD	N (kg, lbs)	150 – 177 (15.0 – 17.7, 33.1 – 39.0) for 31.1 mm (1.22 in)
		Limit	N (kg, lbs)	139 (13.9, 30.6) for 31.1 mm (1.22 in)
Valve spring squareness		Limit	mm (in)	2.0 (0.08)

Item	Unit	Data		
		DF200T/Z/WT/WZ	DF225T/Z/WT/WZ	DF250T/Z

CYLINDER/PISTON/PISTON RING

Cylinder distortion	Limit	mm (in)	0.05 (0.002)
Piston to cylinder clearance	STD	mm (in)	0.020 – 0.040 (0.0008 – 0.0016)
	Limit	mm (in)	0.100 (0.0039)
Cylinder bore	STD	mm (in)	95.000 – 95.020 (3.7402 – 3.7409)
Cylinder measuring position		mm (in)	50 (2.0) from cylinder top surface
Piston skirt diameter	STD	mm (in)	94.970 – 94.990 (3.7390 – 3.7398)
Piston measuring position		mm (in)	8 (0.3) from piston skirt end
Cylinder bore wear	Limit	mm (in)	0.100 (0.0039)
Piston ring end gap	1st	STD	0.20 – 0.33 (0.008 – 0.013)
		Limit	0.70 (0.028)
	2nd	STD	0.33 – 0.48 (0.013 – 0.019)
		Limit	1.00 (0.039)
Piston ring free end gap	1st	STD	Approx. 11.7 (0.46)
		Limit	9.3 (0.37)
	2nd	STD	Approx. 13.2 (0.52)
		Limit	10.5 (0.41)
Piston ring to groove clearance	1st	STD	0.030 – 0.070 (0.0012 – 0.0028)
		Limit	0.12 (0.005)
	2nd	STD	0.020 – 0.060 (0.0008 – 0.0024)
		Limit	0.10 (0.004)
Piston ring groove width	1st	STD	1.22 – 1.24 (0.048 – 0.049)
	2nd	STD	1.21 – 1.23 (0.0476 – 0.0484)
	Oil	STD	2.51 – 2.53 (0.099 – 0.100)
Piston ring thickness	1st	STD	1.17 – 1.19 (0.046 – 0.047)
	2nd	STD	1.17 – 1.19 (0.046 – 0.047)
Pin clearance in piston pin hole	STD	mm (in)	0.006 – 0.017 (0.0002 – 0.0007)
	Limit	mm (in)	0.040 (0.0016)
Piston pin outside diameter	STD	mm (in)	21.996 – 22.000 (0.8660 – 0.8661)
	Limit	mm (in)	21.980 (0.8654)
Piston pin hole diameter	STD	mm (in)	22.006 – 22.014 (0.8664 – 0.8667)
	Limit	mm (in)	22.030 (0.8673)
Pin clearance in conrod small end	STD	mm (in)	0.003 – 0.014 (0.0001 – 0.0006)
	Limit	mm (in)	0.050 (0.0020)
Conrod small end bore	STD	mm (in)	22.003 – 22.011 (0.8663 – 0.8666)

Item	Unit	Data		
		DF200T/Z/WT/WZ	DF225T/Z/WT/WZ	DF250T/Z

CRANKSHAFT/CONROD

Conrod small end inside diameter	STD	mm (in)	22.003 – 22.011 (0.8663 – 0.8666)
Conrod big end oil clearance	STD	mm (in)	0.045 – 0.063 (0.0018 – 0.0025)
	Limit	mm (in)	0.080 (0.0031)
Conrod big end inside diameter	STD	mm (in)	57.000 – 57.018 (2.2441 – 2.2448)
Crank pin outside diameter	STD	mm (in)	53.982 – 54.000 (2.1253 – 2.1260)
Crank pin outside diameter difference (out-of-round and taper)	Limit	mm (in)	0.010 (0.0004)
Conrod bearing thickness	STD	mm (in)	1.482 – 1.497 (0.0583 – 0.0589)
Conrod big end side clearance	STD	mm (in)	0.300 – 0.450 (0.0118 – 0.0177)
	Limit	mm (in)	0.550 (0.0217)
Conrod big end width	STD	mm (in)	20.750 – 20.800 (0.8169 – 0.8189)
Crank pin width	STD	mm (in)	21.100 – 21.200 (0.8307 – 0.8346)
Crankshaft center journal runout	Limit	mm (in)	0.04 (0.002)
Crankshaft journal oil clearance	STD	mm (in)	0.024 – 0.044 (0.0009 – 0.0017)
	Limit	mm (in)	0.065 (0.0026)
Crankcase bearing holder inside diameter	STD	mm (in)	70.000 – 70.018 (2.7559 – 2.7566)
Crankshaft journal outside diameter	STD	mm (in)	64.988 – 65.006 (2.5586 – 2.5593)
Crankshaft journal outside diameter difference (out-of-round and taper)	Limit	mm (in)	0.010 (0.0004)
Crankshaft bearing thickness	STD	mm (in)	2.496 – 2.512 (0.0983 – 0.0989)
Crankshaft thrust play	STD	mm (in)	0.11 – 0.31 (0.004 – 0.012)
	Limit	mm (in)	0.35 (0.014)
Crankshaft thrust bearing thickness	STD	mm (in)	2.425 – 2.475 (0.0955 – 0.0974)

Item	Unit	Data		
		DF200T/Z/WT/WZ	DF225T/Z/WT/WZ	DF250T/Z

ELECTRICAL

Ignition timing	Degrees	BTDC 0 – 26 ± 3	BTDC 0 – 25 ± 3	BTDC 0 – 26 ± 3
Over revolution limiter	r/min	6200		6300
CKP sensor resistance	Ω at 20°	168 – 252		
CMP sensor resistance	Ω at 20°	—		
Ignition coil resistance	Primary	Ω at 20°	—	
	Secondary	kΩ at 20°	—	
Battery charge coil resistance	Ω at 20°	0.21 – 0.32		
Battery charge coil output (12V)	Watt	648		
Standard spark plug	Type	NGK	BKR6E	
	Gap	mm (in)	0.7 – 0.8 (0.028 – 0.031)	
Fuse amp. rating	A	Main fuse: 60 Sub fuse: 30		
Recommended battery capacity (12V)	Ah (kC)	100 (360) or larger		
Fuel injector resistance	Ω at 20 °C	10 – 14		
IAC valve resistance	Ω at 20 °C	25 – 34		
IAT sensor/Cylinder temp. sensor/Ex. mani. temp. sensor (Thermistor characteristic)	kΩ at 25 °C	1.8 – 2.3		
ECM main relay coil resistance	Ω at 20 °C	145 – 190		
Starter motor relay coil resistance	Ω at 20 °C	145 – 190		
PTT motor relay coil resistance	Ω at 20 °C	25 – 37		

STARTER MOTOR















Max. continuous time of use	Sec.	30		
Motor output	kW	1.4		
Brush length	STD	mm (in)	16.0 (0.63)	
	Limit	mm (in)	12.0 (0.47)	
Commutator undercut	STD	mm (in)	0.5 – 0.8 (0.02 – 0.03)	
	Limit	mm (in)	0.2 (0.01)	
Commutator outside diameter	STD	mm (in)	29.0 (1.14)	
	Limit	mm (in)	28.0 (1.10)	
Commutator outside diameter difference	STD	mm (in)	0.05 (0.002)	
	Limit	mm (in)	0.40 (0.016)	

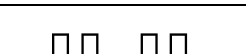

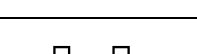

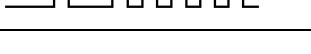

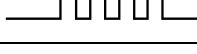

PTT MOTOR

Brush length	STD	mm (in)	9.8 (0.39)
	Limit	mm (in)	5.5 (0.22)
Commutator outside diameter	STD	mm (in)	22.0 (0.87)
	Limit	mm (in)	21.0 (0.83)

SELF-DIAGNOSTIC SYSTEM INDICATION

When the abnormality occurs in a signal from sensor, switch, etc., the "CHECK ENGINE" lamp on the monitor-tachometer flashes (lights intermittently) according to the each code pattern with buzzer sounding.

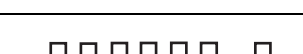
PRIORITY *	FAILED ITEM	CODE	LAMP FLASHING PATTERN	FAIL-SAFE SYSTEM ACTIVATING
1	MAP sensor 1	3 - 4	on off 	YES
2	IAC valve/By-pass air screw adjustment	3 - 1	on off 	NO
3	Cylinder temp. sensor	1 - 4	on off 	YES
4	IAT sensor	2 - 3	on off 	YES
5	CKP sensor	4 - 2	on off 	YES
6	CMP sensor	2 - 4	on off 	YES
7	Air intake system	2 - 2	on off 	YES
8	MAP sensor 2 (Pressure detect passage)	3 - 2	on off 	NO
9	Rectifier & regulator (Over-charging)	1 - 1	on off 	NO
10	Exhaust manifold temp. sensor (STBD)	1 - 5	on off 	YES
11	Exhaust manifold temp. sensor (PORT)	1 - 6	on off 	YES
12	Fuel injector	4 - 3	on off 	NO
13	Throttle position sensor	2 - 1	on off 	YES
14	Shift position sensor	1 - 2	on off 	YES

PRIORITY *	FAILED ITEM	CODE	LAMP FLASHING PATTERN	FAIL-SAFE SYS- TEM ACTIVATING
15	CMP sensor (VVT·STBD)	2 – 5	on off 	YES
16	CMP sensor (VVT·PORT)	2 – 6	on off 	YES
17	VVT advance (STBD)	5 – 1	on off 	YES
18	VVT advance (PORT)	5 – 2	on off 	YES
19	Neutral switch	3 – 3	on off 	NO
20	Model discrimination	4 – 1	on off 	YES
21	Oil control valve (STBD)	6 – 1	on off 	NO
22	Oil control valve (PORT)	6 – 2	on off 	NO

** If more than two items fail at once, the self-diagnostic indication appears according to priority order.
The indication repeats three times.*