

# POWER UNIT

## CONTENTS

<b>RING GEAR COVER AND AIR INTAKE SILENCER CASE</b> .....	6- 2
<b>REMOVAL</b> .....	6- 2
<b>INSTALLATION</b> .....	6- 2
<b>INTAKE MANIFOLD ASSEMBLY</b> .....	6- 3
<b>REMOVAL</b> .....	6- 3
<b>INSTALLATION</b> .....	6- 5
<b>DISASSEMBLY</b> .....	6- 8
<b>REASSEMBLY</b> .....	6- 9
<b>CYLINDER HEAD COVER</b> .....	6-11
<b>REMOVAL</b> .....	6-11
<b>INSTALLATION</b> .....	6-13
<b>POWER UNIT</b> .....	6-15
<b>REMOVAL</b> .....	6-15
<b>INSTALLATION</b> .....	6-21
<b>OIL PUMP</b> .....	6-26
<b>REMOVAL</b> .....	6-26
<b>DISASSEMBLY</b> .....	6-27
<b>INSPECTION</b> .....	6-28
<b>MEASURING PUMP COMPONENTS</b> .....	6-28
<b>ASSEMBLY</b> .....	6-29
<b>INSTALLATION</b> .....	6-30
<b>TIMING CHAIN/BALANCER CHAIN (VVT model)</b> .....	6-31
<b>REMOVAL</b> .....	6-31
<b>INSPECTION</b> .....	6-35
<b>INSTALLATION</b> .....	6-37
<b>TIMING CHAIN/BALANCER CHAIN (Non-VVT model)</b> .....	6-44
<b>REMOVAL</b> .....	6-44
<b>INSPECTION</b> .....	6-48
<b>INSTALLATION</b> .....	6-50
<b>CYLINDER HEAD ASSEMBLY</b> .....	6-57
<b>REMOVAL</b> .....	6-57
<b>ASSEMBLY</b> .....	6-58
<b>DISASSEMBLY</b> .....	6-62
<b>INSPECTION/SERVICING</b> .....	6-63
<b>REASSEMBLY</b> .....	6-73
<b>COUNTER-BALANCER MECHANISM</b> .....	6-75
<b>REMOVAL</b> .....	6-75
<b>DISASSEMBLY</b> .....	6-76
<b>INSPECTION</b> .....	6-77
<b>ASSEMBLY</b> .....	6-78
<b>INSTALLATION</b> .....	6-81
<b>CYLINDER/CRANKSHAFT/PISTON</b> .....	6-82
<b>DISASSEMBLY</b> .....	6-82
<b>INSPECTION/SERVICING</b> .....	6-85
<b>REASSEMBLY</b> .....	6-97
<b>THERMOSTAT</b> .....	6-105
<b>REMOVAL</b> .....	6-105
<b>INSPECTION</b> .....	6-105
<b>INSTALLATION</b> .....	6-106
<b>OPERATION</b> .....	6-107
<b>WATER COOLING SYSTEM</b> .....	6-107
<b>ENGINE LUBRICATION SYSTEM</b> .....	6-108

## RING GEAR COVER AND AIR INTAKE SILENCER CASE REMOVAL

**Prior to removing Ring gear cover:**

- Disconnect battery cables from battery.

1. Loosen the clamp securing breather hose ①, then remove the breather hose from cylinder head cover ②.
2. Disconnect the intake air temp. sensor lead wire connector ③ at intake air temp. sensor.

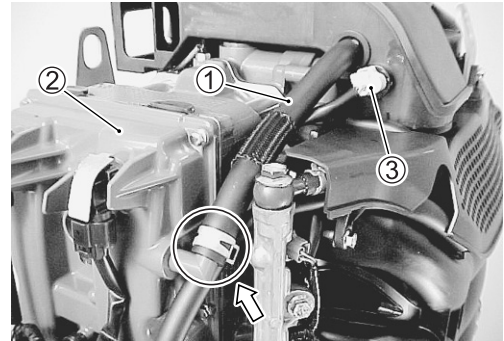

3. Remove the four (4) bolts securing ring gear cover ④.
4. Remove the ring gear cover and intake silencer case.

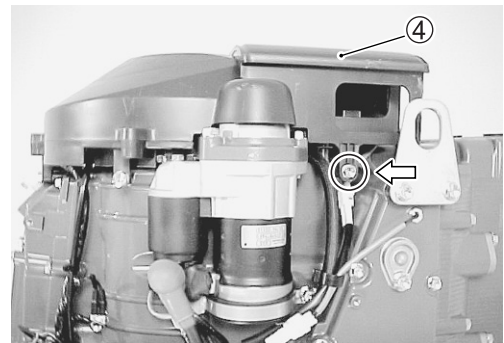
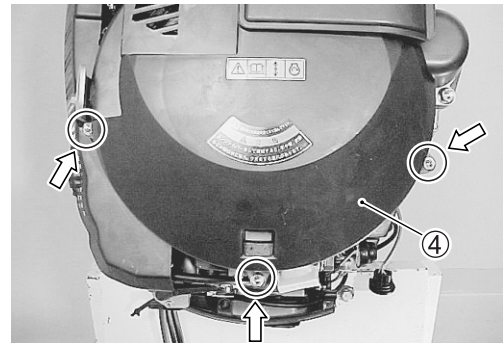

## INSTALLATION

Installation is reverse order of removal.

## INTAKE MANIFOLD ASSEMBLY REMOVAL

### Before removing intake manifold:

- Relieve fuel pressure. (See page 5-3.)
- Disconnect battery cables from battery.
- Remove both side covers. (See page 7-2.)

1. Remove ring gear cover and air intake silencer case ①.  
(See page 6-2.)  
Remove the three (3) bolts and fuel hose guard ②.

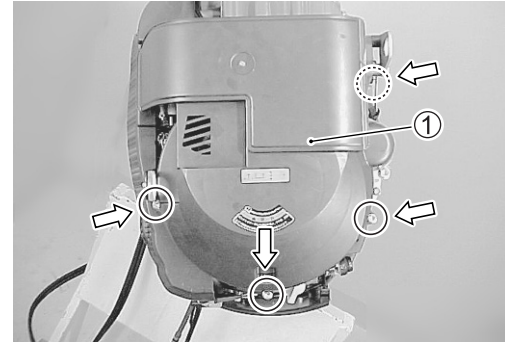

2. Remove the two (2) bolts and front panel ③.  
Remove fuel vapor separator ④. (See page 5-7.)

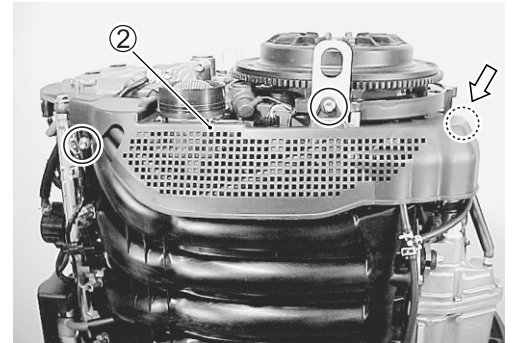

3. Remove fuel injectors ⑤ and fuel delivery pipe ⑥.  
(See page 5-14.)

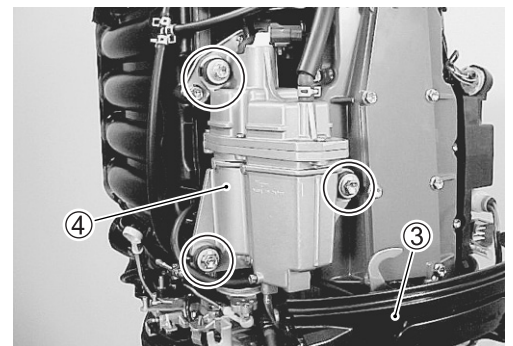

4. Disconnect fuel outlet hose ⑦ from low pressure fuel pump ⑧.

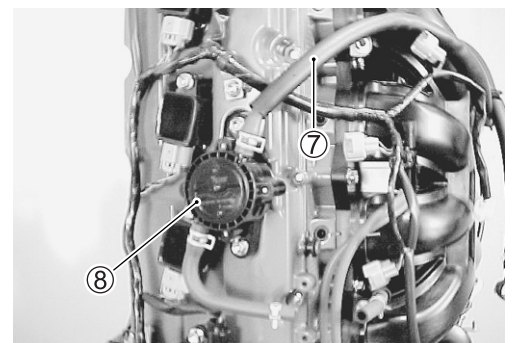
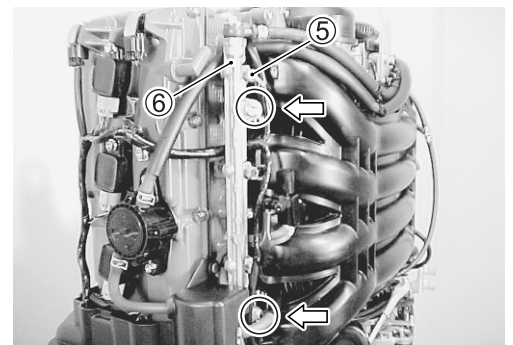

5. Disconnect VSV (Vacuum Switching Valve) connector from VSV ⑨.

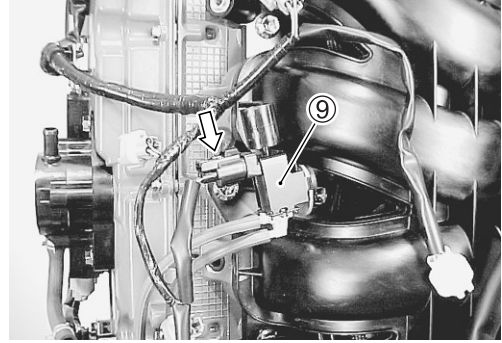

6. Disconnect MAP sensor connector ⑩.  
Disconnect IAC valve connector ⑪.  
Disconnect TPS (Throttle Position Sensor) connector ⑫.

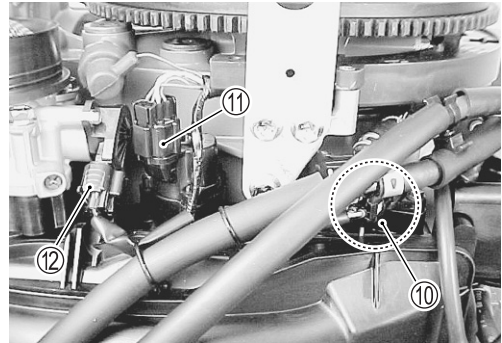

7. Disconnect vacuum hoses from vacuum tank ⑬.

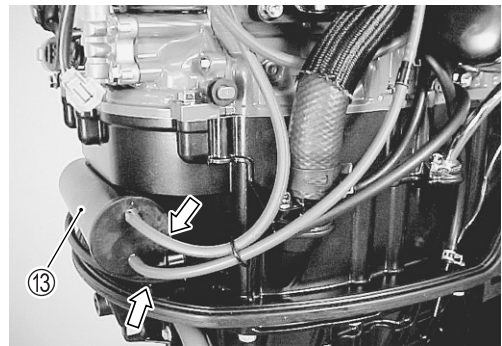

8. Remove the two bolts ⑭ securing throttle drum ⑮ to intake manifold.  
Remove the throttle link connector ⑯ from throttle drum.

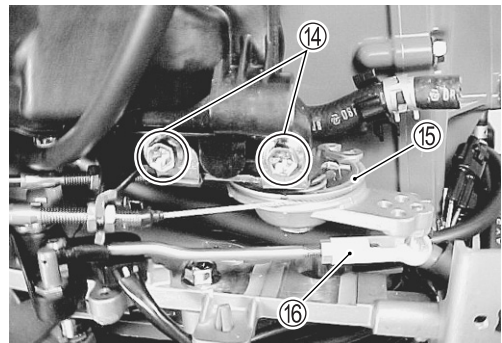

9. Disconnect water inlet hose ⑰ from fuel cooler ⑱.

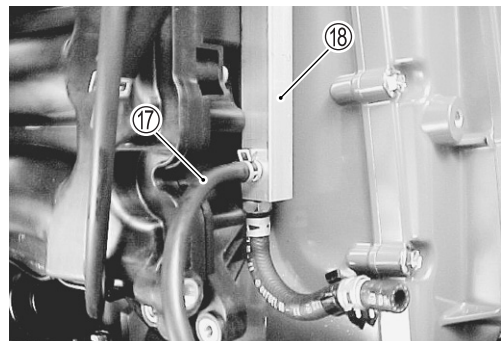



10. Disconnect cooling water outlet hose ⑱ from balancer water jacket cover ⑳.

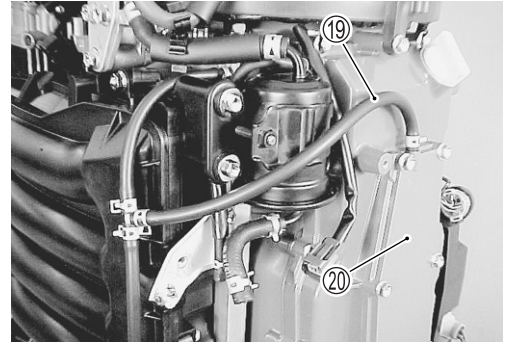

11. Disconnect water outlet hose ㉑ and water return hose ㉒ from water return union ㉓.

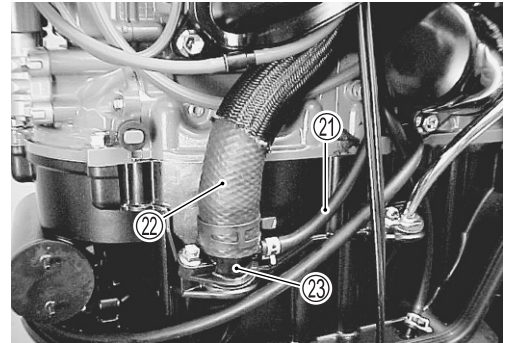

12. Remove eight (8) bolts and two (2) nuts and then remove intake manifold assembly ㉔.

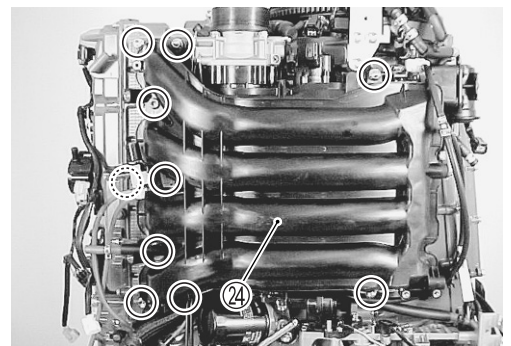

## INSTALLATION

Installation is reverse order of removal with special attention to the following steps.

### CAUTION

**Do not reuse gasket once removed.  
Always use a new gasket.**

- Install gaskets ① into groove of intake manifold assembly ②.

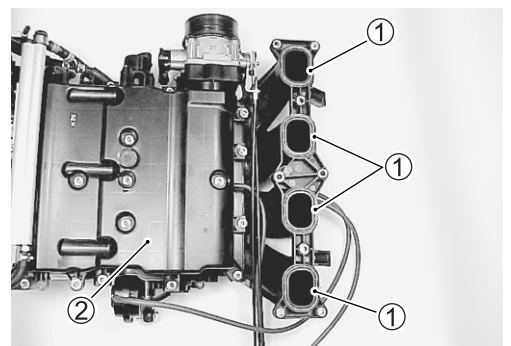

- Install intake manifold assembly ②, then tighten bolts and nuts securely.

 Intake manifold bolt & nut: 23 N-m (2.3 kg-m, 16.5 lb-ft)

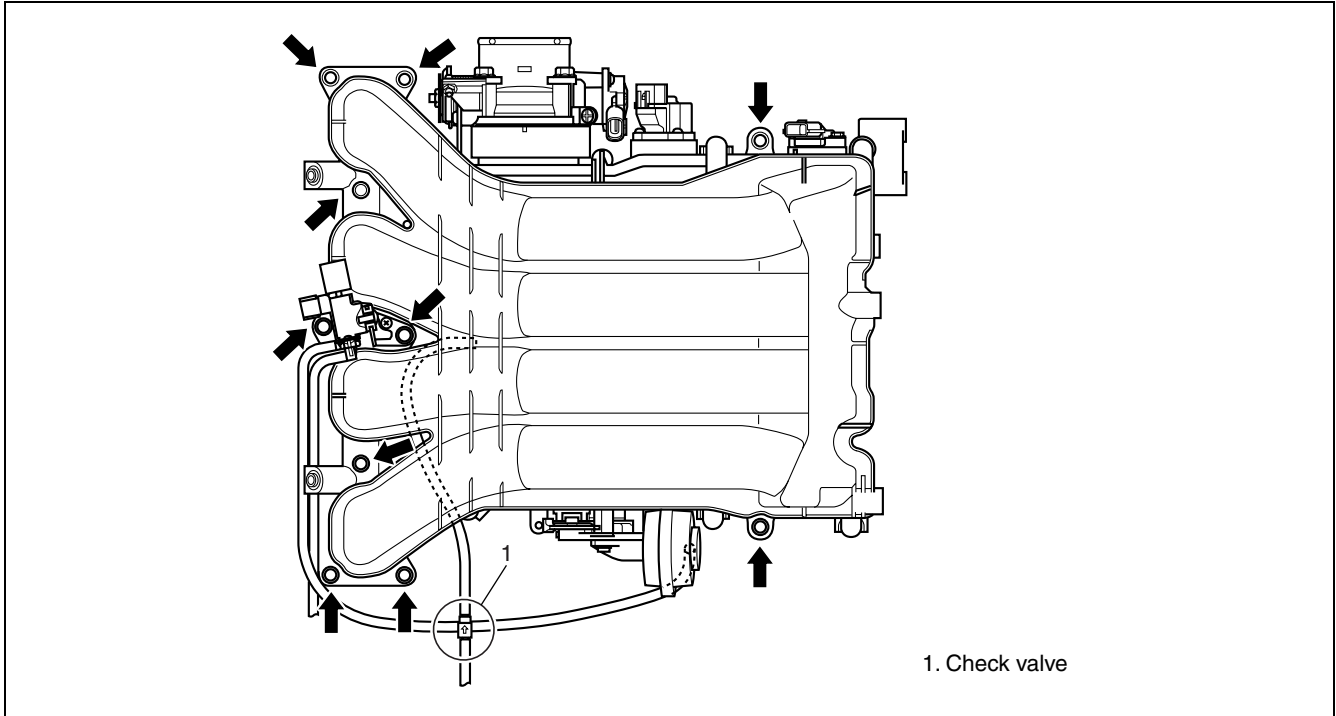
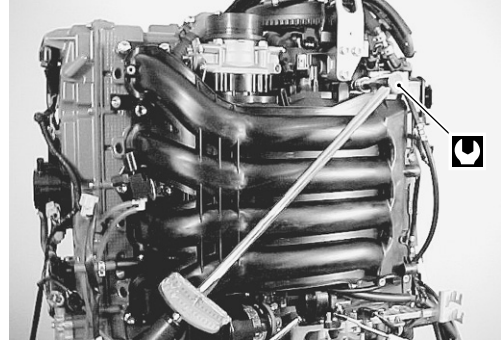

**NOTE:**

Refer to figure at right when connecting check valve between vacuum hoses.

- ① Check valve
- ② Green side
- ③ White side
- ④ To vacuum chamber
- ⑤ From intake manifold assembly

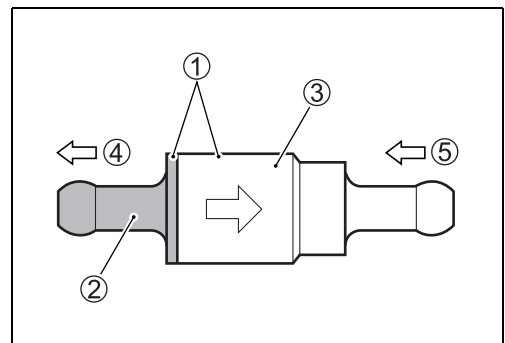

- Install fuel injectors and fuel delivery pipe. (See page 5-15.)

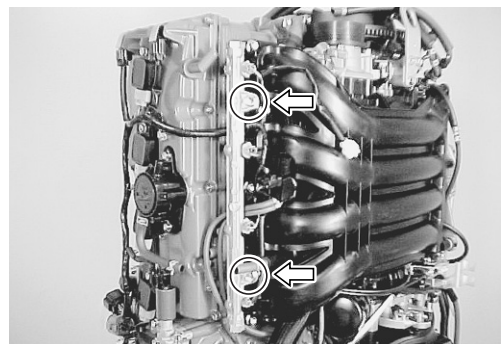

- Install fuel vapor separator. (See page 5-8.)

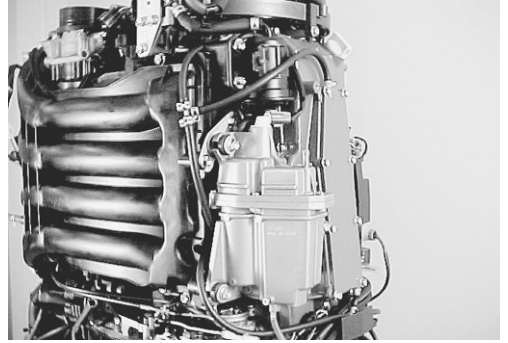

- Check to ensure that all removed parts are back in place.

#### **FINAL ASSEMBLY CHECK**

- Check fuel and water hose routing. (See page 11-11 to 11-17.)
- Check wire routing. (See page 11-4 to 11-10.)
- Check for fuel leakage.
- Check for water leakage.

## DISASSEMBLY

Remove bolts and high pressure fuel filter ①.

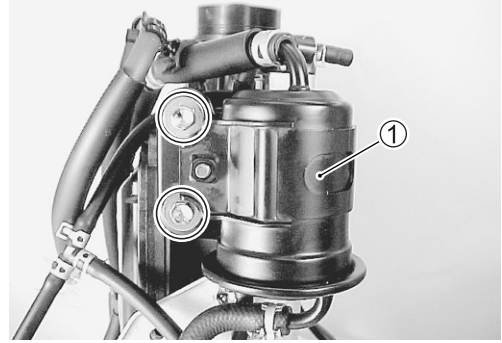

Remove bolts and fuel cooler ②.

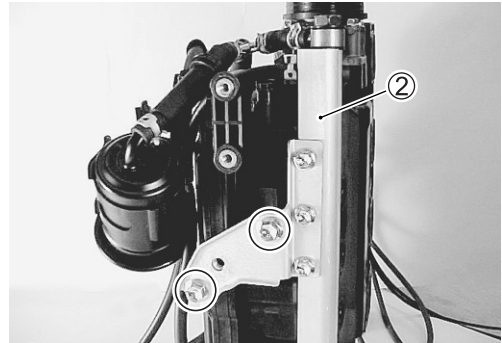

Remove screws and MAP sensor ③.

Remove screws and IAC valve ④.

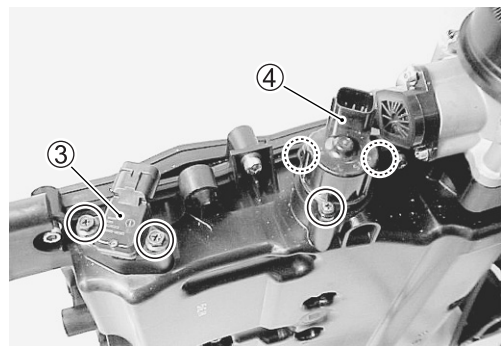

Remove flame arrester ⑤.

Remove bolts and throttle body assembly ⑥.

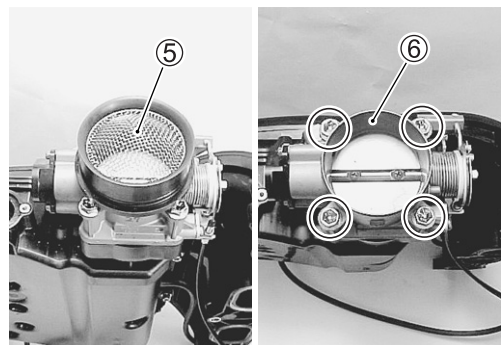

Remove screws and depression chamber ⑦.

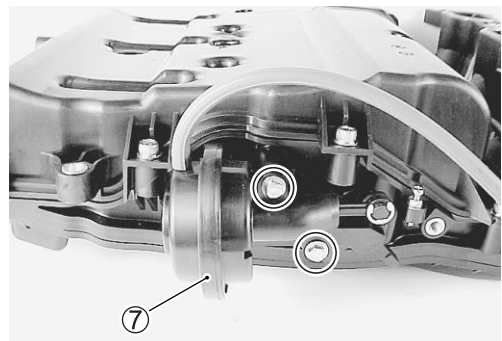



Remove the seventeen (17) screws and intake manifold cover ⑧.

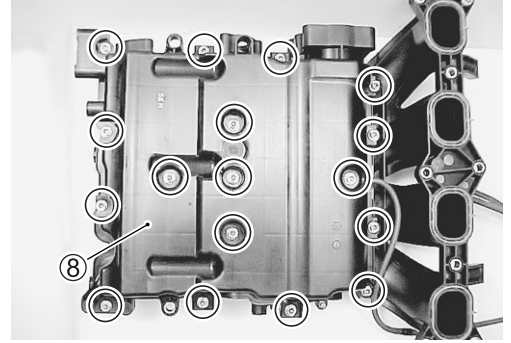

## REASSEMBLY

Reassemble in reverse order of disassembly paying special attention to the following steps.

### CAUTION

**Do not reuse gasket, always replace with new one.**

- Install new cover gasket ① to intake manifold cover.
- Install intake manifold cover ② to intake manifold, then tighten manifold cover screws securely.
- Install spacer ③ to intake manifold.

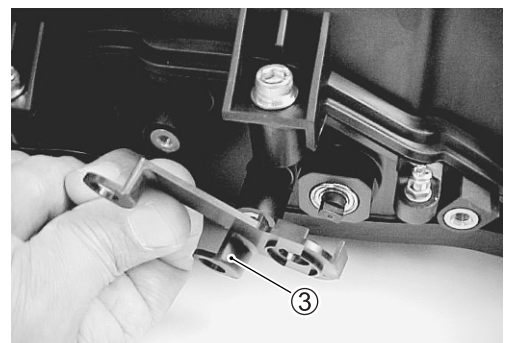
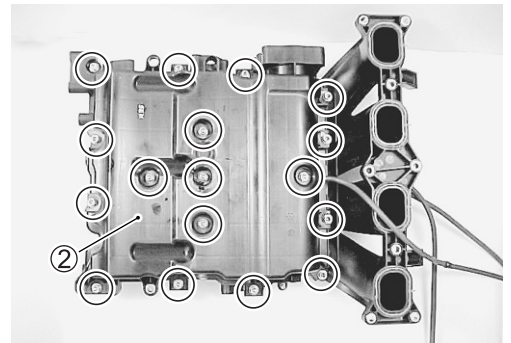
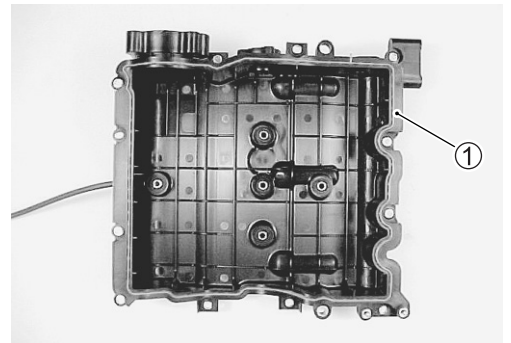

- Install the lever ④ onto the pivot shaft ⑤, use care to align hole in lever with pivot shaft end.

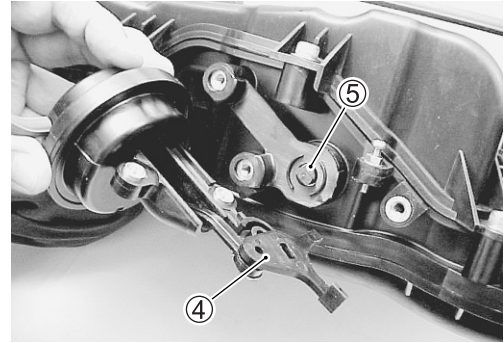

- Install depression chamber ⑥, then tighten screws securely.

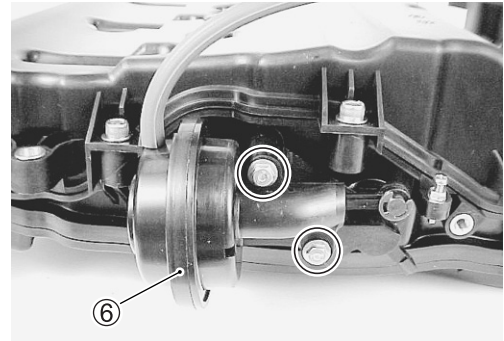

- Install seal ring ⑦ and throttle body ⑧.  
Securely tighten the four (4) throttle body bolts to specified torque.

 **Throttle body bolt: 23 N·m (2.3 kg-m, 16.6 lb-ft)**

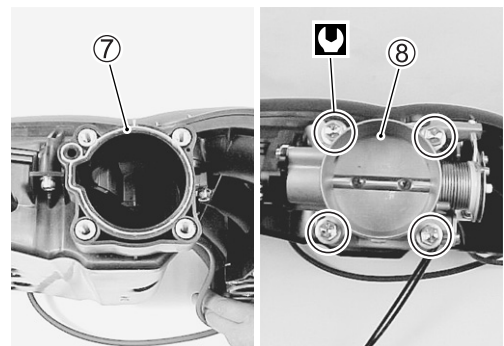

### FINAL ASSEMBLY CHECK

- All parts removed have been returned to their original positions.

## CYLINDER HEAD COVER REMOVAL

### Before removing cylinder head cover:

- Disconnect battery cables from battery.
- Remove both side covers. (See page 7-2.)

1. To remove the cover ①, pull the upper part outward, then lift up.

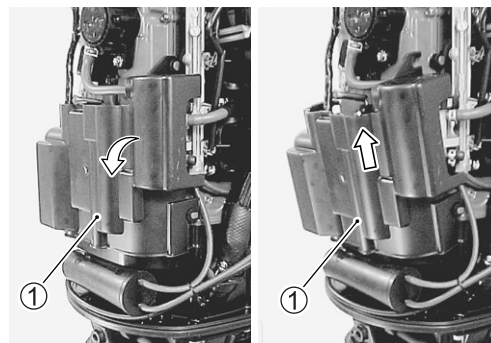

2. Remove the ring gear cover and air intake silencer case. (See page 6-2.)
3. Disconnect ignition coil connectors ②. Remove the bolts securing the ignition coils. Remove all ignition coils ③ and spark plugs.

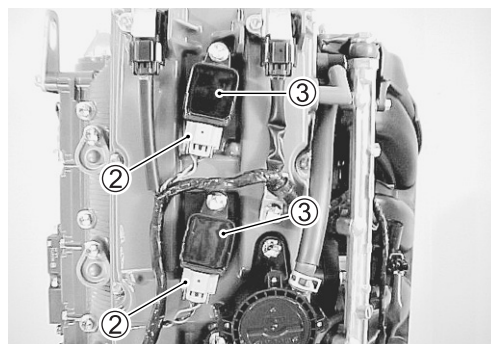

4. Disconnect inlet hose ④ and outlet hose ⑤ from low pressure fuel pump. Remove bolts and low pressure fuel pump ⑥. (See page 5-17.)

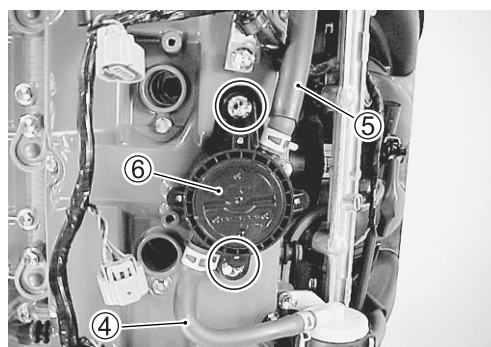

5. Remove the two bolts securing filter bracket ⑦, then remove low pressure fuel filter ⑧ and filter bracket.

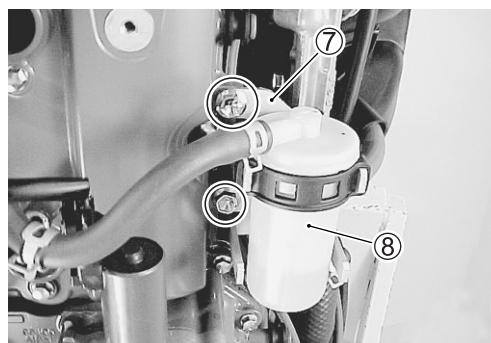

6. On DF175 model;  
disconnect IN. CMP sensor lead wire connector ⑨ at sensor.  
Remove bolt and IN. CMP sensor ⑩.
7. Disconnect EX. CMP sensor lead wire connector ⑪ at sensor.  
Remove bolt and EX. CMP sensor ⑫.
8. Remove the bolt securing lead wire clamp plate ⑬.

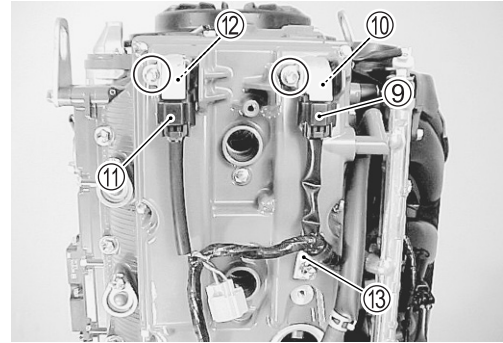

9. Remove the two bolts securing lead wire clamp plate ⑭.

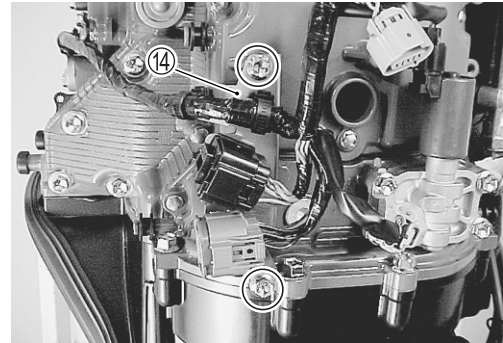

10. On DF175 model, disconnect OCV lead wire connector ⑮ at OCV.  
Remove the four (4) bolts securing OCV ⑯, then remove OCV and discard OCV gasket.

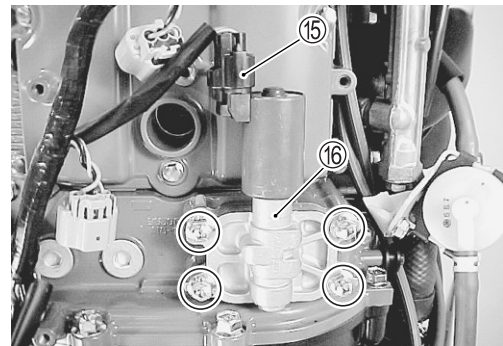

**NOTE:**

*DF150 model is not equipped with OCV.*

11. Remove the fourteen (14) bolts securing cylinder head cover ⑰ to the cylinder head, then remove the cylinder head cover.

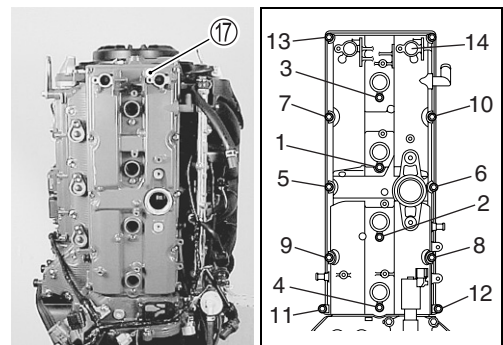



## INSTALLATION

Installation is reverse order of removal with special attention to the following steps.

- Clean sealing surface on cylinder head and cover.
- Remove oil, old sealant, and dust from sealing surfaces.
- After cleaning, apply sealant to cylinder head sealing surface area as shown in figure.

 99000-31140: SUZUKI BOND “1207B”

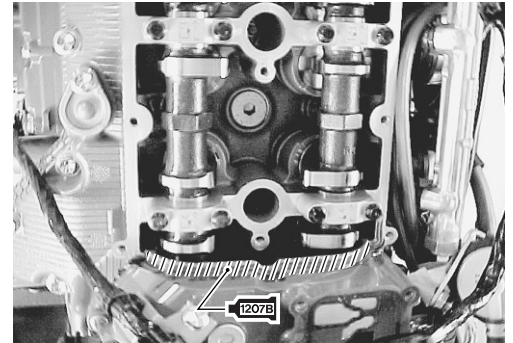
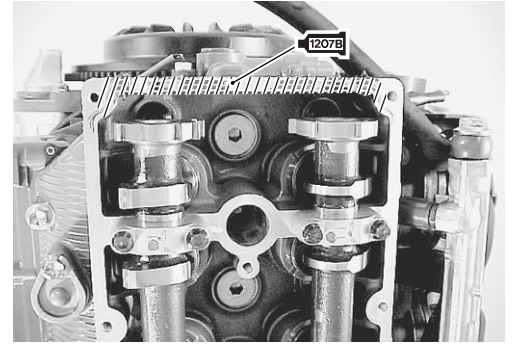

- Install new cylinder head cover gasket ① to head cover.

### NOTE:

*Examine cylinder head cover gasket for damage.  
Always replace gasket with new one.*

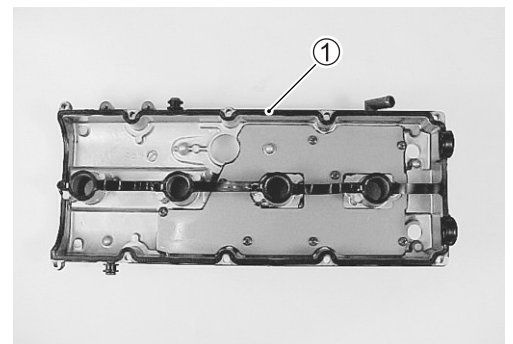

- Install cylinder head cover ② to cylinder head, then tighten cylinder head cover bolts to specified torque.

 **Cylinder head cover bolt: 11 N·m (1.1 kg·m, 8.0 lb-ft)**

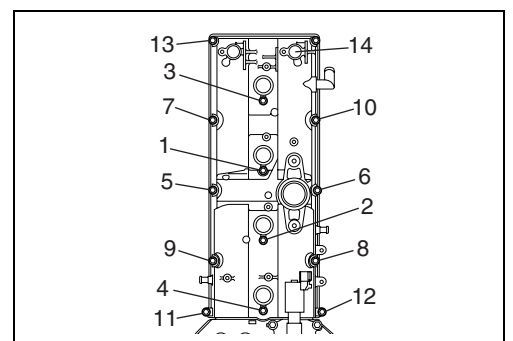
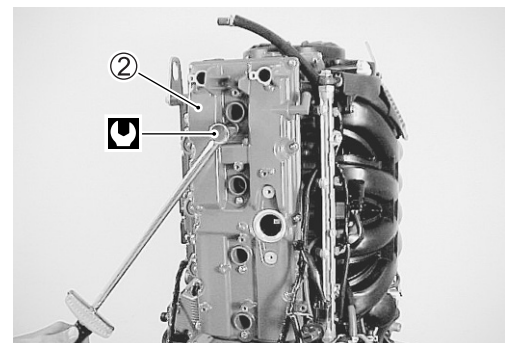

- On the DF175 model, install new gasket ③ and OCV ④, then tighten bolts securely.

**NOTE:**

*Position the OCV gasket tab as shown at right.*

**CAUTION**

**Do not reuse the OCV gasket, always replace with new one.**

- 🔩 OCV bolt: 12 N·m (1.2 kg-m, 8.7 lb-ft)

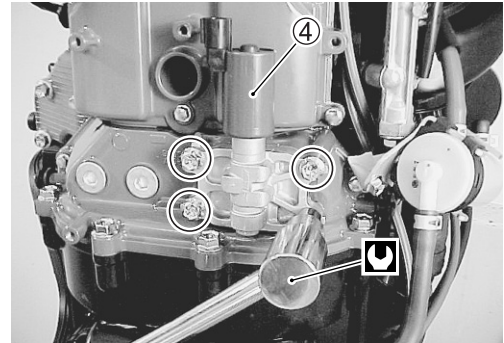
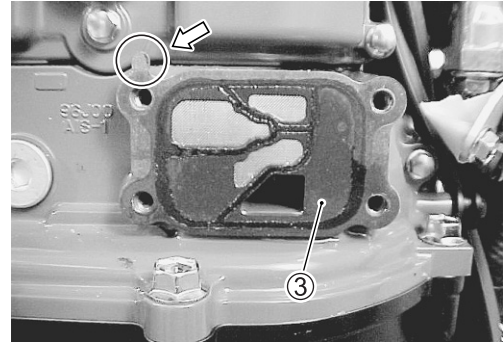

**FINAL ASSEMBLY CHECK**

- All parts removed have been returned to their original positions.
- Wire and hose routing match's service manual illustration.
- No oil leakage is evident during final test running.

## POWER UNIT REMOVAL

### Before removing power unit;

- Relieve fuel pressure. (See page 5-3.)
- Drain engine oil.
- Disconnect battery cables from battery.

Remove the fuel vapor separator ①. (See page 5-7.)

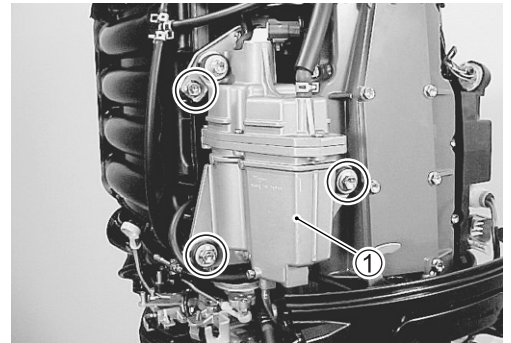

Remove the fuel injectors and intake manifold assembly ②.  
(See page 6-3 to 6-5.)



Disconnect ignition coil connectors ③.  
Remove bolts securing the ignition coils ④.  
Remove all ignition coils ④ and spark plugs.

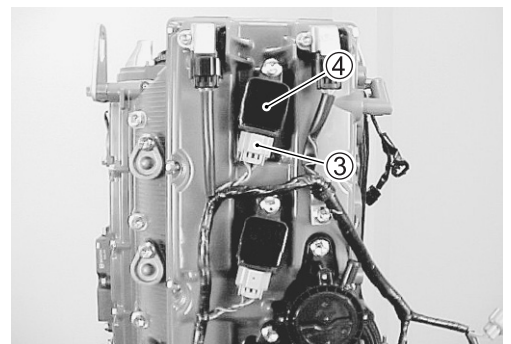

Remove the cylinder head cover ⑤. (See page 6-11 to 6-12.)

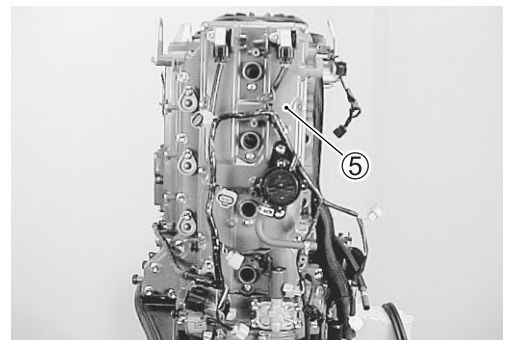

Remove the electric parts holder ⑥. (See page 4-30.)

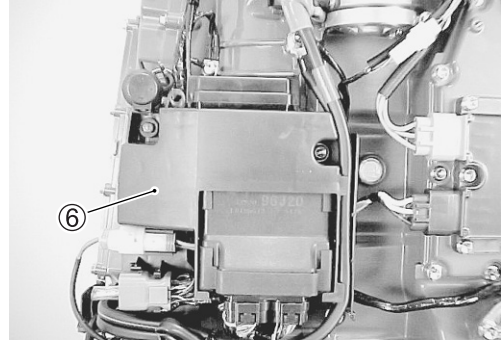

Remove starter motor ⑦. (See page 4-17.)

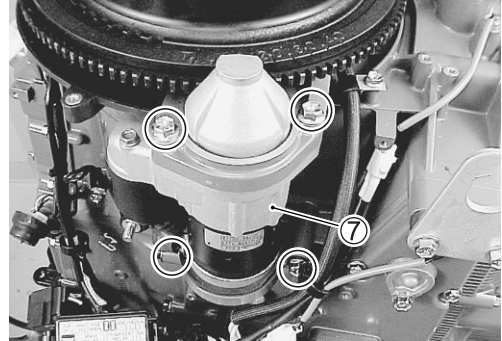

Remove flywheel ⑧. (See page 3-66.)

**TOOL** 09916-99311: Flywheel holder

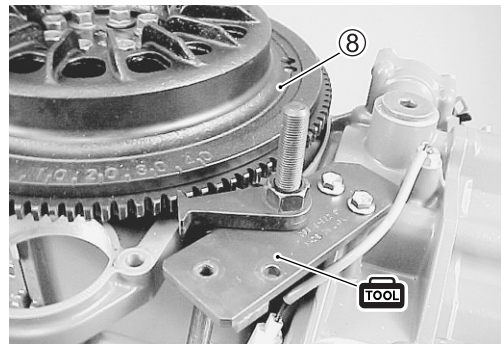

Remove battery charge coil ⑨. (See page 4-9.)

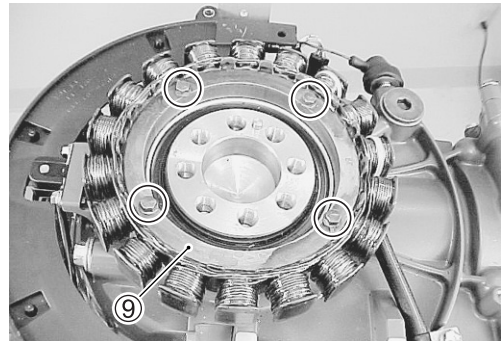

Disconnect charge output lead wire connector from Rectifier & regulator.

Remove six bolts and Rectifier & regulator ⑩.

Remove the bolt securing lead wire clamp plate ⑪.

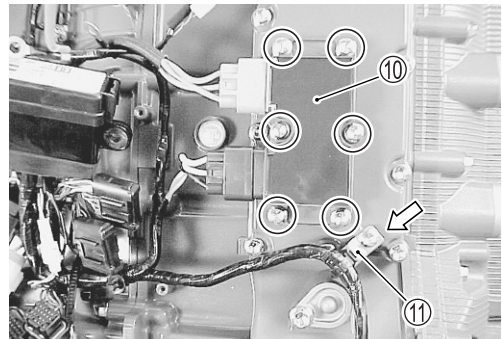



Disconnect EX. manifold temperature sensor lead wire connector.

Remove EX. manifold temperature sensor ⑫.

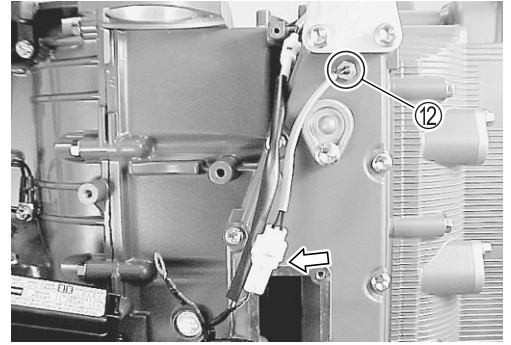

Disconnect cylinder temperature sensor lead wire connector.

Remove cylinder temperature sensor ⑬.

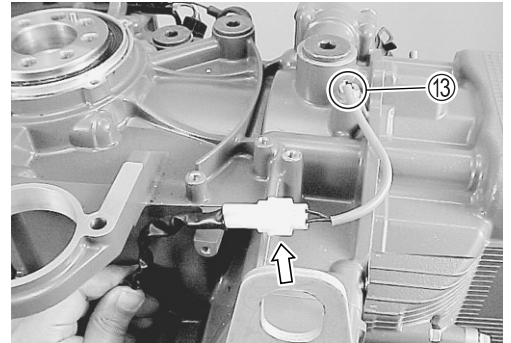

Remove screws and CKP sensor ⑭.

Disconnect CKP sensor lead wire connector.



Loosen screw and disconnect blue lead wire ⑮ from oil pressure switch ⑯.

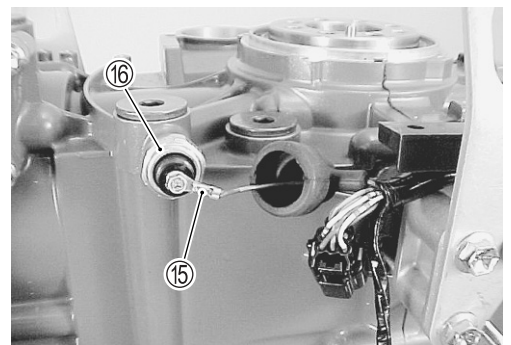

Remove the two bolts securing lower ring gear cover ⑰, then remove ring gear cover with wiring harness.

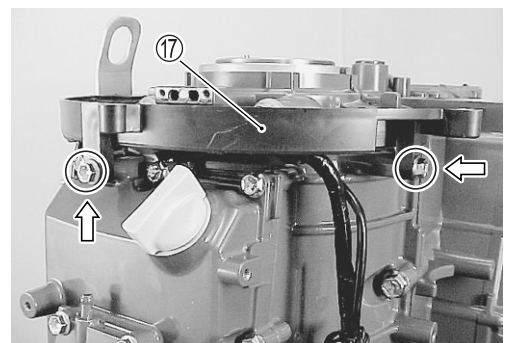

Remove the bolt securing GND lead wire terminals.

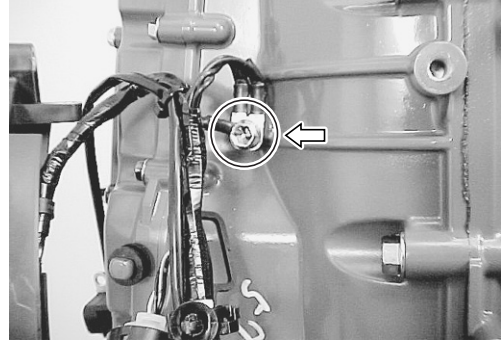

Remove the screws securing hose and harness holder ①.  
Disconnect water inlet hose ② from balancer water jacket cover ③.

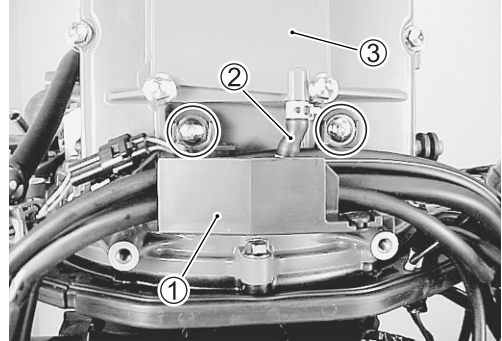

Disconnect shift position sensor lead wire connector ④.  
Disconnect neutral switch lead wire connector ⑤.

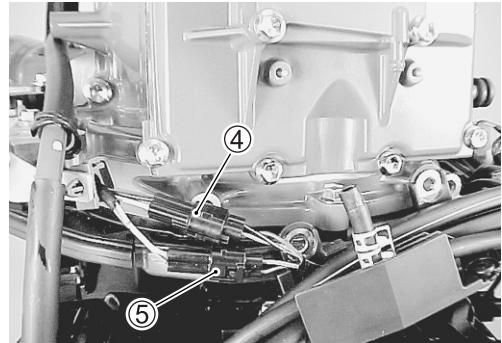

Remove three (3) bolts, thermostat cover ⑥ and thermostat ⑦.

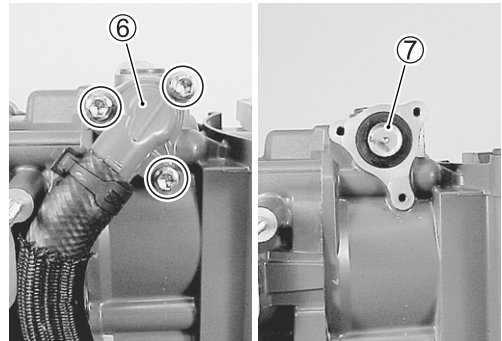

Disconnect pilot water hose ⑧ from cylinder block.  
Disconnect water inlet hose ⑨ from cylinder block.

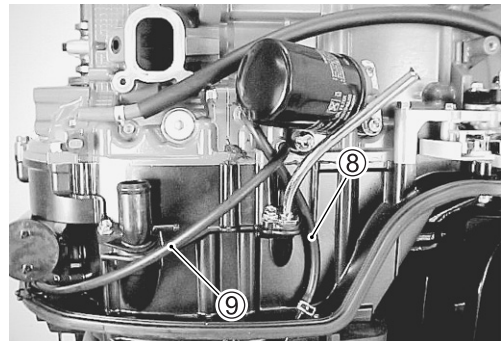

Remove oil level dipstick ⑩.

Remove bolt and oil dipstick tube ⑪.

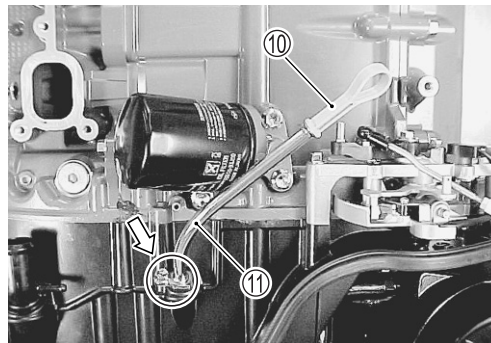

Remove water flush hose ⑫ from cylinder block.

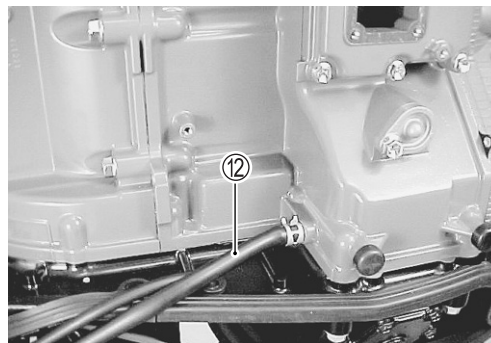

**[From engine upper side]**

- Remove five (5) bolts ①.

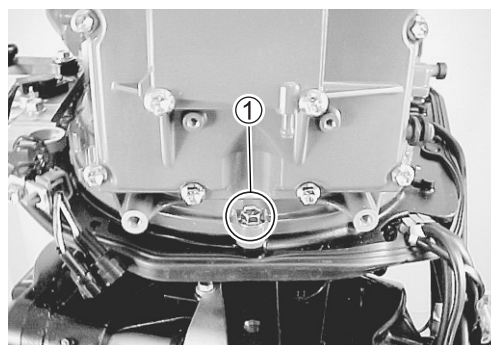
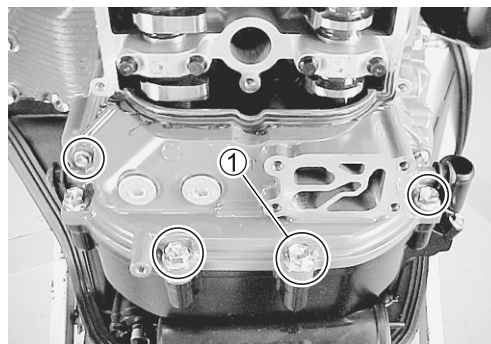

**[From engine under side]**

- Remove sixteen (16) bolts ②.

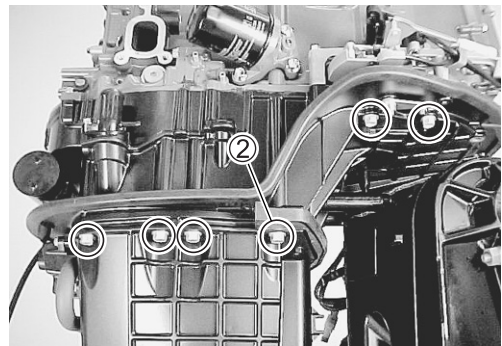
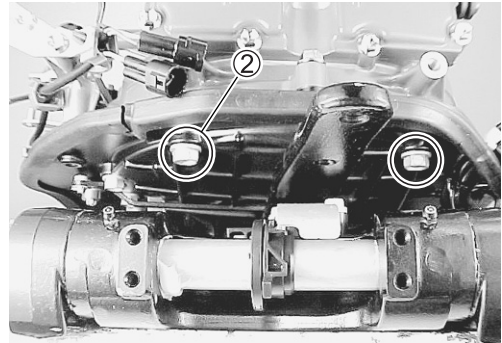
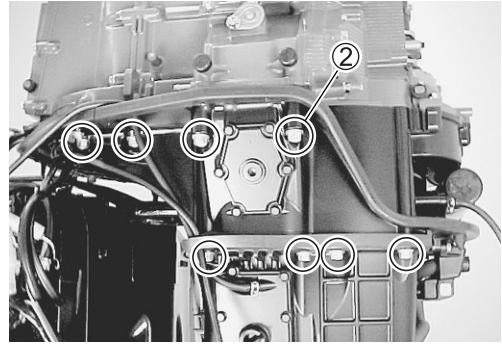

Lift up and remove power unit from engine holder.



## INSTALLATION

Installation is reverse order of removal with special attention to the following step.

### CAUTION

**Do not reuse gaskets, O-rings and seals.  
Always replace with new parts.**

### POWER UNIT

- Install dowel pins ①, gasket ②.  
Apply Water Resistant Grease to driveshaft splines.

 **99000-25160: SUZUKI WATER RESISTANT GREASE**

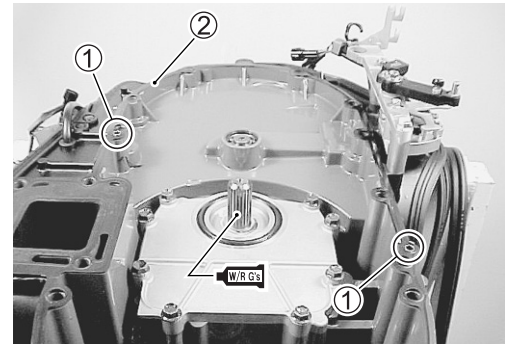

- Install O-ring ③ to mount oil seal cover, then apply Water Resistant Grease on O-ring.
- Install the engine holder seal ④.

### NOTE:

*Install seal ④ with lip facing upward.*

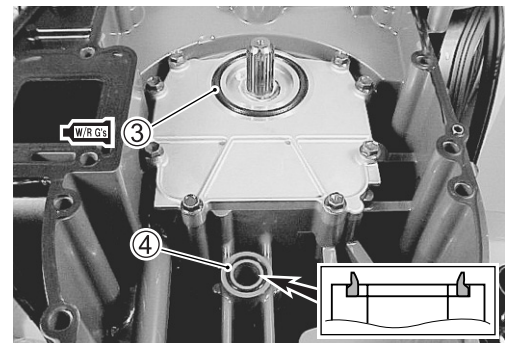

### NOTE:

*Before installing power unit, apply sealant to the six hatched areas shown in the illustration at right.*

 **99000-31140: SUZUKI BOND "1207B"**

- Lower the power unit onto engine holder.

### NOTE:

*Rotate crankshaft to aid alignment of driveshaft and counter shaft splines.*

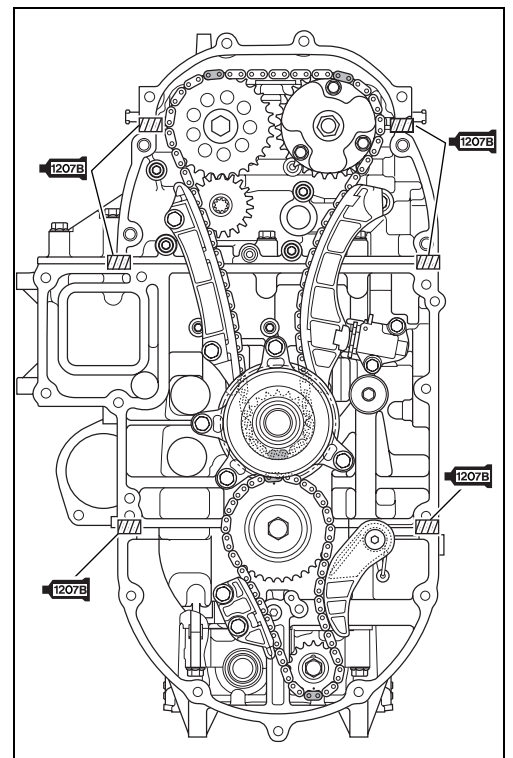

- Apply Suzuki Silicone seal to power unit mounting bolts and tighten bolts to specified torque.

 **99000-31120: SUZUKI SILICONE SEAL**

 **Power unit mounting bolt:**

8 mm 23 N·m (2.3 kg-m, 16.5 lb-ft)

10 mm 50 N·m (5.0 kg-m, 36.0 lb-ft)

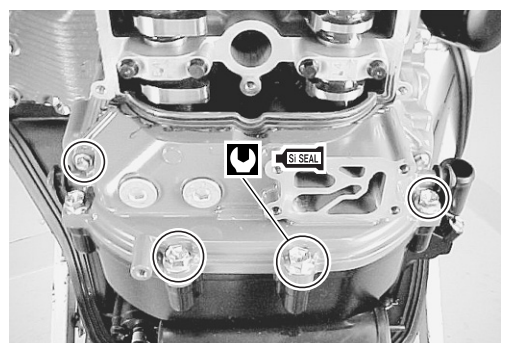
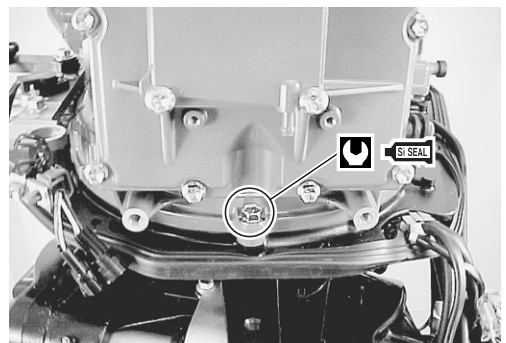
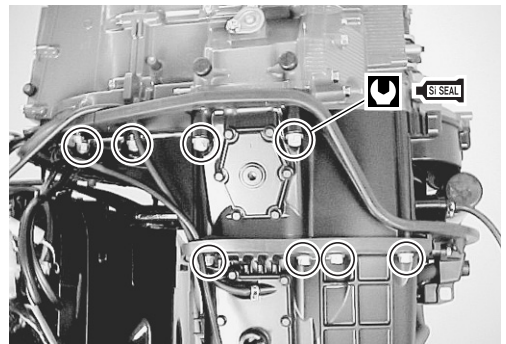
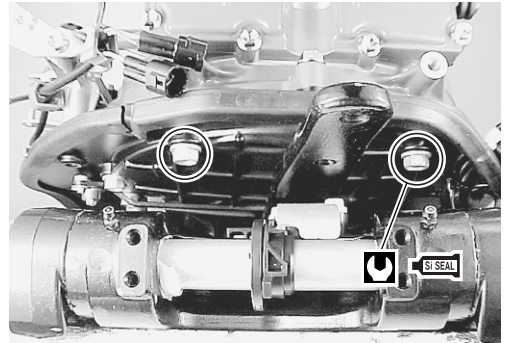
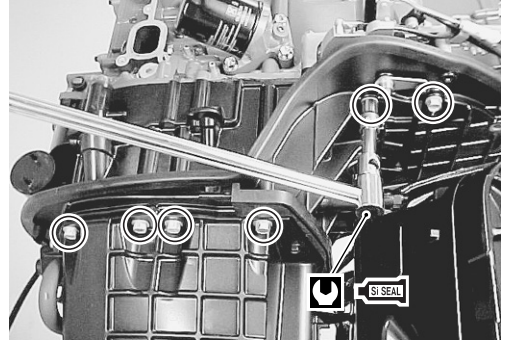

**THERMOSTAT**

- Assemble thermostat ① and thermostat cover ② to cylinder block and secure with bolts.

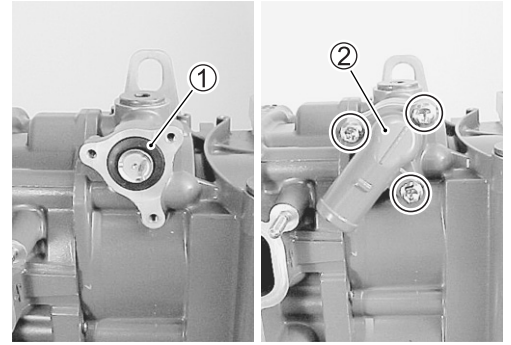

- Connect water return hose ③, then secure the hose to thermostat cover with hose clamp.

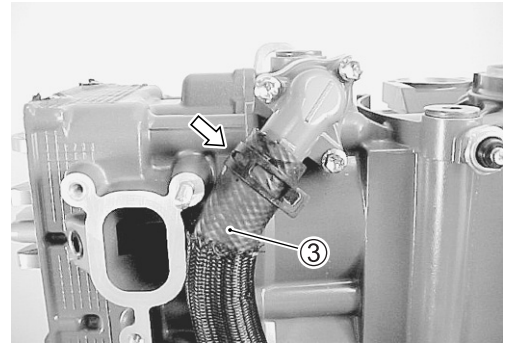
**FLYWHEEL**

- Install lower ring gear cover ①, then tighten bolts securely.
- Install CKP sensor ②. (See page 3-68.)

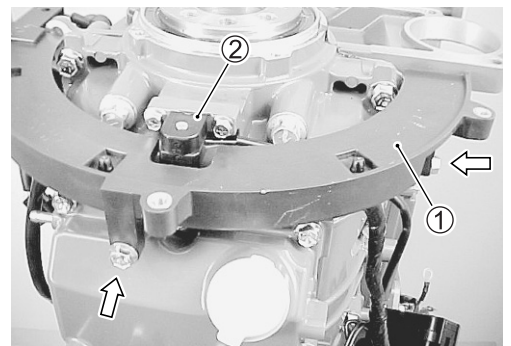

- Install battery charge coil ③. (See page 4-10.)

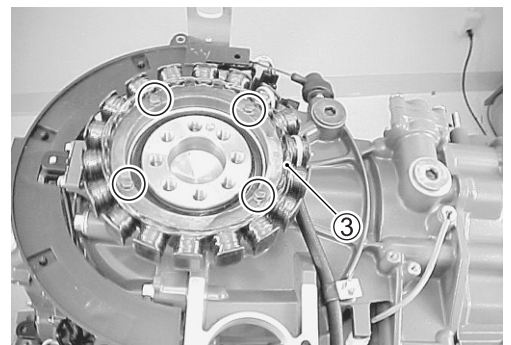

- Install flywheel and tighten flywheel bolts to specified torque. (See page 3-67.)

**TOOL** 09916-99311: Flywheel holder

**TOOL** Flywheel bolt: 118 N·m (11.8 kg·m, 85.3 lb-ft)

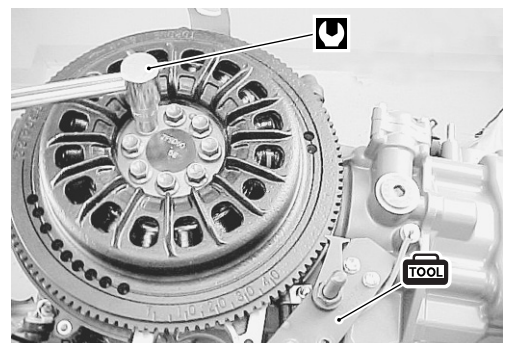

### CYLINDER HEAD COVER

- Install cylinder head cover. (See page 6-13.)

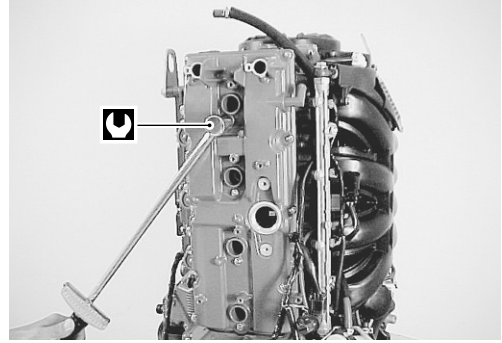

### INTAKE MANIFOLD

- Install gaskets and intake manifold, then tighten bolts and nuts to specified torque.  
For intake manifold assembly installation, see page 6-5.

 Intake manifold bolt/nut: 23 N·m (2.3 kg-m, 16.5 lb-ft)



### FUEL INJECTORS

- Install fuel injectors and fuel delivery pipe. (See page 5-15.)

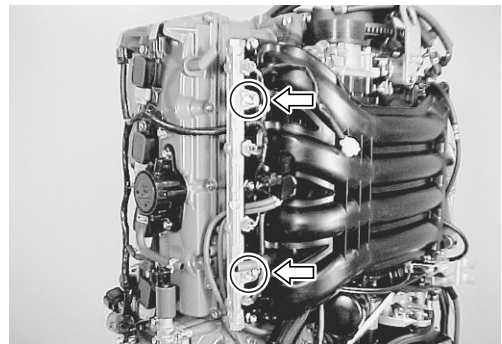

### VAPOR SEPARATOR

- Install vapor separator. (See page 5-8.)

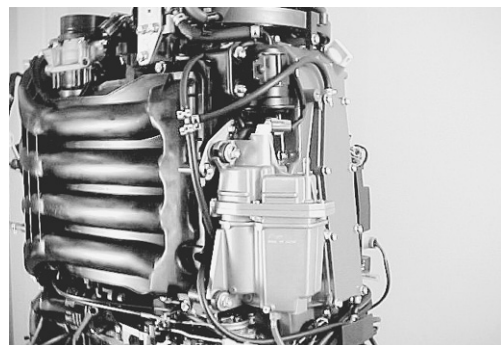



**FINAL ASSEMBLY CHECK**

Perform the following checks to ensure proper and safe operation of the repaired unit.

- All parts removed have been returned to their original positions.
- Fuel and water hose routing match's service manual illustration. (See page 11-11 to 11-17.)
- Wire routing match's service manual illustration. (See page 11-4 to 11-10.)
- No fuel leakage is evident when fuel system is pressurized. (See page 5-4.)
- No water leakage is evident during final test running.

## OIL PUMP REMOVAL

1. Remove the power unit. (See page 6-15 to 6-20.)
2. Remove the four (4) bolts securing oil pump ①, then remove the oil pump.  
Account for shim washer ②.

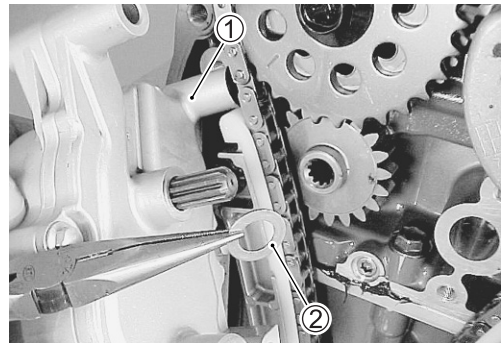
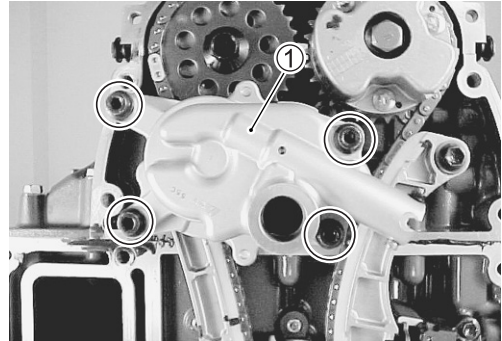

3. Remove the oil pump driven gear ③.

**NOTE:**

*For oil pump drive gear removal, see page 6-31.*

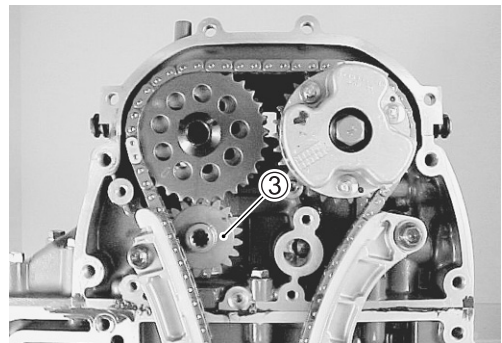

## DISASSEMBLY

1. Remove the two (2) screws ① securing oil pump rotor plate ② to the oil pump case, then remove the oil pump rotor plate.

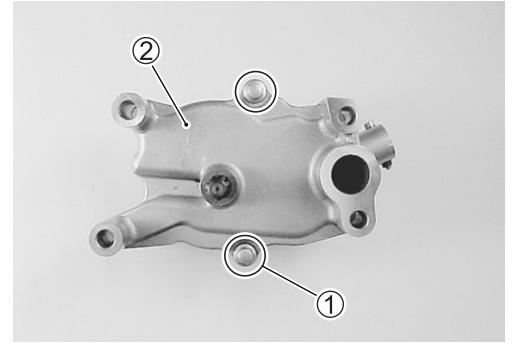

2. Take out inner rotor ③ and outer rotor ④.

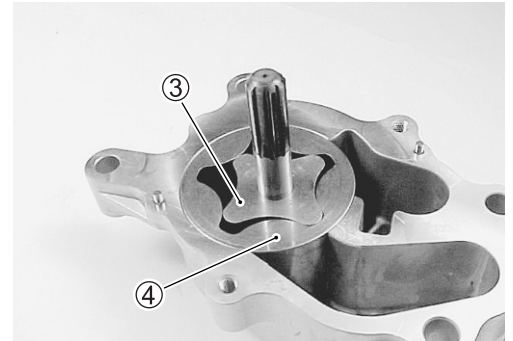

3. Remove the pin ⑤ and inner rotor ③.

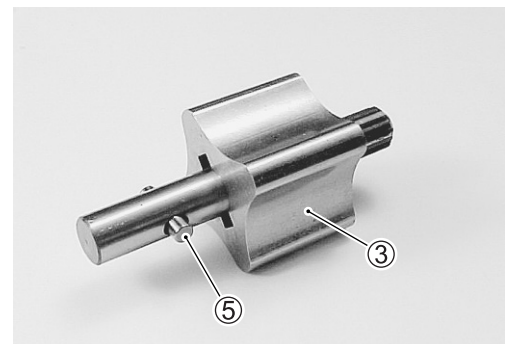

## INSPECTION

### OIL PUMP ASSEMBLY

Check outer and inner rotors, rotor plate and oil pump case for excessive wear or damage.

Replace as necessary.

#### NOTE:

*If any repair is required on outer rotor, inner rotor and oil pump case/plate, replace them as an assembly.*

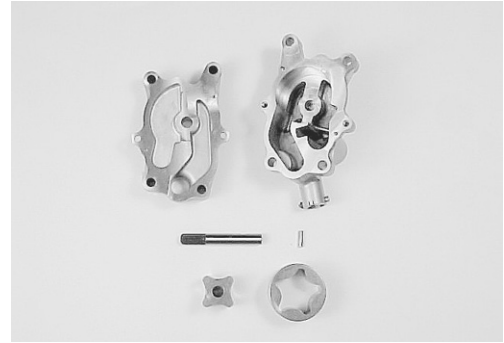

### DRIVEN SPROCKET

Check teeth of sprocket for wear or damage.

Replace as necessary.



## MEASURING PUMP COMPONENTS

### RADIAL CLEARANCE

Using a feeler gauge, measure radial clearance between outer rotor and case.

#### Radial clearance:

**Service limit: 0.31 mm (0.0122 in)**

If measurement is not within specifications, replace the outer rotor and/or case.

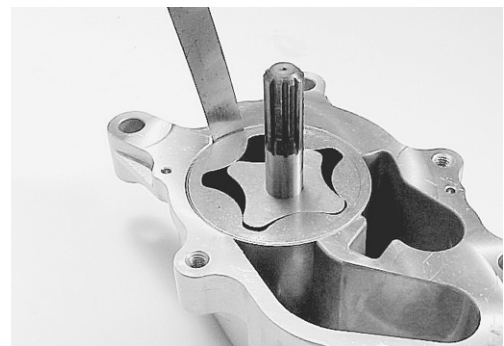

### SIDE CLEARANCE

Using straightedge and feeler gauge, measure side clearance.

#### Side clearance:

**Service limit: 0.15 mm (0.0059 in)**

If measurement is not within specifications, replace the outer rotor and/or pump case.

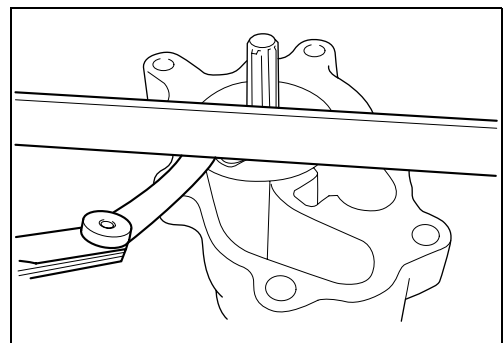



## ASSEMBLY

1. Wash, clean and then dry all disassembled parts.
2. Apply thin coat of engine oil to inner and outer rotors, inside surfaces of oil pump case and plate.
3. Assemble pin ① and inner rotor ② to oil pump shaft.

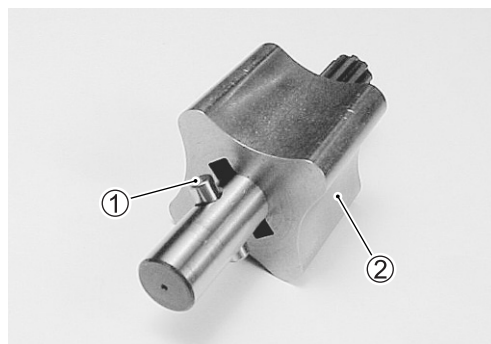

4. Install outer ③ and inner rotor ② to pump case.

**NOTE:**

*When installing outer and inner rotors, the punch mark on each rotor must face rotor plate.*

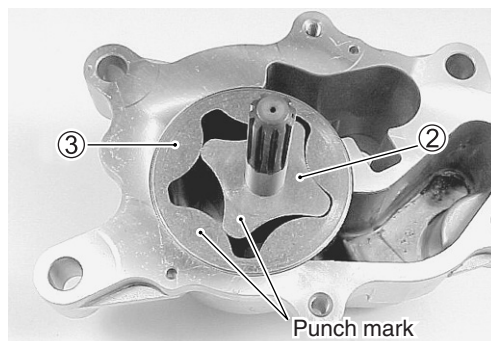

5. Install dowel pins ④ and rotor plate ⑤, and then tighten screws ⑥ securely.  
After mounting the rotor plate, make sure that each rotor turns smoothly by hand.
6. Pour approx. 50 ml (1.7 oz.) of engine oil into pump case for initial lubrication.

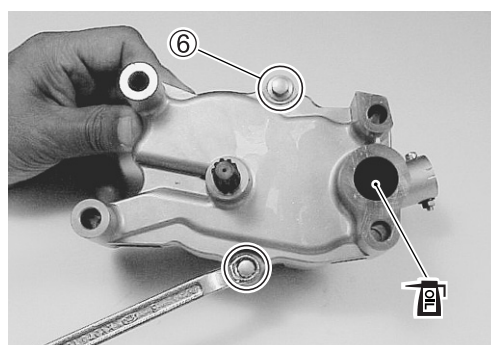
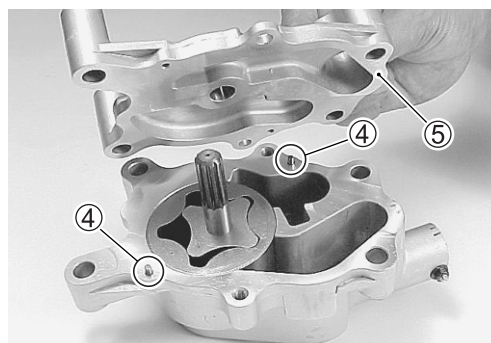

## INSTALLATION

Installation is reverse order of removal with special attention to following steps.

- Install oil pump driven gear ①.

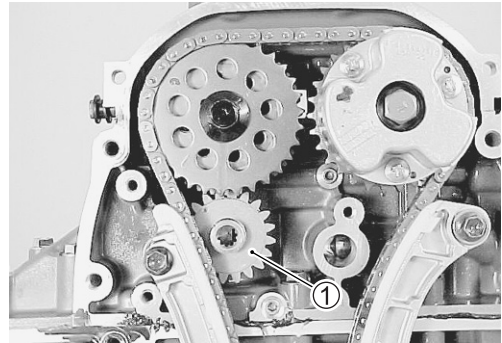
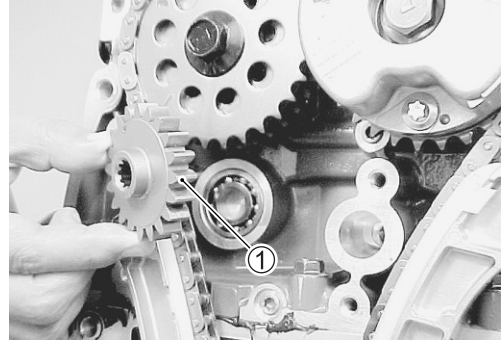

- Install washer ② and oil pump assembly ③, then tighten four (4) bolts securely.

**🔩 Oil pump bolt: 23 N·m (2.3 kg-m, 16.5 lb-ft)**

- Pour approx. 50 ml (1.7 oz.) of engine oil into pump case for initial lubrication.

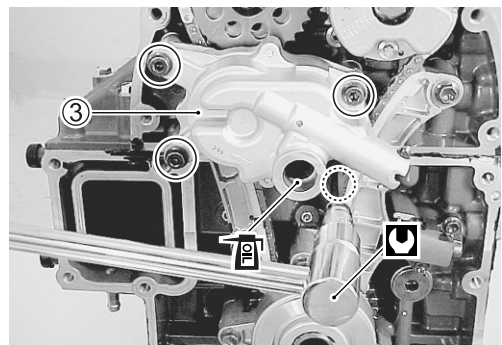
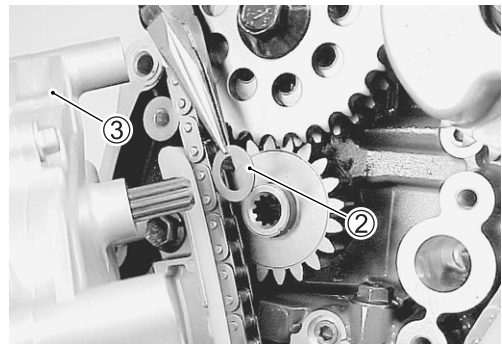

## TIMING CHAIN/BALANCER CHAIN (VVT model) REMOVAL

### Prior to this service work:

- Remove the power unit. (See page 6-15 to 6-20.)

1. Crankshaft/Drive gear/Balancer drive gear
2. Driven gear/Timing sprocket
3. Driven gear holder
4. Chain tensioner adjuster
5. Timing chain tensioner
6. Timing chain guide
7. Timing chain
8. IN. camshaft timing sprocket
9. EX. camshaft timing sprocket
10. Balancer driven sprocket
11. Balancer chain tensioner
12. Balancer chain guide
13. Balancer chain

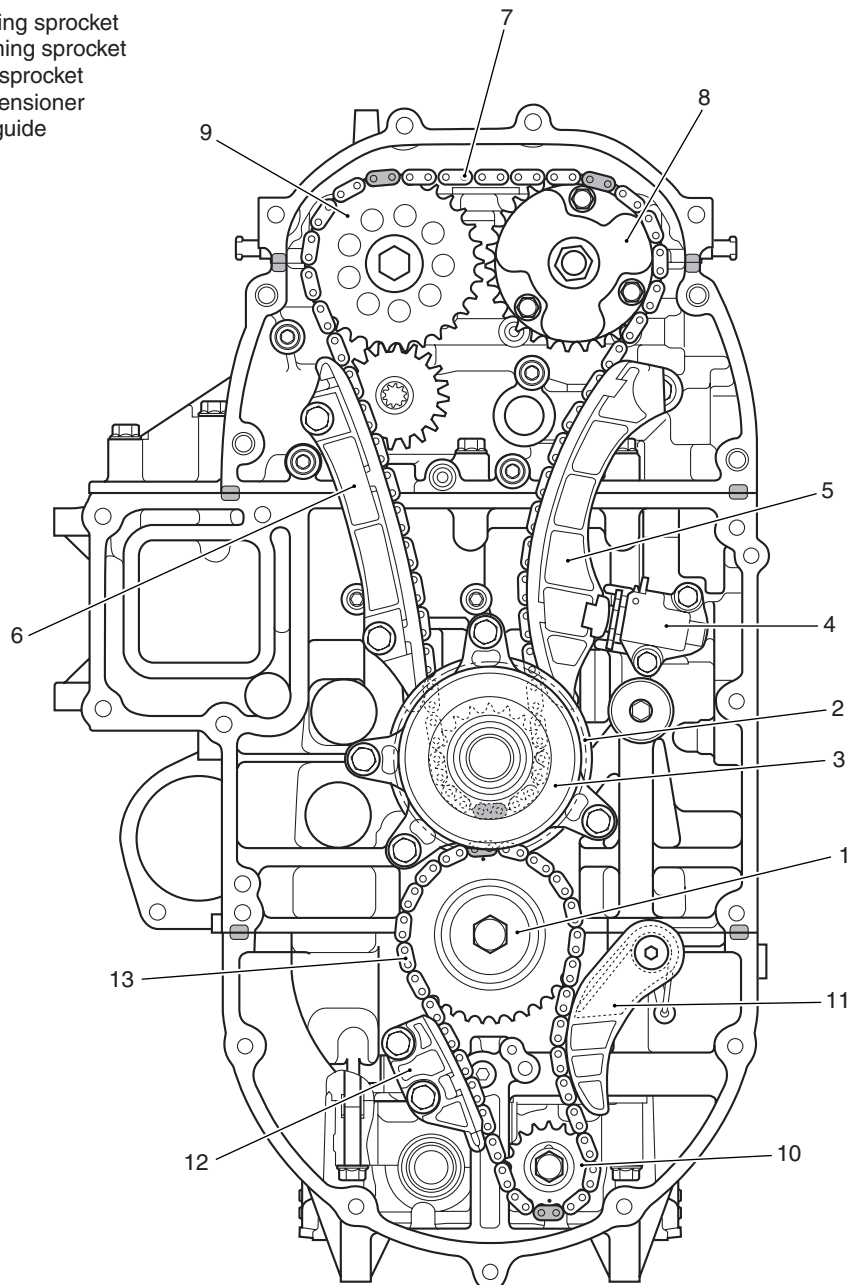

1. Remove the oil pump. (See page 6-26.)
2. Loosen the bolts securing IN./EX. camshaft timing sprockets to each cam shaft.

**NOTE:**

- Sprocket bolt is LH thread.
- Hold camshaft by placing a wrench on the hexagon area of the camshaft.

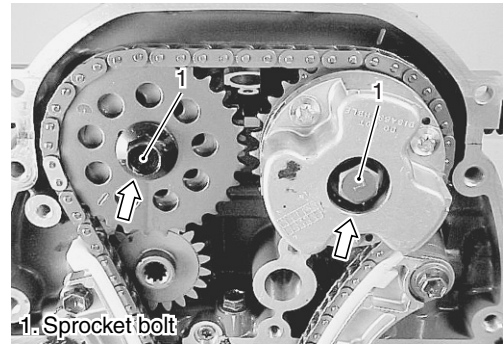

3. Remove the four (4) bolts ① securing driven gear holder ②, then remove the driven gear holder.

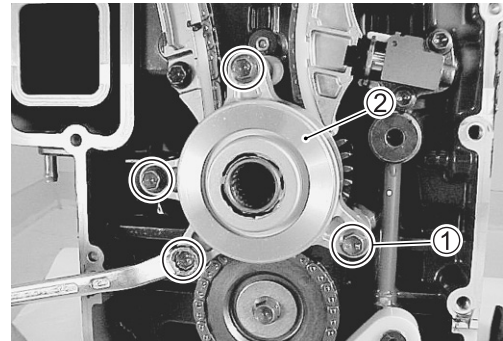

4. Remove bolts ③ and balancer chain guide ④.

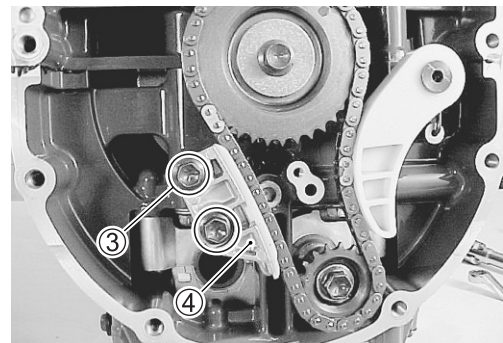

5. Remove bolt ⑤, balancer chain tensioner ⑥ and spring ⑦.

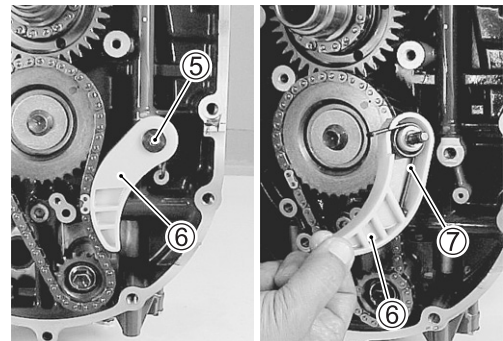



6. Loosen and remove the bolt ⑧ securing balancer drive sprocket ⑨ to crankshaft.

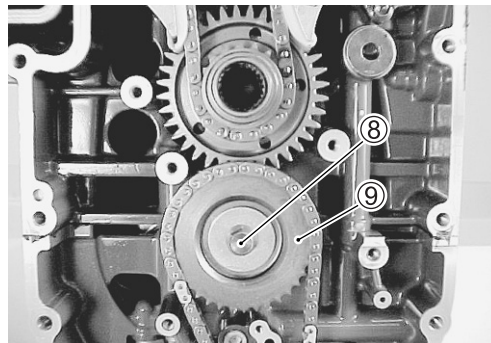

**NOTE:**

To hold the crankshaft, use special tool and flywheel as shown in figure.

 09916-99311: Flywheel holder

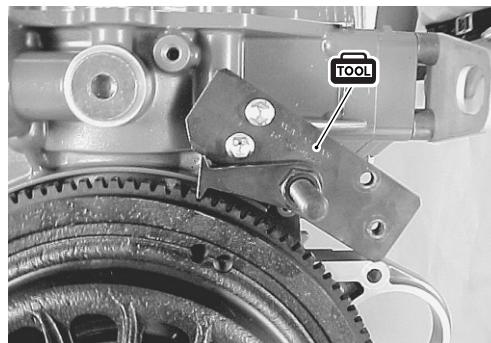

7. Remove the balancer drive sprocket ⑨ and balancer chain ⑩.

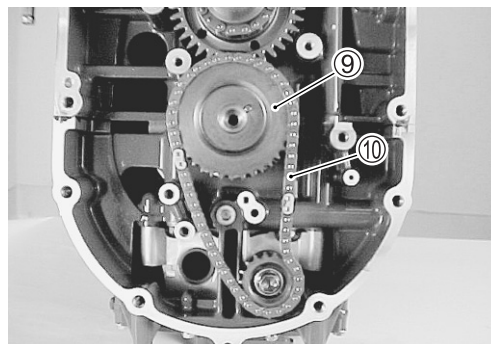

8. Turn the crankshaft in its normal running direction (Ⓜ\_LH direction) until the match mark (•) on the crankshaft drive gear points to 12 o'clock (toward cylinder head).

**CAUTION**

When timing chain has been removed, never turn crankshaft or camshaft.

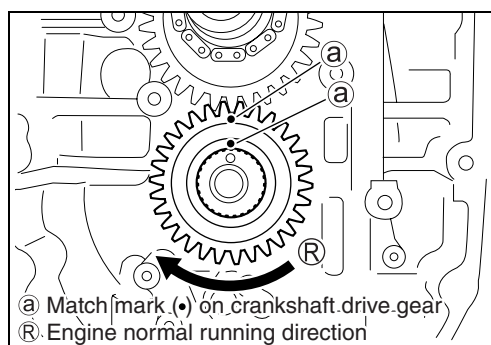

9. Remove bolts ⑪ and timing chain guide ⑫.

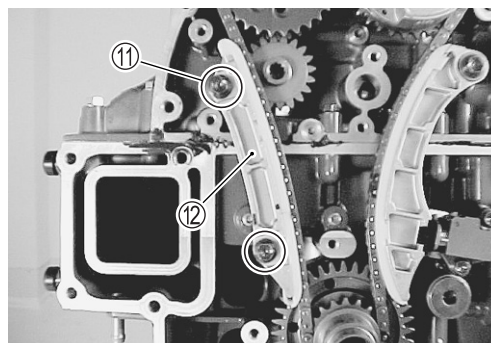

10. Remove bolts ⑬ and chain tensioner adjuster ⑭.

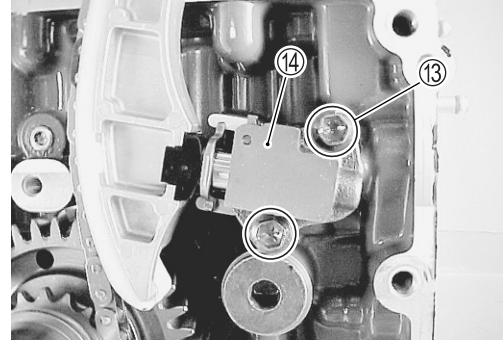

11. Remove bolt ⑮ and timing chain tensioner ⑯.

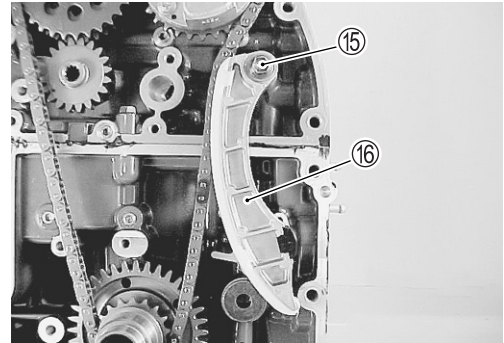

12. Remove bolt ⑰, EX. camshaft timing sprocket ⑱ and timing chain ⑲.  
Remove oil pump drive gear ⑳.

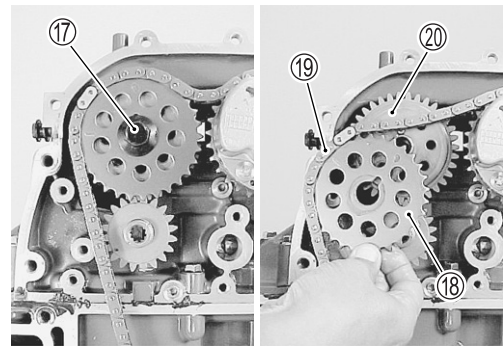

13. Remove bolt ㉑ and IN. camshaft timing sprocket ㉒.

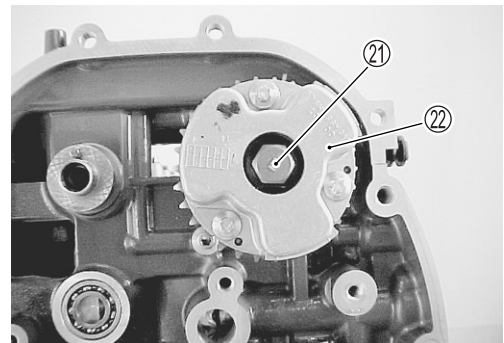

14. Remove driven gear ㉓.

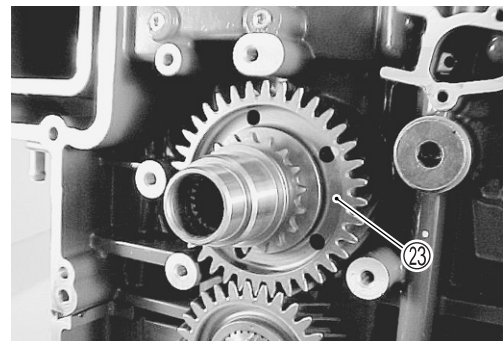

15. Remove drive gear ⑳.

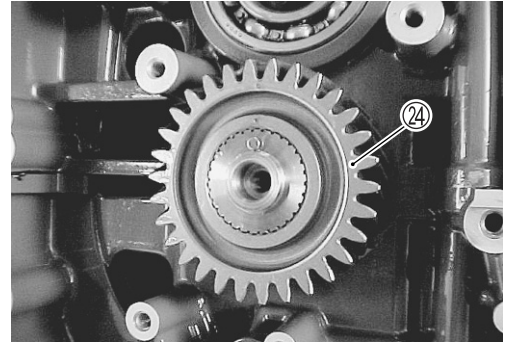

## INSPECTION

### NOTE:

*If any component is worn excessively, cracked, defective or damaged in any way, it must be replaced.*

### TIMING CHAIN

- Inspect timing chain.  
Replace if worn excessively or damaged.

### BALANCER CHAIN

- Inspect balancer chain.  
Replace if worn excessively or damaged.

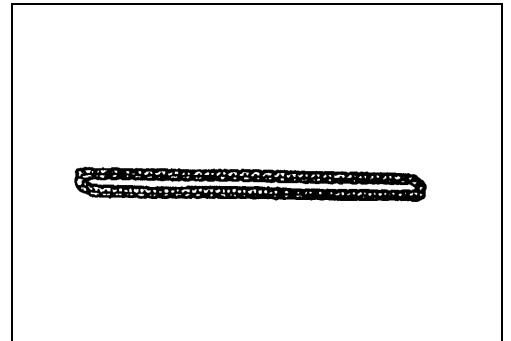

### TENSIONER ADJUSTER

- Inspect tensioner adjuster for smooth operation.  
Replace if faulty.  
Check oil delivery passage to tensioner.

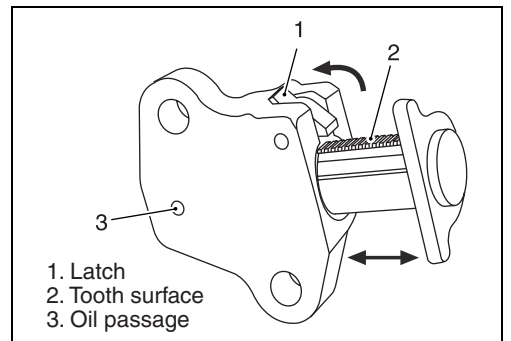

### TIMING CHAIN TENSIONER/CHAIN GUIDE

- Check chain guide shoe for wear or damage.  
If excessive wear or other damage is found, replace it.



**CAMSHAFT TIMING SPROCKET**

- Check teeth of sprocket for wear or damage.

**CAUTION**

**The VVT actuator is non-repairable.  
Do not attempt to remove bolts or disassemble the  
VVT actuator.**

If excessive wear or other damage is found, replace it.

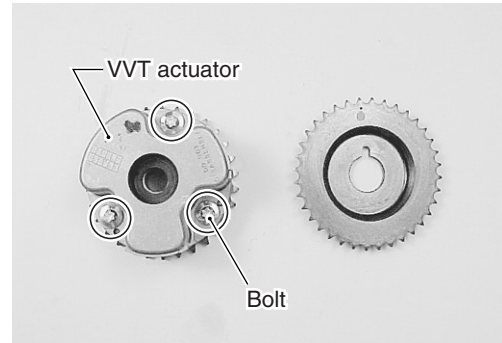
**DRIVEN GEAR HOLDER**

- Check driven gear holder.
  - If cracks or other damage is found, replace holder.
- Check driven gear bearing.
  - Replace bearing if pitted, noisy, or rough condition.
- Check oil seal.
  - If excessive wear or other damage is found, replace oil seal.

**NOTE:**

Install oil seal lip (spring side) facing as shown in figure.

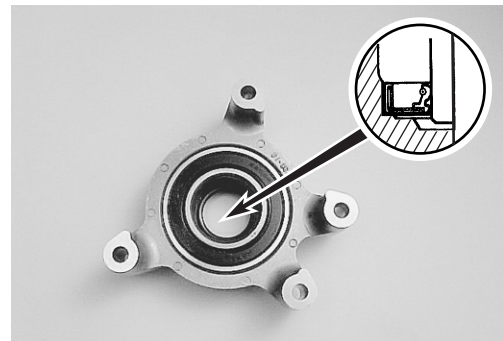
**DRIVE GEAR/DRIVEN GEAR/BEARING**

- Inspect drive and driven gears.
  - Replace gear if damaged or worn excessively.
- Check driven gear bearing.
  - Replace bearing if pitted, noisy, or rough condition.

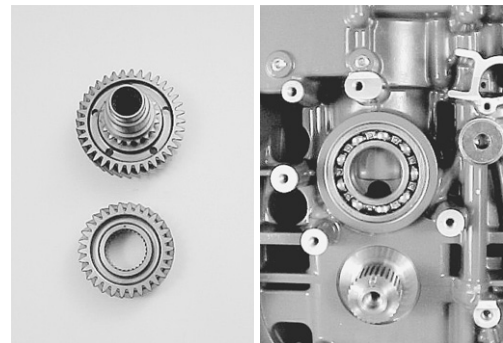
**BALANCER SPROCKET**

- Check teeth of sprocket for wear or damage.
  - If excessive wear or other damage is found, replace it.

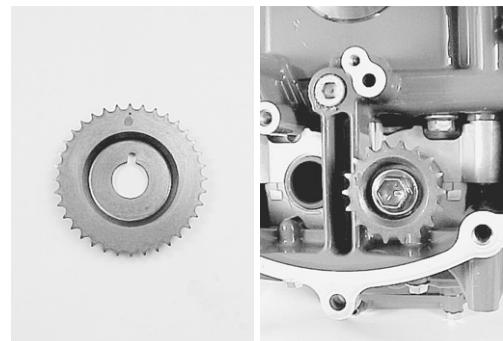



### BALANCER CHAIN TENSIONER/CHAIN GUIDE

- Check tensioner for wear or damage.  
If excessive wear or other damage is found, replace it.
- Check chain guide for wear or damage.  
If excessive wear or other damage is found, replace it.



### OIL PUMP DRIVE GEAR

- Inspect drive gear.  
Replace gear if damaged or worn.



## INSTALLATION

Installation is reverse of removal with special attention to following steps.

1. Install the drive gear ① on crankshaft so that dowel pin hole ② aligns with match mark (•) ③ on the drive gear as shown in illustration.
2. Check that match mark (•) ④ on the crankshaft drive gear points to 12 o'clock (towards cylinder head).
3. Install the driven gear ⑤ on the cylinder block so that match mark (•) ⑥ aligns with match mark (•) ⑦ on the driven gear as shown in illustration.

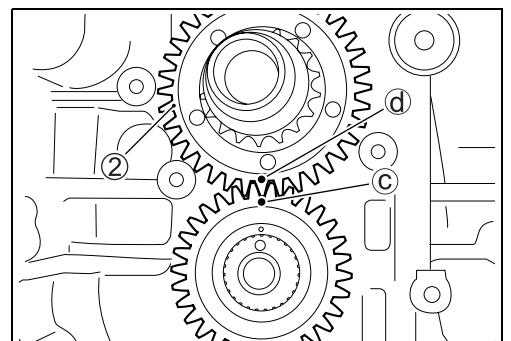
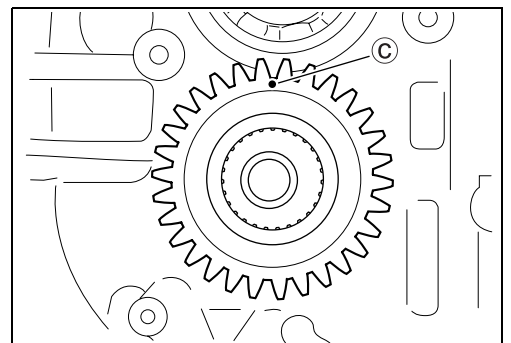
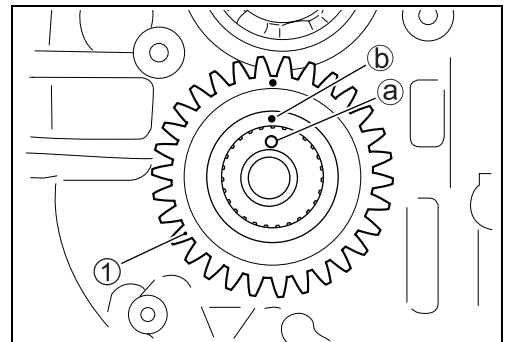



4. Fit the dowel pin ③ onto IN. camshaft. Fit IN. camshaft timing sprocket ④ and temporarily tighten the sprocket bolt. Check that match marks (•) ⑤-⑥ are correctly aligned as shown in illustration.

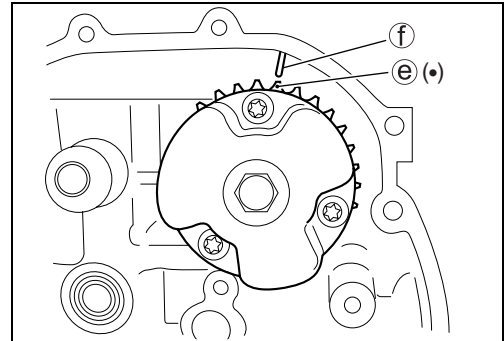
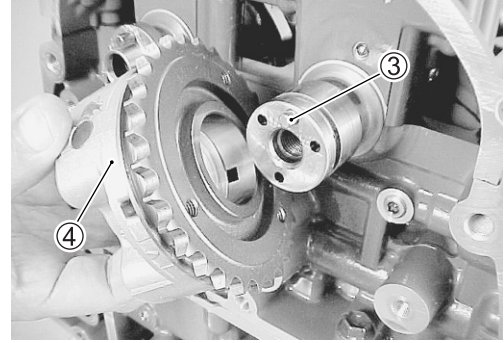

5. Fit the dowel pin ⑤ onto the EX. camshaft.  
6. Install oil pump drive gear ⑥.

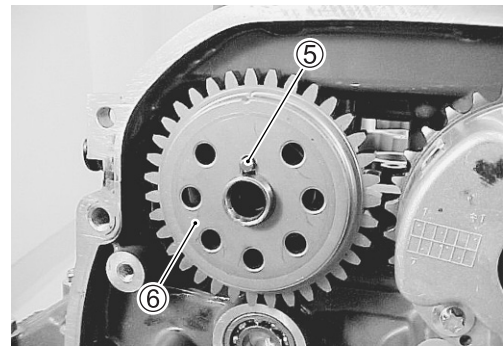

7. Align the yellow plate of timing chain ⑦ with the match mark (•) ① on the driven gear and fit the chain onto the driven gear.

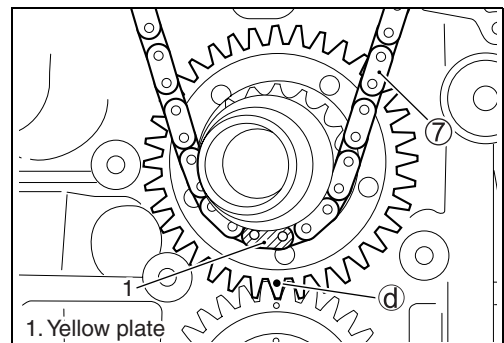

8. As shown in the illustration, fit the timing chain with one blue plate aligned with the match mark (Δ) (•) ② onto the IN. camshaft timing sprocket.

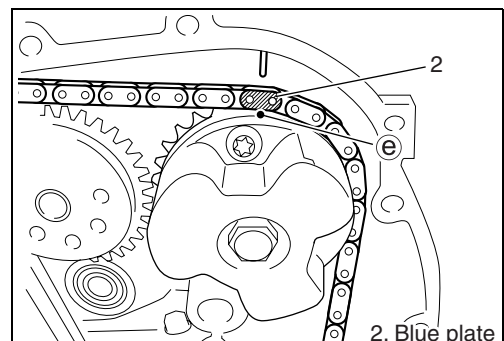

9. While aligning the one blue plate of timing chain with the match mark (•) ⑨ on the EX. camshaft timing sprocket ⑧, fit the chain onto the sprocket.

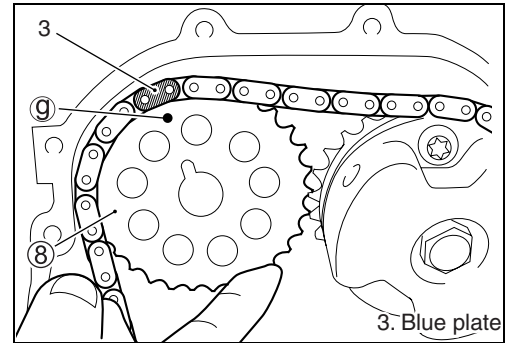

10. Install the EX. camshaft timing sprocket ⑧ on the EX. camshaft, then temporarily tighten the sprocket bolt.

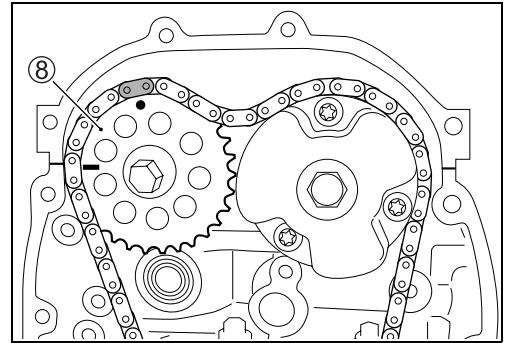

11. Insert the spacer ⑨ into the chain tensioner ⑩. Install chain tensioner, then tighten bolt ⑪ securely. Apply engine oil to chain tensioner.

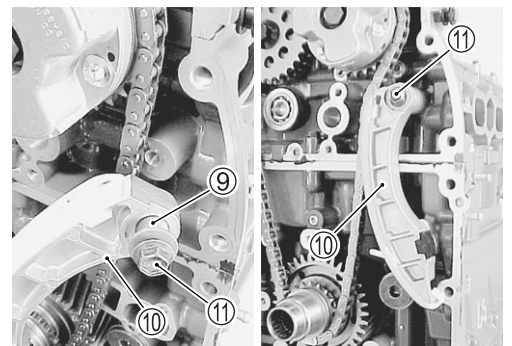

12. With latch of tensioner adjuster ⑫ pushed in and plunger pushed back into body, insert stopper into latch and body. After inserting stopper, check to make sure that plunger will not come out.

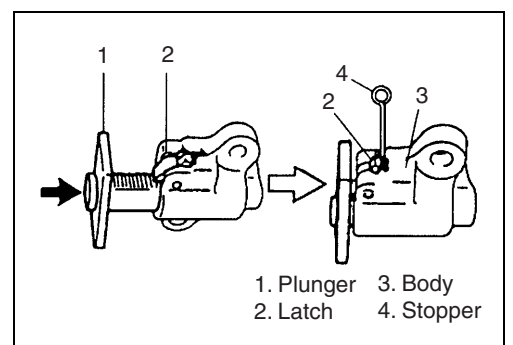

13. Install timing chain tensioner adjuster ⑫, then tighten bolts ⑬ to specified torque.

**🔧 Tensioner adjuster bolt: 11 N·m (1.1 kg·m, 8.0 lb·ft)**

Apply engine oil to timing chain.

14. Remove the stopper from tensioner adjuster.

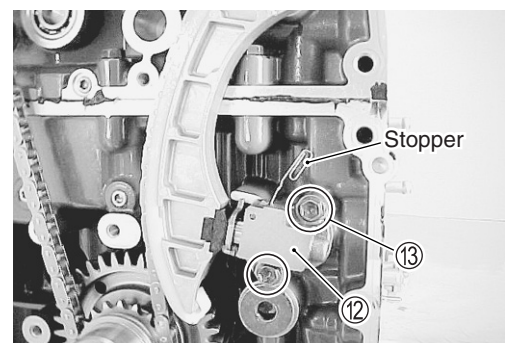

15. Install timing chain guide ⑭, then tighten bolts securely.  
Apply engine oil to chain guide.

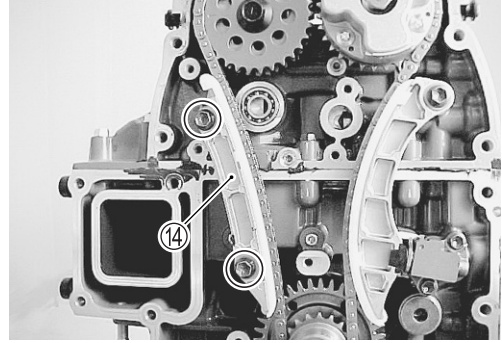

16. Turn the crankshaft two (2) complete rotations in direction shown in figure.

As shown in the illustration, check that all match marks are in alignment as started below when the match mark (•) © on the drive gear is pointing to 12 o'clock.

- The match mark (△) (•) © on the IN. sprocket aligns with the match mark ƒ on the camshaft housing.
- The match mark (engraved line) ƒ on the EX. sprocket aligns with the mating face ① between cylinder head and lower camshaft housing.

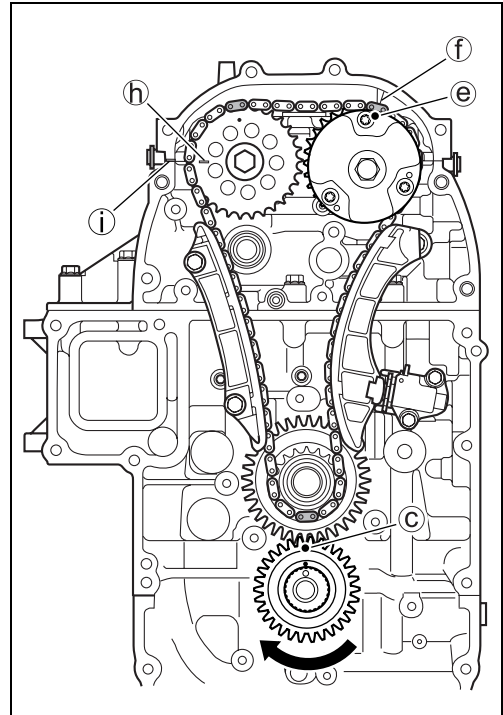

17. Check that match mark (•) © on the crankshaft drive gear points to 12 o'clock (towards cylinder head).

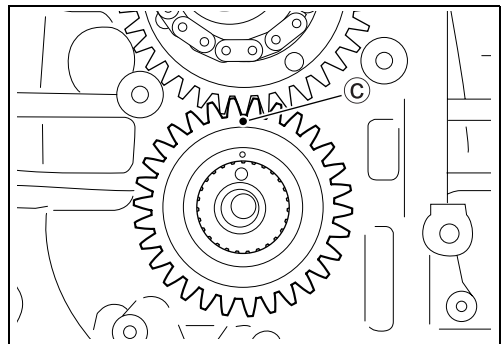

18. Check that match mark (•) ① on the balancer driven sprocket points to 6 o'clock as shown in the illustration.

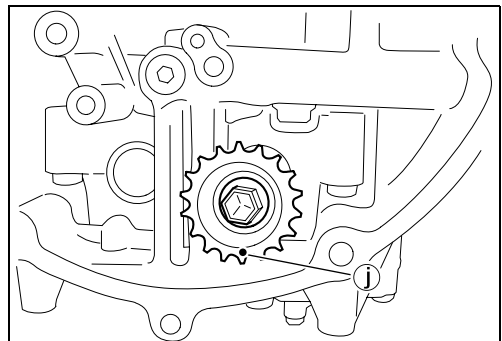

19. Fit the dowel pin ⑮ on the crankshaft.

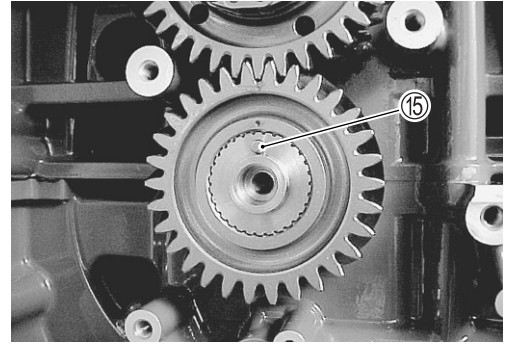

20. Align the yellow plate of balancer chain ⑯ with the match mark (•) ⑰ on the balancer driven sprocket and fit the chain on the sprocket.

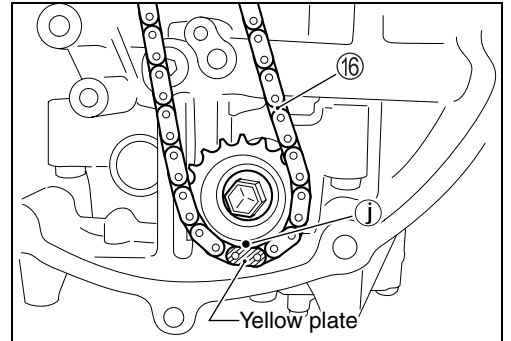

21. Align the yellow plate of balancer chain with the match mark (•) ⑱ on the balancer drive sprocket ⑳ and fit the chain on the sprocket.

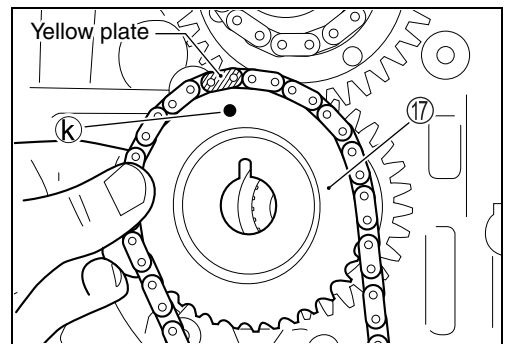

22. Install the balancer drive sprocket ⑳ on the crankshaft, then temporarily tighten the sprocket bolt and washer. Check that match marks ⑰ and ⑱ are correctly aligned as shown in illustration.

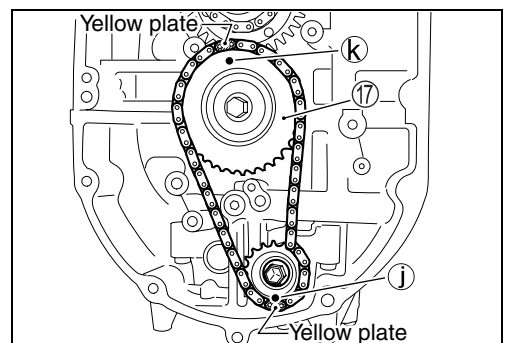

23. Install balancer chain guide ㉑, then tighten bolts ㉒ securely.

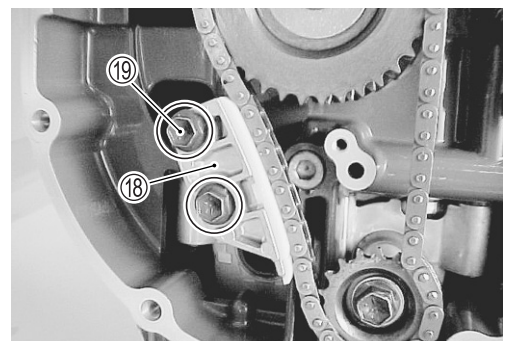



24. Assemble tensioner spring ⑳ and balancer chain tensioner ㉑.

Install chain tensioner ㉑, then tighten bolt ㉒ securely.

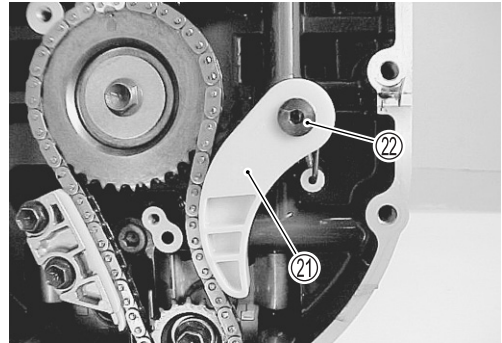
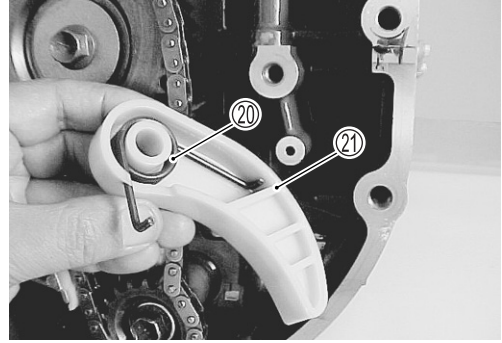

25. Tighten crankshaft drive gear bolt ㉓ to specified torque.

 Crankshaft drive gear bolt: 48 N·m (4.8 kg-m, 34.7 lb-ft)

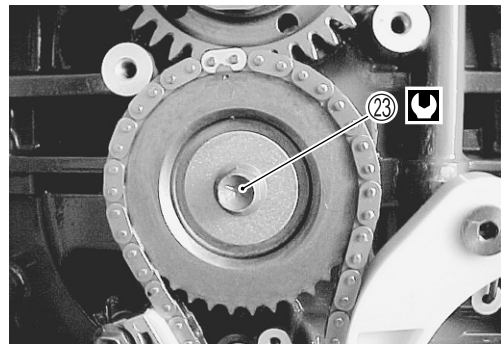

**NOTE:**

To hold the crankshaft, use special tool and flywheel as shown in figure.

 09916-99311: Flywheel holder



26. Tighten IN. camshaft timing sprocket bolt to specified torque.

 IN. camshaft timing sprocket bolt:  
60 N·m (6.0 kg-m, 43.4 lb-ft)

**CAUTION**

Do not over tighten to avoid damaging VVT actuator.

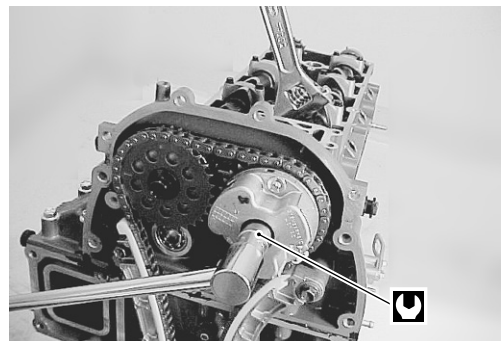



27. Tighten EX. camshaft timing sprocket bolt to specified torque.

 **EX. camshaft timing sprocket bolt:**  
**78 N·m (7.8 kg-m, 56 lb-ft)**

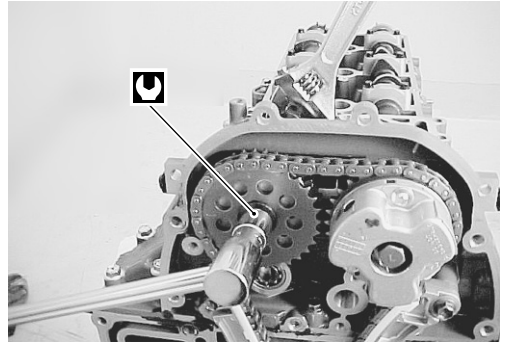

28. Install driven gear holder ②④, then tighten four (4) bolts securely.

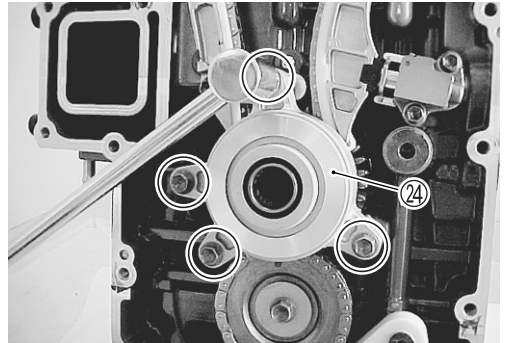

## TIMING CHAIN/BALANCER CHAIN (Non-VVT model)

### REMOVAL

#### Prior to this service work:

- Remove the power unit. (See page 6-15 to 6-20.)

1. Crankshaft/Drive gear/Balancer drive gear
2. Driven gear/Timing sprocket
3. Driven gear holder
4. Chain tensioner adjuster
5. Timing chain tensioner
6. Timing chain guide
7. Timing chain
8. IN. camshaft timing sprocket
9. EX. camshaft timing sprocket
10. Balancer driven sprocket
11. Balancer chain tensioner
12. Balancer chain guide
13. Balancer chain

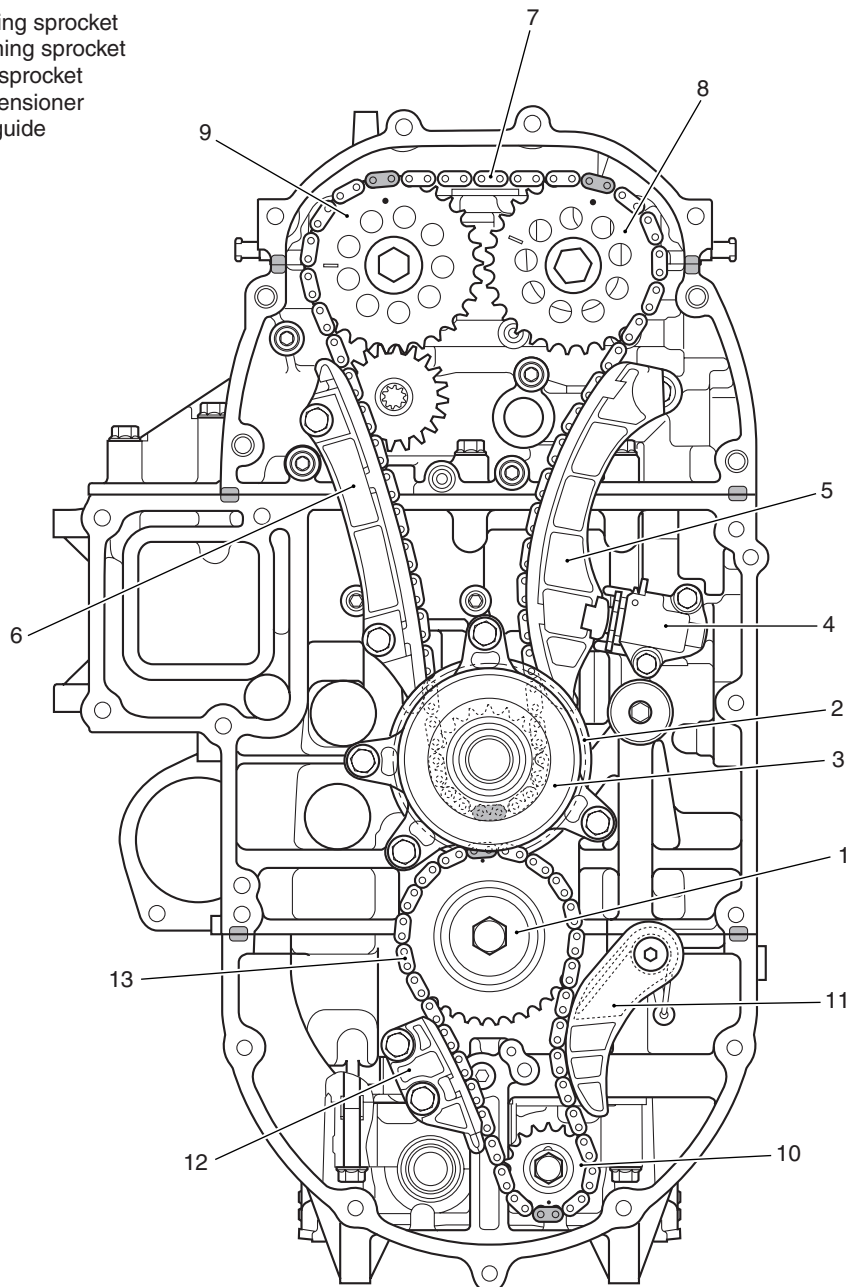

1. Remove the oil pump. (See page 6-26.)
2. Loosen the bolts securing IN./EX. camshaft timing sprockets to each cam shaft.

**NOTE:**

- Sprocket bolt is LH thread.
- Hold camshaft by placing a wrench on the hexagon area of the camshaft.

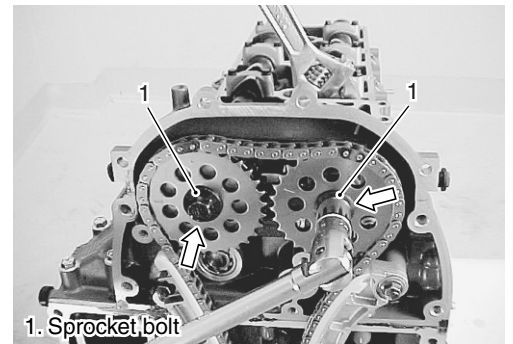

3. Remove the four (4) bolts ① securing driven gear holder ②, then remove the driven gear holder.

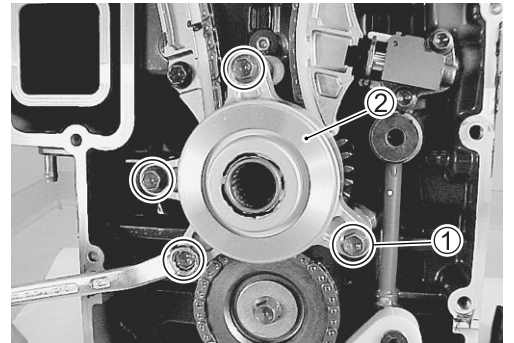

4. Remove bolts ③ and balancer chain guide ④.

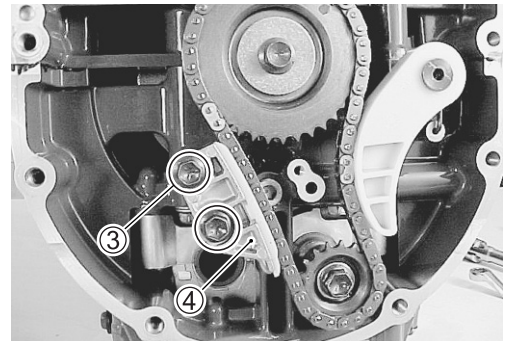

5. Remove bolt ⑤, balancer chain tensioner ⑥ and spring ⑦.

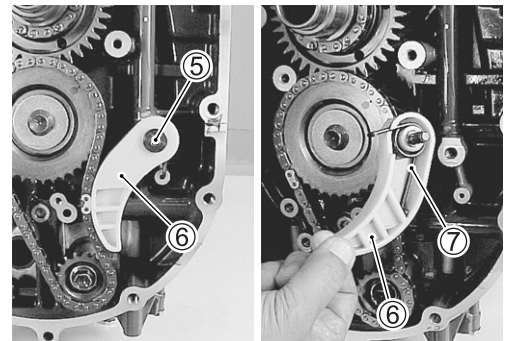

6. Loosen and remove the bolt ⑧ securing balancer drive sprocket ⑨ to crankshaft.

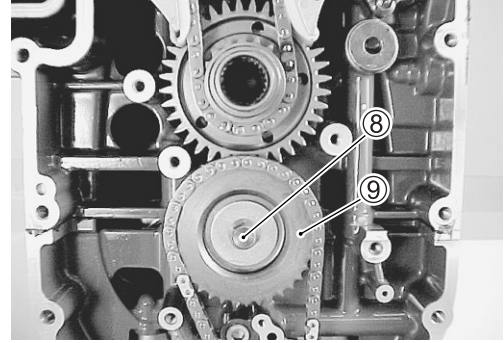

**NOTE:**

To hold the crankshaft, use special tool and flywheel as shown in figure.

 09916-99311: Flywheel holder

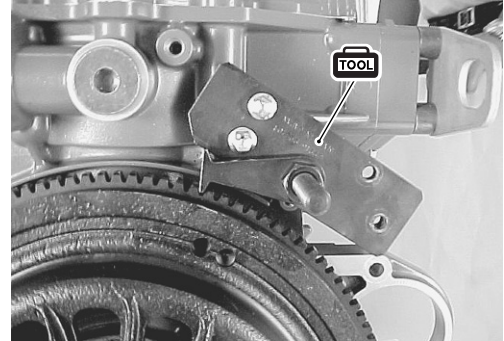

7. Remove the balancer drive sprocket ⑨ and balancer chain ⑩.

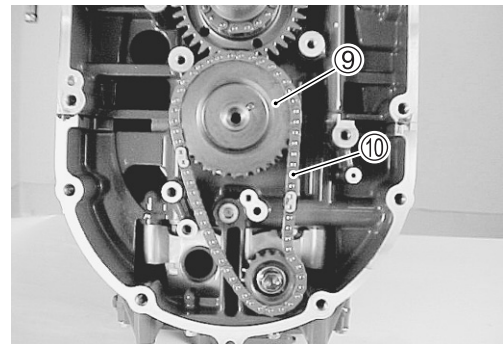

8. Turn the crankshaft in its normal running direction (®\_LH direction) until the match mark (•) on the crankshaft drive gear points to 12 o'clock (toward cylinder head).

**CAUTION**

When timing chain has been removed, never turn crankshaft or camshaft.

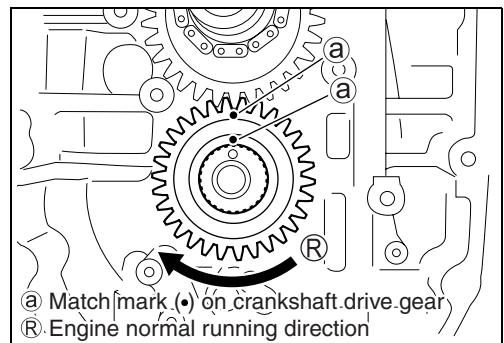

9. Remove bolts ⑪ and timing chain guide ⑫.

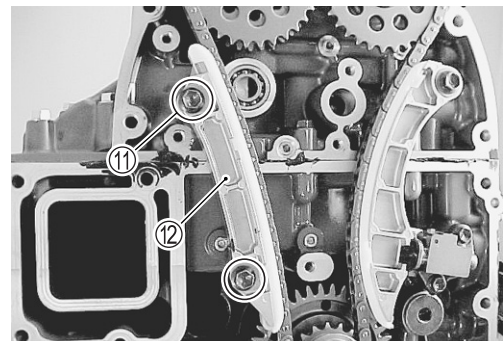



10. Remove bolts ⑬ and chain tensioner adjuster ⑭.

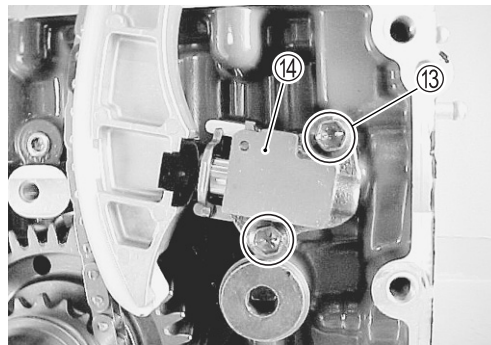

11. Remove bolt ⑮ and timing chain tensioner ⑯.

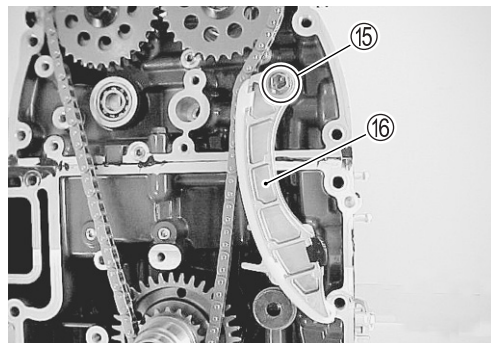

12. Remove bolt ⑰, EX. camshaft timing sprocket ⑱ and timing chain ⑲.  
Remove oil pump drive gear ⑳.

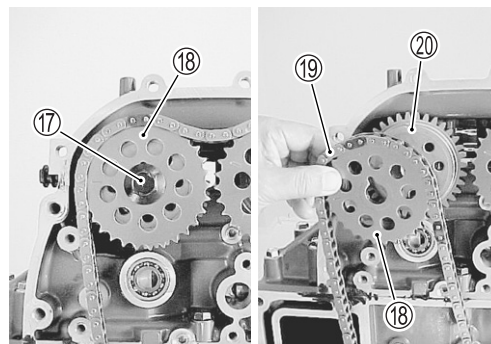

13. Remove bolt ㉑ and IN. camshaft timing sprocket ㉒.

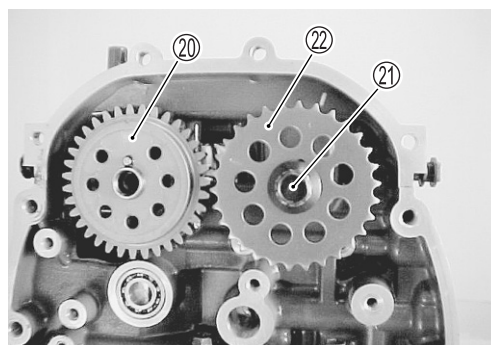

14. Remove driven gear ㉓.

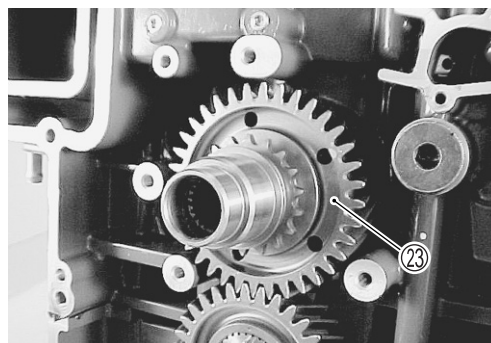



15. Remove drive gear ⑳.

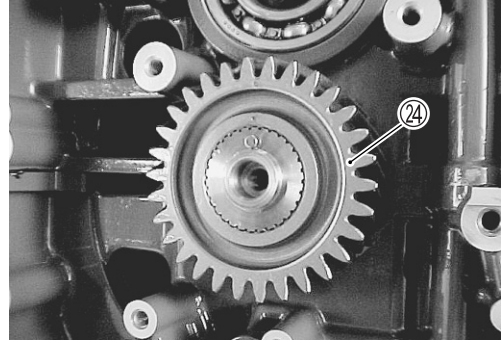

## INSPECTION

### NOTE:

*If any component is worn excessively, cracked, defective or damaged in any way, it must be replaced.*

### TIMING CHAIN

- Inspect timing chain.
- Replace if worn excessively or damaged.

### BALANCER CHAIN

- Inspect balancer chain.
- Replace if worn excessively or damaged.

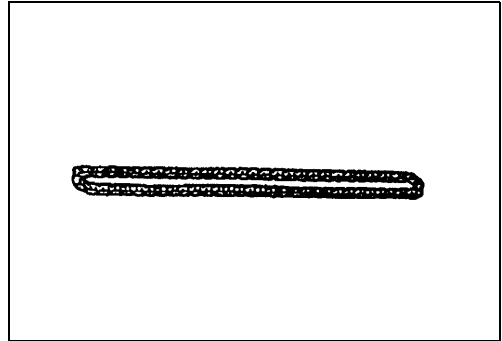

### TENSIONER ADJUSTER

- Inspect tensioner adjuster for smooth operation.
- Replace if faulty.
- Check oil delivery passage to tensioner.

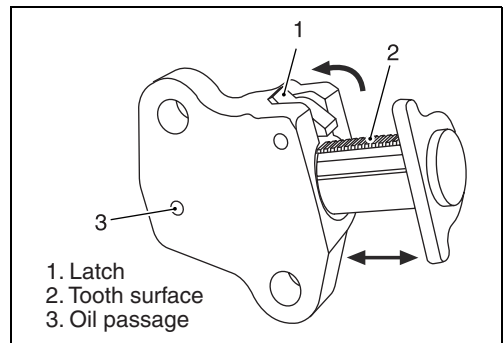

### TIMING CHAIN TENSIONER/CHAIN GUIDE

- Check chain guide shoe for wear or damage.
- If excessive wear or other damage is found, replace it.



**CAMSHAFT TIMING SPROCKET**

- Check teeth of sprocket for wear or damage.  
If excessive wear or other damage is found, replace it.

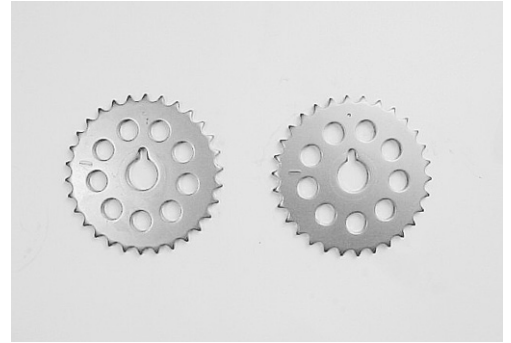
**DRIVEN GEAR HOLDER**

- Check driven gear holder.  
If cracks or other damage is found, replace holder.
- Check driven gear bearing.  
Replace bearing if pitted, noisy, or rough condition.
- Check oil seal.  
If excessive wear or other damage is found, replace oil seal.

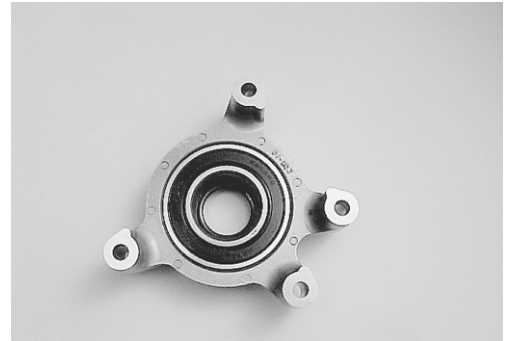
**NOTE:**

Install oil seal lip (spring side) facing as shown in figure.

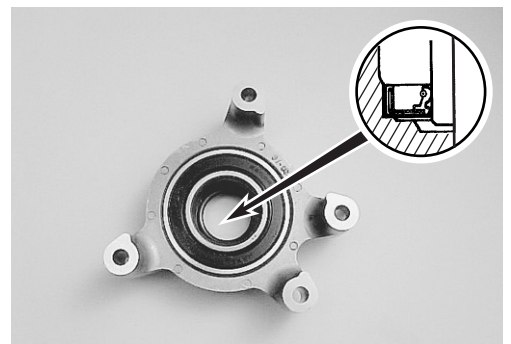
**DRIVE GEAR/DRIVEN GEAR/BEARING**

- Inspect drive and driven gears.  
Replace gear if damaged or worn excessively.
- Check driven gear bearing.  
Replace bearing if pitted, noisy, or rough condition.

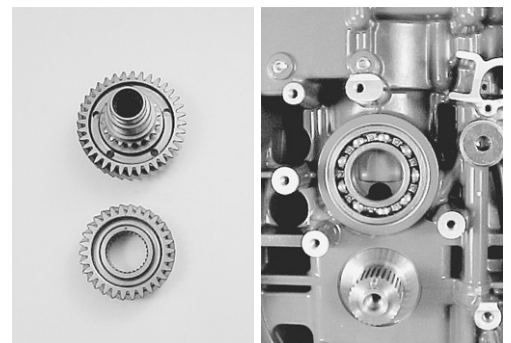
**BALANCER SPROCKET**

- Check teeth of sprocket for wear or damage.  
If excessive wear or other damage is found, replace it.

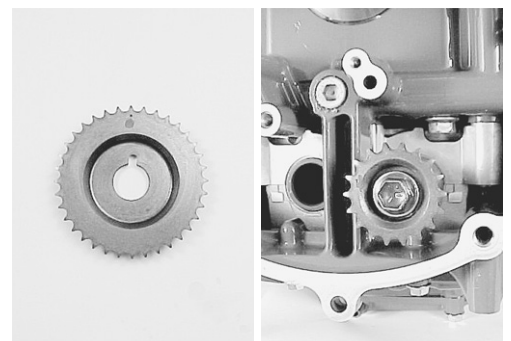

**BALANCER CHAIN TENSIONER/CHAIN GUIDE**

- Check tensioner for wear or damage.  
If excessive wear or other damage is found, replace it.
- Check chain guide for wear or damage.  
If excessive wear or other damage is found, replace it.

**OIL PUMP DRIVE GEAR**

- Inspect drive gear.  
Replace gear if damaged or worn.

**INSTALLATION**

Installation is reverse of removal with special attention to following steps.

1. Install the drive gear ① on crankshaft so that dowel pin hole ② aligns with match mark (•) ③ on the drive gear as shown in illustration.
2. Check that match mark (•) ④ on the crankshaft drive gear points to 12 o'clock (towards cylinder head).
3. Install the driven gear ⑤ on the cylinder block so that match mark (•) ⑥ aligns with match mark (•) ⑦ on the driven gear as shown in illustration.

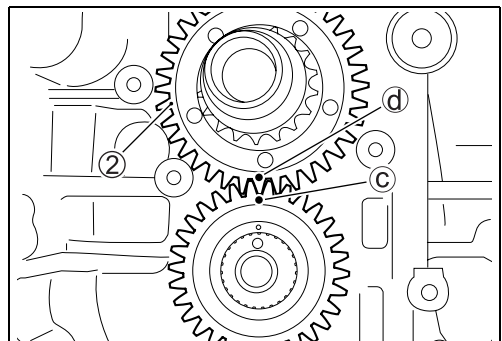
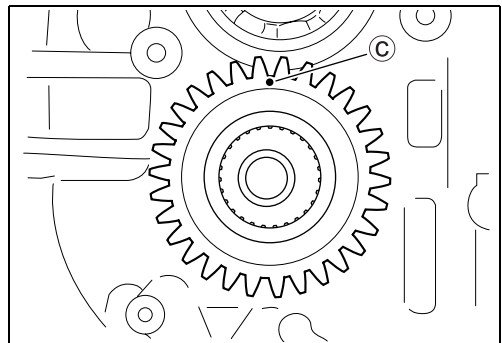
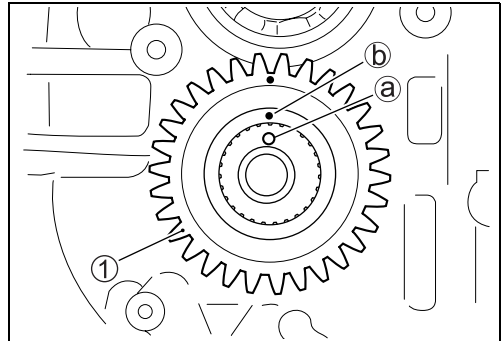

4. Fit the dowel pin ③ onto IN. camshaft. Fit IN. camshaft timing sprocket ④ and temporarily tighten the sprocket bolt. Check that match marks (•) ⑤·⑥ are correctly aligned as shown in illustration.

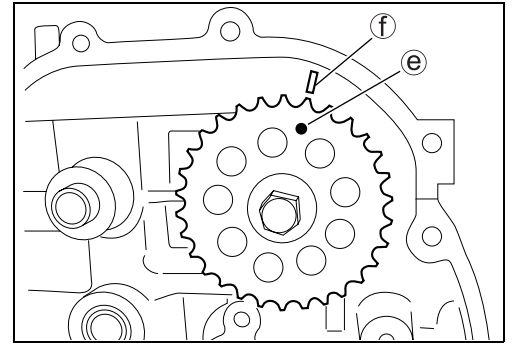
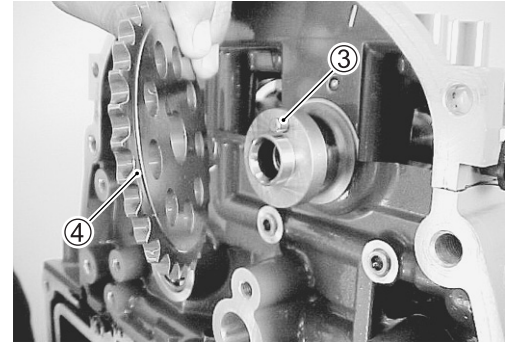

5. Fit the dowel pin ⑤ onto the EX. camshaft.
6. Install oil pump drive gear ⑥.

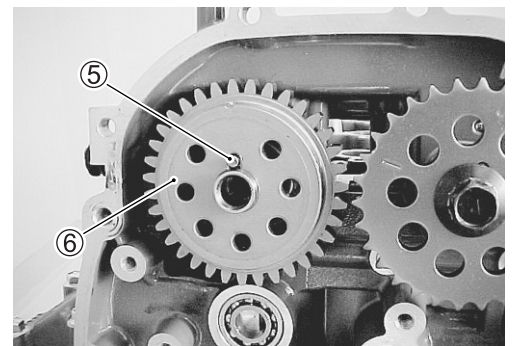

7. Align the yellow plate of timing chain ⑦ with the match mark (•) ⑧ on the driven gear and fit the chain onto the driven gear.

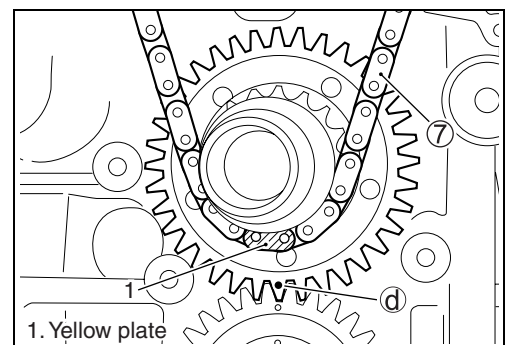

8. As shown in the illustration, fit the timing chain with one blue plate aligned with the match mark (•) ⑨ onto the IN. camshaft timing sprocket.

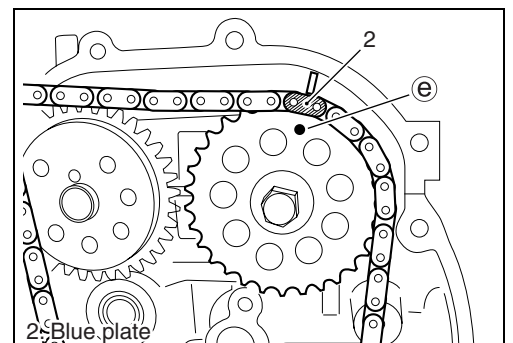



9. While aligning the one blue plate of timing chain with the match mark (•) ⑨ on the EX. camshaft timing sprocket ⑧, fit the chain onto the sprocket.

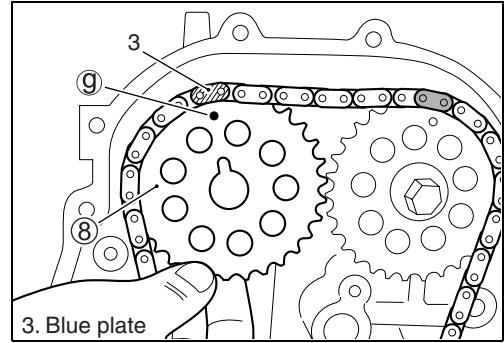

10. Install the EX. camshaft timing sprocket ⑧ on the EX. camshaft, then temporarily tighten the sprocket bolt.

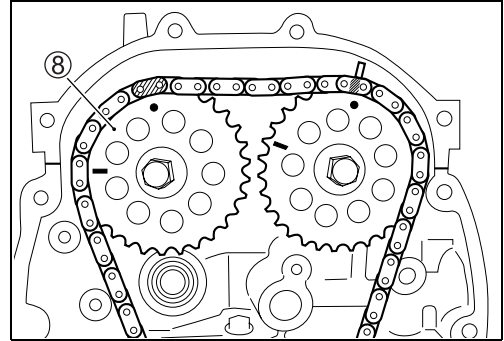

11. Insert the spacer ⑨ into the chain tensioner ⑩.  
Install chain tensioner, then tighten bolt ⑪ securely.  
Apply engine oil to chain tensioner.

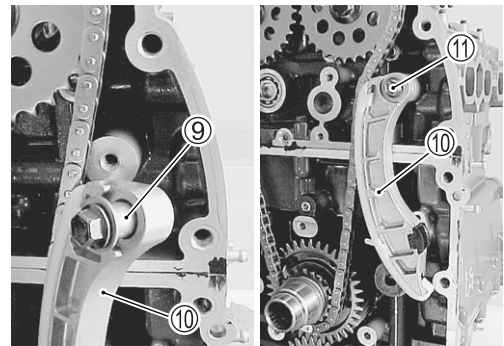

12. With latch of tensioner adjuster ⑫ pushed in and plunger pushed back into body, insert stopper into latch and body.  
After inserting stopper, check to make sure that plunger will not come out.

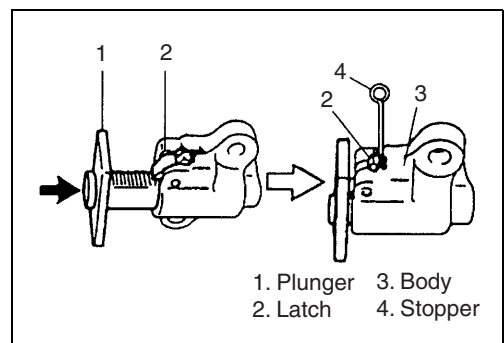

13. Install timing chain tensioner adjuster ⑫, then tighten bolts ⑬ to specified torque.

**⚠ Tensioner adjuster bolt: 11 N·m (1.1 kg-m, 8.0 lb-ft)**

Apply engine oil to timing chain.

14. Remove the stopper from tensioner adjuster.

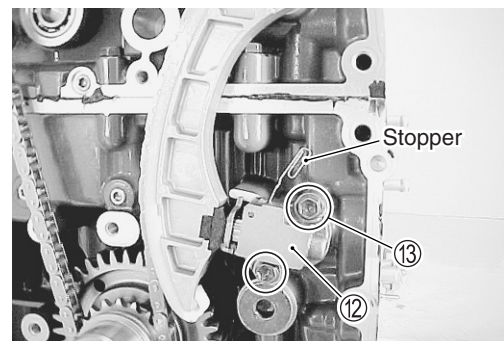

15. Install timing chain guide ⑭, then tighten bolts securely.  
Apply engine oil to chain guide.

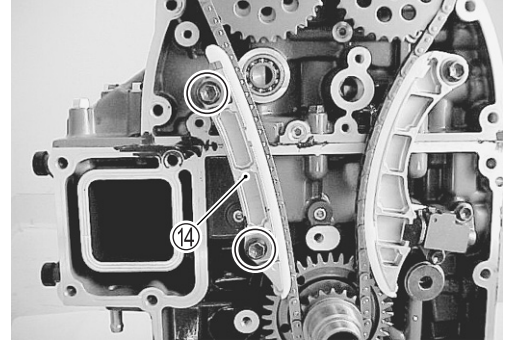

16. Turn the crankshaft two (2) complete rotations in direction shown in figure.

As shown in the illustration, check that all match marks are in alignment as stated below when the match mark (•) ③ on the drive gear is pointing to 12 o'clock.

- The match mark (•) ⑤ on the IN. sprocket aligns with the match mark ① on the camshaft housing.
- The match mark (engraved line) ④ on the EX. sprocket aligns with the mating face ② between cylinder head and lower camshaft housing.

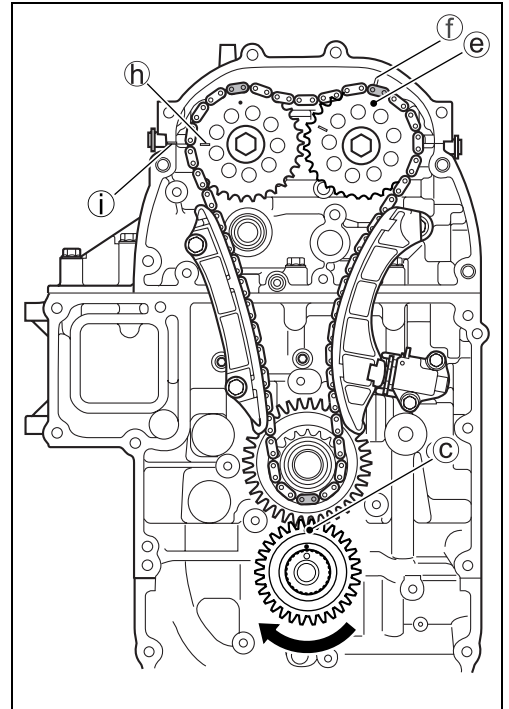

17. Check that match mark (•) ③ on the crankshaft drive gear points to 12 o'clock (towards cylinder head).

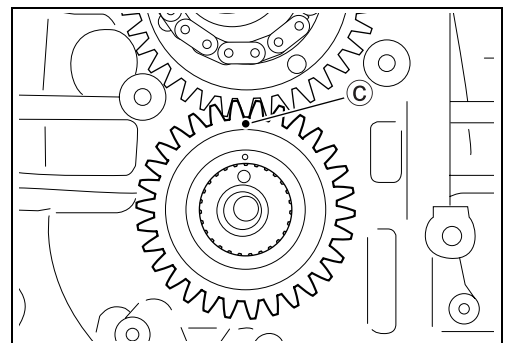

18. Check that match mark (•) ① on the balancer driven sprocket points to 6 o'clock as shown in the illustration.

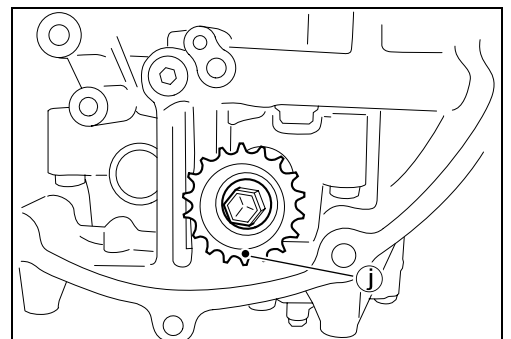

19. Fit the dowel pin ⑮ on the crankshaft.

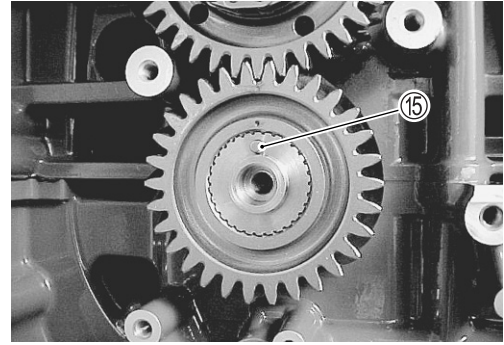

20. Align the yellow plate of balancer chain ⑯ with the match mark (•) ① on the balancer driven sprocket and fit the chain on the sprocket.

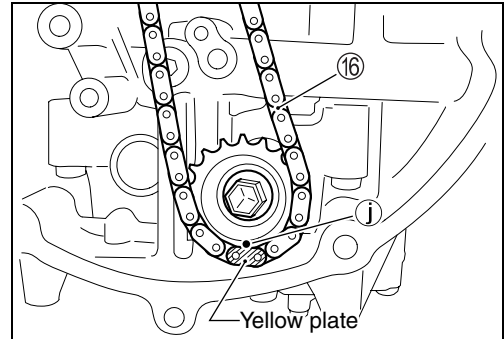

21. Align the yellow plate of balancer chain with the match mark (•) ② on the balancer drive sprocket ⑰ and fit the chain on the sprocket.

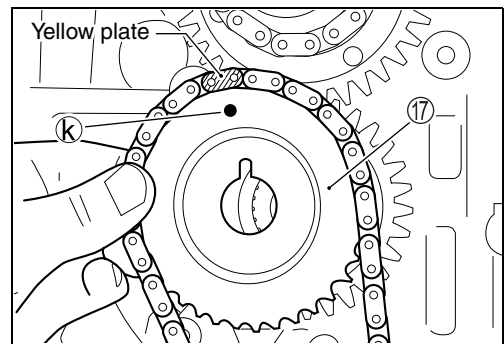

22. Install the balancer drive sprocket ⑰ on the crankshaft, then temporarily tighten the sprocket bolt and washer. Check that match marks ① and ② are correctly aligned as shown in illustration.

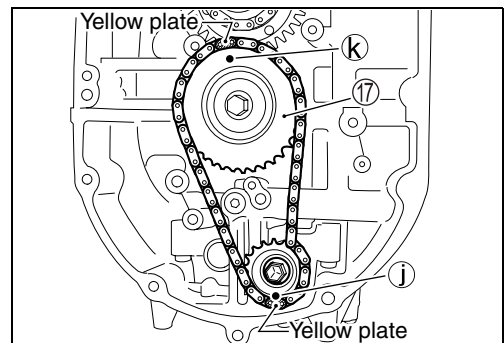

23. Install balancer chain guide ⑱, then tighten bolts ⑲ securely.

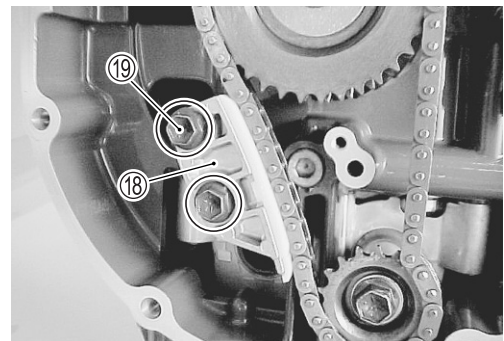

24. Assemble tensioner spring ⑳ and balancer chain tensioner ㉑.

Install chain tensioner ㉑, then tighten bolt ㉒ securely.

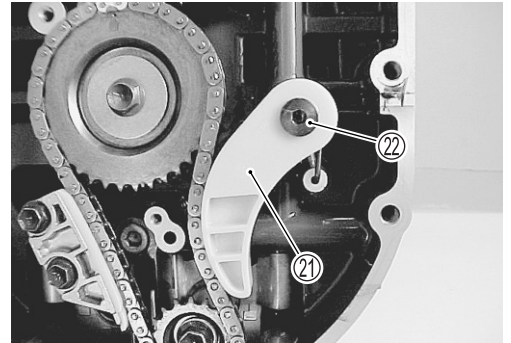
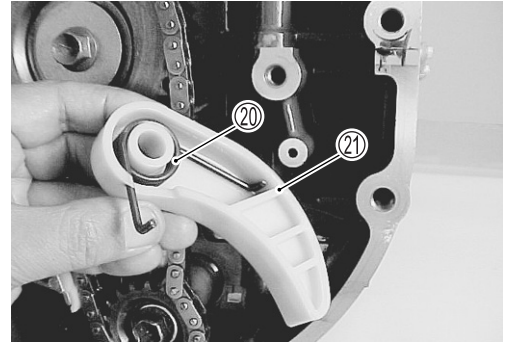

25. Tighten crankshaft drive gear bolt ㉓ to specified torque.

 **Crankshaft drive gear bolt: 48 N·m (4.8 kg-m, 34.7 lb-ft)**

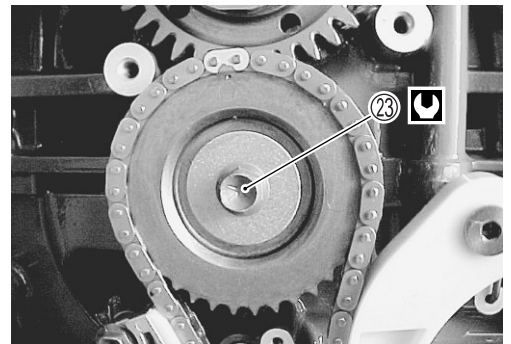

**NOTE:**

To hold the crankshaft, use special tool and flywheel as shown in figure.

 **09916-99311: Flywheel holder**



26. Tighten IN. and EX. camshaft timing sprocket bolt to specified torque.

 **IN. and EX. camshaft timing sprocket bolt:  
78 N·m (7.8 kg-m, 56 lb-ft)**

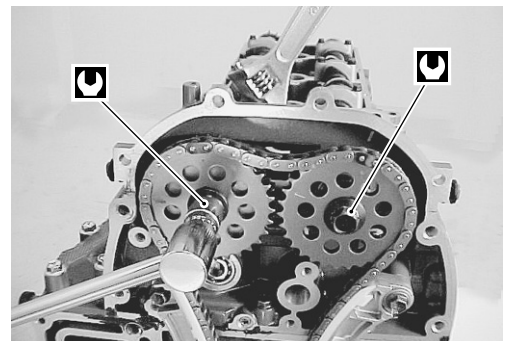



27. Install driven gear holder ⑳, then tighten four (4) bolts securely.

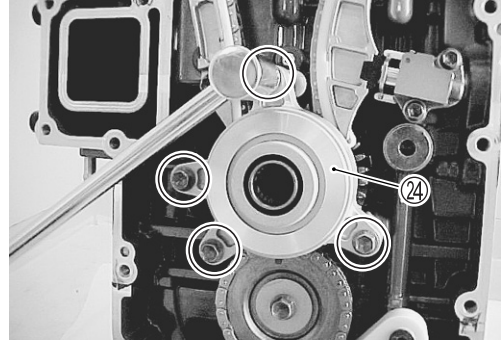

# CYLINDER HEAD ASSEMBLY

(Cylinder head/valve/camshaft)

## REMOVAL

**Prior to removing cylinder head:**

- Remove the power unit. (See page 6-15 to 6-20.)
- Remove the timing chain. (See page 6-31 or 6-44.)

1. On the DF150 model, remove the four (4) bolts and plate ①.

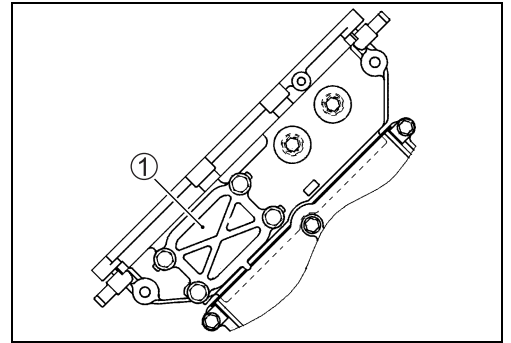

2. Remove two (2) plugs ②.

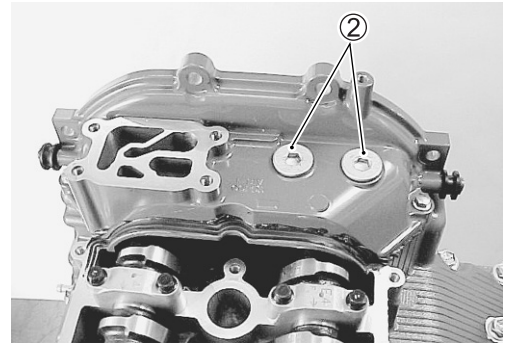

3. Remove the bolts securing the camshaft housing ③ to cylinder head, then remove each camshaft housing.

**NOTE:**

*For ease of assembly, note position of each individual camshaft housing.*

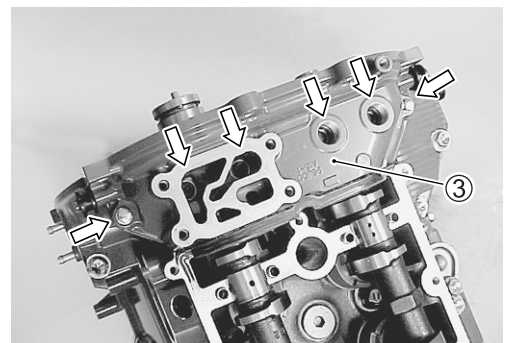
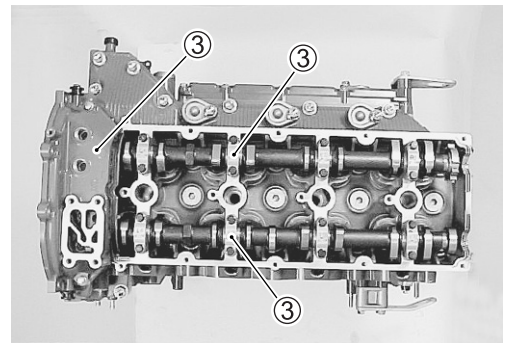

- Remove intake/exhaust camshafts, tappets and tappet shims.

**NOTE:**

All tappets and tappet shims must be installed in their original positions.

For ease of assembly, lay out tappets and record shim thickness for each individual cylinder/valve position.

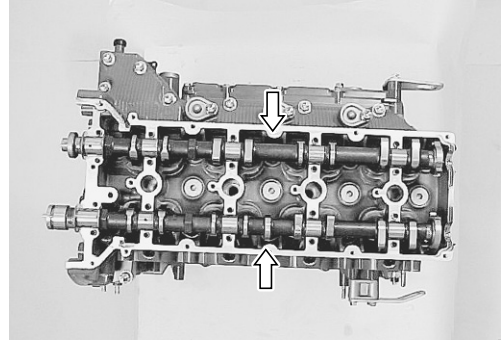

- Loosen and remove twenty (20) cylinder head bolts in the order indicated in figure.  
Remove cylinder head assembly and head gasket.

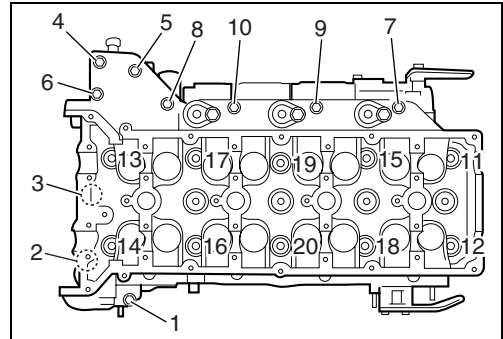
**NOTE:**

Do not forget to remove all bolts in shown figure.

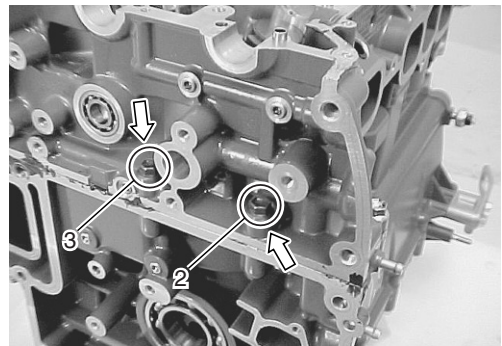
**ASSEMBLY**

Assemble in reverse order of removal paying special attention to the following steps.

**CAUTION**

**Do not reuse gasket. Always use a new gasket.**

- Insert the dowel pins and place a new cylinder head gasket into position on the cylinder.

**NOTE:**

Before installing cylinder head gasket, apply sealant to both surfaces of the hatched areas shown in illustration.

**1207B 99000-31140: SUZUKI BOND "1207B"**

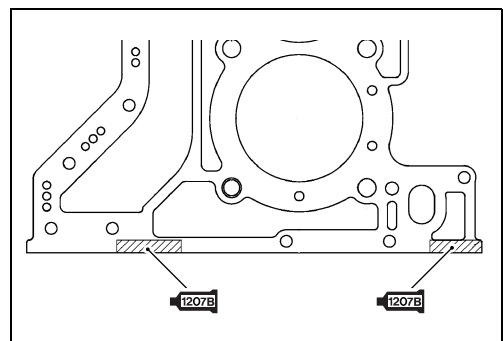
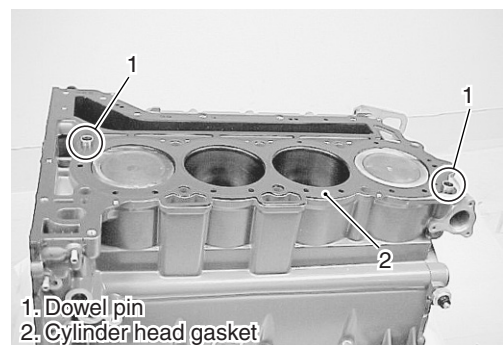

2. Position cylinder head on cylinder.
3. Apply engine oil to cylinder head bolts and tighten them gradually as follows.

**NOTE:**

*Do not forget to install all bolt shown in figure.*

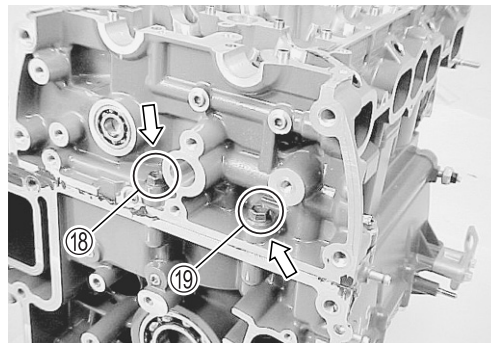

- (a) Tighten all bolts to 50 percent (%) of specified torque according to sequence in figure.

**🔩 Cylinder head bolt:**

**1st step** 12 mm 43 N·m (4.3 kg-m, 31.1 lb-ft)  
8 mm 12 N·m (1.2 kg-m, 8.7 lb-ft)

- (b) Loosen all bolts to 0 N·m (0 kg-m, 0 lb-ft) according to reverse sequence in figure.
- (c) Again tighten all bolts to 50 percent (%) of specified torque according to sequence in figure.

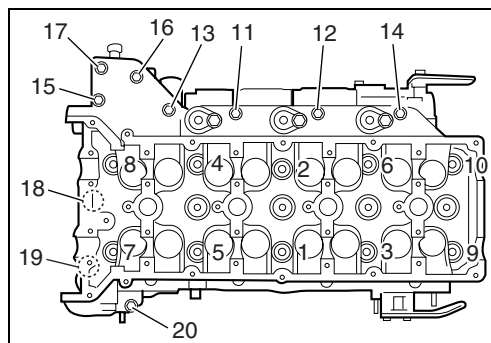

**🔩 Cylinder head bolt:**

**3rd step** 12 mm 43 N·m (4.3 kg-m, 31.1 lb-ft)  
8 mm 12 N·m (1.2 kg-m, 8.7 lb-ft)

- (d) Finally tighten all bolts to specified torque according to sequence in figure.

**🔩 Cylinder head bolt:**

**Final step** 12 mm 86 N·m (8.6 kg-m, 62.2 lb-ft)  
8 mm 23 N·m (2.3 kg-m, 16.6 lb-ft)

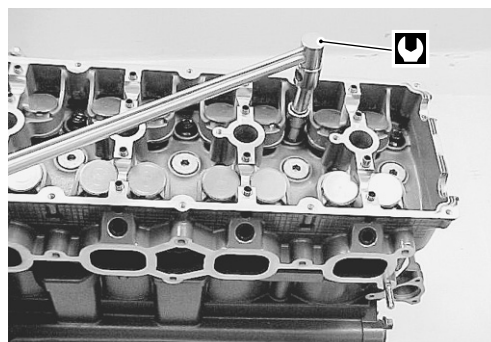

4. Apply engine oil around tappets and install in their original position.  
Install tappet shims in their original position.

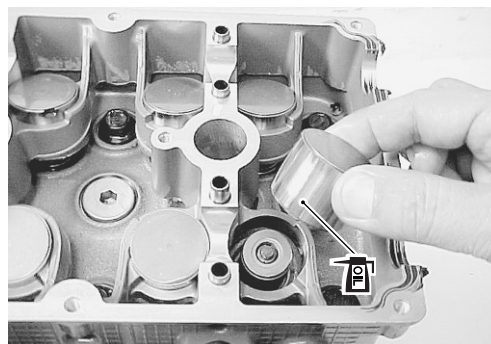



**NOTE:**

Before installing camshafts, turn crankshaft until the match mark (•) on the crankshaft drive gear points to 12 o'clock (toward cylinder head).

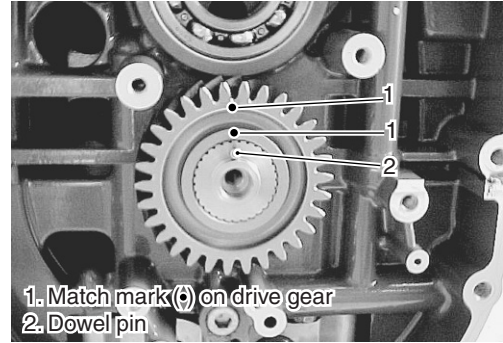

5. Apply engine oil to the surface of each camshaft lobe and journal, then install them as shown in figure.

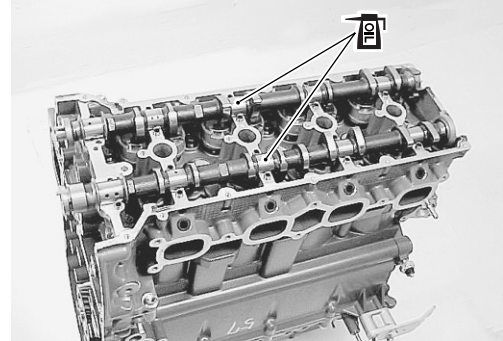

**NOTE:**

When installing the camshaft, align dowel pin on the IN. camshaft with match mark on lower camshaft housing and engraved line on EX. sprocket align with lower camshaft housing mating face.

1. Dowel pin on camshaft
2. Match mark on lower camshaft housing
3. Engraved line on EX. sprocket

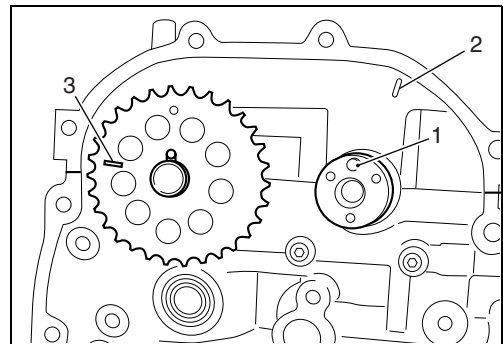

6. Install camshaft housing pins as shown in figure.

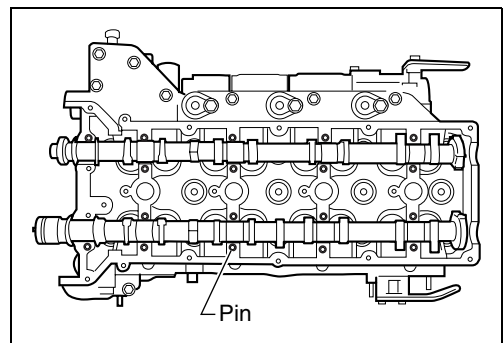

7. Apply sealant to lower camshaft housing sealing surface area as shown in figure.

 99000-31140: SUZUKI BOND "1207B"

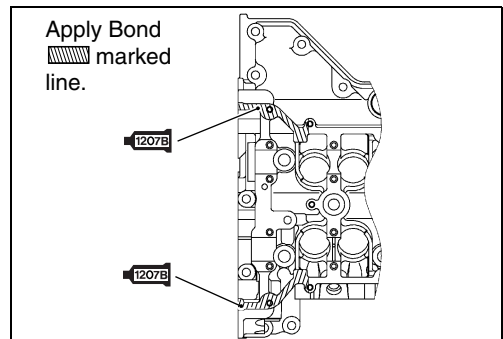

8. Install the lower camshaft housing.

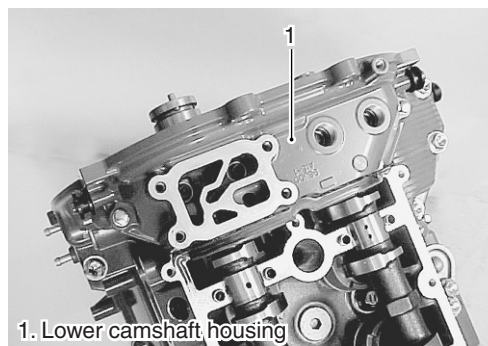

9. Check position of camshaft housing.

- Embossed marks are provided on each camshaft housing indicating position and direction of installation.

Install housings as indicated by these marks.

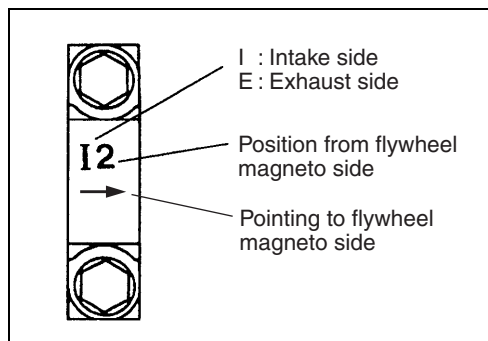

10. Apply engine oil to housing bolts.

11. Lightly seat all housing bolts at first.

Following sequence in figure, tighten bolts to 1/3 of specified torque, then 2/3 of specified torque and finally to full specified torque.

 **Camshaft housing bolt: 12 N·m (1.2 kg·m, 8.7 lb-ft)**

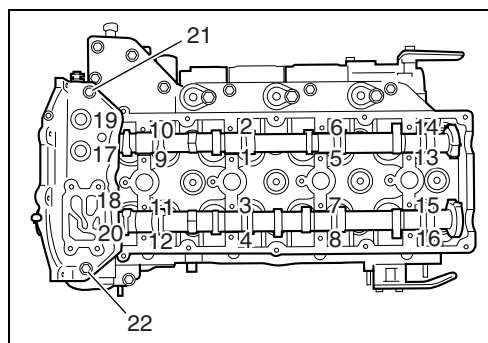

12. Install plugs ① in lower camshaft housing.

13. On the DF150 model, install gasket and plate ②, tighten bolts securely.

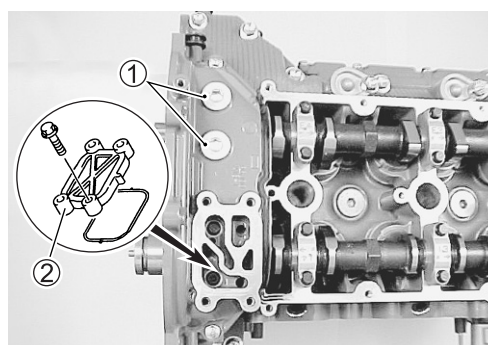

14. Install timing chain and balancer chain.

(See page 6-37 or 6-50.)

15. Install oil pump assembly. (See page 6-30.)

16. Check tappet clearance and adjust as necessary.

(See page 2-9.)

## DISASSEMBLY

1. Remove tappets with shims.

### NOTE:

All tappets and tappet shims must be installed in their original positions.

For ease of assembly, lay out tappets and record shim thickness for each individual cylinder/valve position.



2. Using valve lifter and attachment, remove valve cotter ① while compressing valve spring.

**TOOL** 09916-19030: Valve lifter  
 09916-14521: Attachment  
 09916-84511: Tweezers

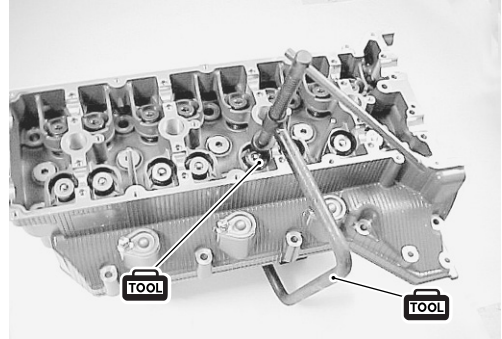

3. Remove valve spring retainer ②, valve spring ③ and valve ④.

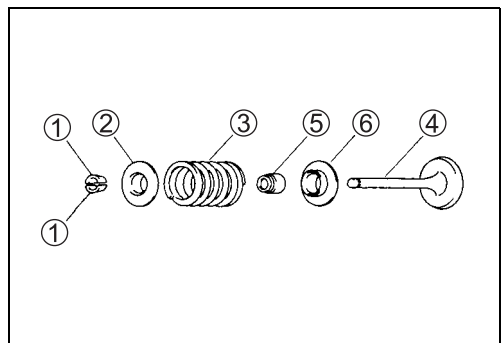
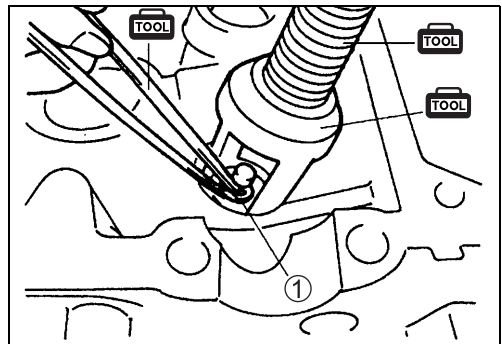

4. Remove valve stem seal ⑤ and valve spring seat ⑥.

### NOTE:

Reassemble each valve and valve spring in their original positions.

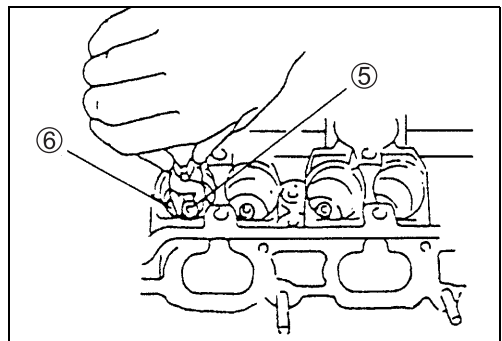

## INSPECTION/SERVICING

### NOTE:

If cracks, excessive wear or other damage is found on any component, replace component.

### CYLINDER HEAD

Remove all carbon from combustion chambers.

### NOTE:

- Do not use any sharp edged tool to scrape carbon off cylinder head or its components.
- Be careful not to scuff or nick metal surfaces when decarbonizing.

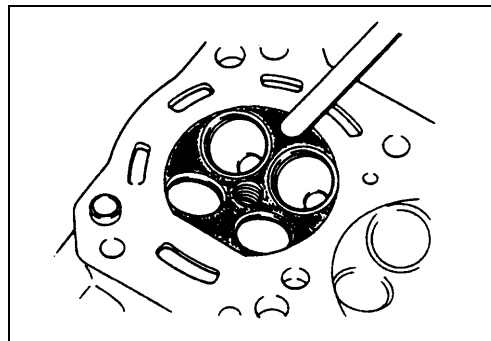

Check cylinder head for cracks in intake and exhaust ports, combustion chambers, and head surface.

### Valve seat

Check valve seat, if cracks or other damage is found, replace cylinder head.

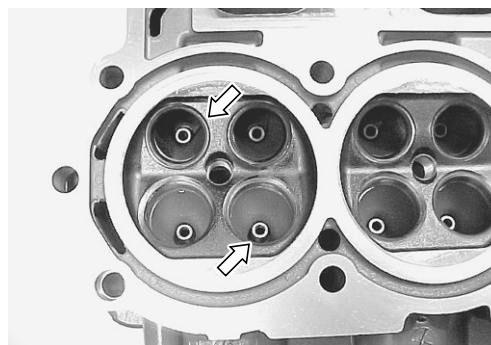

### Cylinder head distortion

Using a straightedge and thickness gauge, measure cylinder head distortion (gasket surface) at a total of six (6) locations as shown.

 **09900-20803: Thickness gauge**

**Cylinder head distortion**

**Service limit: 0.03 mm (0.001 in)**

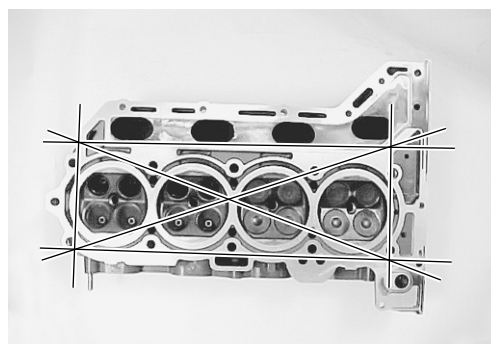

If measurement exceeds service limit, resurface or replace cylinder head.





**Manifold seating faces distortion**

Using a straightedge and thickness gauge, check cylinder head to manifold seating faces.

**Manifold seating faces distortion**  
**Service limit: 0.10 mm (0.004 in)**

If measurement exceeds service limit, resurface or replace cylinder head.

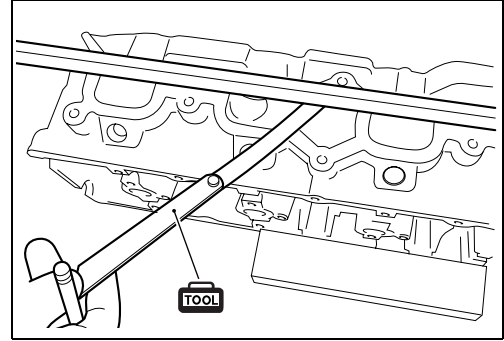
**Water jackets**

Check water jackets. If clogged or obstructed, clean water jackets.

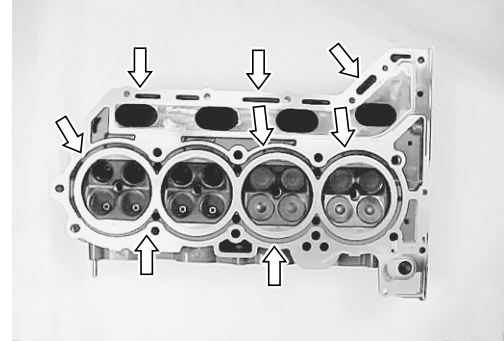
**CAMSHAFT****Cam face**

Inspect cam face for scratches and wear.

**Cam wear**

Using micrometer, measure cam height  $\oplus$ .

 **09900-20202: Micrometer**

**Cam height****Standard:**

**DF175 IN. 44.420 – 44.580 mm (1.7488 – 1.7551 in)**

**EX. 44.420 – 44.580 mm (1.7488 – 1.7551 in)**

**DF150 IN. 42.520 – 42.680 mm (1.6740 – 1.6803 in)**

**EX. 42.420 – 42.580 mm (1.6701 – 1.6764 in)**

**Service limit**

**DF175 IN. 44.320 mm (1.7449 in)**

**EX. 44.320 mm (1.7449 in)**

**DF150 IN. 42.420 mm (1.6701 in)**

**EX. 42.320 mm (1.6661 in)**

If measurement exceeds service limit, replace camshaft.

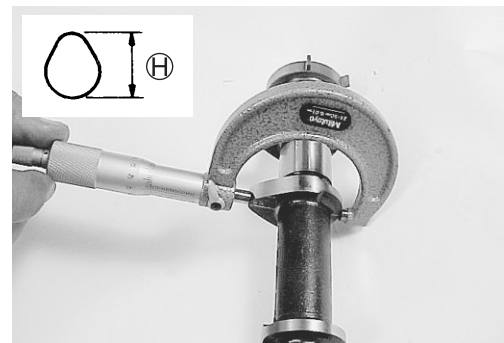

### Camshaft identification

DF150 and DF175 camshafts differ as indicated below.

Model	Identification mark	
	IN.	EX.
DF150	0	A
DF175	1	B

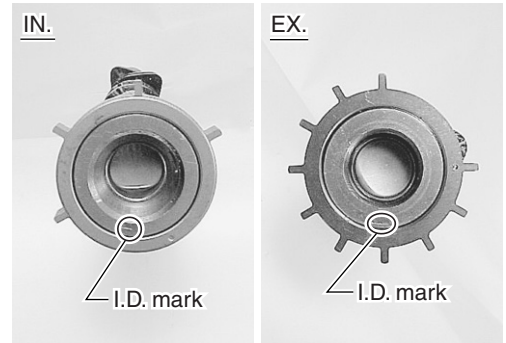

### Camshaft runout

Support camshaft on a surface plate using a set of V-blocks. Measure runout using a dial gauge.

- TOOL 09900-20606: Dial gauge**  
: "V" block set
- 09900-20701: Magnetic stand**

#### Camshaft runout

**Service limit: 0.10 mm (0.004 in)**

If measurement exceeds service limit, replace camshaft.

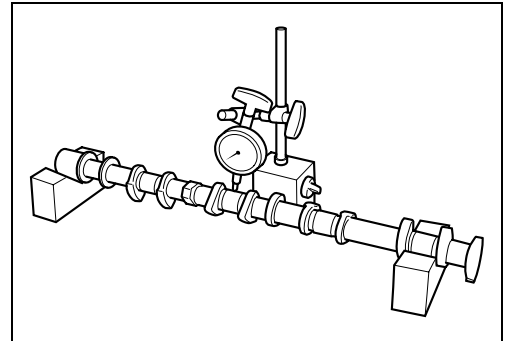

### CAMSHAFT JOURNAL

Check camshaft journals and camshaft housing for pitting, scratches, wear or damage.

If any of the above conditions are found, replace camshaft or cylinder head with housing.

#### NOTE:

*Camshaft housing and cylinder head must be replaced as a set.*

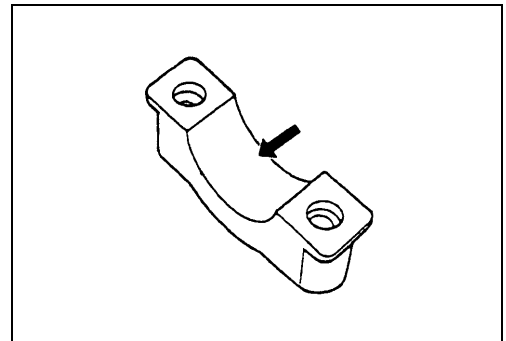

### Camshaft journal oil clearance

Check journal oil clearance using Plastigauge as follows.

1. Clean housing and camshaft journals.
2. Install camshaft to cylinder head.
3. Place Plastigauge across the full width of camshaft journal (parallel to camshaft).

- TOOL 09900-22302: Plastigauge**

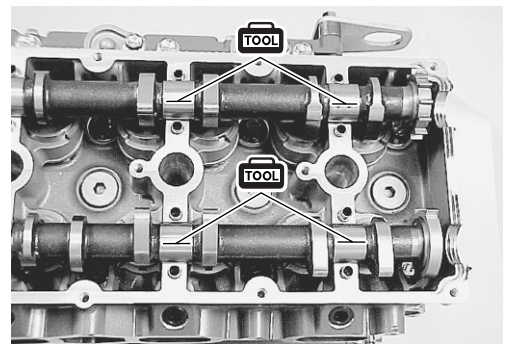

4. Install camshaft housing. Tighten housing bolts in 3 steps (1/3 of specification, 2/3 of specification, full torque specification) in the indicated order.

- Camshaft housing bolt: 12 N·m (1.2 kg·m, 8.7 lb·ft)**

#### NOTE:

*Do not rotate camshaft while Plastigauge is installed.*

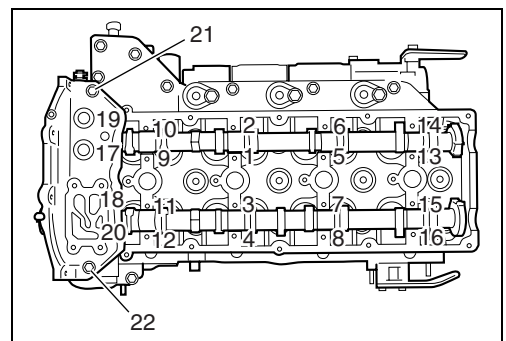

5. Remove camshaft housing.
6. Using scale on Plastigauge envelope, measure Plastigauge at its widest point.

#### Camshaft journal oil clearance

**Standard: 0.043 – 0.085 mm (0.0017 – 0.0033 in)**

**Service limit: 0.120 mm (0.0047 in)**

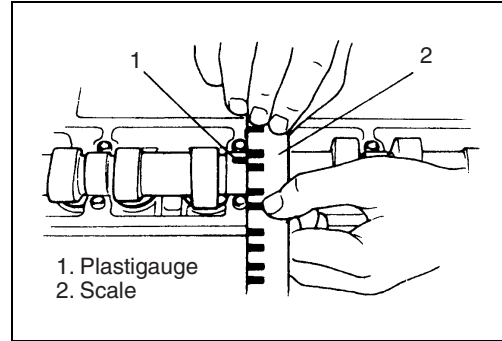

If journal oil clearance exceeds the service limit, measure camshaft journal (outside dia.) and camshaft housing (inner dia.). Based on measurements, replace camshaft and/or cylinder head with camshaft housing.

**TOOL 09900-20202: Micrometer (25 – 50 mm)**

#### Camshaft journal outside diameter

**Standard: 25.936 – 25.957 mm (1.0211 – 1.0219 in)**

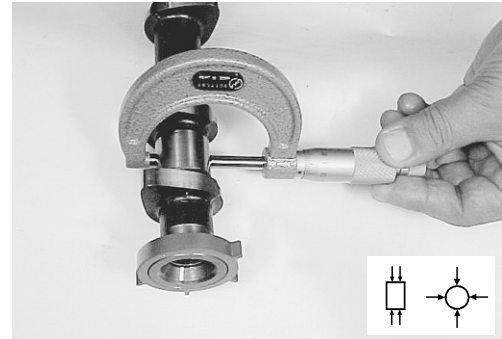

#### Camshaft journal (housing) inside diameter

**Standard: 26.000 – 26.021 mm (1.0236 – 1.0244 in)**

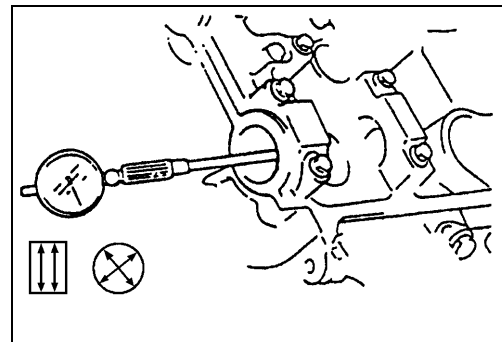

#### TAPPET/TAPPET SHIM

##### Wear of tappet and shim

Check tappet and shim for pitting, scratches, or damage.

If any above conditions are found, replace component.

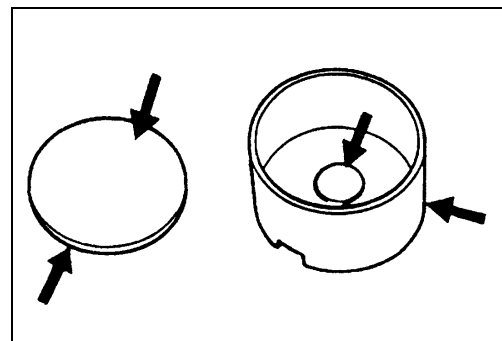

Measure cylinder head bore and tappet outside diameter to determine cylinder head to tappet clearance.

**TOOL 09900-20202: Micrometer**

If measurement exceeds service limit, replace tappet or cylinder head.

**Cylinder head bore to tappet clearance**

**Standard: 0.025 – 0.066 mm (0.0010 – 0.0026 in)**

**Service limit: 0.150 mm (0.0059 in)**

**Tappet outer diameter**

**Standard: 33.959 – 33.975 mm (1.3370 – 1.3376 in)**

**Cylinder head bore**

**Standard: 34.000 – 34.025 mm (1.3386 – 1.3396 in)**

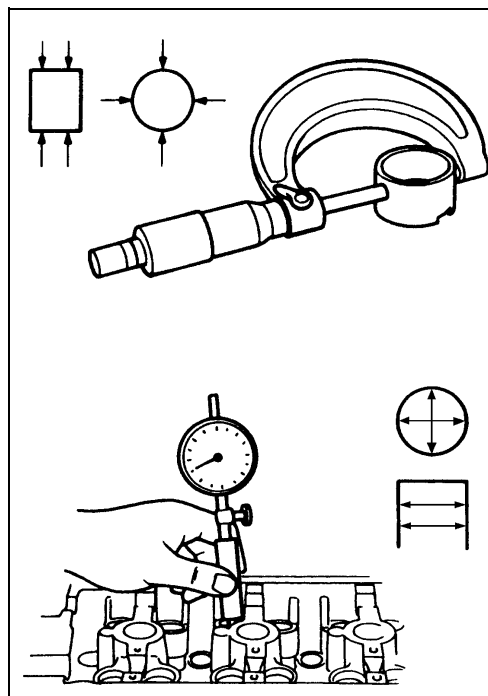

**VALVE/VALVE GUIDE**

**Valve guide to valve stem clearance**

Using a micrometer and bore gauge, take diameter readings on valve stems and guides to check guide to stem clearance.

Be sure to take readings at more than one place along the length of each stem and guide.

**TOOL 09900-20205: Micrometer**

**Valve stem outside diameter**

Using micrometer, measure valve stem outside diameter.

**Valve stem outside diameter**

**Standard:**

**IN. 5.465 – 5.480 mm (0.2152 – 0.2157 in)**

**EX. 5.440 – 5.455 mm (0.2142 – 0.2148 in)**

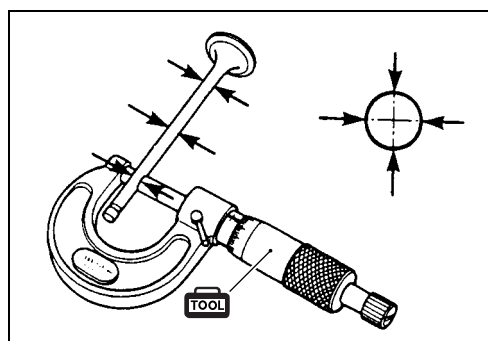

**Valve guide inside diameter**

Using a small bore gauge, measure valve guide inside diameter.

**Valve guide inside diameter**

**Standard:**

**IN. 5.500 – 5.512 mm (0.2165 – 0.2170 in)**

**EX. 5.500 – 5.512 mm (0.2165 – 0.2170 in)**

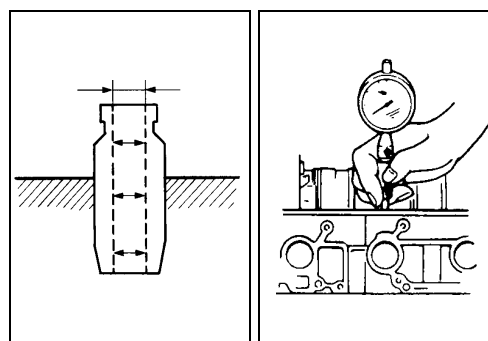



**Valve guide to valve stem clearance****Valve guide to valve stem clearance****Standard:****IN. 0.020 – 0.047 mm (0.0008 – 0.0019 in)****EX. 0.045 – 0.072 mm (0.0018 – 0.0028 in)****Service limit:****IN. 0.070 mm (0.0028 in)****EX. 0.090 mm (0.0035 in)**

If measurement exceeds service limit, replace valve and/or valve guide.

**NOTE:**

For valve guide replacement, see “VALVE GUIDE REPLACEMENT” section on page 6-71.

**Valve stem deflection**

If unable to measure valve guide inside diameter, check “Valve stem deflection”.

**TOOL** 09900-20606: Dial gauge  
09900-20701: Magnetic stand

Measure valve stem deflection as follows:

- (1) Install valve into valve guide.
- (2) Position valve head at approx. 5 mm away from valve seat.
- (3) Move valve head in the direction “X – Y”, and measure deflection.

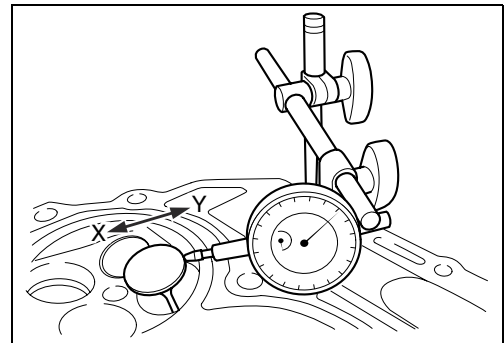
**Valve stem deflection****Service limit:****IN. 0.14 mm (0.0055 in)****EX. 0.18 mm (0.0071 in)**

If measurement exceeds service limit, replace valve.

If measurement still exceeds service limit with new valve, replace valve guide.

**Valve stem end**

Inspect valve stem end face for pitting and wear.

If pitting or wear is found, valve stem end may be resurfaced.

Use caution when resurfacing, do not grind away stem end chamfer.

When chamfer has been worn away, replace valve.

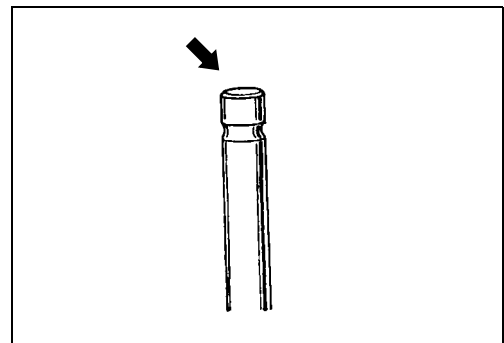

**Valve stem runout**

Measure valve stem runout.

- TOOL** 09900-20606: Dial gauge  
 09900-20701: Magnetic stand  
 09900-21304: "V" block set

**Valve stem runout**

**Service limit: 0.05 mm (0.0020 in)**

If measurement exceeds service limit, replace valve.

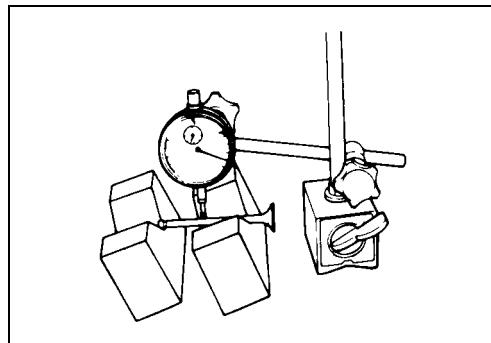
**Valve head radial runout**

Measure valve head radial runout.

- TOOL** 09900-20606: Dial gauge  
 09900-20701: Magnetic stand  
 09900-21304: "V" block set

**Valve head radial runout**

**Service limit: 0.08 mm (0.0031 in)**

If measurement exceeds service limit, replace valve.

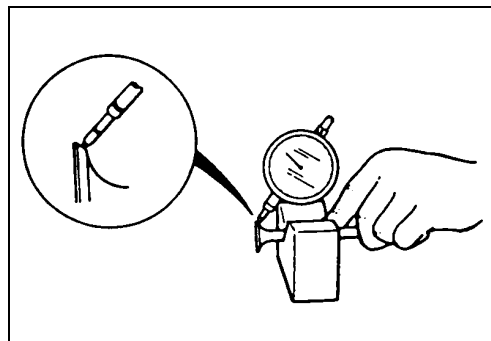
**Valve head thickness**

Measure thickness  $\text{T}$  of valve head.

- TOOL** 09900-20101: Vernier calipers

**Valve head thickness**

**Standard:**

**IN. 1.1 mm (0.0433 in)**

**EX. 1.0 mm (0.0394 in)**

**Service limit:**

**IN. 0.7 mm (0.0276 in)**

**EX. 0.7 mm (0.0276 in)**

If measurement exceeds service limit, replace valve.

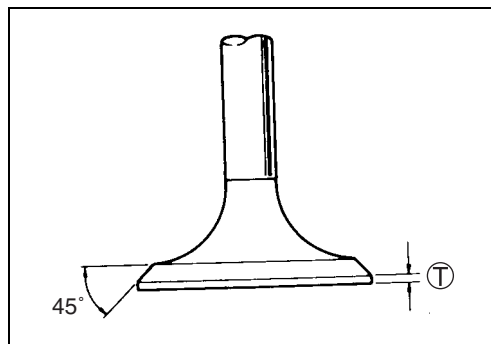
**Valve seat contact width**

Measure valve seat contact width as follows:

- (1) Remove all carbon from valve and seat.
- (2) Coat valve seat evenly with Prussian blue (or equivalent).
- (3) Install valve into valve guide.
- (4) Put valve lapper on valve.

- TOOL** 09916-10911: Valve lapper

- (5) Rotate valve while gently tapping valve contact area against seat.
- (6) Continuously pattern on valve seating face with Prussian blue.
- (7) Measure valve seat contact width  $\text{A}$ .

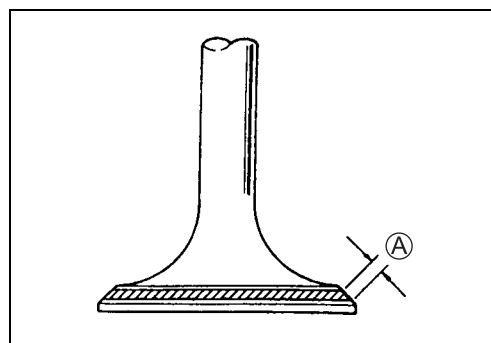
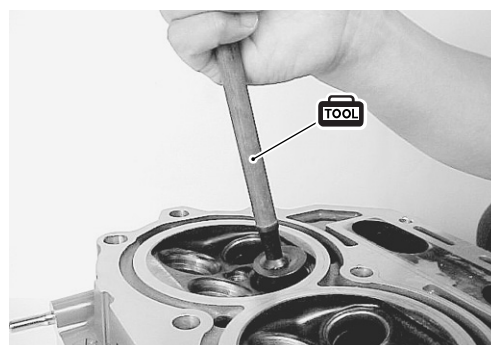

**TOOL** 09900-20101: Vernier calipers**Valve seat contact width (A)****Standard:****IN. & EX. 1.1 – 1.3 mm (0.0433 – 0.0512 in)**

If measurement exceeds specification, repair valve seat.

**NOTE:**

For valve seat repair, see "Valve seat servicing" section on page 6-70.

**VALVE SEAT SERVICING**

If valve seat contact width is out of specification, reface valve seat as follows:

**Valve seat angle****Intake side : 15°, 45°, 60°****Exhaust side : 15°, 45°, 60°**

- TOOL** : Valve seat cutter (NEWAY128) 45°  
 : Valve seat cutter (NEWAY212) 15°  
 09916-22420: Valve seat cutter (NEWAY114) 60°  
 Solid pilot (NEWAY, N-150-5.5)  
 09916-24450: Solid pilot (NEWAY, N-100-5.52)  
 09916-54910: Handle (N-505)

**NOTE:**

Turn cutter clockwise, never counterclockwise.

- (1) Remove all carbon from valve and valve seat.
- (2) Using 45° angle cutter, reface valve seat.
- (3) Check valve seat contact width (A).  
See the "Valve seat contact width" section on page 6-69.
- (4) • If width (A) is too high (or wide), reface valve seat using 15° angle cutter.  
• If width (A) is too low (or narrow), reface valve seat using 60° angle cutter.
- (5) Clean up any burrs using 45° angle cutter very lightly.

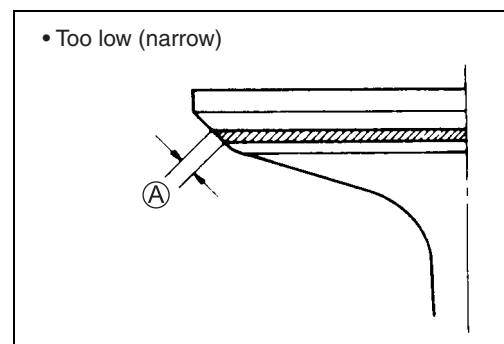
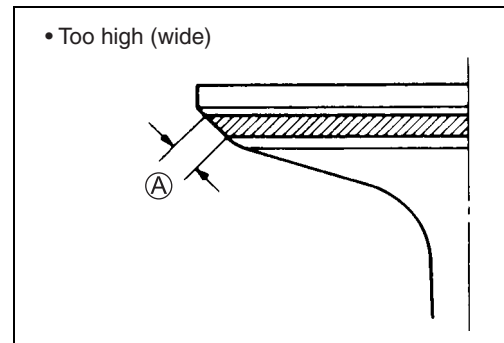
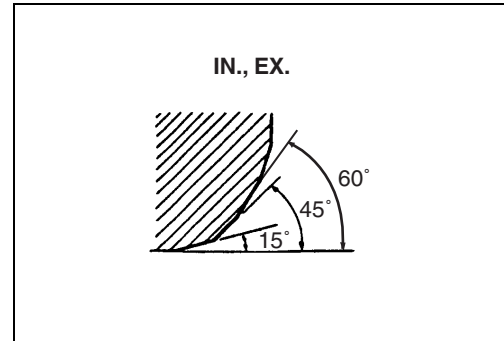
**CAUTION**

**Cut seat areas minimally only.  
Do not cut more than necessary.**

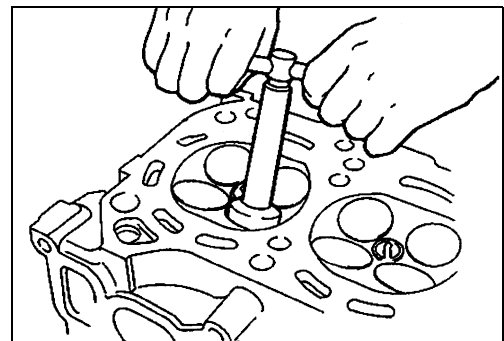

- (6) Lap valve on seat in two steps, first with coarse grit lapping compound applied to face and the second with fine grit compound.
- (7) Recheck valve seat contact width  $\text{\textcircled{A}}$ .

**NOTE:**

*Clean and assemble cylinder head and valve components.*

*Fill intake and exhaust ports with solvent to check for leaks between valve seat and valve.*

*If any leaks occur, inspect valve seat and face for burrs or other things that could prevent valve from sealing.*

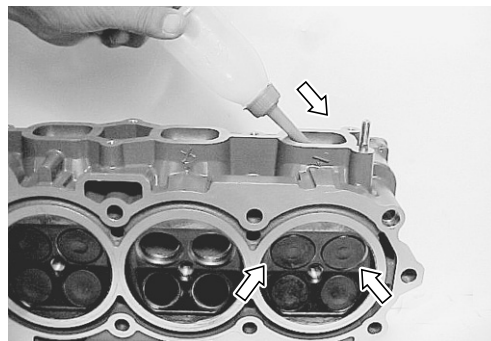
**VALVE GUIDE REPLACEMENT****CAUTION**

**Be careful not to damage cylinder head when replacing valve guide.**

- (1) Using valve guide remover, drive valve guide out from combustion chamber side towards valve spring side.

**TOOL 09916-44310: Valve guide remover**

**NOTE:**

*Do not reuse valve guide once it has been removed.*

*Always use a new valve guide (oversize) when assembling.*

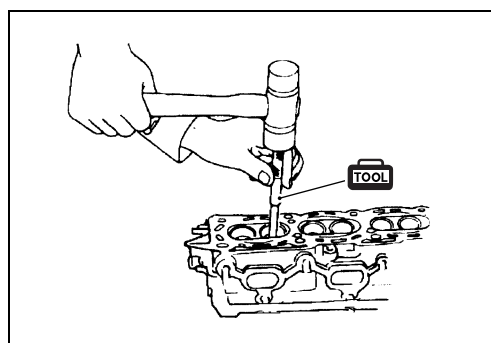

- (2) Ream valve guide hole with  $\phi 10.5$  mm reamer to true hole and remove burrs.

**TOOL 09916-37320: Valve guide reamer ( $\phi 10.5$  mm)**  
**09916-34542: Reamer handle**

**NOTE:**

*Turn reamer clockwise, never counterclockwise.*

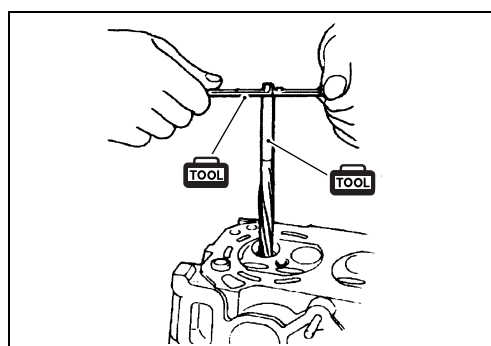



(3) Install valve guide to cylinder head.

- Heat cylinder head to a temperature of 80 – 100 °C (176 – 212 °F).  
Apply heat uniformly so that head will not be distorted.
- Use special tools to drive new valve guide into hole.  
Drive in new valve guide until special tool (valve guide installer attachment) contacts cylinder head.
- After installing, check valve guide protrusion  $\text{H}$ .

 **09916-57330: Valve guide installer handle (A)**  
**09916-56011: Valve guide installer attachment (B)**

**Valve guide protrusion  $\text{H}$**

**Standard:**

**IN. & EX. 11.5 mm (0.4528 in)**

(4) Ream valve guide bore with  $\phi 5.5$  mm reamer.

 **09916-34550: Valve guide reamer ( $\phi 5.5$  mm)**  
**09916-34542: Reamer handle**

**NOTE:**

*Clean and oil valve guide bore after reaming.*

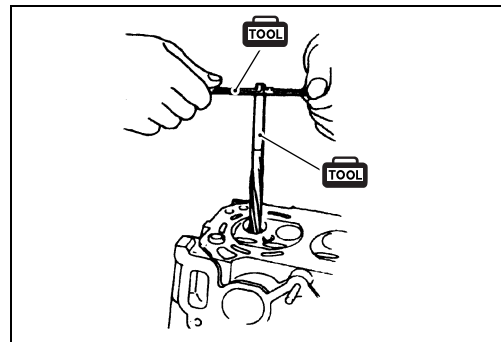
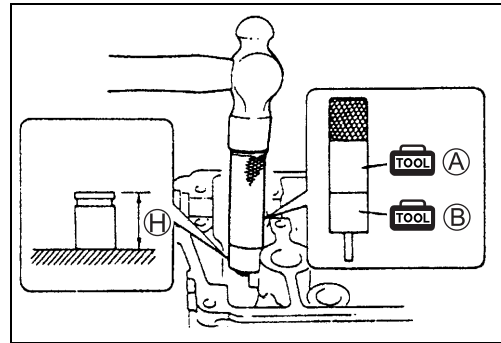

## VALVE SPRING

### Valve spring free length

Check spring strength by measuring free length.

 **09900-20101: Vernier calipers**

**Valve spring free length**

**Standard:**

**IN. & EX. 40.20 mm (1.5827 in)**

**Service limit:**

**IN. & EX. 38.60 mm (1.5200 in)**

If lower than service limit, replace valve spring.

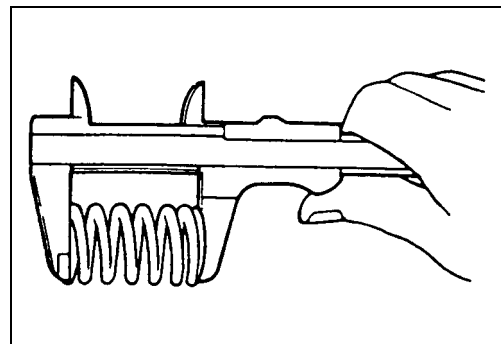

### Valve spring preload

Measure valve spring preload.

 **09900-20101: Vernier calipers**

**Valve spring preload**

**Standard:**

**IN. & EX. 147 – 173 N (15.0 – 17.7 kg, 33.0 – 38.9 lbs)**  
**for 31.1 mm (1.22 in)**

**Service limit:**

**IN. & EX. 136 N (13.9 kg, 30.6 lbs)**  
**for 31.1 mm (1.22 in)**

If lower than service limit, replace valve spring.

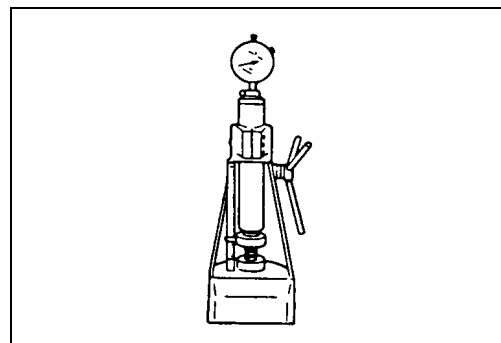

**Valve spring squareness**

Use a square and surface plate to check each spring for squareness (clearance between end of valve spring and square).

 **09900-20101: Vernier calipers**

**Valve spring squareness**

**Service limit:**

**IN. & EX. 2.0 mm (0.079 in)**

If measurement exceeds service limit, replace valve spring.

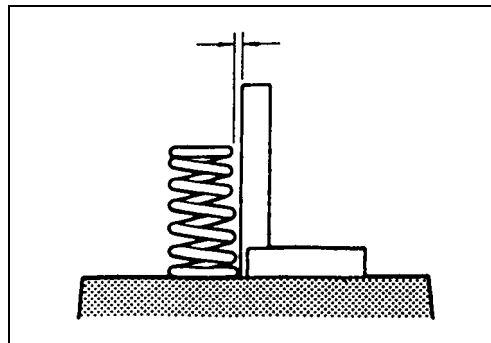
**REASSEMBLY**

Reassemble in reverse order of disassembly paying special attention to the following steps.

**VALVE**

Install valve spring seat ① to cylinder head.

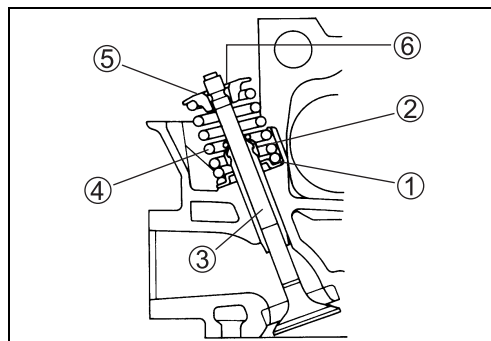

After applying engine oil to stem seal ② and spindle of special tool (Installer attachment), fit stem seal to spindle.

Then, pushing special tool by hand, install stem seal to valve guide.

Check to be sure that seal is properly fixed to valve guide.

 **09917-98221: Installer attachment A**

**09916-57330: Installer handle B**

**CAUTION**

**Do not reuse stem seal once removed.  
Always install new seal.**

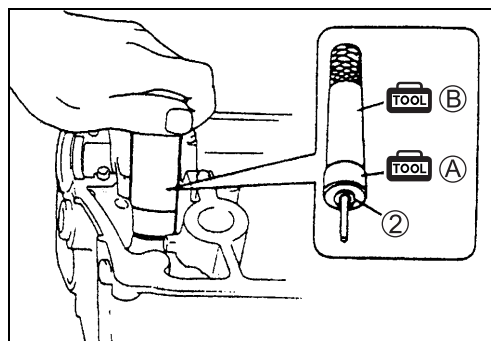

Apply engine oil to stem seal, valve guide bore and valve stem.

Install valve ③ to valve guide.

**NOTE:**

*Reassemble each valve and valve spring to their original position.*

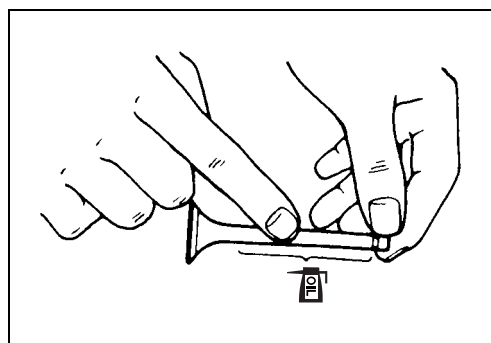

Install valve spring ④, and valve retainer ⑤.

**NOTE:**

*Set valve spring in place with narrow spiral area facing valve seat.*

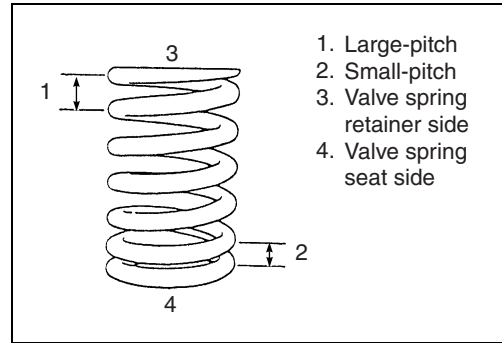

Hold valve spring compressed with special tool and install valve cotteners ⑥.

Make sure valve cotteners are properly seated in groove ①.

**TOOL** 09916-19030: Valve lifter  
09916-14521: Attachment  
09916-84511: Tweezers

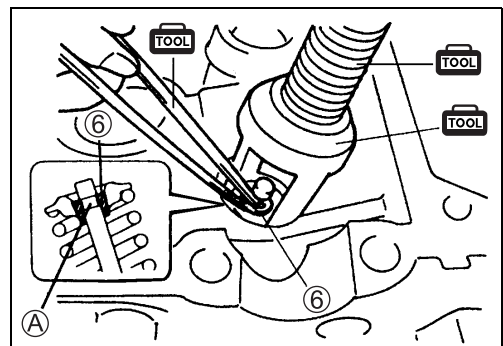
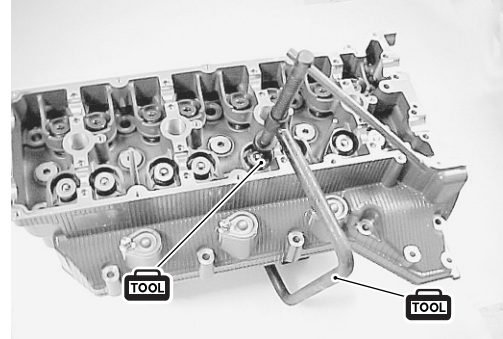

## COUNTER-BALANCER MECHANISM REMOVAL

Prior to removing counter-balancer mechanism assembly:

- Remove the power unit. (See page 6-15 to 6-20.)
- Remove the balancer chain. (See page 6-31 or 6-44.)

1. Remove bolts and water jacket cover ① (if necessary).

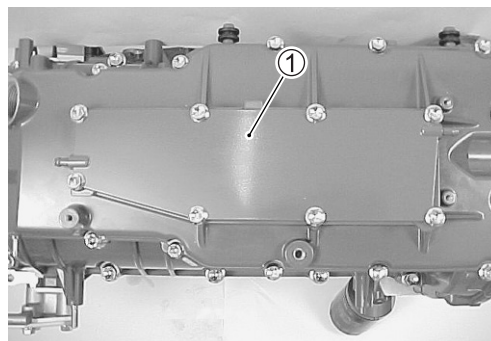

2. Remove the bolts securing balancer cover ② to crankcase, then remove balancer cover.

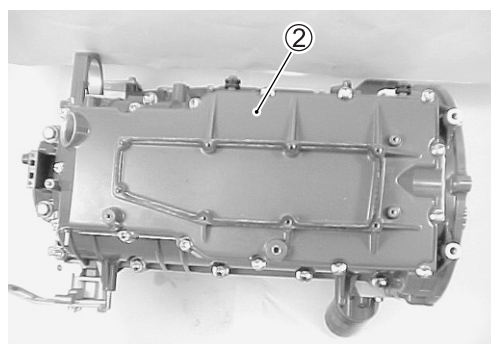

3. Remove the seven (7) bolts securing counter-balancer mechanism assembly ③ to crankcase, then remove counter-balancer mechanism assembly.

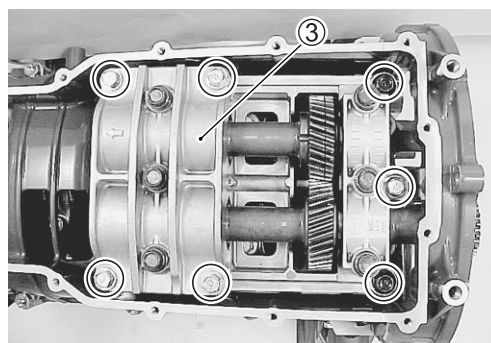

## DISASSEMBLY

1. Remove the three (3) bolts and upper housing ①.
2. Remove the three (3) bolts and lower housing ②.

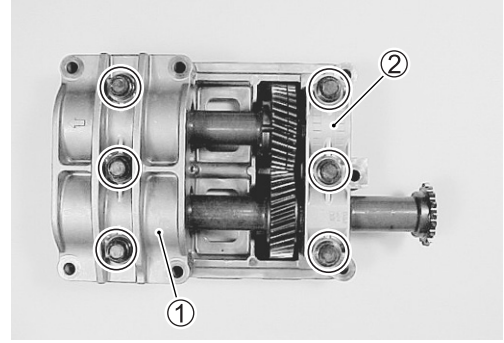

### NOTE:

Before removing STBD balancer shaft ③ and/or PORT balancer shaft ④, insert special tool (pin) through hole A on No.1 gear ⑤ and hole B on No.2 gear ⑥ as shown.

 09917-29610: Scissors gear alignment tool set

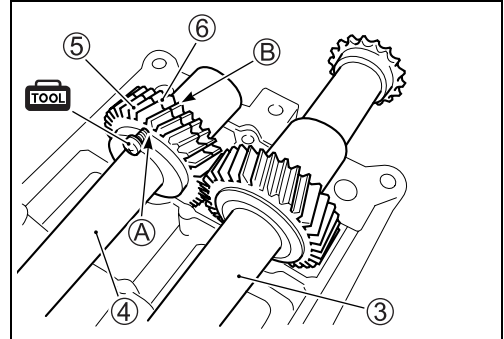

3. Remove STBD balancer shaft assembly ③.  
Remove PORT balancer shaft assembly ④.

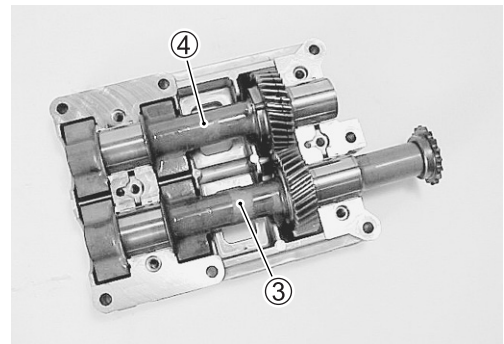

4. Remove circlip ⑦, washer ⑧ and No.2 gear ⑥.

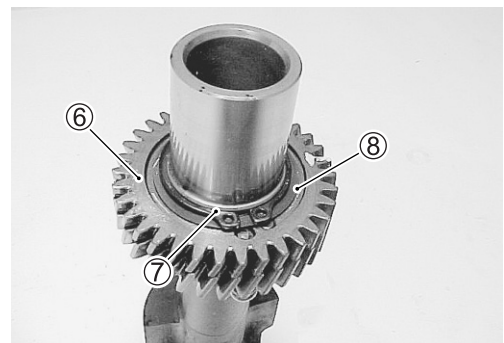

5. Remove scissors spring plate ⑨ from No.1 gear ⑤.

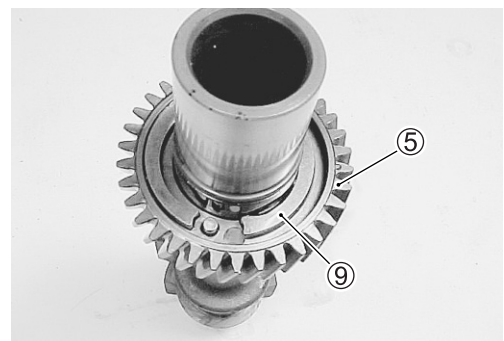



6. Secure STBD balancer shaft in a vise, then remove bolt ⑩, washer ⑪ and driven sprocket ⑫. Account for dowel pin ⑬.

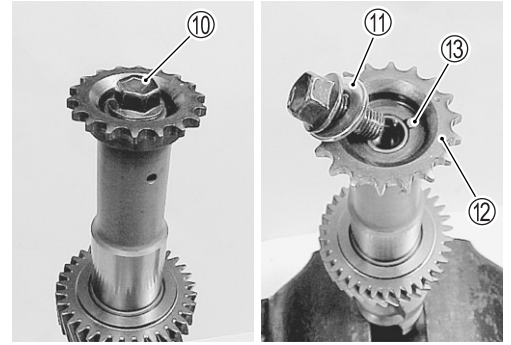

## INSPECTION

### NOTE:

*If any component is worn excessively, cracked, defective or damaged in any way, it must be replaced.*

### BALANCER GEAR

Inspect gears. Replace gear if damaged, worn excessively or other abnormal condition.

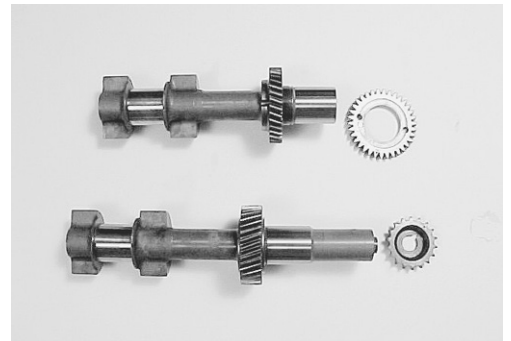

### BEARING

Check bearings for pitting, scratches, wear or damage.

If any improper condition is found, replace both upper and lower halves.

Always replace both bearing halves, never replace only one half of a bearing set.



### BALANCER SHAFT JOURNAL

Check balancer shaft journals for pitting, scratches, wear or damage.

If any of the above condition are found, replace balancer shaft.

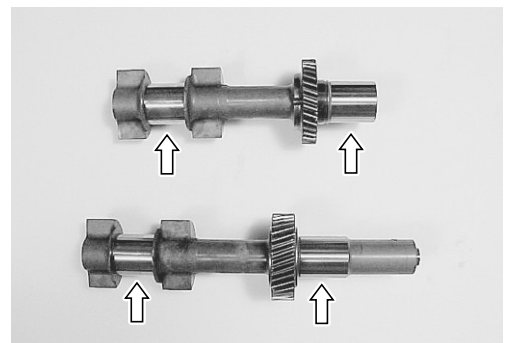

## HOUSING

Check base housing, upper housing and lower housing.  
If cracks or other damage are found, replace housings as a set.

### NOTE:

*Base housing, upper housing and lower housing must be replaced as a set.*

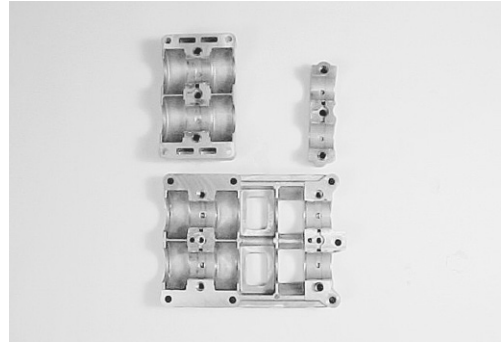

## ASSEMBLY

Assembly is reverse order of disassembly with special attention to the following steps.

1. Wash, clean and then dry all disassembled parts.
2. Put scissors spring plate ① onto No.1 gear ② as shown.
3. Install No.2 gear ③ on the PORT balancer shaft so that the pin ③ on No.2 gear contacts with end of scissors spring plate ①.  
Check that both scissors spring plate ends contact to pins ③ and ④ on each gear as shown.
4. Secure PORT balancer shaft in a vise.  
Turn the No.2 gear ③ counterclockwise by using special tool until hole ⑤ on No.1 gear ② aligns with hole ⑥ on No. 2 gear ③.

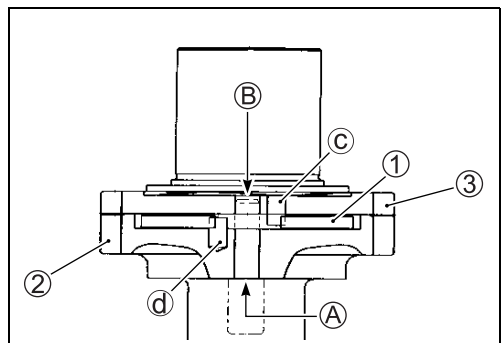
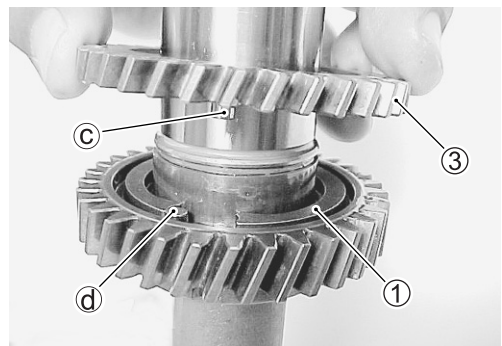
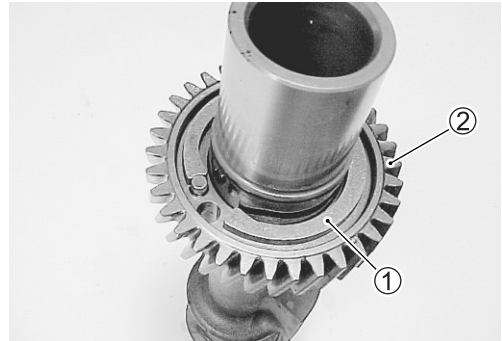

**TOOL** 09917-29610: Scissors gear alignment tool set

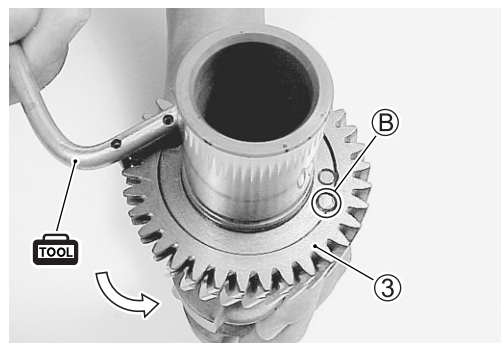

5. Insert special tool (pin) through hole **A** on No.1 gear **2** and hole **B** on No.2 gear **3** as shown.

 **09917-29610: Scissors gear alignment tool set**

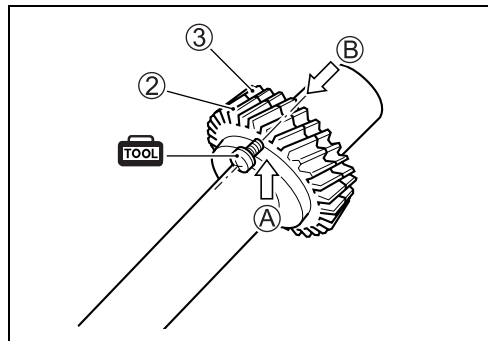

6. Install washer **4** and circlip **5**.

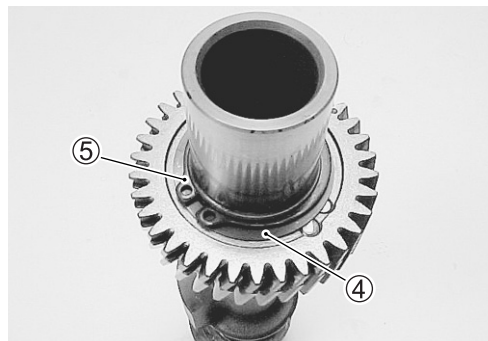

7. Secure STBD balancer shaft in a vise.  
Install dowel pin **6**, driven sprocket **7** and washer **8**, then tighten bolt **9** to specified torque.

 **Balancer driven sprocket: 48 N·m (4.8 kg-m, 34.7 lb-ft)**

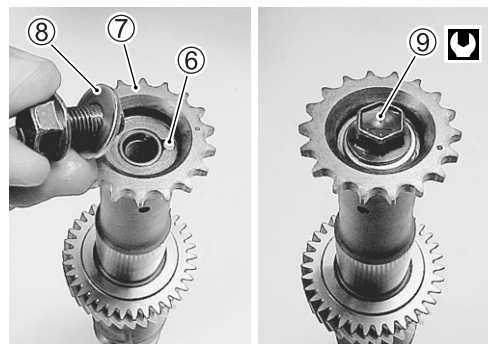

8. Install bearings **13** in base housing **10**, upper housing **11** and lower housing **12**.  
Apply molybdenum oil solution to each bearing.

 **MOLYBDENUM OIL SOLUTION**

Mix equal amounts of engine oil and SUZUKI MOLY PASTE (p/no, 99000-25140) in a ratio of 1:1

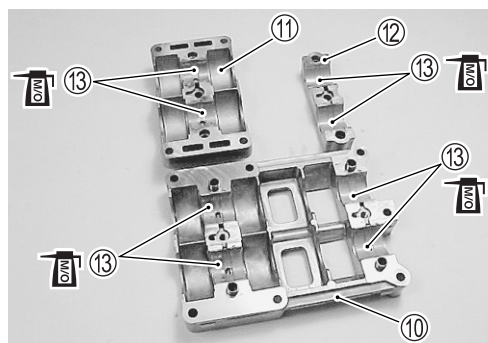

**NOTE:**

- Align bearing tab **a** with notch in each housing.
- Assemble each bearing in its original position.

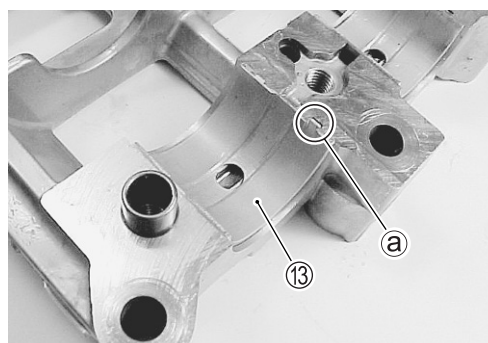

9. Apply molybdenum oil solution to balancer shaft journals.

### MOLYBDENUM OIL SOLUTION

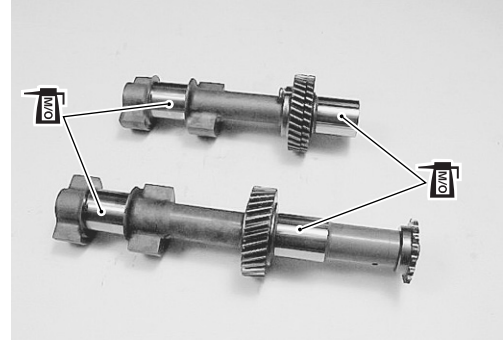

10. Install dowel pins ⑭.

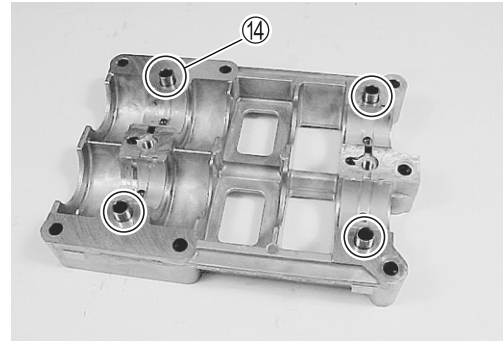

11. Install PORT balancer shaft assembly ⑮ in base housing.

12. Install STBD balancer shaft ⑯ in base housing so that match mark (•) on STBD balancer gear aligns with match mark (•) on No.2 PORT balancer gear as shown in illustration.

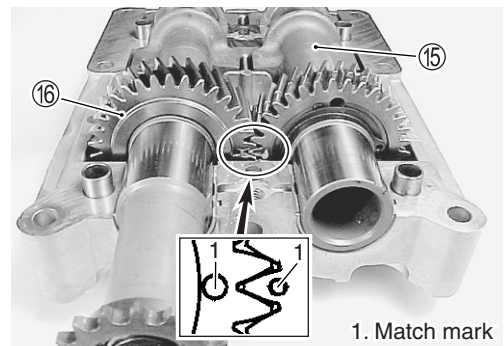

13. Install upper housing ⑪ to base housing ⑩ with arrow mark on upper housing toward flywheel side.  
Install lower housing ⑫ to base housing ⑩.

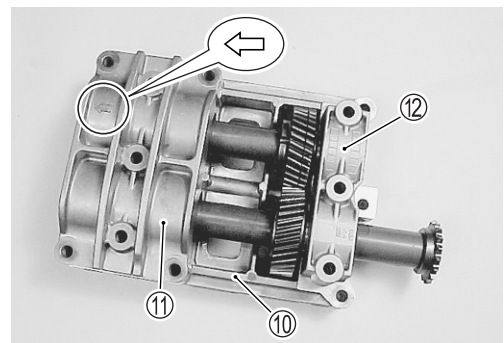

14. Apply engine oil to housing bolts.

15. Lightly seat all housing bolts at first.

Following sequence in figure, tighten bolts in 2-steps.  
Tighten bolts to 1/2 of specified torque, then to full specified torque.

 **Balancer housing bolt: 30 N·m (3.0 kg·m, 21.7 lb·ft)**

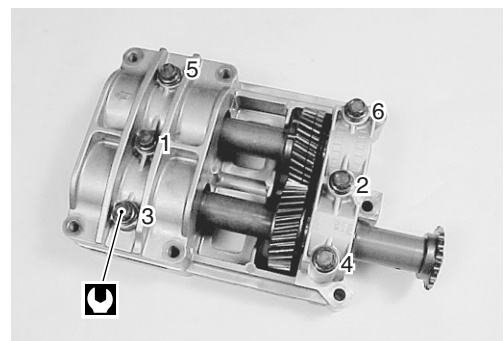



16. Remove the special tool (pin) from PORT balancer No.1 gear ② and No.2 gear ③.

 **09917-29610: Scissors gear alignment tool set**

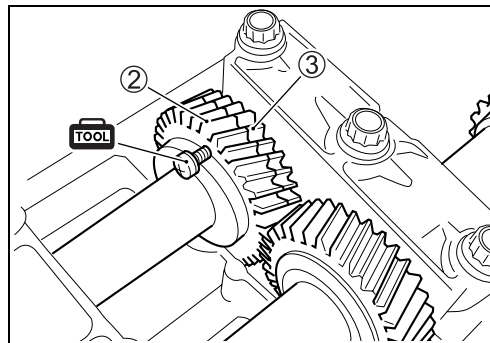

## INSTALLATION

Installation is reverse order of removal with special attention to the following steps.

### CAUTION

**Do not reuse gaskets. Always replace with new one.**

1. Insert the dowel pins ① and place counter-balancer mechanism assembly ② into position on the crankcase.

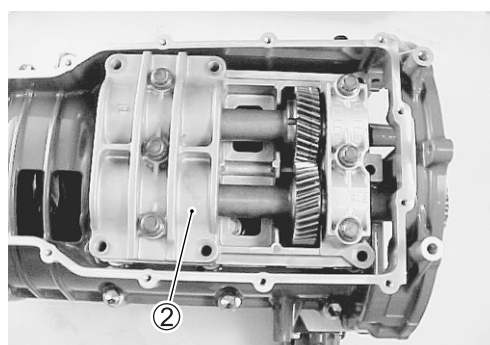
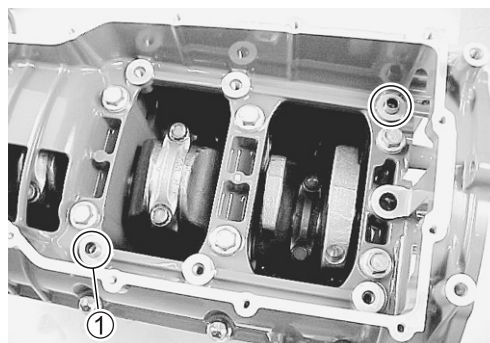

2. Apply engine oil to balancer housing bolts.
3. Lightly seat all balancer housing bolts at first. Following sequence in figure, tighten bolts in 3-steps. Tighten bolts to 1/3 of specified torque, then 2/3 of specified torque and finally to full specified torque.

 **Balancer mechanism mounting bolt:**  
25 N·m (2.5 kg-m, 18.1 lb-ft)

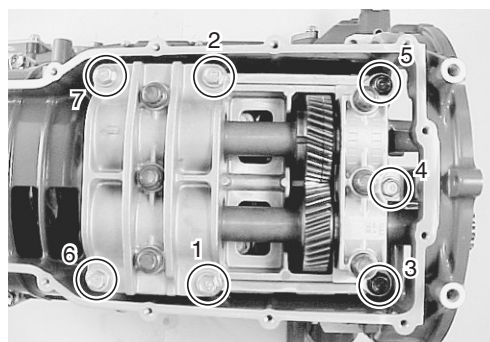



## CYLINDER/CRANKSHAFT/PISTON DISASSEMBLY

Before performing service work in this section:

- Remove power unit. (See page 6-15 to 6-20.)
- Remove timing chain and balancer chain.  
(See page 6-31 or 6-44.)
- Remove cylinder head. (See page 6-57.)
- Remove counter-balancer mechanism.  
(See page 6-75.)

Remove oil filter ①.

 09915-47341: Oil filter wrench

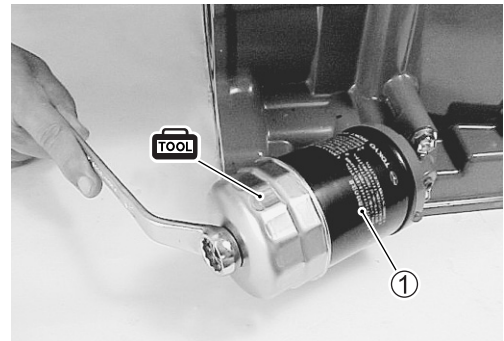

Remove the three (3) bolts securing oil filter housing ②, then remove oil filter housing ②.

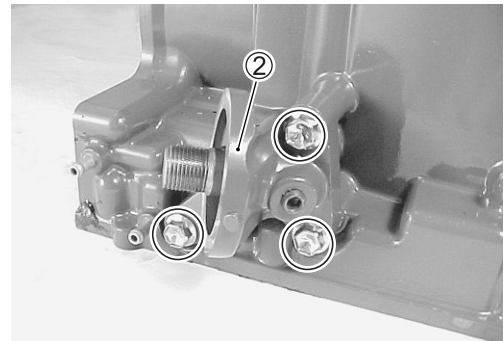

Remove oil pressure switch ③.

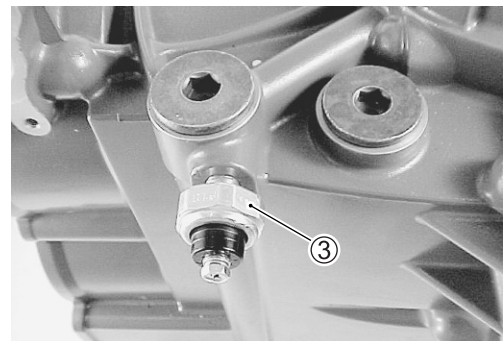

Remove ten (10) bolts ①.  
 Remove ten (10) bolts ②.  
 Remove crankcase from cylinder block.

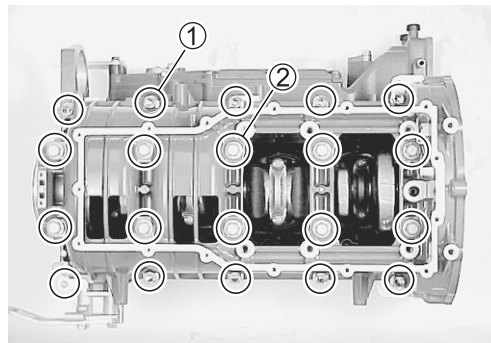

**NOTE:**

*For proper assembly, mark cylinder number on all pistons, conrods, and conrod caps, using quick drying paint.*

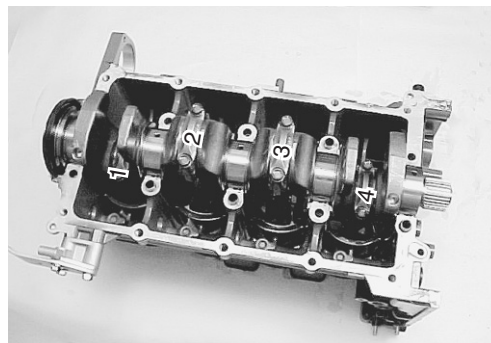

Remove all conrod cap bolts ① and conrod caps ②.

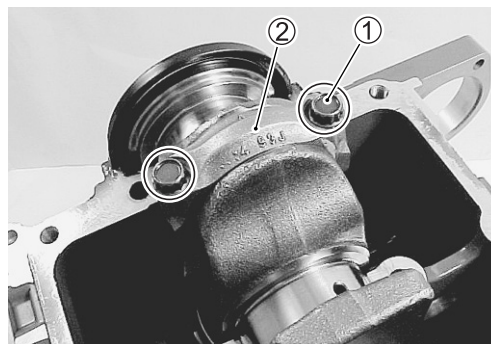

Remove crankshaft ③.  
 Remove oil seal ④ from crankshaft.

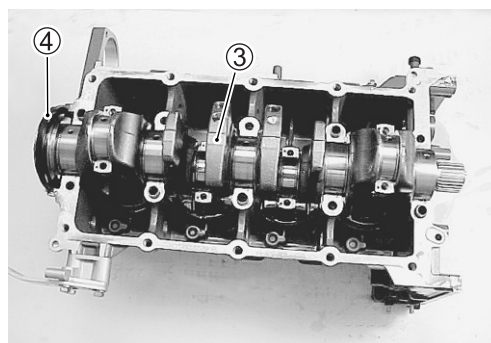

Mark cylinder number on pistons using quick dry paint.  
 Push piston (with conrod) out through the top of cylinder bore.

**NOTE:**

- *To prevent damage to piston rings, decarbon top of cylinder bore wall before removing piston.*
- *Reassemble each conrod cap to its original position after removing piston from bore.*

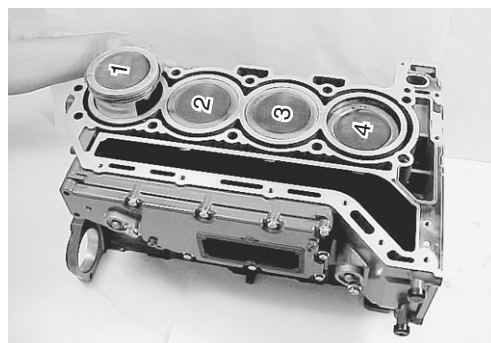

Remove two compression rings (top and 2nd) and oil ring from piston.

Mark cylinder number on conrod using quick dry paint.



Remove piston pin from piston and conrod using special tool and arbor press as shown.

**NOTE:**

- *The piston pin is press fit into conrod small end.*
- *Reassemble each piston, piston pin and conrod in their original combination and position.*

 **09910-39610: Piston pin remover & installer set**

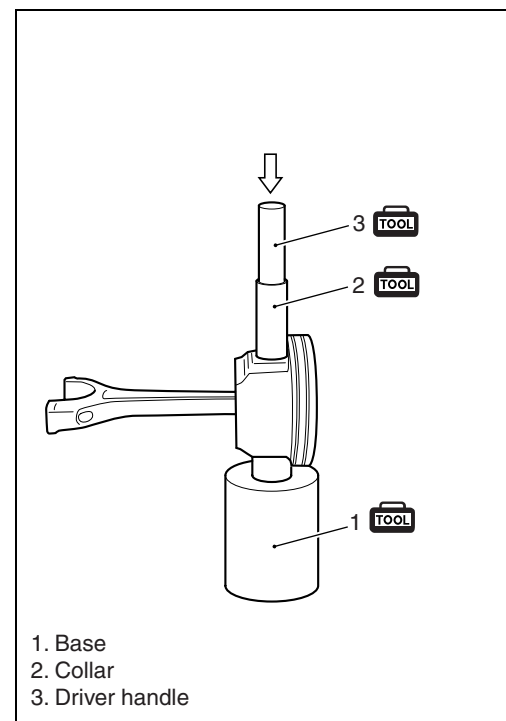
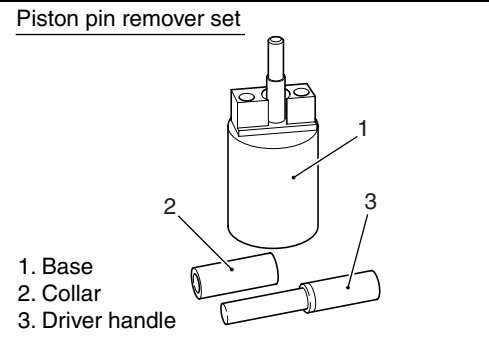

## INSPECTION/SERVICING

### NOTE:

If cracks, excessive wear or other damage is found on any component, replace component.

### CYLINDER

- **Cylinder distortion**

Using a straightedge and thickness gauge, measure cylinder distortion (gasket surface) at a total of six (6) locations as shown.

 **09900-20803: Thickness gauge**

#### Cylinder distortion

**Service limit: 0.03 mm (0.0011 in)**

If measurement exceeds service limit, resurface or replace cylinder.

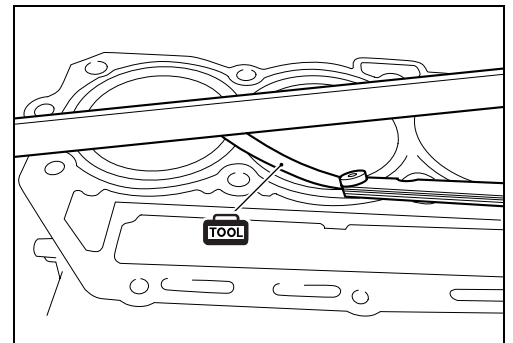
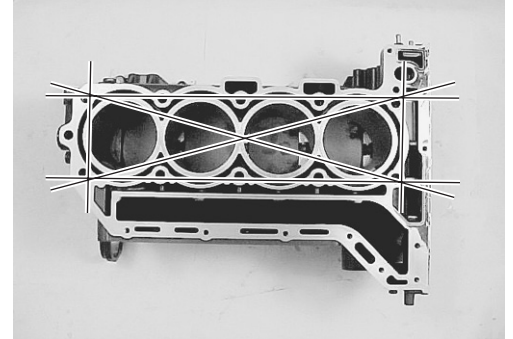

- **Water jackets**

Check water jackets.

If clog or obstruction is found, clean water jacket.

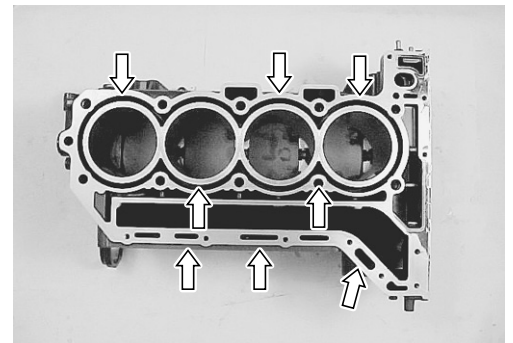

- **Driven gear bearing**

Inspect driven gear bearing. Replace bearing if pitted, noisy or rough.

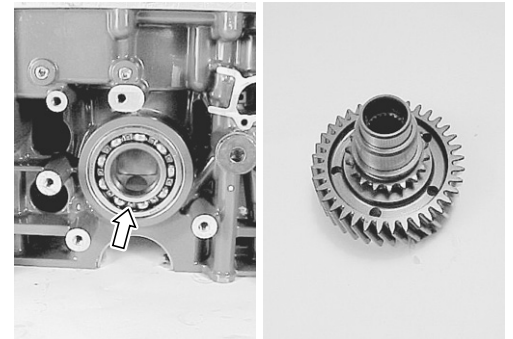

- **Cylinder bore**

Inspect cylinder walls for scratches, roughness, or ridges which indicate excessive wear.

If cylinder bore is very rough, deeply scratched or ridged, bore cylinder and use oversize piston.

- **Cylinder bore wear (difference)**

Using telescoping gauge, measure cylinder bore in both axial (vertical line, following crankshaft) and transverse (horizontal line across crankshaft) directions at two positions as shown in figure.

**NOTE:**

*Purchase a commercially available telescoping gauge for this measurement.*

Check for followings:

- Difference between measurements at the two positions (taper).
- Difference between axial and transverse measurement (out-of-round).

**Cylinder bore wear (difference)**

**Service limit: 0.10 mm (0.039 in)**

If measurement exceeds service limit, bore or replace cylinder.

**PISTON TO CYLINDER CLEARANCE**

(1) Measure the piston diameter at a point 9 mm (0.354 in) above the piston skirt at a right angle to the piston pin bore.

 **09900-20204: Micrometer**

**Piston skirt diameter**

**Standard: 96.905 – 96.925 mm (3.8152 – 3.8159 in)**

(2) Measure the cylinder bore at 50 mm (1.969 in) below the cylinder head gasket surface at a right angle to the crankshaft pin.

**NOTE:**

*Purchase a commercially available telescoping gauge for this measurement.*

**Cylinder bore diameter**

**Standard: 97.000 – 97.020 mm (3.8189 – 3.8197 in)**

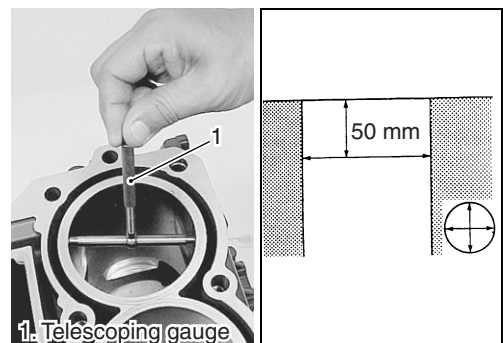
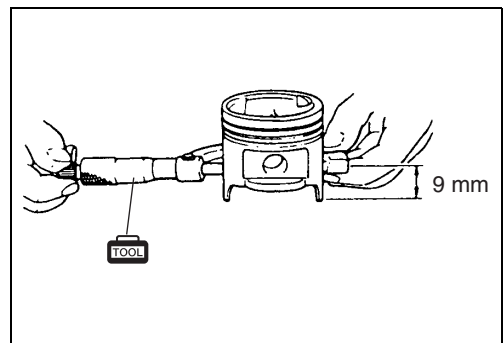
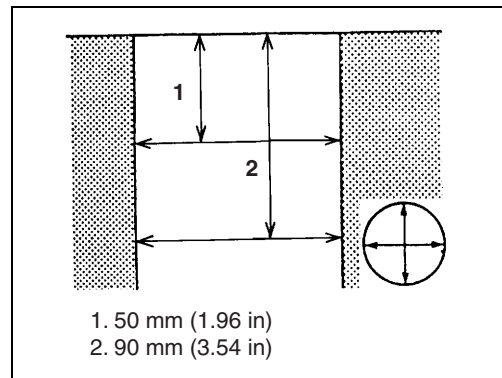
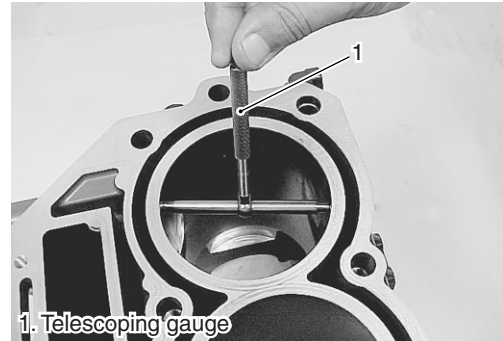



(3) Calculate the piston/cylinder clearance (Clearance equals difference between piston diameter and cylinder bore measurements).

**Piston to cylinder clearance**

**Standard: 0.085 – 0.105 mm (0.0033 – 0.0041 in)**

**Service limit: 0.150 mm (0.0059 in)**

If clearance exceeds service limit, replace piston and/or cylinder or bore cylinder.

**Identification of oversize piston/piston ring**

One oversize piston/piston ring components, 0.50 mm, is available.

Oversize piston/piston ring are marked as shown, below.

• **Piston**

Oversize	I.D. mark
0.50 mm	50

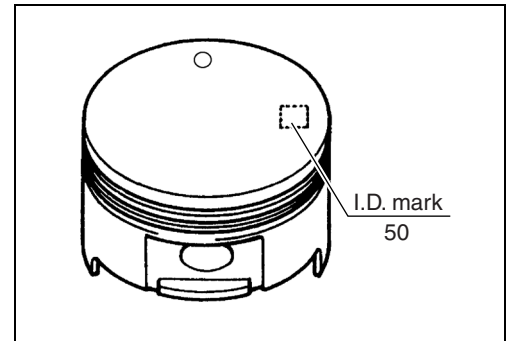

• **1st & 2nd Piston ring**

Oversize	I.D. mark
0.50 mm	50

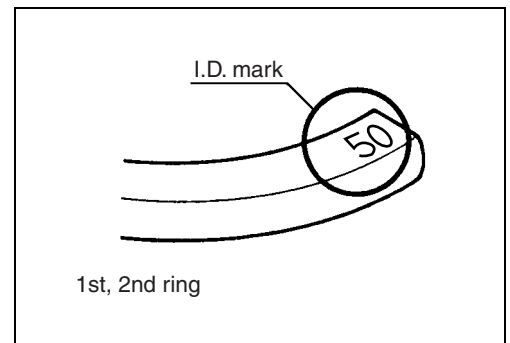

• **Oil ring**

Oversize	I.D. mark
0.50 mm	One (1) Red paint

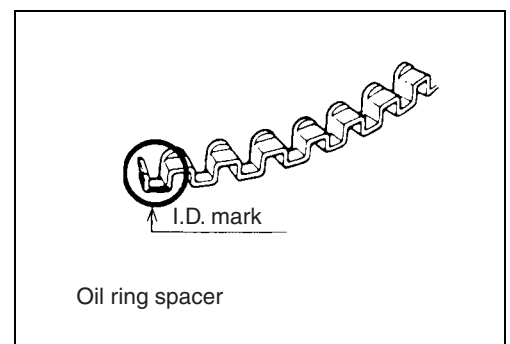

**PISTON**

- Inspect piston for faults, cracks or other damage. Damaged or faulty piston(s) should be replaced.

- **Piston ring to groove clearance**

Before checking, piston grooves must be clean, dry and free of carbon.

Fit piston ring into piston groove, and measure clearance between ring and ring groove using thickness gauge.

**TOOL 09900-20803: Thickness gauge**

**Piston ring to groove clearance****Standard:**

1st 0.030 – 0.070 mm (0.0012 – 0.0028 in)

2nd 0.020 – 0.060 mm (0.0008 – 0.0024 in)

**Service limit:**

1st 0.12 mm (0.0047 in)

2nd 0.10 mm (0.0039 in)

If measurement exceeds service limit, replace piston and/or piston ring.

**Piston ring groove width****Standard:**

1st 1.22 – 1.24 mm (0.0480 – 0.0488 in)

2nd 1.21 – 1.23 mm (0.0476 – 0.0484 in)

Oil 2.51 – 2.53 mm (0.0988 – 0.0996 in)

**Piston ring thickness****Standard:**

1st 1.17 – 1.19 mm (0.0461 – 0.0469 in)

2nd 1.17 – 1.19 mm (0.0461 – 0.0469 in)

**PISTON RING****Piston ring end gap**

Measure piston ring end gap with piston ring in the lowest position of cylinder bore.

**TOOL 09900-20803: Thickness gauge**

**Piston ring end gap****Standard:**

1st 0.20 – 0.30 mm (0.0079 – 0.0118 in)

2nd 0.30 – 0.45 mm (0.0118 – 0.0177 in)

**Service limit:**

1st 0.70 mm (0.0276 in)

2nd 1.00 mm (0.0394 in)

If measurement exceeds service limit, replace piston ring.

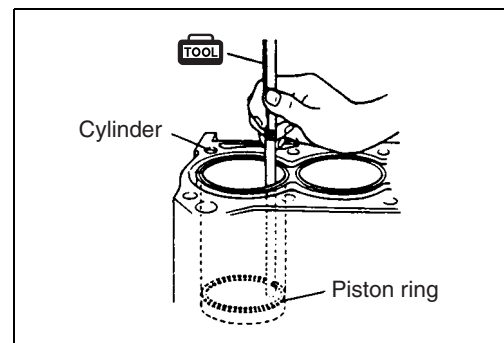
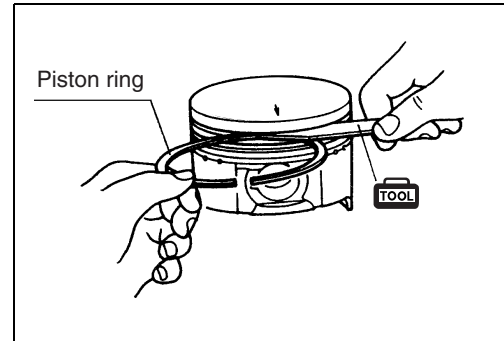

**Piston ring free end gap**

Measure piston ring free end gap using vernier calipers.

 **09900-20101: Vernier calipers**

**Piston ring free end gap****Standard:**

1st Approx. 13.5 mm (0.5315 in)

2nd Approx. 13.6 mm (0.5354 in)

**Service limit:**

1st 10.8 mm (0.4252 in)

2nd 10.9 mm (0.4291 in)

If measurement exceeds service limit, replace piston ring.

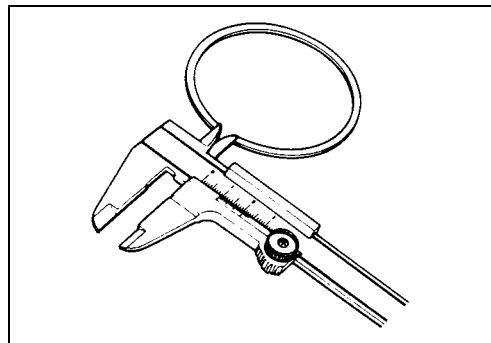
**PISTON PIN/PISTON PIN HOLE/CONROD SMALL END BORE**

- Check piston pin, conrod small end bore and piston pin hole for wear or damage.

If badly worn or damaged, replace component.

- Apply engine oil on piston pin so that the piston pin can move smoothly in the piston pin hole.

If improper condition is found, replace the piston pin and/or piston.

- Measure the following item:

 **09900-20205: Micrometer**

**09900-20605: Dial calipers**

**Piston pin outside diameter**

Standard: 21.995 – 22.000 mm (0.8659 – 0.8661 in)

**Piston pin hole diameter**

Standard: 22.006 – 22.014 mm (0.8664 – 0.8667 in)

**Conrod small end bore**

Standard: 21.968 – 21.979 mm (0.8649 – 0.8653 in)

**NOTE:**

*The piston pin is press-fit into the conrod small end bore.*

*There must be a negative clearance between the piston pin outside diameter and conrod small end inner diameter.*

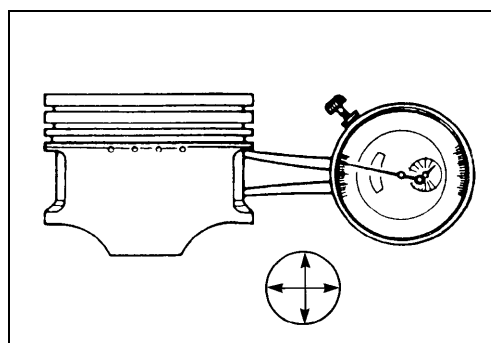
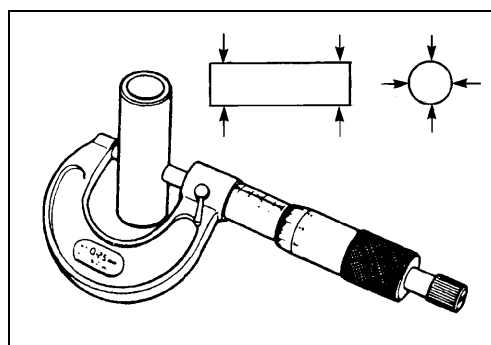

If measurement is out of specification, replace.

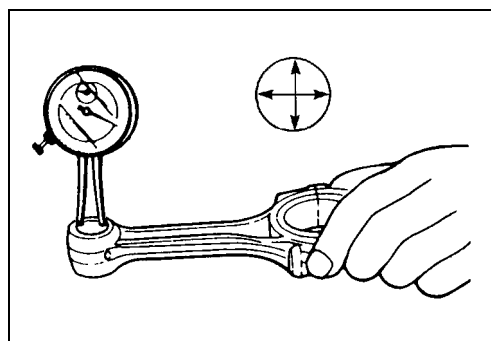

**CONROD BIG END SIDE CLEARANCE**

Measure conrod big end side clearance with conrod installed on crank pin as shown.

 **09900-20803: Thickness gauge**

**Conrod big end side clearance**

**Standard: 0.300 – 0.450 mm (0.0118 – 0.0177 in)**

**Service limit: 0.550 mm (0.0217 in)**

If measurement exceeds service limit, replace conrod and/or crankshaft.

**Conrod big end width**

**Standard: 22.750 – 22.800 mm (0.8957 – 0.8976 in)**

**Crank pin width**

**Standard: 23.100 – 23.200 mm (0.9094 – 0.9134 in)**

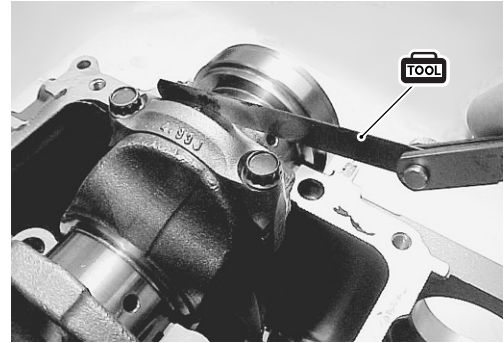
**CRANK PIN**

Inspect crank pin for uneven wear or damage.

Measure crank pin for out-of-round or taper with micrometer.

If crank pin is damaged, out-of-round or taper is out of service limit, replace crankshaft.

 **09900-20203: Micrometer**

Out-of-round :  $A - B$

Taper :  $a - b$

**Out-of-round and taper**

**Service limit: 0.010 mm (0.0004 in)**

**Crank pin diameter**

**Standard: 53.982 – 54.000 mm (2.1253 – 2.1260 in)**

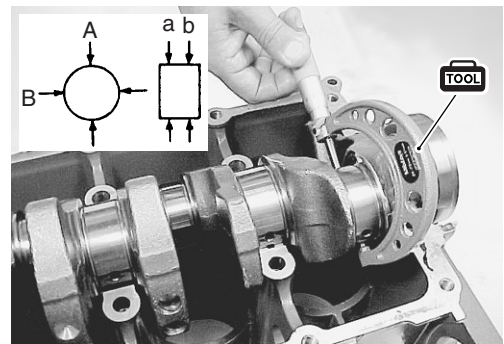
**CONROD BEARING**

Inspect bearing shell for proper contact pattern and signs of fusion, pitting, burning or flaking.

Bearing shells found in defective condition must be replaced.

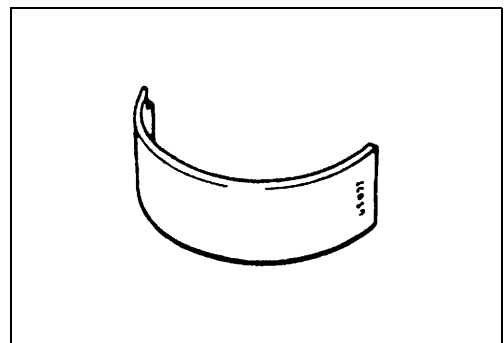
**Conrod big end oil clearance**

Check conrod big end oil clearance as follows;

- (1) Clean surface of conrod, conrod cap, conrod bearing, and crank pin.
- (2) Install conrod bearing onto conrod and conrod cap.

**NOTE:**

- Reassemble each bearing and conrod cap to their original position.
- Do not apply oil to bearing.

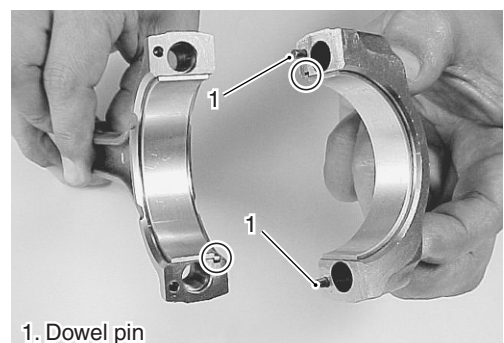

- (3) Place a piece of Plastigauge on crank pin parallel to crankshaft. Avoid placing Plastigauge over oil hole.

 **09900-22301: Plastigauge**

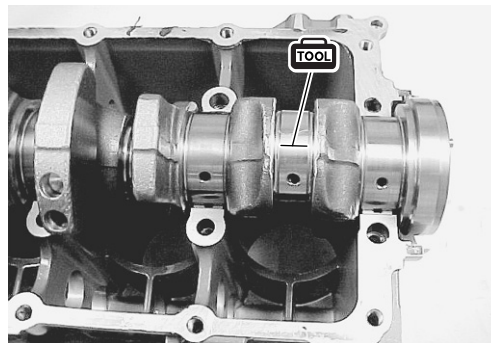

- (4) Install conrod cap (with bearing) to conrod with the arrow mark on cap toward flywheel side.

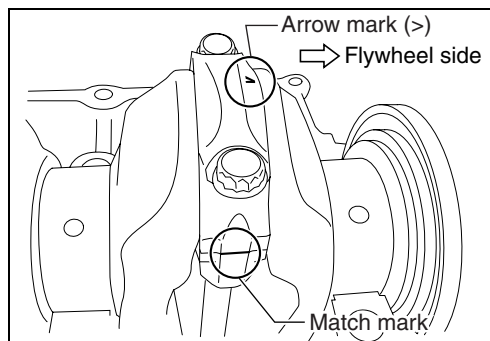

- (5) Apply engine oil to conrod bolts and tighten bolt in two steps.

 **Conrod cap bolt:**

**1st step 31 N·m (3.1 kg·m, 22.4 lb·ft)**

**Final step 63 N·m (6.3 kg·m, 45.6 lb·ft)**

**NOTE:**

*Do not rotate conrod with Plastigauge in place.*

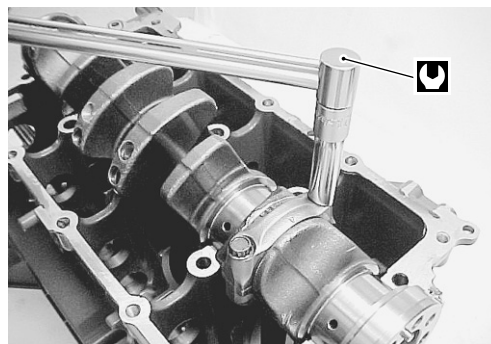

- (6) Remove conrod and conrod cap from crank pin.  
 (7) Using scale on Plastigauge envelope, measure Plastigauge width at its widest point.

**Conrod big end oil clearance**

**Standard: 0.045 – 0.063 mm (0.0018 – 0.0025 in)**

**Service limit: 0.080 mm (0.0031 in)**

If measurement exceeds service limit, replace conrod bearing.

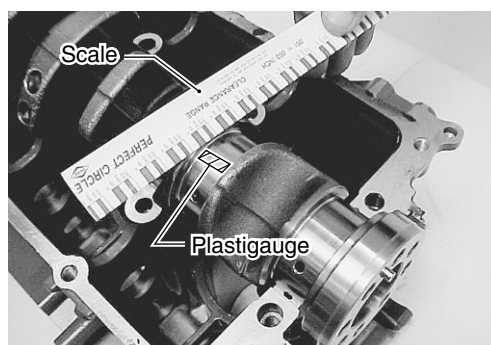

## CRANKSHAFT

### ■ Crankshaft runout

Using a dial gauge, measure runout at center journal.

 **09900-20606: Dial gauge**

**09900-20701: Magnetic stand**

**Crankshaft runout**

**Service limit: 0.04 mm (0.0016 in)**

If measurement exceeds service limit, replace crankshaft.

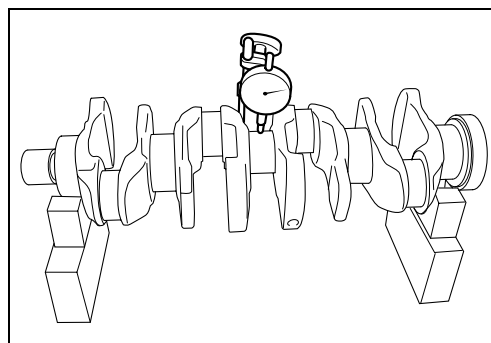



### ■ Crankshaft thrust play

Measure thrust play with crankshaft, thrust bearing, journal bearing and crankcase/cylinder block assembled in a normal manner.

Tighten crankcase bolts to specified torque.

#### Crankcase bolt:

**Outside (10 mm) 37 N·m (3.7 kg-m, 26.8 lb-ft)**

**Inside (11 mm) 58 N·m (5.8 kg-m, 41.9 lb-ft)**

Use a dial gauge to read displacement in axial (thrust) direction of crankshaft.

#### **Crankshaft thrust play**

**Standard: 0.11 – 0.31 mm (0.0043 – 0.0122 in)**

**Service limit: 0.35 mm (0.0138 in)**

If measurement exceeds service limit, replace crankshaft thrust bearing.

#### **Crankshaft thrust bearing thickness**

**Standard: 2.425 – 2.475 mm (0.0955 – 0.0974 in)**

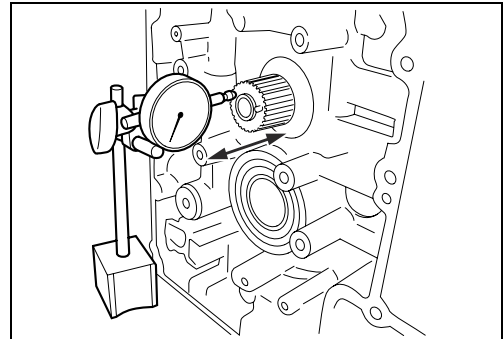

### ■ Out-of-round and taper (uneven wear) of journals

An unevenly worn crankshaft journal shows up as a difference in diameter at a cross section or along its length (or both).

This difference, if any, is determined by taking micrometer readings.

If any journal is badly damaged or if measurements exceed service limit, replace crankshaft.

#### 09900-20203: Micrometer

Out-of-round:  $A - B$

Taper :  $a - b$

#### **Out-of-round and taper**

**Service limit: 0.010 mm (0.0004 in)**

#### **Crankshaft journal outside diameter**

**Standard: 64.982 – 65.000 mm (2.5583 – 2.5591 in)**

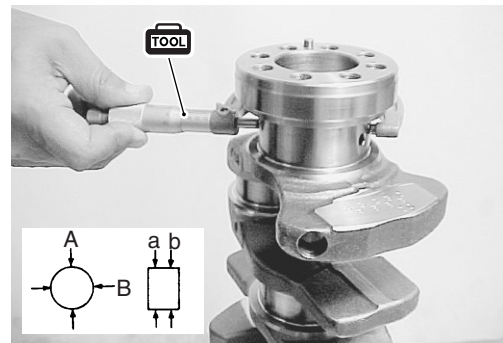

### **CRANKSHAFT MAIN BEARING**

Check bearings for pitting, scratches, wear or damage.

If any improper condition is found, replace both upper and lower halves.

Always replace both bearing halves, never replace only one half of a bearing set.

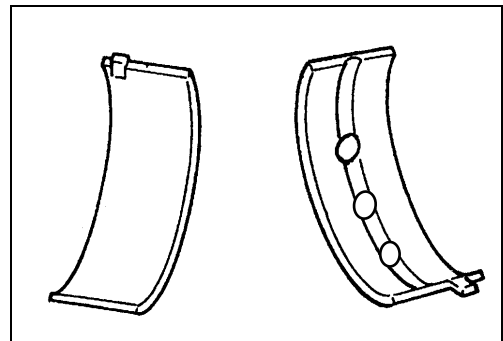

## CRANKSHAFT JOURNAL OIL CLEARANCE

Check clearance using Plastigauge according to the following procedure.

### NOTE:

Assemble each bearing in its original position before checking clearance.

(1) Clean surface of bearing holder (crankcase, and cylinder), bearing, and main bearing journal.

(2) Install main bearing to cylinder and crankcase.

### NOTE:

- Align tab **@** of bearing with notch in cylinder and crankcase.
- Do not apply engine oil to bearing.
- Install lower bearing half with oil hole/groove towards cylinder side.

(3) Install crankshaft to cylinder.

(4) Place a piece of Plastigauge across full width of bearing (parallel to crankshaft) on journal.

Do not place Plastigauge over oil hole.

**TOOL** 09900-22301: Plastigauge

### NOTE:

Do not rotate crankshaft while Plastigauge is installed.

(5) Assemble crankcase to cylinder.

(6) Apply engine oil to crankcase bolts.

Tighten crankcase bolts in three (3) steps following the order indicated below.

### NOTE:

Tighten 11 mm (0.433 in) thread diameter bolts first (following the order shown in figure), then tighten 10 mm (0.394 in) thread diameter bolts.

**U** Crankcase inside bolt (11 mm thread diameter):

1st step 11 N-m (1.1 kg-m, 8.0 lb-ft)

2nd step 46 N-m (4.6 kg-m, 33.3 lb-ft)

Final step 58 N-m (5.8 kg-m, 41.9 lb-ft)

**U** Crankcase outside bolt (10 mm thread diameter):

1st step 10 N-m (1.0 kg-m, 7.2 lb-ft)

2nd step 30 N-m (3.0 kg-m, 21.7 lb-ft)

Final step 37 N-m (3.7 kg-m, 26.8 lb-ft)

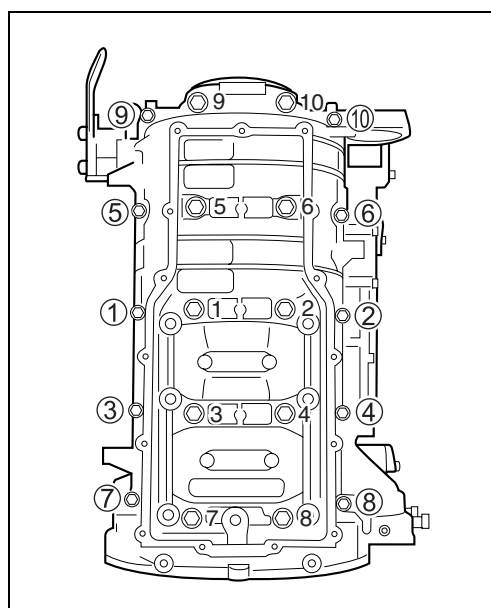
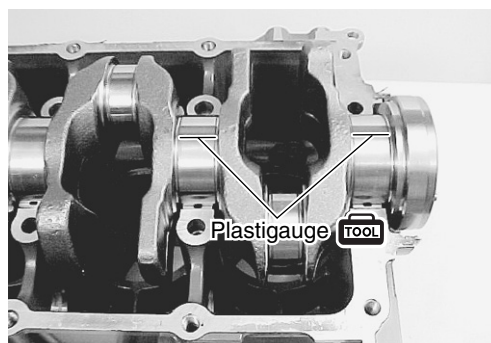
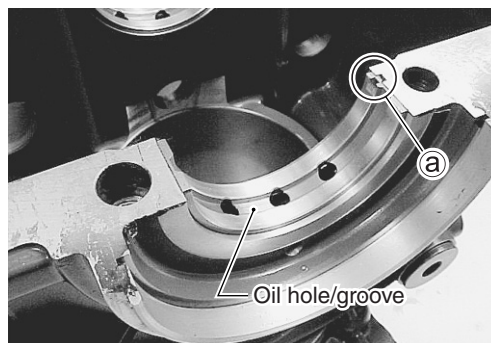
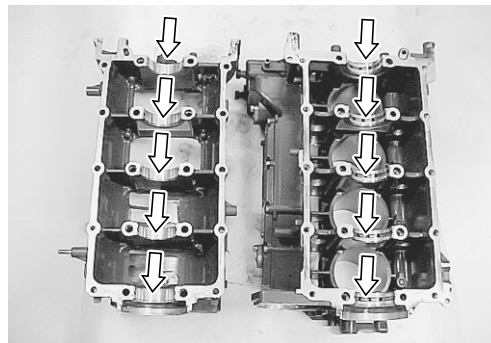

**NOTE:**

Crankcase must be torqued to specification in order to assure proper compression of Plastigauge and accurate reading of clearance.

- (7) Remove crankcase from cylinder.
- (8) Using scale on Plastigauge envelope, measure Plastigauge width at its widest point.

**Crankshaft journal oil clearance**

**Standard: 0.030 – 0.050 mm (0.0012 – 0.0020 in)**

**Service limit: 0.065 mm (0.0026 in)**

If measurement exceeds service limit, replace crankshaft main bearing.

**NOTE:**

For bearing replacement, see the “SELECTION OF MAIN BEARING” section on page 6-95.

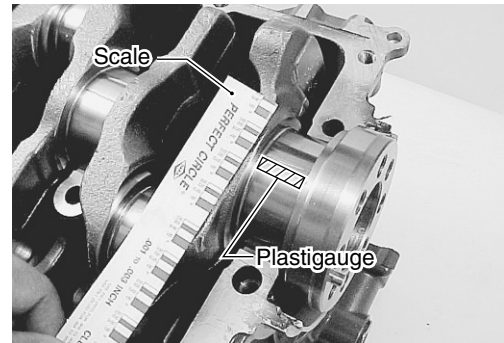
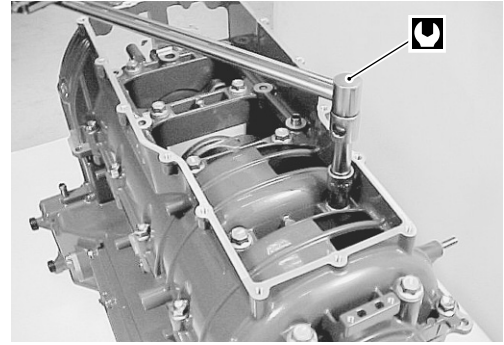

## SELECTION OF MAIN BEARING

Whenever a bearing requires replacement, select a new bearing according to following procedure.

### (1) First, check journal diameter.

As shown in figure, upper (flywheel side) crank web of No.1 cylinder has five (5) stamped code numerals.

The numerals (1, 2 & 3) represent the journal diameters shown below.

Numeral stamped	Journal diameter
1	64.994 – 65.000 mm (2.5588 – 2.5591 in)
2	64.988 – 64.994 mm (2.5586 – 2.5588 in)
3	64.982 – 64.988 mm (2.5583 – 2.5586 in)

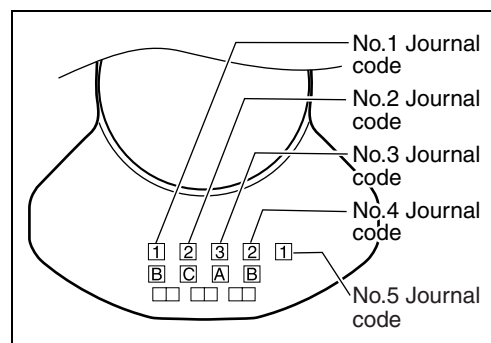

### (2) Next, check bearing holder inside diameter without bearing.

As shown in figure, the cylinder block PORT side has five (5) stamped code letters.

The letters (A, B & C) represent the bearing holder inside diameters shown below.

Code	Crank bearing holder inside diameter (w/o bearing)
A	70.000 – 70.006 mm (2.7559 – 2.7561 in)
B	70.006 – 70.012 mm (2.7561 – 2.7564 in)
C	70.012 – 70.018 mm (2.7564 – 2.7566 in)

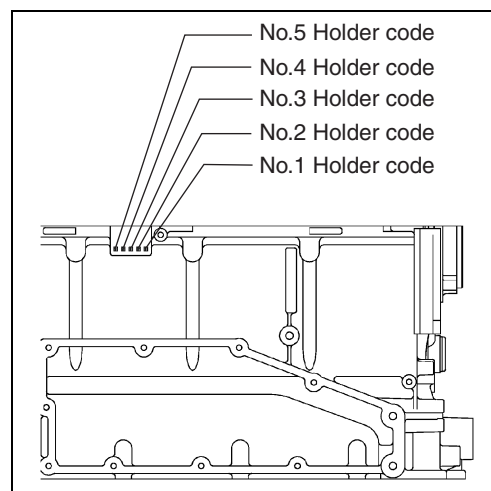

### (3) There are five (5) main bearings available, each of differing thickness.

To distinguish them, a color mark is painted at the position indicated in figure.

Each color represents the following thickness measured at the center of the bearing.

Color mark	Bearing thickness
Black	2.496 – 2.500 mm (0.0983 – 0.0984 in)
No color mark	2.499 – 2.503 mm (0.0984 – 0.0985 in)
Yellow	2.502 – 2.506 mm (0.0985 – 0.0987 in)
Blue	2.505 – 2.509 mm (0.0986 – 0.0988 in)
Pink	2.508 – 2.512 mm (0.0987 – 0.0989 in)

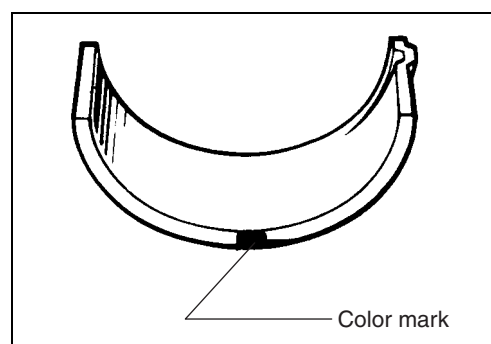

(4) Select crankshaft main bearing referring the below table.

		Numeral stamped on crank web (journal outside diameter)		
		1	2	3
Code stamped on cylinder block (Bearing holder inside diameter)	A	Black	No color	Yellow
	B	No color	Yellow	Blue
	C	Yellow	Blue	Pink

**NOTE:**

Measure crankshaft journal oil clearance again after installing new bearing selected. (See page 6-93.)

**CRANKSHAFT DRIVE GEAR**

Inspect drive gear. Replace gear if damaged or worn.



**OIL SEAL**

Inspect condition. If cracked, cut or damaged, replace.



**SEAL RING**

Inspect seal ring.

Replace if worn, nicked, cut or other abnormal condition.





## REASSEMBLY

Assembly is reverse order of disassembly paying special attention to the following steps.

### CAUTION

If original components are not replaced, each piston, piston pin and conrod is to be assembled and installed in its original order and position.

### PISTON TO CONROD

Apply engine oil to piston pin ①, piston pin bore and conrod ②. Assemble conrod ② to piston ③ as shown in figure.

#### NOTE:

- "96J" mark on conrod and up mark (○) on piston dome must face toward flywheel side.

Use special tool and arbor press shown in figure.

Press fit the piston pin ① to conrod (with piston) until the line (A) on driver handle is flush with the flat surface of piston.

 **09910-39610: Piston pin remover & installer**

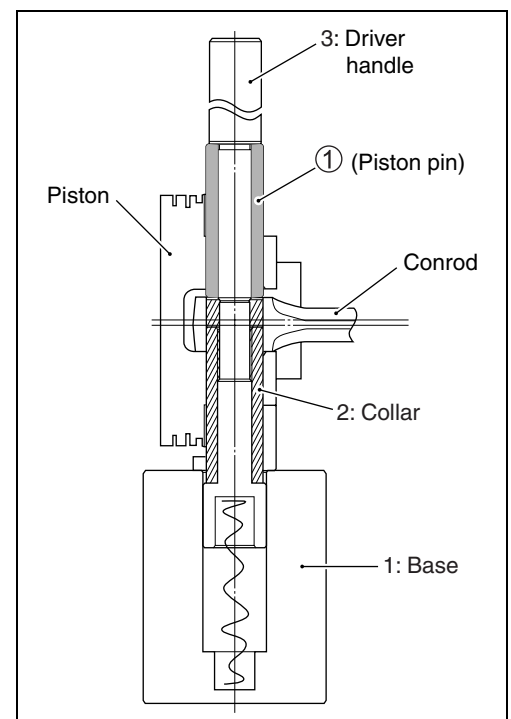
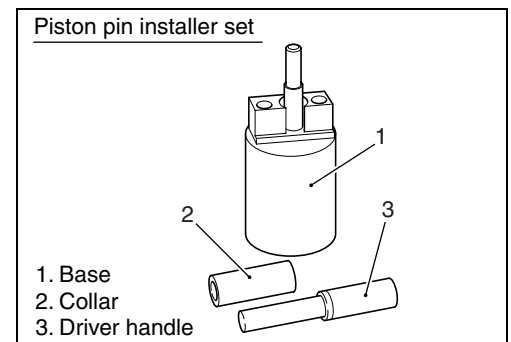
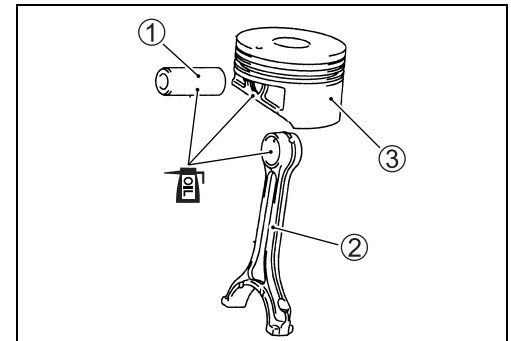
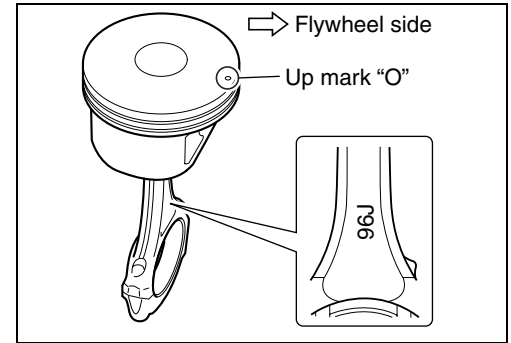

**PISTON RING TO PISTON**

**Oil ring**

- Apply engine oil to piston rings.
- Install spacer ① first, then side rails ② to piston.

**CAUTION**

When installing spacer, do not allow spacer ends to overlap in groove.

**1st and 2nd piston ring**

- Apply engine oil to piston ring.
- Install 2nd ring and 1st ring to piston.

**NOTE:**

- 1st and 2nd ring differ in shape and color as shown in figure.
- Also indicated in figure, the 1st and 2nd ring are marked with the letter "R" which must face towards top of piston.

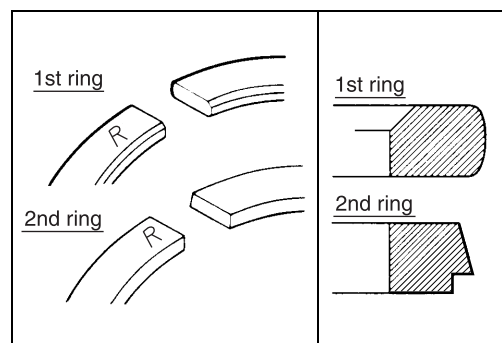
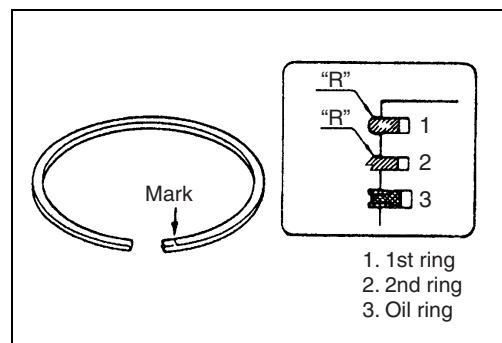
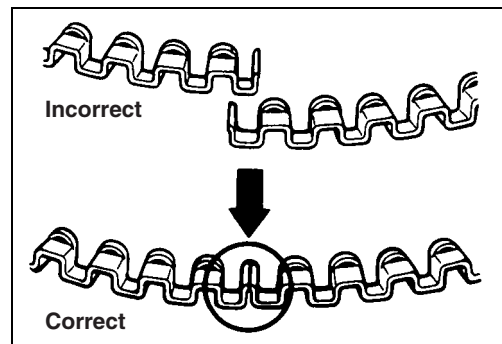
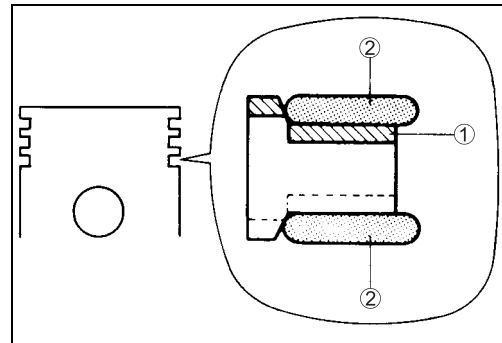
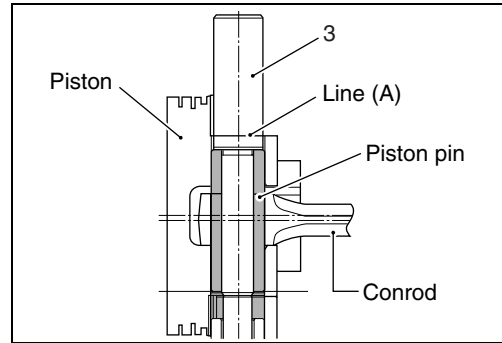

**Ring gap direction**

Position piston rings so gaps are staggered at approximately 90 degree angles as shown.

- ① 1st ring                      ③ 2nd ring  
 ② Oil ring lower side rail   ④ Oil ring upper side rail

**CAUTION**

**Failure to stagger piston ring gaps may result in crankcase oil dilution.**

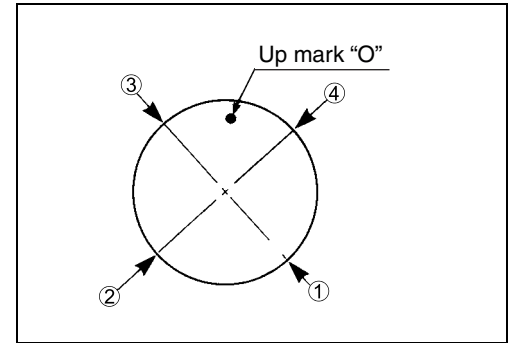
**PISTON TO CYLINDER**

Install conrod bearing to conrod and conrod cap.

**CAUTION**

- Assemble each conrod bearing to its original position.
- Do not apply oil between conrod and bearing or between bearing cap and bearing.

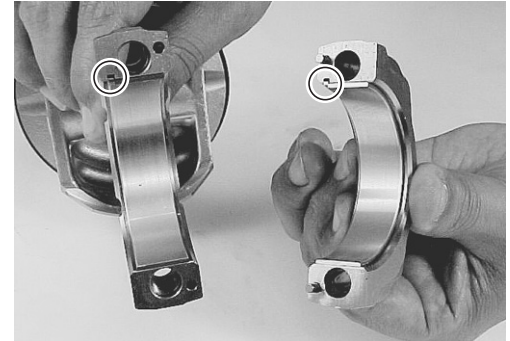

Apply engine oil to piston and cylinder walls.

Insert piston and conrod assembly into cylinder bore from cylinder head side using special tool.

**TOOL** 09916-77310: Piston ring compressor

**NOTE:**

Position the "circle" mark (○) on piston head to flywheel side.

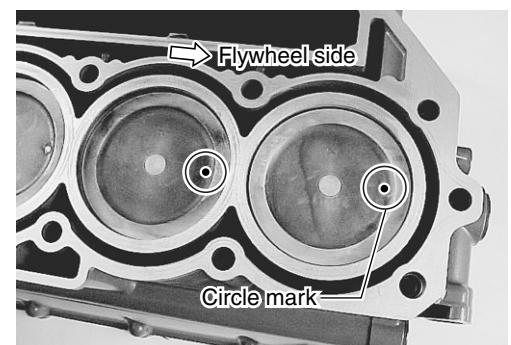

**CRANKSHAFT TO CYLINDER**

Install crankshaft main bearings in cylinder and crankcase.  
Apply molybdenum oil solution to bearings.

**MOLYBDENUM OIL SOLUTION**

Mix equal amounts of engine oil and SUZUKI MOLY PASTE (P/no. 99000-25140) in a ratio of 1:1.

**CAUTION**

- Assemble each bearing to its original position.
- Assemble main bearing half containing oil groove/hole to cylinder block.  
Assemble the half without oil groove to crankcase.
- Do not apply MOLYBDENUM OIL SOLUTION between crank bearing holder and crank main bearing.

**NOTE:**

Align bearing tab @ with notch in cylinder and crankcase.

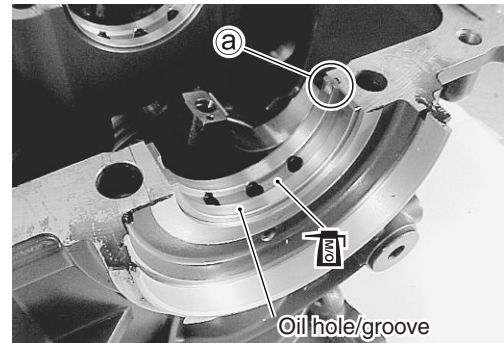
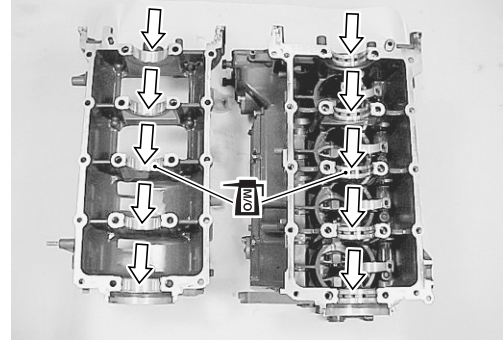
**Thrust bearing**

Apply molybdenum oil solution to the thrust bearing and install in cylinder block overlapping both sides of the No.4 main journal.  
Oil groove on the thrust bearing must face towards crank webs.

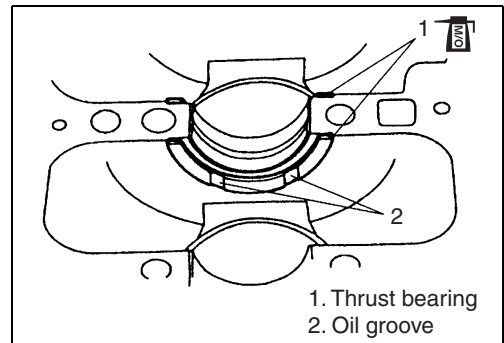
**MOLYBDENUM OIL SOLUTION****Crankshaft drive gear**

To assemble the drive gear on crankshaft, align the dot (•) mark on drive gear with the dowel pin hole on crankshaft.

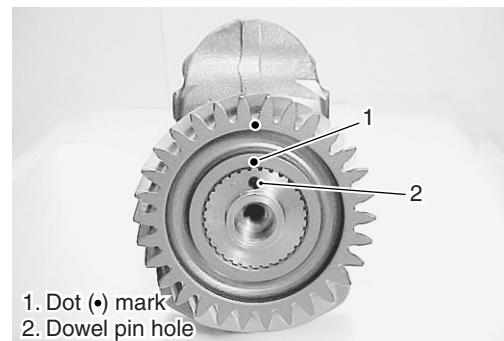

**Crankshaft**

Apply engine oil to upper oil seal lip.  
Install upper oil seal to crankshaft.

**CAUTION**

**Do not reuse seal removed. Be sure to use new seal.**

**NOTE:**

*Install upper oil seal with its spring/lipped side facing inward.*

Apply molybdenum oil solution to crank pin and crankshaft main journal and install crankshaft in cylinder.

**NOTE:**

*When installing crankshaft to cylinder, be sure to fit tab of seal in groove of cylinder.*

**MOLYBDENUM OIL SOLUTION****CONROD CAP**

Apply molybdenum oil solution to crank pin and conrod bearing.  
Install dowel pins and conrod cap (with bearing) to conrod with arrow mark on cap toward flywheel side.

**CAUTION**

**Reassemble each conrod cap to its original position.**

**MOLYBDENUM OIL SOLUTION**

Apply engine oil to conrod bolts.  
Tighten conrod cap bolts in two steps.

**Conrod cap bolt:**

**1st step 31 N·m (3.1 kg-m, 22.4 lb-ft)**

**Final step 63 N·m (6.3 kg-m, 45.6 lb-ft)**

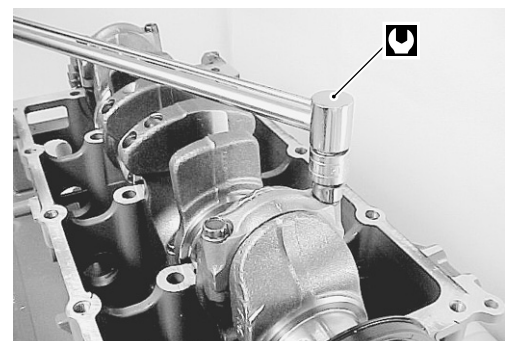
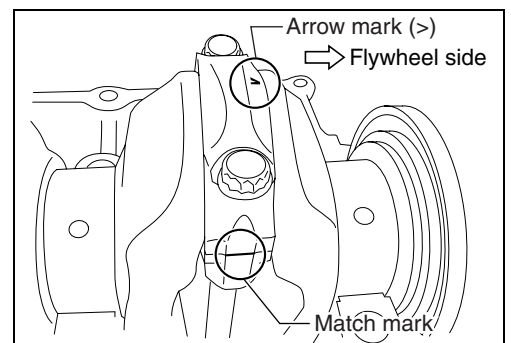
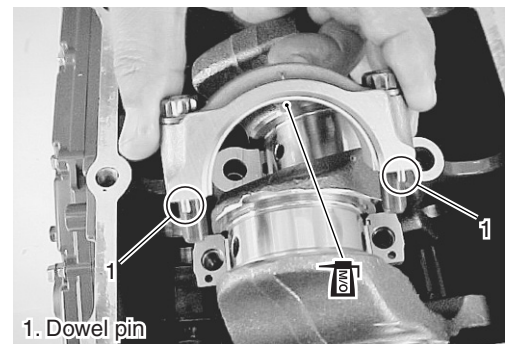
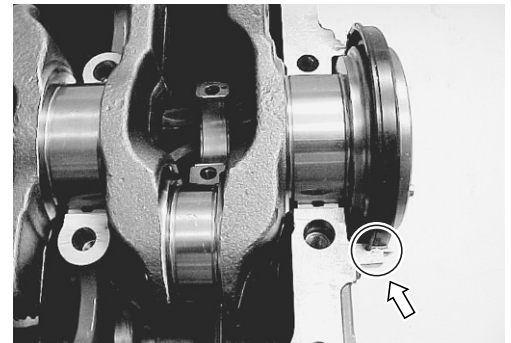
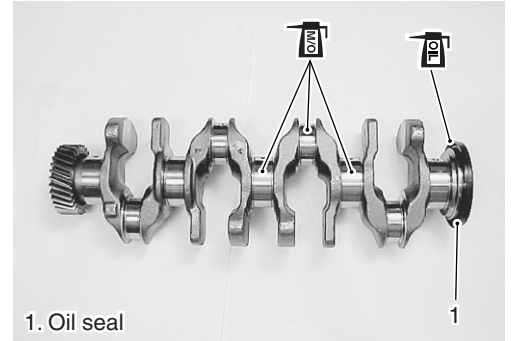



### CRANKCASE TO CYLINDER

Install the balancer gallery O-ring ①.

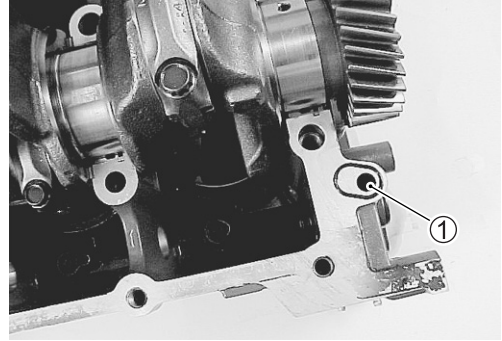

Clean mating surface of cylinder and crankcase.  
Apply SUZUKI BOND to mating surface of crankcase as shown.

#### CAUTION

**Apply bond to mating surface only.  
Do not allow bond to contact surface of bearing.**

 99000-31140: SUZUKI BOND "1207B"

Apply Bond  marked line.

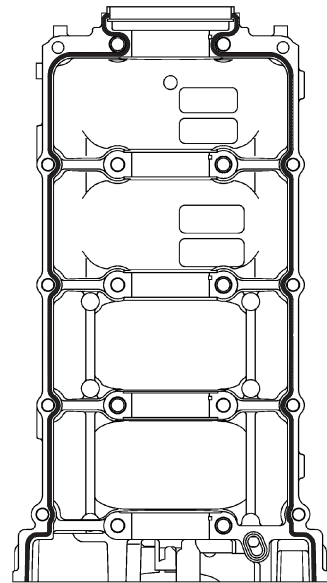

Install five (5) dowel pins ②.

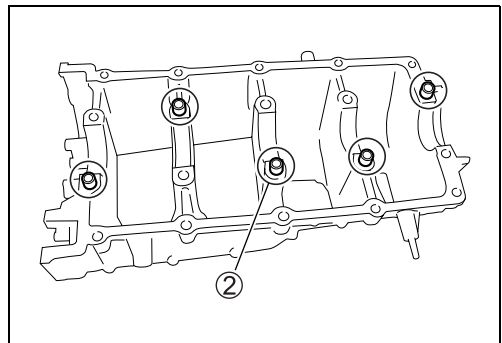

Install crankcase to cylinder.

Apply engine oil to crankcase bolts.

Tighten crankcase bolts in three (3) steps following the order indicated below.

**NOTE:**

Tighten 11 mm (0.433 in) thread diameter bolts first (following the order shown in figure), then tighten 10 mm (0.394 in) thread diameter bolts.

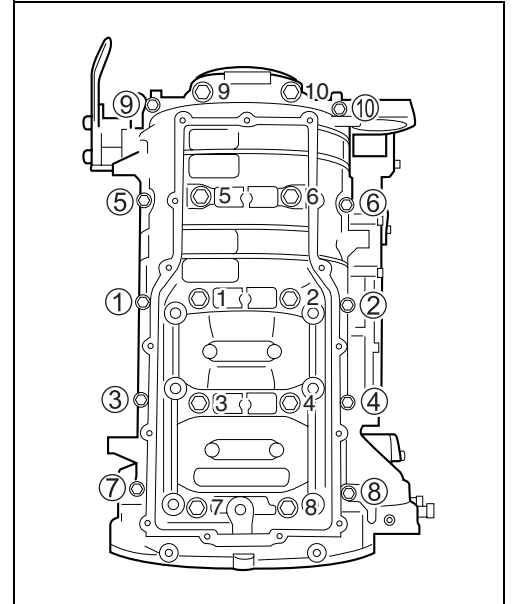

**☑ Crankcase inside bolt (11 mm thread diameter):**

1st step 11 N·m (1.1 kg-m, 8.0 lb-ft)

2nd step 46 N·m (4.6 kg-m, 33.3 lb-ft)

Final step 58 N·m (5.8 kg-m, 41.9 lb-ft)

**☑ Crankcase outside bolt (10 mm thread diameter):**

1st step 10 N·m (1.0 kg-m, 7.2 lb-ft)

2nd step 30 N·m (3.0 kg-m, 21.7 lb-ft)

Final step 37 N·m (3.7 kg-m, 26.8 lb-ft)

**NOTE:**

After tightening crankcase bolts, check to be sure that crankshaft rotates smoothly when turned by hand.

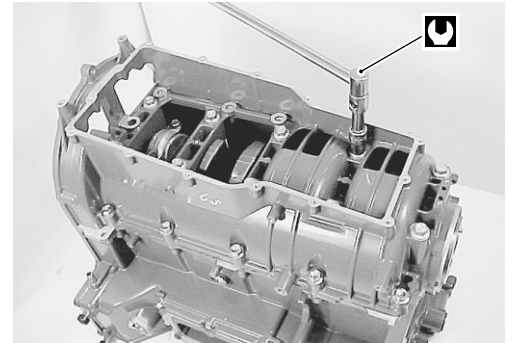

**OIL FILTER HOUSING**

- Install seal ring ① to oil filter housing ②.
- Install oil filter housing to cylinder block and secure with bolts ③.

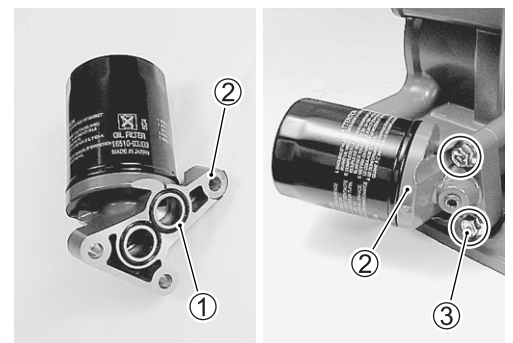

**COUNTER-BALANCER MECHANISM**

Install counter-balancer mechanism. (See page 6-81.)

**CYLINDER HEAD**

Install cylinder head. (See page 6-58 to 6-61.)

**TIMING CHAIN/BALANCER CHAIN**

Install timing chain and balancer chain. (See page 6-37 to 6-43 or 6-50 to 6-56.)

**OIL PUMP**

Install oil pump assembly. (See page 6-30.)

**POWER UNIT**

Install power unit. (See page 6-21 to 6-25.)

## THERMOSTAT REMOVAL

- Remove the ring gear cover and air intake silencer case. (See page 6-2.)
- Remove the flame arrester ①.
- Remove the three (3) bolts ② securing the thermostat cover ③, then remove the cover ③ and thermostat ④.

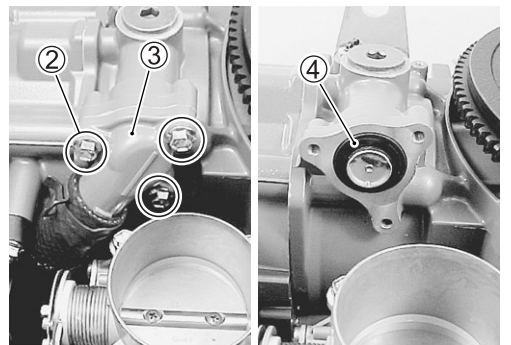
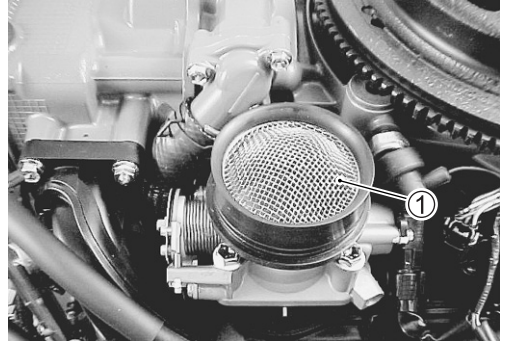

## INSPECTION

- If salt deposits, corrosion, wear or other damage is found, clean or replace.



### • Thermostat operation

Check thermostat opening temperature as follows:

- Insert a length of thread between thermostat valve/body and suspend thermostat in a container filled with water.
- Place thermometer in container and heat water. Observe water temperature when thermostat valve opens and releases thread.

#### **Thermostat operating temperature**

**Standard: 58 – 62 °C (136 – 144 °F)**

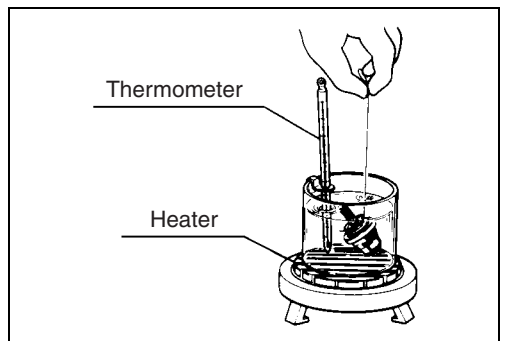

## INSTALLATION

Installation is reverse order of removal with special attention to the following steps.

- Assemble thermostat ① and thermostat cover ② to cylinder block and secure with bolts ③.

 **Thermostat cover bolt: 10 N·m (1.0 kg·m, 7.2 lb-ft)**

- Check to ensure that all removed parts are back in place.

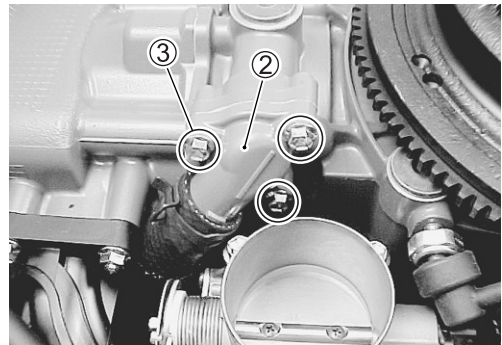
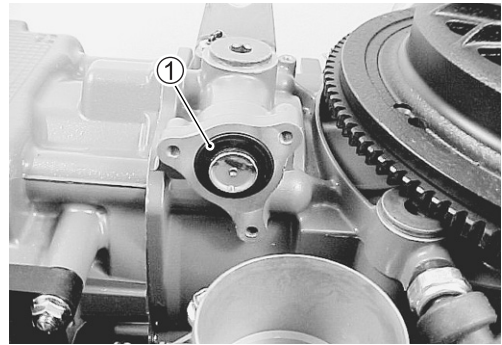



## OPERATION

### WATER COOLING SYSTEM

The water cooling system includes the lower unit water pump, lower unit to power unit water supply tube, oil pan water pressure valve, power unit water passages and thermostat.

This system cools both the power unit and exhaust and is shown in schematic form below.

If overheating occurs, the components of the cooling system must be inspected for blockage, corrosion build-up or component damage.

Component inspection	Refer to page
Water pump/Impeller.....	9-11, 10-11
Water tube.....	7-11
Thermostat.....	6-105
Water pressure valve.....	7-28
Cylinder head.....	6-63
Cylinder block.....	6-85

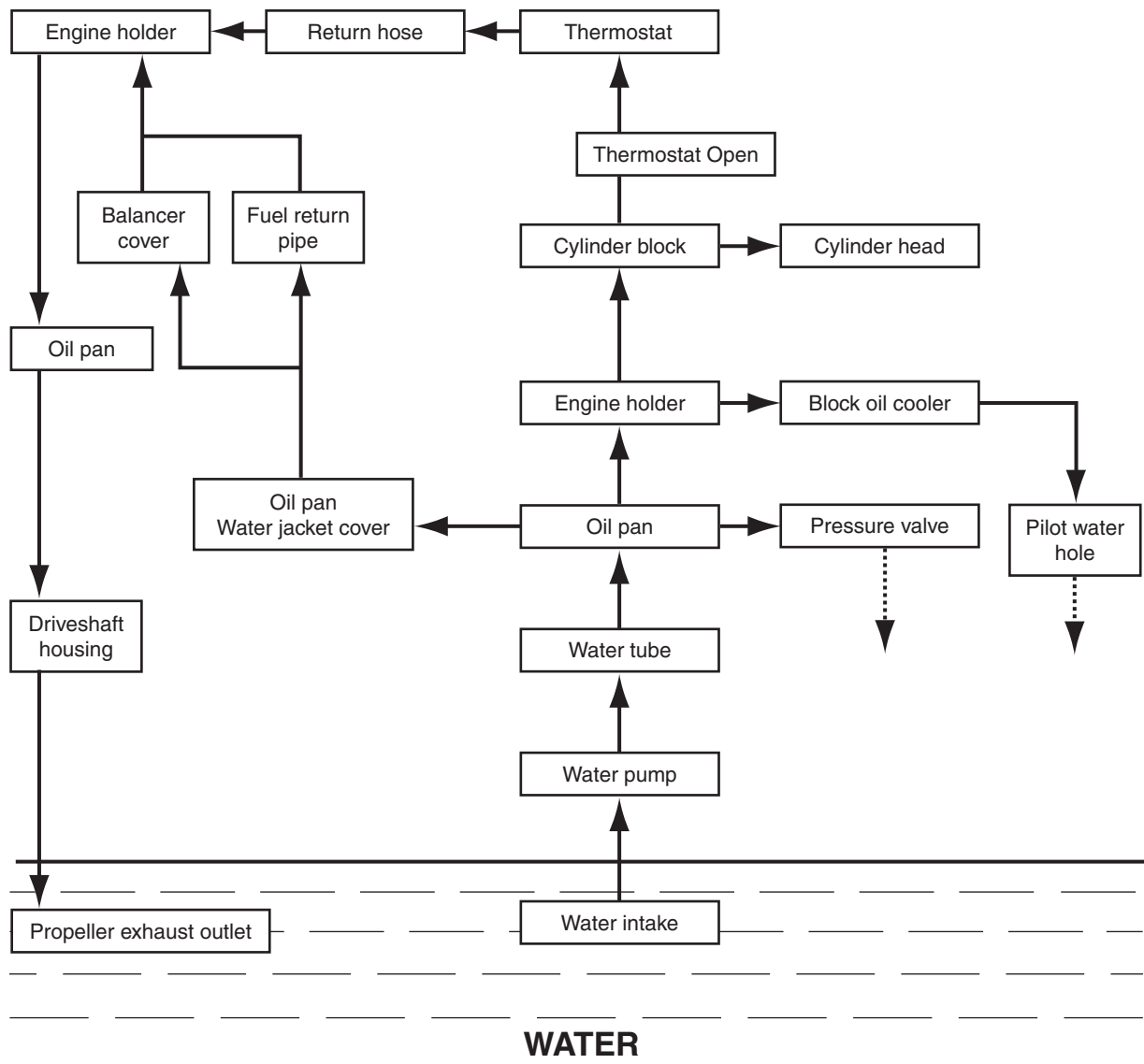

## ENGINE LUBRICATION SYSTEM

The engine lubrication system uses a camshaft-driven trochoid oil pump that pressure feeds engine oil to the engine' moving parts. The chart below shows the lubrication system oil flow.

Engine oil is drawn up by the oil pump through the oil strainer. After passing through the oil filter, engine oil flows to the main gallery from which various passages distribute oil for lubrication and other engine functions requiring engine oil pressure to operate.

Oil from the main gallery:

- Lubricates crankshaft journal bearings #1 through #5.
- Lubricates crank pins #1 through #4 and all pistons and cylinder walls.
- Lubricates counter- balancer shaft journals.
- Passes through cylinder head oil passage to lubricate IN. and EX. camshaft journals and cam faces.
- Supplies pressurized engine oil to operate the VVT system.

Oil flows to the VVT actuator through ECM controlled OCV to advance, retard or retain the intake valve timing.

ENGINE OIL LUBRICATION CHART

