

***PRE-PRODUCTION
ISSUE***

SUZUKI OUTBOARD MOTOR

DF150

DF175 ***FOUR STROKE***

SERVICE MANUAL

FOREWORD

This manual contains an introductory description of the SUZUKI DF150/175 Outboard motors and procedures for inspection, service and overhaul of their main components.

General knowledge information is not included.

Please read the GENERAL INFORMATION section to familiarize yourself with basic information concerning this motor. Read and refer to the other sections in this manual for information regarding proper inspection and service procedures.

This manual will help you better understand these outboard motors, assisting you in providing your customers with optimum and quick service.

- This manual has been prepared using the latest information available at the time of publication.
Differences may exist between the content of this manual and the actual outboard motor.
- Illustrations in this manual are used to show the basic principles of operation and work procedures and may not represent the actual outboard motor in exact detail.
- This manual is intended for use by technicians who already possess the basic knowledge and skills to service SUZUKI outboard motors.
Persons without such knowledge and skills should not attempt to service SUZUKI outboard engines by relying on this manual only and should contact an authorized SUZUKI outboard motor dealer.

⚠ WARNING

Apprentice mechanics or do-it-yourself mechanics that don't have the proper tools and equipment may not be able to properly perform the services described in this manual.

Improper repair may result in injury to the mechanic and may render the engine unsafe for the boat operator and passengers.

NOTE:

This manual is compiled based on 2006 (K6) model.

GROUP INDEX

GENERAL INFORMATION	1
PERIODIC MAINTENANCE	2
ENGINE CONTROL SYSTEM	3
ENGINE ELECTRICAL	4
FUEL SYSTEM	5
POWER UNIT	6
MID UNIT	7
POWER TRIM AND TILT	8
LOWER UNIT [Standard rotation (Right-hand) model]	9
LOWER UNIT [Counter rotation (Left-hand) model]	10
WIRE/HOSE ROUTING	11

HOW TO USE THIS MANUAL

TO LOCATE WHAT YOU ARE LOOKING FOR:

1. The text of this manual is divided into sections.
2. The section titles are listed on the previous page in a GROUP INDEX. Select the section needed for reference.
3. Holding the manual as shown at the right will allow you to find the first page of the section easily.
4. The first page of each section contains a table of contents to easily locate the item and page you need.

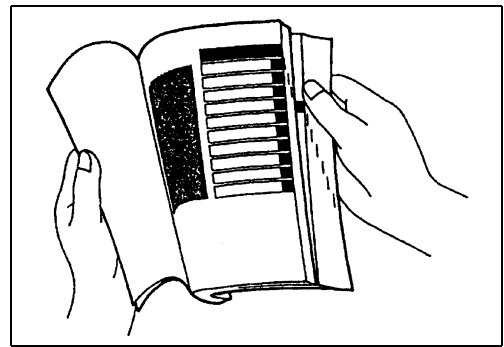

COMPONENT PARTS AND IMPORTANT ITEM ILLUSTRATIONS





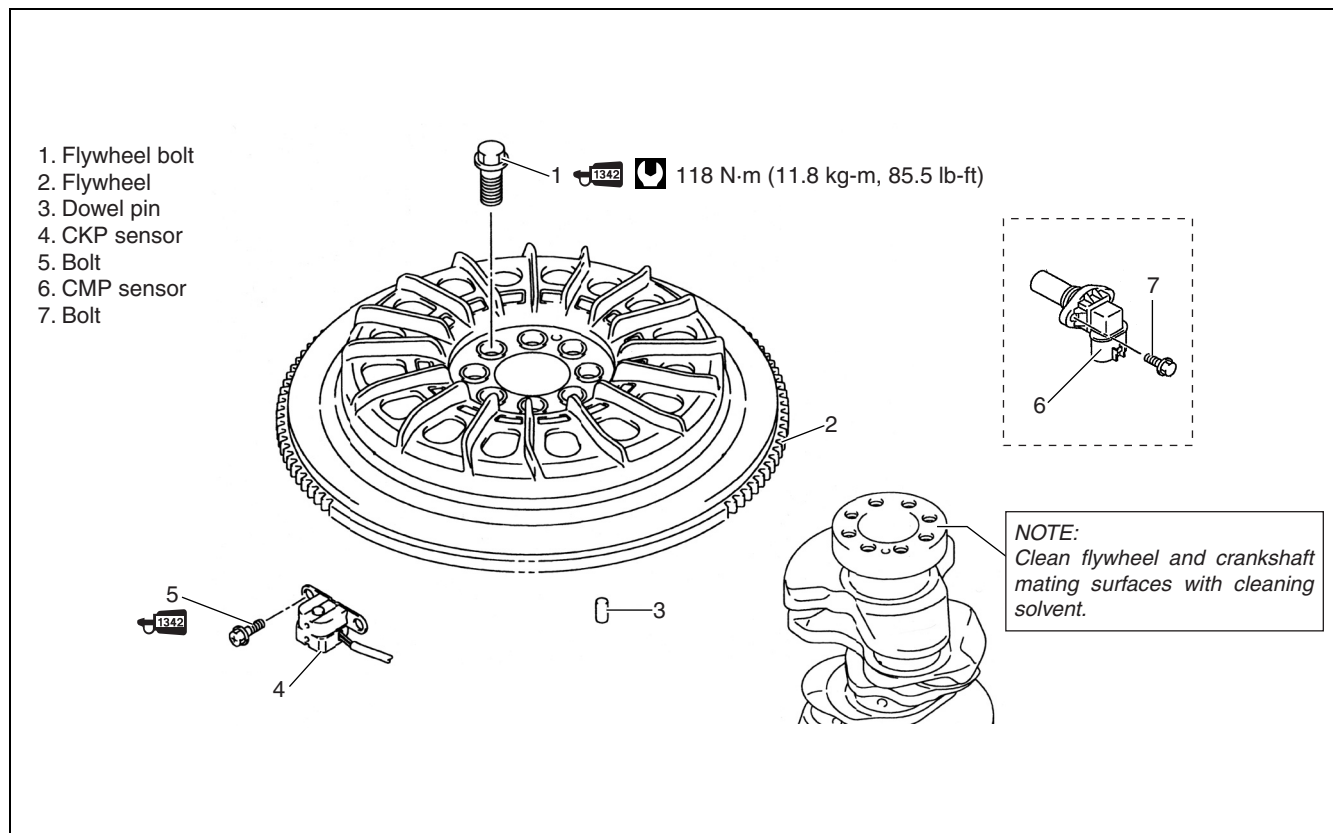











Under the name of each system or unit, an exploded view is provided with work instructions and other service information such as the tightening torque, lubrication and locking agent points.

Example:



SYMBOL

Listed in the table below are the symbols indicating instructions and other important information necessary for proper servicing. Please note the definition for each symbol. You will find these symbols used throughout this manual. Refer back to this table if you are not sure of any symbol(s) meanings.

SYMBOL	DEFINITION	SYMBOL	DEFINITION
	Torque control required. Data beside it indicates specified torque.		Apply SUZUKI SILICONE SEAL.
	Apply oil. Use the engine oil unless otherwise specified.		Apply THREAD LOCK "1342".
	Apply molybdenum oil solution. (Mixture of engine oil and SUZUKI MOLY PASTE in a ratio of 1 : 1)		Apply THREAD LOCK SUPER "1333B".
	Apply SUZUKI OUTBOARD MOTOR GEAR OIL.		Measure in DC voltage range.
	Apply SUZUKI SUPER GREASE "A".		Measure in resistance range.
	Apply SUZUKI MOLY PASTE. 99000-25140		Measure in continuity test range.
	Apply SUZUKI WATER RESISTANT GREASE.		Use peak voltmeter "Stevens CD-77".
	Apply SUZUKI BOND "1104".		Use special tool.
	Apply SUZUKI BOND "1207B".		

ABBREVIATIONS

Abbreviations used in this service manual are as follows:

BTDC	: Before Top Dead Center
CKP	: Crankshaft position
CMP	: Camshaft position
CTP	: Close Throttle position
DC	: Direct Current
DOHC	: Double Over Head Camshaft
ECM	: Engine Control Module
EX (Ex.)	: Exhaust
IAC	: Idle Air Control
IAT	: Intake Air Temperature
IN (In.)	: Intake
MAP	: Manifold absolute pressure
OCV	: Oil control valve
PORT	: Port
PTT	: Power Trim & Tilt
SPS	: Shift Position Sensor
STBD	: Starboard
TPS	: Throttle Position Sensor
VSV	: Vacuum switching valve
VVT	: Variable Valve Timing

GENERAL INFORMATION

1

CONTENTS

WARNING/CAUTION/NOTE	1- 2
GENERAL PRECAUTIONS	1- 2
IDENTIFICATION NUMBER LOCATION	1- 4
FUEL AND OIL	1- 5
GASOLINE RECOMMENDATION	1- 5
ENGINE OIL	1- 5
ENGINE BREAK-IN	1- 6
WARM-UP RECOMMENDATION	1- 6
THROTTLE RECOMMENDATION	1- 6
PROPELLERS	1- 7
POWERHEAD DIRECTION OF ROTATION	1- 8
CYLINDER NUMBER	1- 8
SPECIFICATIONS	1- 9
SERVICE DATA	1-12
TIGHTENING TORQUE	1-20
SPECIAL TOOLS	1-22
MATERIALS REQUIRED	1-26

WARNING/CAUTION/NOTE

Please read this manual and follow its instructions carefully. To emphasize special information, the symbol and the words WARNING, CAUTION and NOTE have special meanings. Pay special attention to the messages highlighted by these signal words.

⚠ WARNING

Indicates a potential hazard that could result in death or injury.

CAUTION

Indicates a potential hazard that could result in motor damage.

NOTE:

Indicates special information to make maintenance easier or instructions clearer.

Please note, however, that the warnings and cautions contained in this manual cannot possibly cover all potential hazards relating to the servicing, or lack of servicing, of the outboard motor. In addition to the WARNING and CAUTION stated, you must also use good judgment and observe basic mechanical safety principles.

GENERAL PRECAUTIONS

⚠ WARNING

- Proper service and repair procedures are important for the safety of the service mechanic and the safety and reliability of the outboard motor.
- To avoid eye injury, always wear protective goggles when filing metals, working on a grinder, or doing other work, which could cause flying material particles.
- When two or more persons work together, pay attention to the safety of each other.
- When it is necessary to run the outboard motor indoors, make sure that exhaust gas is vented outdoors.
- When testing an outboard motor in the water and on a boat, ensure that the necessary safety equipment is on board. Such equipment includes: flotation aids for each person, fire extinguisher, distress signals, anchor, paddles, bilge pump, first aid kit, emergency starter rope, etc.
- When working with toxic or flammable materials, make sure that the area you work in is well ventilated and that you follow all of the material manufacturer's instructions.
- Never use gasoline as a cleaning solvent.
- To avoid getting burned, do not touch the engine, engine oil or exhaust system during or shortly after engine operation.
- Oil can be hazardous. Children and pets may be harmed from contact with oil. Keep new and used oil away from children and pets. To minimize your exposure to oil, wear a long sleeve shirt and moisture-proof gloves (such as dishwashing gloves) when changing oil. If oil contacts your skin, wash thoroughly with soap and water. Launder any clothing or rags if wet with oil. Recycle or properly dispose of used oil.
- After servicing fuel, oil/engine cooling system and exhaust system, check all lines and fittings related to the system for leaks.
- Carefully adhere to the battery handling instructions laid out by the battery supplier.

CAUTION

- If parts replacement is necessary, replace the parts with Suzuki Genuine Parts or their equivalent.
- When removing parts that are to be reused, keep them arranged in an orderly manner so that they may be reinstalled in the proper order and orientation.
- Be sure to use special tools where instructed.
- Make sure that all parts used in assembly are clean and also lubricated when specified.
- When use of a certain type of lubricant, bond or sealant is specified, be sure to use the specified type.
- When removing the battery, disconnect the negative cable first and then the positive cable. When reconnecting the battery, connect the positive cable first and then the negative cable.
- When performing service to electrical parts, if the service procedures do not require using battery power, disconnect the negative cable at the battery.
- Tighten cylinder head and case bolts and nuts, beginning with larger diameter and ending with smaller diameter. Always tighten from inside to outside diagonally to the specified tightening torque.
- Whenever you remove oil seals, gaskets, packing, O-rings, locking washers, locking nuts, cotter pins, circlips, and certain other parts as specified, always replace them with new. Also, before installing these new parts, be sure to remove any left over material from the mating surfaces.
- Never reuse a circlip. When installing a new circlip, take care not to expand the end gap larger than required to slip the circlip over the shaft. After installing a circlip, always ensure that it is completely seated in its groove and securely fitted.
- Use a torque wrench to tighten fasteners to the torque values when specified.
- Remove grease or oil from screw/bolt threads unless a lubricant is specified.
- After assembly, check parts for tightness and operation.

- To protect the environment, do not unlawfully dispose of used motor oil, other fluids and batteries.
- To protect the Earth's natural resources, properly dispose of used motor parts.

IDENTIFICATION NUMBER LOCATION

MODEL, PRE-FIX, SERIAL NUMBER

The MODEL, PRE-FIX and SERIAL NUMBER of motor are stamped on a plate attached to the clamp bracket.

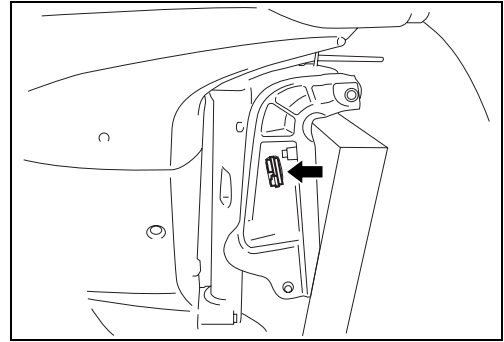

Example

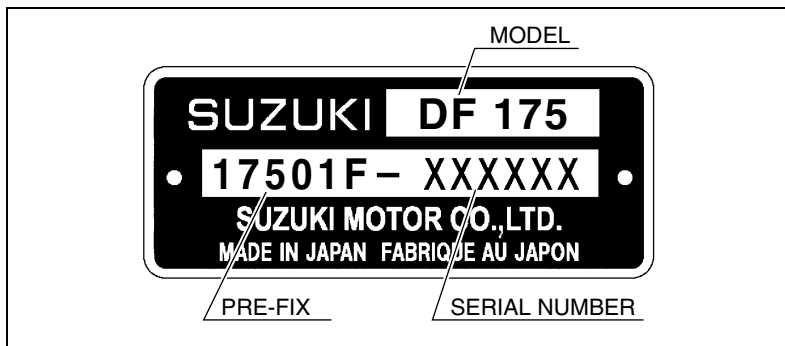

ENGINE SERIAL NUMBER

A second engine serial number plate is pressed into a boss on the cylinder block.

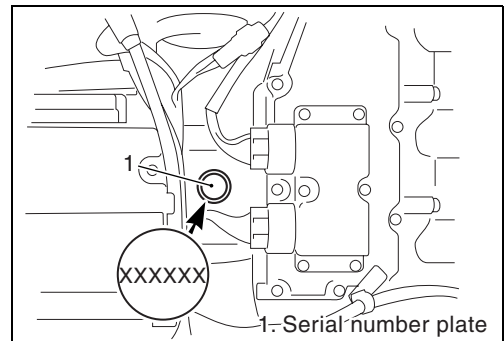

FUEL AND OIL

GASOLINE RECOMMENDATION

Suzuki highly recommends that you use alcohol-free unleaded gasoline with a minimum pump octane rating of 87 (R/2+M/2 method) or 91 (Research method). However, blends of unleaded gasoline and alcohol with equivalent octane content may be used.

Allowable maximum blend of a single additive (not combination):

5% Methanol, 10% Ethanol, 15% MTBE

CAUTION

**If leaded gasoline is used, engine damage may result.
Use only unleaded gasoline.**

ENGINE OIL

Use only oils that are rated SE, SF, SG, SH or SJ under the API (American Petroleum Institute) classification system or NMMA FC-W classification system.

The viscosity rating should be SAE (or NMMA FC-W) 10W-40.

If SAE (or NMMA FC-W) 10W-40 motor oil is not available, select an alternative according to the chart at right.

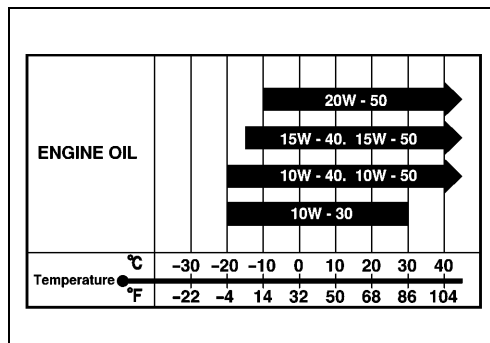

ENGINE BREAK-IN

The first 10 hours are critically important to ensure correct running of either a brand new motor or a motor that has been reconditioned or rebuilt. How the motor is operated during this time will have direct bearing on its life span and long-term durability.

Break-in period: 10 hours

WARM-UP RECOMMENDATION

Allow sufficient idling time (more than 5 minutes) for the engine to warm up after cold engine starting.

THROTTLE RECOMMENDATION

NOTE:

Avoid maintaining a constant engine speed for an extended period at any time during the engine break-in by varying the throttle position occasionally.

1. FIRST 2 HOURS

For the first 15 minutes, operate the engine in-gear at idling speed.

During the remaining 1 hour and 45 minutes, operate the engine in-gear at less than 1/2 (half) throttle (3 000 r/min).

NOTE:

The throttle may be briefly opened beyond the recommended setting to plane the boat, but must be reduced to the recommended setting immediately after planning.

2. NEXT 1 HOUR

Operate the engine in-gear at less than 3/4 (three-quarter) throttle (4 000 r/min).

3. LAST 7 HOURS

Operate the engine in-gear at desired engine speed.

However, do not operate continuously at full throttle for more than 5 minutes.

PROPELLERS

An outboard motor is designed to develop its rated power within a specified engine speed range. The maximum rated power delivered by the DF150/175 models are shown below.

Recommended full throttle speed range	DF150	5 000 – 6 000 r/min
	DF175	5 500 – 6 100 r/min

If the standard propeller fails to meet the above requirement, use another pitch propeller to hold the engine speed within the range specified above.

Propeller selection chart

Right-hand rotation models			Counter rotation models		
Blade	× Dia. (in.)	× Pitch (in.)	Blade	× Dia. (in.)	× Pitch (in.)
3	× 15 and 1/2	× 17	3	× 15 and 1/2	× 17
3	× 15 and 1/4	× 19	3	× 15 and 1/4	× 19
3	× 15	× 21	3	× 15	× 21
3	× 14 and 3/4	× 23	3	× 14 and 3/4	× 23
3	× 14 and 1/2	× 25	3	× 14 and 1/2	× 25
3	× 14 and 1/2	× 27	3	× 14 and 1/2	× 27
3	× 16	× 17	3	× 16	× 17
3	× 16	× 18 and 1/2	3	× 16	× 18 and 1/2
3	× 16	× 20	3	× 16	× 20
3	× 16	× 21 and 1/2	3	× 16	× 21 and 1/2
3	× 16	× 23	3	× 16	× 23
3	× 16	× 24 and 1/2	3	× 16	× 24 and 1/2
3	× 16	× 26	3	× 16	× 26
3	× 16	× 27 and 1/2			

CAUTION

Installing a propeller with pitch either too high or too low will cause incorrect maximum engine speed, which may result in severe damage to the motor.

NOTE:

In the case of twin installation, always use the same size right-hand rotation and counter-rotation propellers on both engines.

POWERHEAD DIRECTION OF ROTATION

This outboard motor is designed with a L.H. (left hand) rotation powerhead utilizing an offset crankshaft.

This design has the advantage of reducing the size of the motor and keeping the overall motor's weight closer to the boat transom and therefore closer to the boat C/G (center of gravity).

Rotation of the driveshaft is accomplished through a crankshaft drive gear and a driveshaft driven gear.

These gears are located beneath the powerhead in the same oil bath location as the camshaft chain.

As the rotational direction of the driven gear will be opposite of the drive gear, a left-hand rotation powerhead design was adopted to retain a conventional, standard rotation (right-hand) propeller shaft output.

CYLINDER NUMBER

Cylinder number is as mentioned in the right figure.

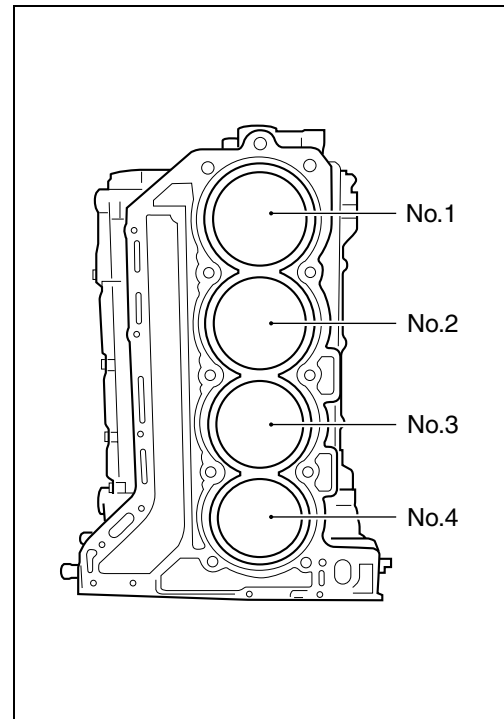

* SPECIFICATIONS

* These specifications are subject to change without notice.

Item	Unit	Data			
		DF150T	DF150Z	DF175T	DF175Z
PRE-FIX		15001F	15001Z	17501F	17501Z

DIMENSIONS & WEIGHT

Overall length (front to back)		mm (in.)	839 (33.0)
Overall width (side to side)		mm (in.)	519 (20.4)
Overall height	L	mm (in.)	1714 (67.5)
	X	mm (in.)	1841 (72.5)
Weight (without engine oil)	L	kg (lbs)	211 (465.2)
	X	kg (lbs)	215 (474.0)
Transom height	L	mm (in. type)	500 (20)
	X	mm (in. type)	627 (25)

PERFORMANCE

Maximum output	kW (PS)	110 (150)	129 (175)
Recommended operating range	r/min	5 000 – 6 000	5 500 – 6 100
Idle speed	r/min	650 ± 50 (in-gear: Approx. 650)	

POWER HEAD

Engine type	4-stroke DOHC		
Number of cylinders	4		
Bore	mm (in.)	97 (3.82)	
Stroke	mm (in.)	97 (3.82)	
Total displacement	cm ³ (cu. in)	2 867 (174.9)	
Compression ratio	: 1	9.5	
Spark plug	NGK	BKR6E	
Ignition system	Full-transistorized ignition		
Fuel supply system	Multi-point sequential electronic fuel injection		
Exhaust system	Through prop exhaust		
Cooling system	Water cooled		
Lubrication system	Wet sump by trochoid pump		
Starting system	Electric		
Throttle control	Remote control		

Item	Unit	Data			
		DF150T	DF150Z	DF175T	DF175Z

FUEL & OIL

Fuel		Suzuki highly recommends that you use alcohol-free unleaded gasoline with a minimum pump octane rating of 87 (R/2+M/2 method) or 91 (Research method). However, blends of unleaded gasoline and alcohol with equivalent octane content may be used.
Engine oil		<ul style="list-style-type: none"> • API classification : SE, SF, SG, SH, SJ or NMMA FC-W classification : SE, SF, SG, SH, SJ • Viscosity rating : SAE 10W-40 or NMMA FC-W 10W-40
Engine oil amounts	L (US/Imp. qt)	8.0 (8.5/7.0) : Oil change only 8.5 (9.0/7.5) : Oil filter change
Gear oil		SUZUKI Outboard Motor Gear Oil (SAE #90 hypoid gear oil)
Gearcase oil capacity	ml (US/Imp. oz)	1 100 (37.2/38.7)

BRACKET

Trim angle	degree	0 – 21 (PTT system)
Number of trim position		PTT system
Maximum tilt angle	degree	74

LOWER UNIT

Reversing system	Gear			
Transmission	Forward-Neutral-Reverse			
Reduction system	Bevel gear			
Gear ratio	12 : 25 (2.08)			
Drive line impact protection	Spline drive rubber hub			
Propeller shaft rotation (when shift into forward)	DF150T/175T : Clockwise DF150Z/175Z : Counterclockwise			
Propeller	Right-hand rotation models			
		Blade	× Dia. (in.)	× Pitch (in.)
		3	× 15 and 1/2	× 17
		3	× 15 and 1/4	× 19
		3	× 15	× 21
		3	× 14 and 3/4	× 23
		3	× 14 and 1/2	× 25
		3	× 14 and 1/2	× 27
		3	× 16	× 17
		3	× 16	× 18 and 1/2
		3	× 16	× 20
		3	× 16	× 21 and 1/2
		3	× 16	× 23
	3	× 16	× 24 and 1/2	
	3	× 16	× 26	
	3	× 16	× 27 and 1/2	

Item	Unit	Data			
		DF150T	DF150Z	DF175T	DF175Z

Propeller	Counter rotation models				
	Blade	×	Dia. (in.)	×	Pitch (in.)
	3	×	15 and 1/2	×	17
3	×	15 and 1/4	×	19	
3	×	15	×	21	
3	×	14 and 3/4	×	23	
3	×	14 and 1/2	×	25	
3	×	14 and 1/2	×	27	
3	×	16	×	17	
3	×	16	×	18 and 1/2	
3	×	16	×	20	
3	×	16	×	21 and 1/2	
3	×	16	×	23	
3	×	16	×	24 and 1/2	
3	×	16	×	26	

REDUCTION SYSTEM

1st reduction gear ratio (Crankshaft drive gear: Driven gear)	30 : 36 (1.20)
2nd reduction gear ratio (Lower unit gear)	12 : 25 (2.08)
Total reduction gear ratio	2.50 (36/30 × 25/12)

*** SERVICE DATA**

* These service data are subject to change without notice.

Item	Unit	Data	
		DF150T/Z	DF175T/Z

POWERHEAD

Recommended operating range	r/min	5 000 – 6 000	5 500 – 6 100
Idle speed	r/min	650 ± 50 (in-gear: Approx. 650)	
**Cylinder compression	kPa (kg/cm ² , psi)	1 100 – 1 700 (11 – 17, 156 – 242)	
**Cylinder compression max. difference between cylinders	kPa (kg/cm ² , psi)	100 (1.0, 14)	
**Engine oil pressure	kPa (kg/cm ² , psi)	400 – 600 (4.0 – 6.0, 57 – 85) at 3 000 r/min (at normal operating temp.)	
Engine oil		<ul style="list-style-type: none"> • API classification : SE, SF, SG, SH, SJ or NMMA FC-W classification : SE, SF, SG, SH, SJ • Viscosity rating : SAE 10W-40 or NMMA FC-W 10W-40 	
Engine oil amounts	L (US/lpm. qt)	8.0 (8.5/7.0) : Oil change only 8.5 (9.0/7.5) : Oil filter change	
Thermostat operating temperature	°C (°F)	58 – 62 (136 – 144)	

** Figures shown are guidelines only, not absolute service limits.

Item	Unit	Data	
		DF150T/Z	DF175T/Z

CYLINDER HEAD/CAMSHAFT

Cylinder head distortion	Limit	mm (in.)	0.03 (0.001)		
Manifold seating faces distortion	Limit	mm (in.)	0.10 (0.004)		
Cam height	IN	STD	mm (in.)	42.520 – 42.680 (1.6740 – 1.6803)	44.420 – 44.580 (1.7488 – 1.7551)
		Limit	mm (in.)	42.420 (1.6701)	44.320 (1.7449)
	EX	STD	mm (in.)	42.420 – 42.580 (1.6701 – 1.6764)	44.420 – 44.580 (1.7488 – 1.7551)
		Limit	mm (in.)	42.320 (1.6661)	44.320 (1.7449)
Camshaft journal oil clearance	Top, 2nd, 3rd, 4th, 5th	STD	mm (in.)	0.043 – 0.085 (0.0017 – 0.0033)	
		Limit	mm (in.)	0.120 (0.0047)	
Camshaft journal (housing) inside diameter	Top, 2nd, 3rd, 4th, 5th	STD	mm (in.)	26.000 – 26.021 (1.0236 – 1.0244)	
		Limit	mm (in.)	—	
Camshaft journal outside diameter	Top, 2nd, 3rd, 4th, 5th	STD	mm (in.)	25.936 – 25.957 (1.0211 – 1.0219)	
		Limit	mm (in.)	—	
Camshaft runout	Limit	mm (in.)	0.10 (0.004)		
Cylinder head bore to tappet clearance	STD	mm (in.)	0.025 – 0.066 (0.0010 – 0.0026)		
	Limit	mm (in.)	0.150 (0.0059)		
Tappet outer diameter	STD	mm (in.)	33.959 – 33.975 (1.3370 – 1.3376)		
Cylinder head bore	STD	mm (in.)	34.000 – 34.025 (1.3386 – 1.3396)		

Item	Unit	Data	
		DF150T/Z	DF175T/Z

VALVE/VALVE GUIDE

Valve diameter	IN		mm (in.)	35.9 (1.4)
	EX		mm (in.)	31.4 (1.2)
Tappet clearance (Cold engine condition)	IN	STD	mm (in.)	0.23 – 0.27 (0.009 – 0.011)
	EX	STD	mm (in.)	0.30 – 0.34 (0.012 – 0.013)
Valve seat angle	IN		—	15°, 45°, 60°
	EX		—	15°, 45°, 60°
Valve guide to valve stem clearance	IN	STD	mm (in.)	0.020 – 0.047 (0.0008 – 0.0019)
		Limit	mm (in.)	0.070 (0.0028)
	EX	STD	mm (in.)	0.045 – 0.072 (0.0018 – 0.0028)
		Limit	mm (in.)	0.090 (0.0035)
Valve guide inside diameter	IN, EX	STD	mm (in.)	5.500 – 5.512 (0.2165 – 0.2170)
Valve guide protrusion	IN, EX	STD	mm (in.)	11.4 – 11.8 (0.45 – 0.46)
Valve stem outside diameter	IN	STD	mm (in.)	5.465 – 5.480 (0.2152 – 0.2157)
	EX	STD	mm (in.)	5.440 – 5.455 (0.2142 – 0.2148)
Valve stem deflection	IN	Limit	mm (in.)	0.14 (0.006)
	EX	Limit	mm (in.)	0.18 (0.007)
Valve stem runout	IN, EX	Limit	mm (in.)	0.05 (0.002)
Valve head radial runout	IN, EX	Limit	mm (in.)	0.08 (0.003)
Valve head thickness	IN	STD	mm (in.)	1.1 (0.04)
		Limit	mm (in.)	0.7 (0.03)
	EX	STD	mm (in.)	1.05 (0.04)
		Limit	mm (in.)	0.7 (0.03)
Valve seat contact width	IN	STD	mm (in.)	1.1 – 1.3 (0.04 – 0.05)
	EX	STD	mm (in.)	1.1 – 1.3 (0.04 – 0.05)
Valve spring free length		STD	mm (in.)	40.2 (1.58)
		Limit	mm (in.)	38.6 (1.52)
Valve spring tension		STD	N (kg, lbs)	147 – 173 (15.0 – 17.7, 33.1 – 39.0) for 31.1 mm (1.22 in.)
		Limit	N (kg, lbs)	136 (13.9, 30.6) for 31.1 mm (1.22 in.)
Valve spring squareness		Limit	mm (in.)	2.0 (0.08)

Item	Unit	Data	
		DF150T/Z	DF175T/Z

CYLINDER/PISTON/PISTON RING

Cylinder distortion	Limit	mm (in.)	0.03 (0.001)	
Piston to cylinder clearance	STD	mm (in.)	0.085 – 0.105 (0.0033 – 0.0041)	
	Limit	mm (in.)	0.15 (0.0059)	
Cylinder bore	STD	mm (in.)	97.000 – 97.020 (3.8189 – 3.8197)	
Cylinder measuring position		mm (in.)	50 (1.969) from cylinder top surface	
Piston skirt diameter	STD	mm (in.)	96.905 – 96.925 (3.8152 – 3.8159)	
Piston measuring position		mm (in.)	9 (0.354) from piston skirt end	
Cylinder bore wear	Limit	mm (in.)	0.10 (0.039)	
Piston ring end gap	1st	STD	mm (in.)	0.20 – 0.30 (0.0079 – 0.0118)
		Limit	mm (in.)	0.70 (0.028)
	2nd	STD	mm (in.)	0.30 – 0.45 (0.0118 – 0.0177)
		Limit	mm (in.)	1.00 (0.039)
Piston ring free end gap	1st	STD	mm (in.)	Approx. 13.5 (0.5315)
		Limit	mm (in.)	10.8 (0.4252)
	2nd	STD	mm (in.)	Approx. 13.6 (0.5354)
		Limit	mm (in.)	10.9 (0.4291)
Piston ring to groove clearance	1st	STD	mm (in.)	0.030 – 0.070 (0.0012 – 0.0028)
		Limit	mm (in.)	0.12 (0.005)
	2nd	STD	mm (in.)	0.020 – 0.060 (0.0008 – 0.0024)
		Limit	mm (in.)	0.10 (0.004)
Piston ring groove width	1st	STD	mm (in.)	1.22 – 1.24 (0.048 – 0.049)
	2nd	STD	mm (in.)	1.21 – 1.23 (0.048 – 0.048)
	Oil	STD	mm (in.)	2.51 – 2.53 (0.099 – 0.100)
Piston ring thickness	1st	STD	mm (in.)	1.17 – 1.19 (0.046 – 0.047)
	2nd	STD	mm (in.)	1.17 – 1.19 (0.046 – 0.047)
Pin clearance in piston pin hole	STD	mm (in.)	—	
	Limit	mm (in.)	—	
Piston pin outside diameter	STD	mm (in.)	21.995 – 22.000 (0.8659 – 0.8661)	
	Limit	mm (in.)	—	
Piston pin hole diameter	STD	mm (in.)	22.006 – 22.014 (0.8664 – 0.8667)	
	Limit	mm (in.)	—	
Pin clearance in conrod small end	STD	mm (in.)	—	
	Limit	mm (in.)	—	
Conrod small end bore	STD	mm (in.)	21.968 – 21.979 (0.8649 – 0.8653)	

Item	Unit	Data	
		DF150T/Z	DF175T/Z

CRANKSHAFT/CONROD

Conrod small end inside diameter	STD	mm (in.)	21.968 – 21.979 (0.8649 – 0.8653)
Conrod big end oil clearance	STD	mm (in.)	0.045 – 0.063 (0.0018 – 0.0025)
	Limit	mm (in.)	0.080 (0.0031)
Conrod big end inside diameter	STD	mm (in.)	57.000 – 57.018 (2.2441 – 2.2448)
Crank pin outside diameter	STD	mm (in.)	53.982 – 54.000 (2.1253 – 2.1260)
Crank pin outside diameter difference (out-of-round and taper)	Limit	mm (in.)	0.010 (0.0004)
Conrod bearing thickness	STD	mm (in.)	1.482 – 1.497 (0.0583 – 0.0589)
Conrod big end side clearance	STD	mm (in.)	0.300 – 0.450 (0.0118 – 0.0177)
	Limit	mm (in.)	0.550 (0.0217)
Conrod big end width	STD	mm (in.)	22.750 – 22.800 (0.8957 – 0.8976)
Crank pin width	STD	mm (in.)	23.100 – 23.200 (0.9094 – 0.9134)
Crankshaft center journal runout	Limit	mm (in.)	0.04 (0.002)
Crankshaft journal oil clearance	STD	mm (in.)	0.030 – 0.050 (0.0012 – 0.0020)
	Limit	mm (in.)	0.065 (0.0026)
Crankcase bearing holder inside diameter	STD	mm (in.)	70.000 – 70.018 (2.7559 – 2.7566)
Crankshaft journal outside diameter	STD	mm (in.)	64.982 – 65.000 (2.5583 – 2.5591)
Crankshaft journal outside diameter difference (out-of-round and taper)	Limit	mm (in.)	0.010 (0.0004)
Crankshaft bearing thickness	STD	mm (in.)	2.497 – 2.512 (0.0983 – 0.0989)
Crankshaft thrust play	STD	mm (in.)	0.11 – 0.31 (0.004 – 0.012)
	Limit	mm (in.)	0.35 (0.014)
Crankshaft thrust bearing thickness	STD	mm (in.)	2.425 – 2.475 (0.0955 – 0.0974)

Item	Unit	Data	
		DF150T/Z	DF175T/Z

ELECTRICAL

Ignition timing	Degrees at r/min	BTDC 5 – 26 ± 3	
Over revolution limiter	r/min	6 200	6 300
CKP sensor resistance	Ω at 20 °C	168 – 252	
CMP sensor resistance	Ω at 20 °C	—	
Ignition coil resistance	Primary	Ω at 20 °C	
	Secondary	kΩ at 20 °C	
Battery charge coil resistance	Ω at 20 °C	0.14 – 0.20	
Battery charge coil output (12V)	Watt	528	
Standard spark plug	Type	NGK	
	Gap	mm (in.)	
Fuse amp. rating	A	Main fuse : 60 Starter motor : 30 Ignition coil, Injector, ECM : 30 PTT switch : 10 IAC, CMP, VSV, VVT : 10 Isolator : 30	
Recommended battery capacity (12V)	Ah (kC)	100 (360) or larger	
Fuel injector resistance	Ω at 20 °C	10 – 14	
IAC valve resistance	Ω at 20 °C	25 – 34	
IAT sensor/Cylinder temp. sensor/ Ex. mani. temp. sensor (Thermistor characteristic)	kΩ at 25 °C	1.8 – 2.3	
ECM main relay coil resistance	Ω at 20 °C	145 – 190	
Starter motor relay coil resistance	Ω at 20 °C	145 – 190	
PTT motor relay coil resistance	Ω at 20 °C	25 – 37	

STARTER MOTOR









Max. continuous time of use		Sec.	30
Motor output		kW	1.4
Brush length	STD	mm (in.)	16.0 (0.63)
	Limit	mm (in.)	12.0 (0.47)
Commutator undercut	STD	mm (in.)	0.5 – 0.8 (0.02 – 0.03)
	Limit	mm (in.)	0.2 (0.01)
Commutator outside diameter	STD	mm (in.)	29.0 (1.14)
	Limit	mm (in.)	28.0 (1.10)
Commutator outside diameter difference	STD	mm (in.)	0.05 (0.002)
	Limit	mm (in.)	0.40 (0.016)









PTT MOTOR

Brush length	STD	mm (in.)	9.8 (0.39)
	Limit	mm (in.)	5.5 (0.22)
Commutator outside diameter	STD	mm (in.)	22.0 (0.87)
	Limit	mm (in.)	21.0 (0.83)

SELF-DIAGNOSTIC SYSTEM INDICATION

When the abnormality occurs in a signal from sensor, switch, etc., the “CHECK ENGINE” lamp on the monitor-tachometer flashes (lights intermittently) according to the each code pattern with buzzer sounding.

PRIORITY *	FAILED ITEM	CODE	LAMP FLASHING PATTERN	FAIL-SAFE SYSTEM ACTIVATING
1	MAP sensor 1	3 – 4	on off 	YES
2	IAC valve/By-pass air screw adjustment	3 – 1	on off 	NO
3	Cylinder temp. sensor	1 – 4	on off 	YES
4	IAT sensor	2 – 3	on off 	YES
5	CKP sensor	4 – 2	on off 	NO
6	CMP sensor	2 – 4	on off 	YES
7	Air intake system	2 – 2	on off 	YES
8	MAP sensor 2 (Pressure detect passage)	3 – 2	on off 	NO
9	Exhaust manifold temp. sensor	1 – 5	on off 	YES

PRIORITY *	FAILED ITEM	CODE	LAMP FLASHING PATTERN	FAIL-SAFE SYSTEM ACTIVATING
10	Fuel injector	4 – 3	on  off	NO
11	Throttle position sensor	2 – 1	on  off	YES
12	Shift position sensor	1 – 2	on  off	YES
13	CMP sensor (VVT)	2 – 6	on  off	YES
14	VVT advance	5 – 2	on  off	YES
15	Neutral switch	3 – 3	on  off	NO
16	Model discrimination	4 – 1	on  off	YES
17	Oil control valve	6 – 2	on  off	NO
18	Rectifier & regulator (Over-charging)	1 – 1	on  off	NO

* If more than two items fail at once, the self-diagnostic indication appears according to priority order. The indication repeats three times.

TIGHTENING TORQUE

Tightening torque – Important fasteners



ITEM		THREAD DIAMETER	TIGHTENING TORQUE		
			N·m	kg·m	lb·ft
Cylinder head cover bolt		6 mm	11	1.1	8.0
Cylinder head bolt		8 mm	23	2.3	16.6
		12 mm	86	8.6	62.0
Crankcase bolt	Outside	10 mm	37	3.7	26.8
	Inside	11 mm	58	5.8	41.9
Crankshaft drive gear bolt		10 mm	48	4.8	34.7
Conrod cap bolt		9 mm	63	6.3	45.6
Camshaft housing bolt		6 mm	12	1.2	8.7
Oil pump bolt		8 mm	23	2.3	16.6
IN. camshaft timing sprocket	VVT model	—	60	6.0	43.4
	Non VVT model	—	78	7.8	56.0
EX. camshaft timing sprocket		—	78	7.8	56.0
OCV		6 mm	12	1.2	8.7
Chain tensioner adjuster bolt		6 mm	11	1.1	8.0
Timing chain guide bolt		8 mm	23	2.3	16.6
Intake manifold bolt/nut		8 mm	23	2.3	16.5
Oil pressure switch		—	13	1.3	9.5
Fuel delivery pipe bolt		8 mm	23	2.3	16.5
Fuel delivery pipe plug/ union bolt	Upper	14 mm	35	3.5	25.5
	Lower	14 mm	35	3.5	25.5
Low pressure fuel pump bolt		6 mm	10	1.0	7.0
Thermostat cover bolt		6 mm	10	1.0	7.0
Flywheel bolt		12 mm	118	11.8	85.3
Starter motor mounting bolt		8 mm	23	2.3	16.6
Engine oil filter		—	14	1.4	10.0
Engine oil drain plug		12 mm	13	1.3	9.5
Power unit mounting bolt		8 mm	23	2.3	16.5
		10 mm	50	5.0	36.0
Driveshaft housing bolt		10 mm	50	5.0	36.0
Upper mount nut		14 mm	100	10.0	72.3
Upper mount cover bolt		10 mm	50	5.0	36.0
Lower mount bolt		14 mm	100	10.0	72.3
Clamp bracket shaft nut		7/8-14 UNF	43	4.3	31.0
Water pump case bolt		8 mm	17	1.7	12.3
Driveshaft oil seal housing		—	100	10.0	72.5

ITEM	THREAD DIAMETER	TIGHTENING TORQUE		
		N-m	kg-m	lb-ft
Gearcase bolt	10 mm	54	5.5	40.0
	12 mm	83	8.3	60.0
Propeller shaft bearing housing bolt	8 mm	23	2.3	16.6
Pinion gear nut	16 mm	145	14.5	105.0
Propeller nut	18 mm	55	5.5	40.0

Tightening torque – General bolt





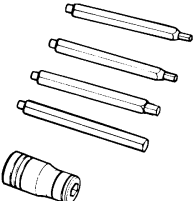
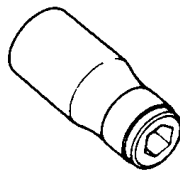
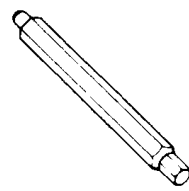
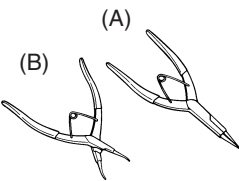
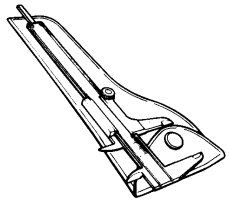
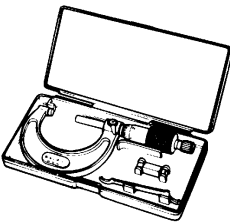
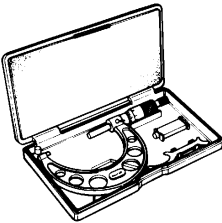
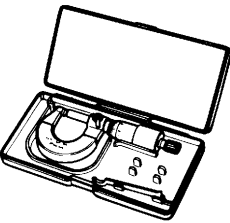
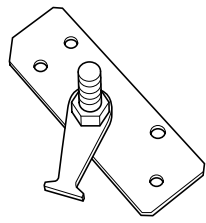
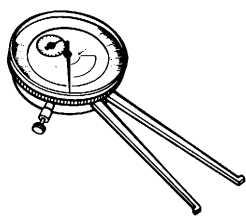
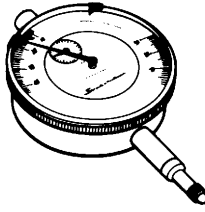
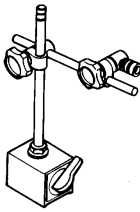
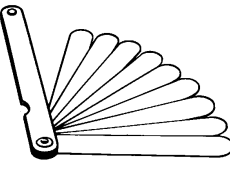
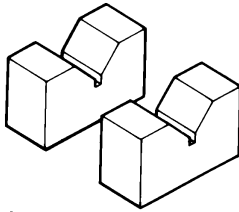
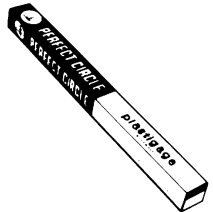

NOTE:

These value are only applicable when torque for a general bolt is not listed in the “Important Fasteners” table.

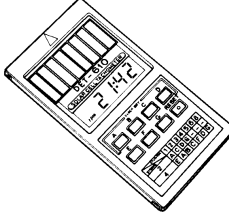
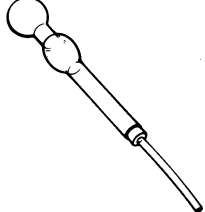
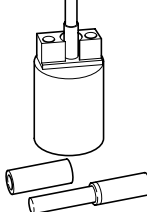
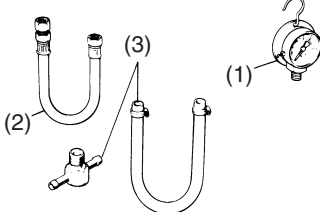
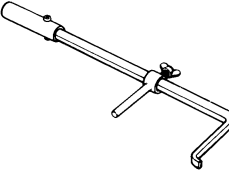
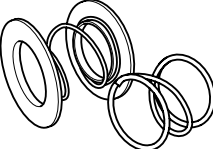
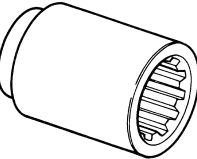
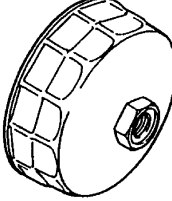
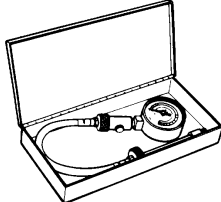
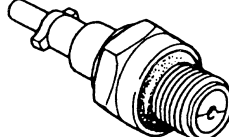

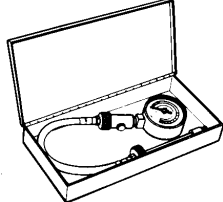
TYPE OF BOLT	THREAD DIAMETER	TIGHTENING TORQUE		
		N-m	kg-m	lb-ft
 (Conventional or “4” marked bolt)	5 mm	2 – 4	0.2 – 0.4	1.5 – 3.0
	6 mm	4 – 7	0.4 – 0.7	3.0 – 5.0
	8 mm	10 – 16	1.0 – 1.6	7.0 – 11.5
	10 mm	22 – 35	2.3 – 3.5	16.0 – 25.5
 (Stainless steel bolt)	5 mm	2 – 4	0.2 – 0.4	1.5 – 3.0
	6 mm	6 – 10	0.6 – 1.0	4.5 – 7.0
	8 mm	15 – 20	1.5 – 2.0	11.0 – 14.5
	10 mm	34 – 41	3.4 – 4.1	24.5 – 29.5
 (7 marked or 4 marked bolt)	5 mm	3 – 6	0.3 – 0.6	2.0 – 4.5
	6 mm	8 – 12	0.8 – 1.2	6.0 – 8.5
	8 mm	18 – 28	1.8 – 2.8	13.0 – 20.0
	10 mm	40 – 60	4.0 – 6.0	29.0 – 43.5

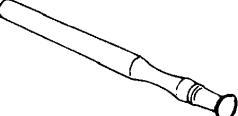
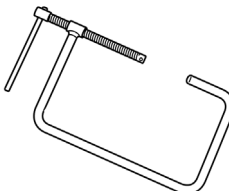
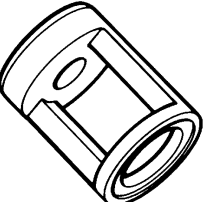
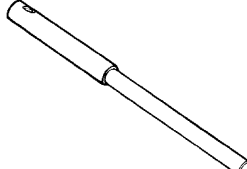
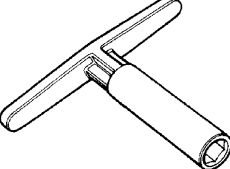

SPECIAL TOOLS

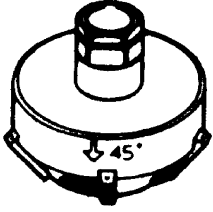
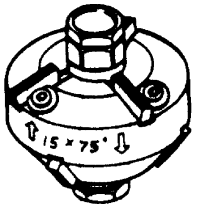
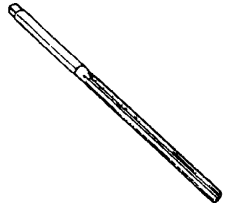
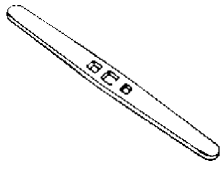
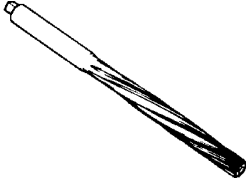
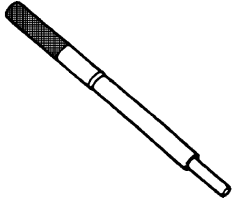
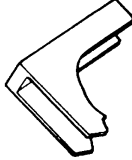
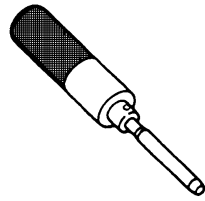
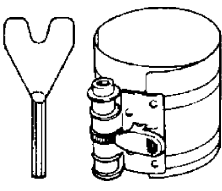
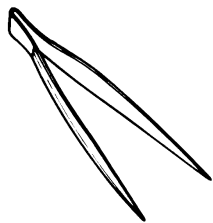
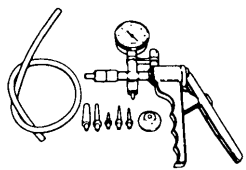
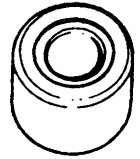
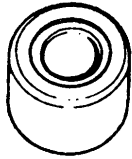
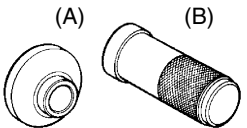
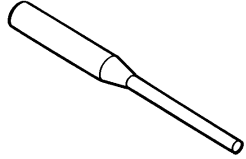
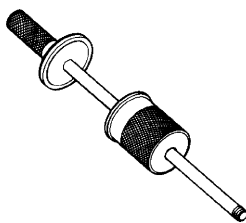
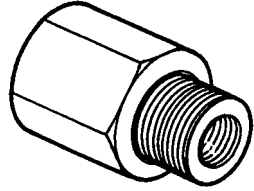
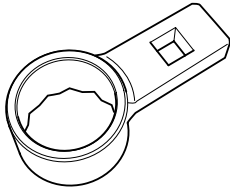
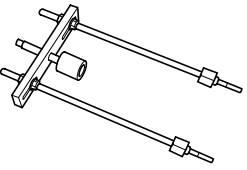
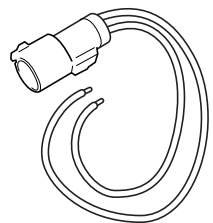
<p>1.</p>  <p>09900-00410 Hexagon wrench set</p>	<p>2.</p>  <p>09900-00411 Hexagon socket (included in 09900-00410)</p>	<p>3.</p>  <p>09900-00413 (5 mm) 09900-00414 (6 mm) 09900-00415 (8 mm) Hexagon bit (included in 09900-00410)</p>	<p>4.</p>  <p>(A) 09900-06107 (B) 09900-06108 Snap ring pliers</p>	<p>5.</p>  <p>09900-20101 (150 mm) 09900-20102 (200 mm) Vernier calipers</p>
<p>6.</p>  <p>09900-20202 Micrometer (25 – 50 mm)</p>	<p>7.</p>  <p>09900-20203 (50 – 75 mm) 09900-20204 (75 – 100 mm) Micrometer</p>	<p>8.</p>  <p>09900-20205 Micrometer (0 – 25 mm)</p>	<p>9.</p>  <p>09916-99311 Flywheel holder</p>	<p>10.</p>  <p>09900-20605 Dial calipers (10 – 34 mm)</p>
<p>11.</p>  <p>09900-20602 Dial gauge</p>	<p>12.</p>  <p>09900-20701 Magnetic stand</p>	<p>13.</p>  <p>09900-20803 Thickness gauge</p>	<p>14.</p>  <p>09900-21304 Steel “V” block set</p>	<p>15.</p>  <p>09900-22302 (0.051 – 0.125 mm) 09900-22301 (0.025 – 0.076 mm) Plastigauge</p>

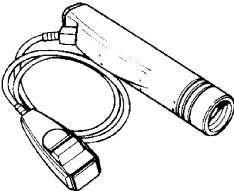
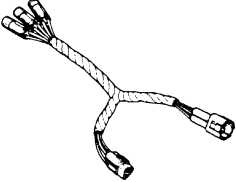
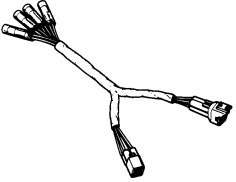
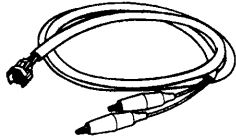
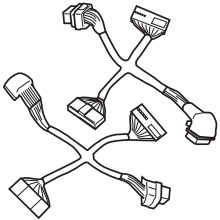
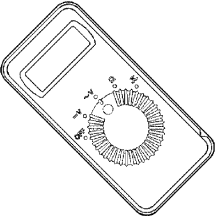
<p>16.</p>  <p>09900-26006 Engine tachometer</p>	<p>17.</p>  <p>09900-28403 Hydrometer</p>	<p>18.</p>  <p>09910-39610 Piston pin remover and installer</p>	<p>19.</p>  <p>09912-58413: Fuel pressure gauge set (1) 09912-58442: Fuel pressure gauge (2) 09912-58432: Fuel pressure hose (3) 09912-58490: 3-way joint & hose</p>	
<p>20.</p>  <p>09913-50121 Oil seal remover</p>	<p>21.</p>  <p>09951-09310 Gear adjust spring set</p>	<p>22.</p>  <p>09921-29410 Driveshaft holder</p>	<p>23.</p>  <p>09915-47341 Oil filter wrench</p>	<p>24.</p>  <p>09915-64512 Compression gauge</p>
<p>25.</p>  <p>09915-67010 Compression gauge hose attachment</p>	<p>26.</p>  <p>09915-64530 Compression gauge hose</p>	<p>27.</p>  <p>09915-77311 Oil pressure gauge</p>	<p>28.</p>  <p>09915-78211 Oil pressure gauge adapter</p>	<p>29.</p>  <p>09916-10911 Valve lapper</p>
<p>30.</p>  <p>09916-19030 Valve lifter</p>	<p>31.</p>  <p>09916-14521 Valve lifter attachment</p>	<p>32.</p>  <p>09916-24450 Solid pilot (N-100-5.52) Solid pilot Neway N-150-5.5</p>	<p>33.</p>  <p>09916-54910 Handle (N-505)</p>	<p>34.</p>  <p>09916-22420 Valve seat cutter (60°) (N-114)</p>

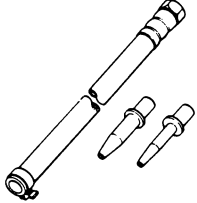
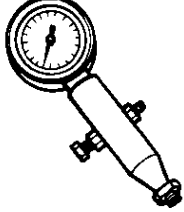
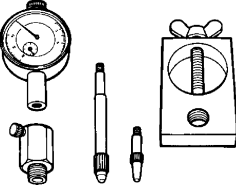
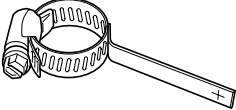
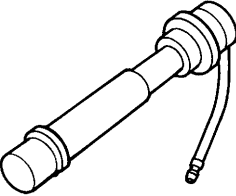
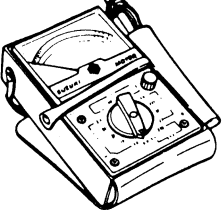
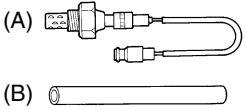
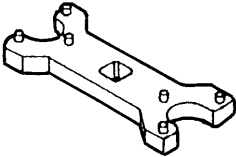
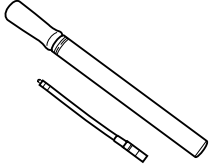
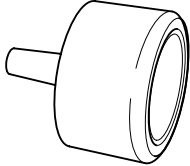
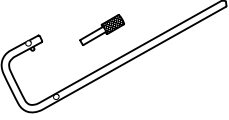
<p>35.</p>  <p>Valve seat cutter (45°) (Neway 128)</p>	<p>36.</p>  <p>Valve seat cutter (15°) (Neway 212)</p>	<p>37.</p>  <p>09916-34550 Valve guide reamer (φ 5.5 mm)</p>	<p>38.</p>  <p>09916-34542 Valve guide reamer handle</p>	<p>39.</p>  <p>09916-37320 Valve guide reamer (φ 10.5 mm)</p>
<p>40.</p>  <p>09916-44310 Valve guide remover</p>	<p>41.</p>  <p>09916-69310 Tappet holder</p>	<p>42.</p>  <p>09916-57330 Valve guide installer</p>	<p>43.</p>  <p>09916-77310 Piston ring com- pressor</p>	<p>44.</p>  <p>09916-84511 Tweezers</p>
<p>45.</p>  <p>09917-47011 Vacuum pump gauge</p>	<p>46.</p>  <p>09916-56011 Valve guide installer attachment</p>	<p>47.</p>  <p>09917-98221 Valve guide stem seal installer attach- ment</p>	<p>48.</p>  <p>(A) 09922-59410 Propeller shaft housing installer (B) 09922-59420 Housing installer handle</p>	<p>49.</p>  <p>09922-89810 Shift lock pin remover</p>
<p>50.</p>  <p>09930-30104 Sliding hammer</p>	<p>51.</p>  <p>09930-30161 Propeller shaft remover</p>	<p>52.</p>  <p>09926-29310 Driveshaft housing remover</p>	<p>53.</p>  <p>09951-99310 Gear holder</p>	<p>54.</p>  <p>09945-79310 PTT cable extension</p>

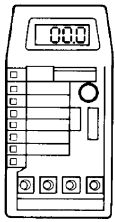
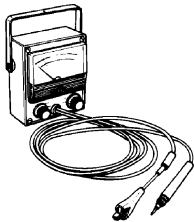





<p>55.</p>  <p>09930-76420 Timing light</p>	<p>56.</p>  <p>09930-89220 3-pin connector test cord</p>	<p>57.</p>  <p>09930-89240 4-pin connector test cord</p>	<p>58.</p>  <p>09930-89260 Injector test cord A</p>	<p>59.</p>  <p>09930-89340 26-pin & 34-pin test cord</p>
<p>60.</p>  <p>09930-99320 Digital tester</p>	<p>61.</p>  <p>09932-79910 Diagnostic harness 09932-89910 SDS adapter</p>	<p>62.</p>  <p>09940-44121 Air pressure gauge</p>	<p>63.</p>  <p>09940-44130 Attachment</p>	<p>64.</p>  <p>09950-69512 Gearcase oil leakage tester</p>
<p>65.</p>  <p>09951-09511 Gear adjusting gauge</p>	<p>66.</p>  <p>09952-09310 Back lash indicator tool</p>	<p>67.</p>  <p>09930-89350 H-T cord adapter</p>	<p>68.</p>  <p>09900-25002 Pocket tester</p>	<p>69.</p>  <p>(A) 18213-74F00 O2 sensor (B) 18498-99E70 Protector</p>
<p>70.</p>  <p>09944-09420 PTT cylinder cap tool</p>	<p>71.</p>  <p>09952-99310 Hand air pump</p>	<p>72.</p>  <p>09917-49610 Vacuum pump adapter</p>	<p>73.</p>  <p>09917-29610 Scissors gear alignment tool set</p>	

<p>74.</p>  <p>99954-53008-820* Digital voltmeter</p>	<p>75.</p>  <p>99954-53873* Stevens CD-77 Peak reading voltmeter</p>	<p>76.</p>  <p>99954-53883* Gear oil filler</p>
--	---	--

NOTE:

* Marked part No. is in U.S. market only.

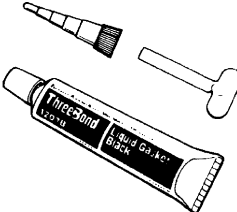
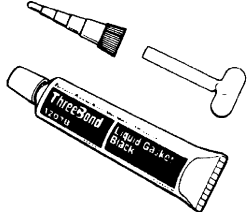
MATERIALS REQUIRED

<p>SUZUKI OUTBOARD MOTOR GEAR OIL</p>  <p>99000-22540 (400 ml x 24 pcs)</p>	<p>SUZUKI SUPER GREASE "A"</p>  <p>99000-25030* 99000-25010 (500 g)</p>	<p>WATER RESISTANT GREASE</p>  <p>99000-25160 (250 g)</p>	<p>SUZUKI SILICONE SEAL</p>  <p>99000-31120 (50 g)</p>	<p>SUZUKI BOND "1104"</p>  <p>99000-31030 (100 g)</p>
<p>SUZUKI BOND "1207B"</p>  <p>99104-33140* 99000-31140 (100 g)</p>	<p>THREAD LOCK "1342"</p>  <p>99000-32050 (50 g)</p>	<p>THREAD LOCK SUPER "1333B"</p>  <p>99000-32020 (50 g)</p>	<p>4-Stroke Motor Oil</p> <p>API: SE, SF, SG, SH, SJ SAE: 10W-40</p>	

NOTE:

* Marked part No. is in U.S. market only.

PERIODIC MAINTENANCE

CONTENTS

PERIODIC MAINTENANCE SCHEDULE	2- 2
 PERIODIC MAINTENANCE CHART	2- 2
MAINTENANCE AND TUNE-UP PROCEDURES	2- 3
 ENGINE OIL/ENGINE OIL FILTER	2- 3
 GEAR OIL	2- 6
 LUBRICATION	2- 7
 SPARK PLUG	2- 8
 TAPPET CLEARANCE	2- 9
 IDLE SPEED	2-16
 IGNITION TIMING	2-17
 BREATHER AND FUEL LINE	2-18
 LOW PRESSURE FUEL FILTER	2-19
 HIGH PRESSURE FUEL FILTER	2-19
 WATER PUMP/WATER PUMP IMPELLER	2-20
 PROPELLER/NUT/COTTER PIN	2-20
 BONDING WIRES	2-20
 ANODES	2-21
 BATTERY	2-22
 BALANCER CHAIN	2-23
 BOLTS AND NUTS	2-24
 FUEL MIXTURE CHECK (O2 FEEDBACK)	2-24
OIL PRESSURE	2-25
CYLINDER COMPRESSION	2-27
ENGINE VACUUM CHECK	2-28

PERIODIC MAINTENANCE SCHEDULE

The chart below lists the recommended intervals for all the required periodic service work necessary to keep the motor operating at peak performance and economy.

Maintenance intervals should be judged by number of hours or months, whichever comes first.

NOTE:

More frequent servicing should be performed on outboard motors that are used under severe conditions.

PERIODIC MAINTENANCE CHART

Item to be serviced	Interval	Initial 20 hrs. or 1 month	Every 50 hrs. or 3 months	Every 100 hrs. or 6 months	Every 200 hrs. or 12 months
Spark plug		—	—	I	R
Fuel line		I	I	I	I
	Replace fuel hose every 2 years.				
Breather hose		I	I	I	I
	Replace every 2 years.				
Engine oil [NOTE]		R	—	R	R
Gear oil		R	—	R	R
Lubrication		—	I	I	I
Anodes & Bonding wires		—	I	I	I
Battery		—	I	I	I
Fuel mixture check (O2 feedback)	Perform every 2 years.				
Engine oil filter		R	—	—	R
Low pressure fuel filter		—	I	I	I
	Replace every 400 hours or 2 years.				
High pressure fuel filter	Replace every 1 000 hours.				
Ignition timing		—	—	—	I
Idle speed		I	—	—	I
Tappet clearance		—	—	—	I
Water pump		—	—	—	I
Water pump impeller		—	—	—	R
Propeller nut & pin		I	—	I	I
Balancer chain	Replace every 1 600 hours.				
Bolt & Nuts		T	—	T	T

I: Inspect and clean, adjust, lubricate or replace, if necessary T: Tighten R: Replace

NOTE:

OIL CHANGE REMINDER SYSTEM

- Refer to page 3-44 for function and operation.
- See page 2-5 for reset information.

MAINTENANCE AND TUNE-UP PROCEDURES

This section describes servicing procedures for each periodic maintenance requirement.

ENGINE OIL/ENGINE OIL FILTER

ENGINE OIL LEVEL CHECK

Inspect oil level before every use.

1. Place outboard motor upright on a level surface.
2. Remove motor cover.
3. Remove oil level dipstick and wipe it clean.
4. Reinsert dipstick fully into dipstick tube, then remove to check oil level.

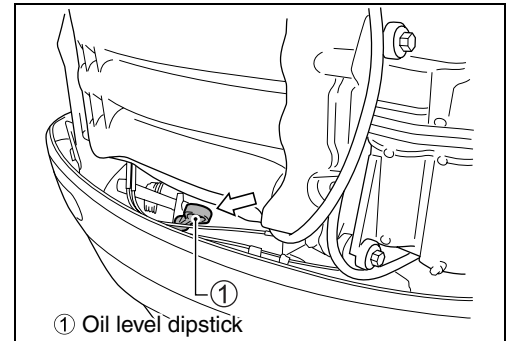

5. Oil level should be between full level Max. mark (hole) and low level Min. mark (hole).

If level is low, add recommended oil to full level Max. mark.

Recommended oil:

- 4 stroke motor oil
- API classification: SE, SF, SG, SH, SJ
or NMMA FC-W Classification: SE, SF, SG, SH, SJ
- Viscosity rating: SAE 10W-40 or NMMA FC-W 10W-40

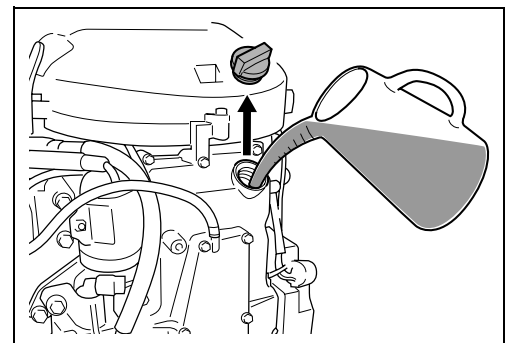
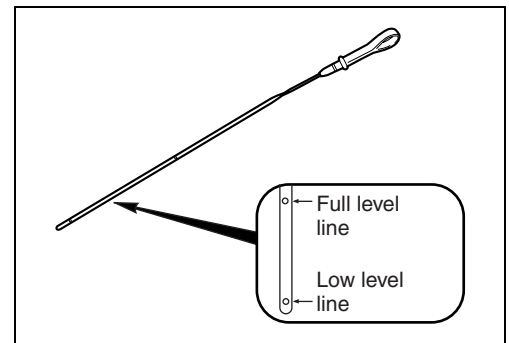

ENGINE OIL CHANGE/ENGINE OIL FILTER REPLACEMENT

ENGINE OIL

Change initially after 20 hours (1 month) and every 100 hours (6 months).

ENGINE OIL FILTER

Replace initially after 20 hours (1 month) and every 200 hours (12 months).

NOTE:

- Engine oil should be changed while engine is warm.
- When replacing engine oil filter, change engine oil at the same time.

1. Place outboard motor upright on a level surface.
2. Remove oil filler cap.
3. Place a container under engine oil drain plug.
4. Remove engine oil drain plug and gasket to drain engine oil.

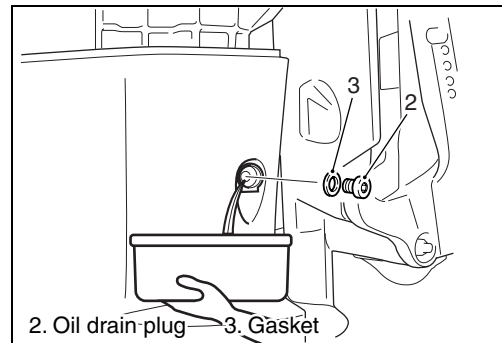
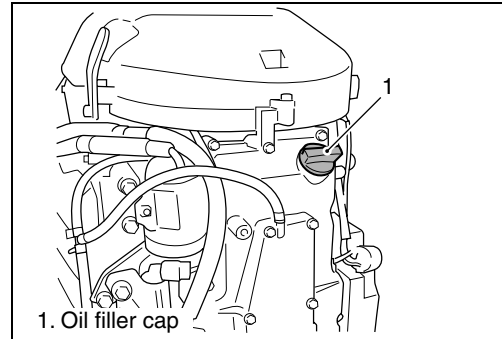

5. ENGINE OIL FILTER REPLACEMENT

NOTE:

For engine oil change only, go to step 6.

To replace engine oil filter:

- (1) Remove STBD side cover. (See page 7-2.)
- (2) Using oil filter wrench to loosen the oil filter, then remove filter and O-ring.

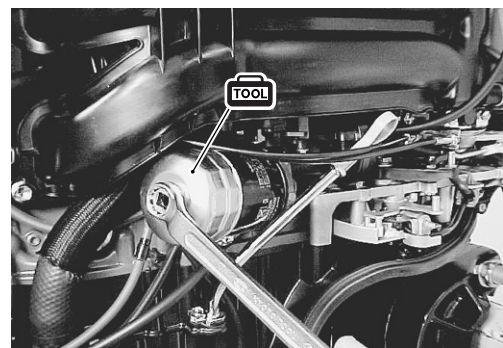

TOOL 09915-47341: Oil filter wrench

NOTE:

Before fitting new oil filter, be sure to oil O-ring.

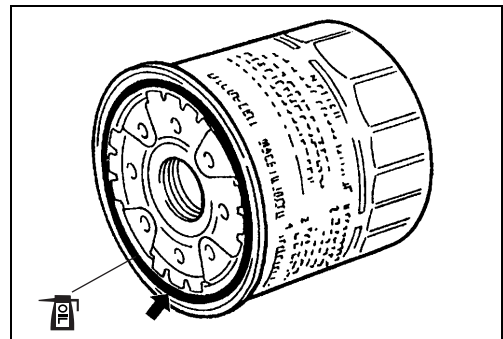

- (3) Screw new filter on by hand until filter O-ring contacts the mounting surface.
- (4) Tighten filter 3/4 turn from point of contact with mounting surface using an oil filter wrench.

 **Engine oil filter: 14 N·m (1.4 kg·m, 10.0 lb-ft), 3/4 turn**

- (5) Install STBD side cover.

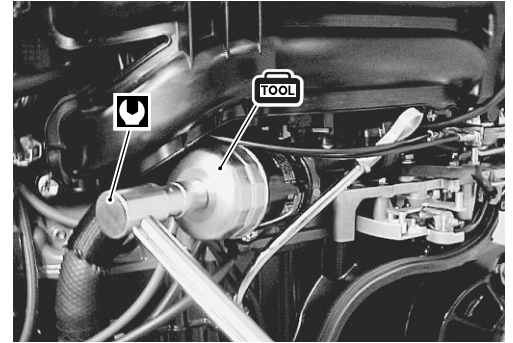

- 6. Install new gasket and oil drain plug.
- Tighten engine oil drain plug to specified torque.

 **Engine oil drain plug: 13 N·m (1.3 kg·m, 9.5 lb-ft)**

CAUTION

To avoid water entry into oil pan or oil leakage into the environment do not reuse gasket once removed. Always use a new gasket.

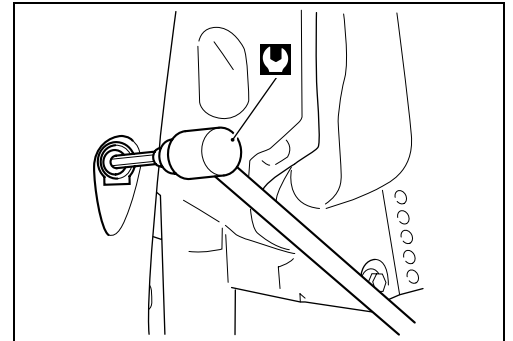

- 7. Pour recommended engine oil into oil filler opening, then install oil filler cap.

Engine oil amounts

Oil change only: 8.0 L (8.5/7.0 US/Imp. qt)

Oil filter change: 8.5 L (9.0/7.5 US/Imp. qt)

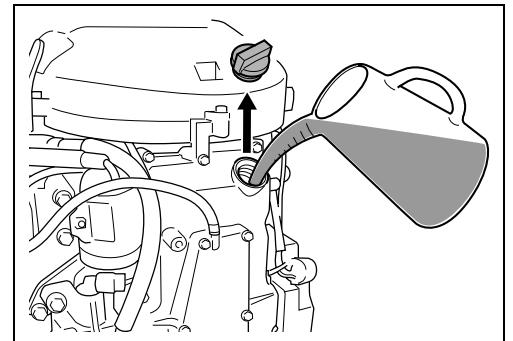

- 8. To reset oil change reminder system's operation time to zero (cancellation);

- (1) Turn ignition key to "ON" position.
- (2) Pull out emergency stop switch plate ①.
- (3) Pull up emergency stop switch knob ② three times in ten seconds. A short beep will be heard if cancellation is successfully finished.
- (4) Turn ignition key to "OFF" position, then set emergency stop switch plate ① in original position.

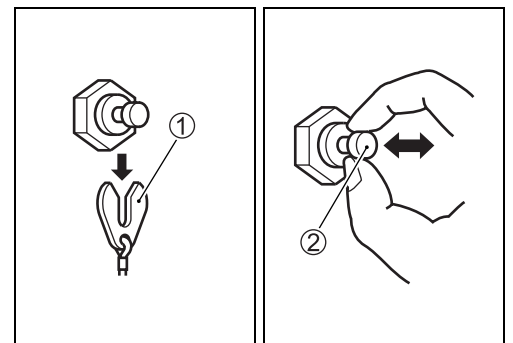

NOTE:

See "OIL CHANGE REMINDER SYSTEM" section on page 3-44.

- 9. Start engine and allow it to run for several minutes at idle speed.
- Check oil filter for oil leakage.
- Turn off engine and wait for approx. two minutes, then recheck engine oil level.

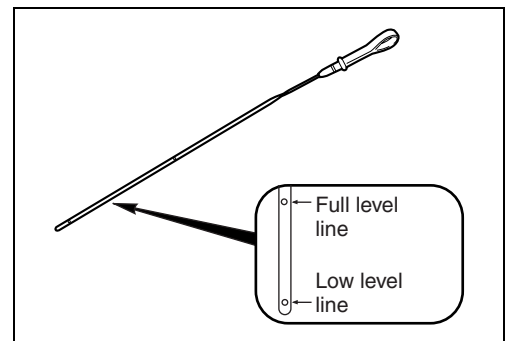

GEAR OIL

Change initially after 20 hours (1 month) and every 100 hours (6 months).

1. Place outboard motor upright on a level surface.
2. Place a container under the lower unit.
3. Remove lower gear oil drain plug first, then remove air vent plug and drain gear oil.

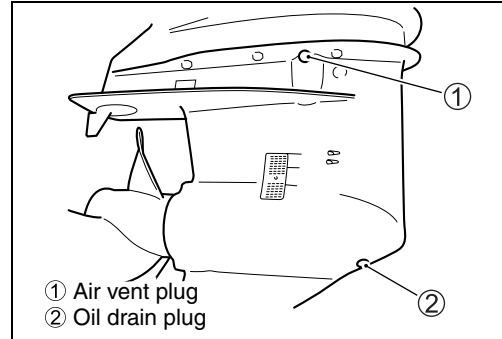

4. Fill with recommended gear oil through oil drain hole until oil just starts to flow out from air vent hole.

Gear oil amount: 1 100 ml (37.2/38.7 US/Imp. oz)

Recommended oils:

**SUZUKI OUTBOARD MOTOR GEAR OIL or
SAE #90 HYPOID GEAR OIL**

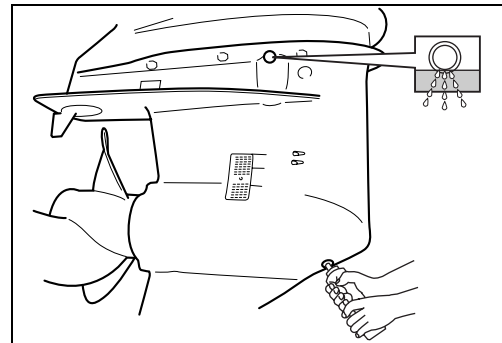

5. Install air vent plug before removing oil filler tube from drain hole.
6. Install oil drain plug.

CAUTION

Do not re-use gaskets once removed. Always use a new gasket.

NOTE:

To avoid a possible low gear oil level, recheck gear oil level 10 minutes after doing procedure in step 6. If oil level is low, add additional gear oil until level is correct.

7. To check the gear oil level:
 - (a) Remove the oil level plug.
 - (b) If oil can be seen at oil level plug level, the unit is full.
 - (c) If oil level is low, re-fill with gear oil through oil level hole.
 - (d) Install oil level plug.

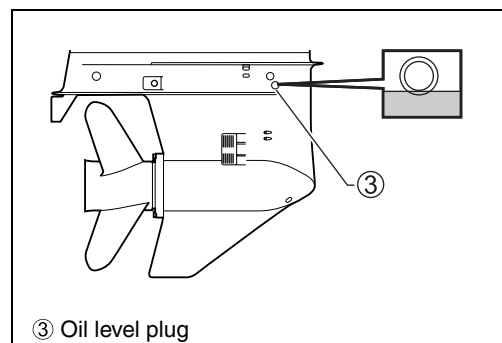

LUBRICATION

Inspect every 50 hours (3 months).

Apply SUZUKI Water Resistant Grease to the following points.

 **99000-25160: SUZUKI WATER RESISTANT GREASE**

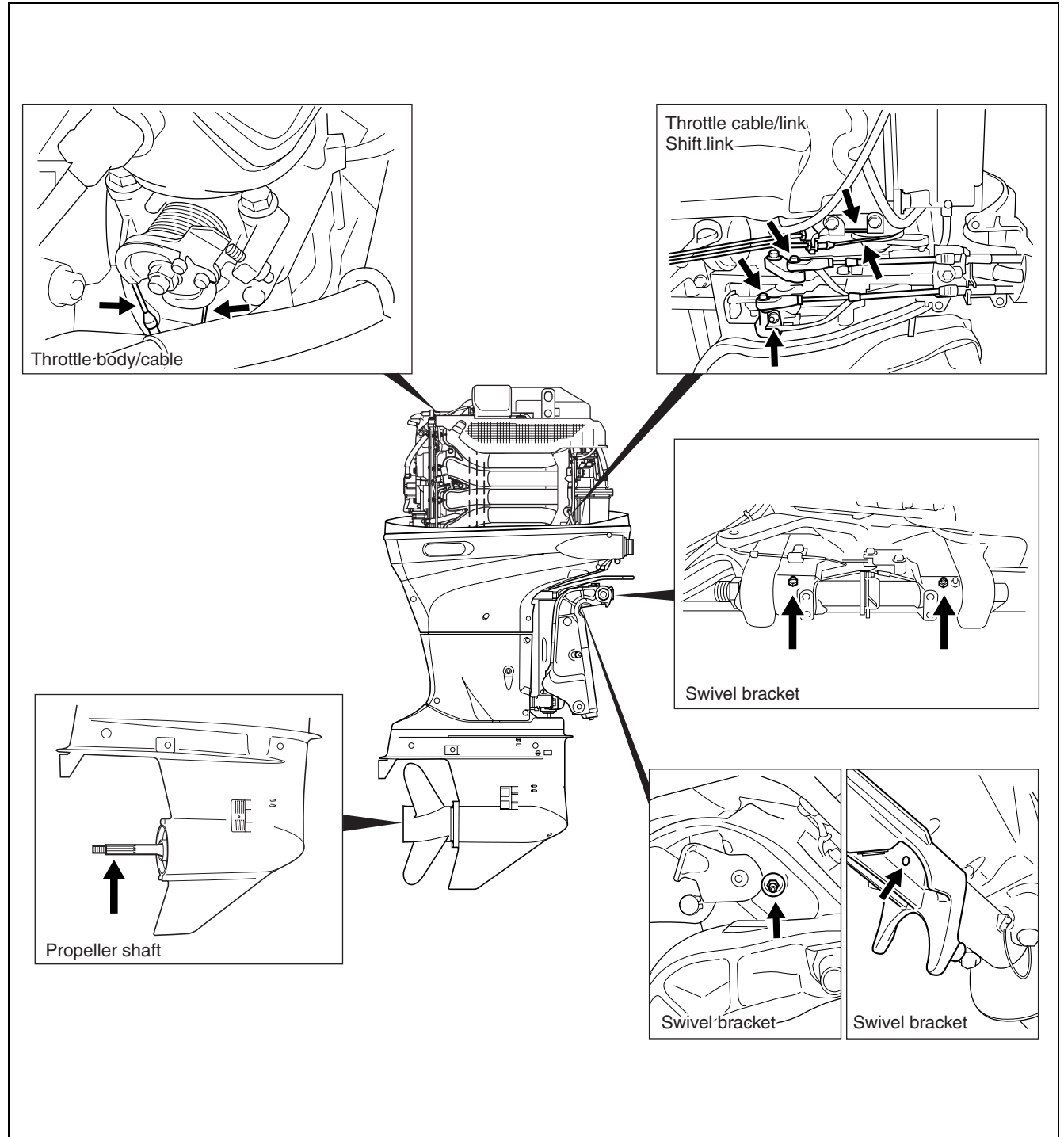

SPARK PLUG

- Inspect every 100 hours (6 months).
- Replace every 200 hours (12 months).

Standard spark plug: NGK BKR6E

CAUTION

Only resistor (R) type spark plugs must be used with this engine. Using a non-resistor spark plug will cause ignition and fuel injection system malfunctions.

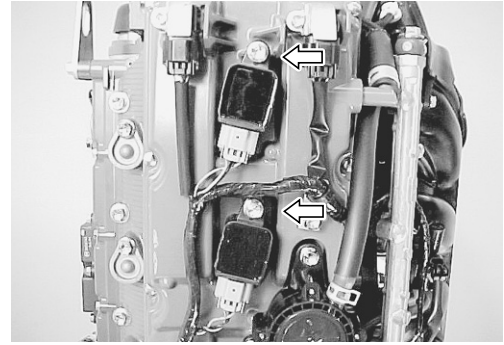

REMOVAL

- Disconnect ignition coil connector, then remove the bolt securing the ignition coil.
- Remove the ignition coil and spark plug.

CARBON DEPOSIT

Inspect for a carbon deposit on spark plug base. If carbon is present, remove it with a spark plug cleaning machine or by carefully using a pointed tool.

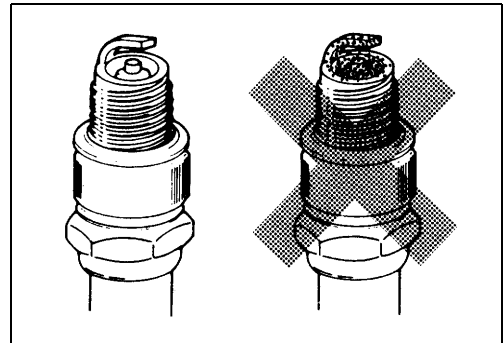

SPARK PLUG GAP

Measure spark plug gap with a thickness gauge. Adjust to within specified range if gap is out of specification.

Spark plug gap: 0.7 – 0.8 mm (0.028 – 0.031 in)

 09900-20803: Thickness gauge

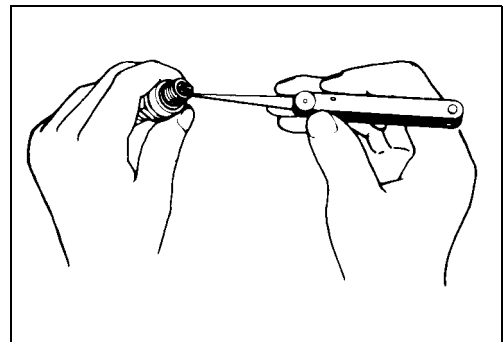

CONDITION OF ELECTRODE

Inspect electrode for a worn or burnt condition. If it is extremely worn or burnt, replace spark plug. Also, be sure to replace spark plug if it has a broken insulator, damaged thread, etc.

CAUTION

Confirm the thread size and reach when replacing the plug. If the reach is too short, carbon will be deposited on the threaded portion of the plug hole resulting in possible engine damage.

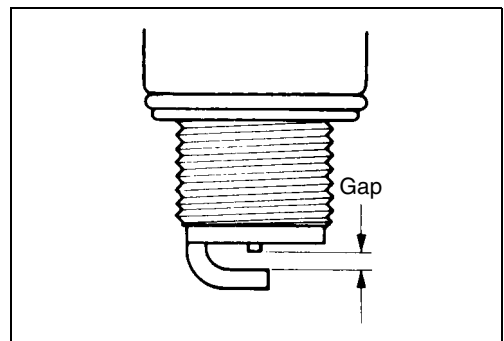

INSTALLATION

Installation is reverse order of removal.

 **Spark plug: 28 N·m (2.8 kg·m, 20.0 lb·ft)**

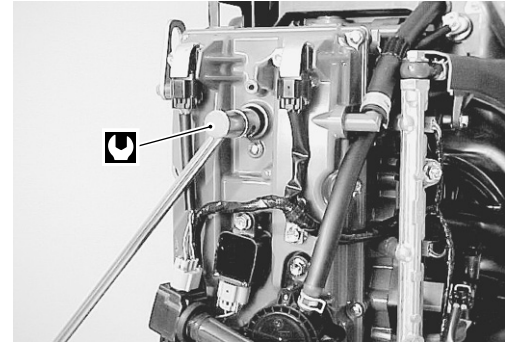

TAPPET CLEARANCE

Inspect every 200 hours (12 months).

The tappet clearance specification is different for intake and exhaust valves.

Too small a tappet clearance may reduce engine power, too large a tappet clearance increases valve noise and hastens valve and seat wear.

When the tappets are set to the specified clearance, the engine will run without excessive noise from the valve mechanism and will deliver full power. In this engine, the tappet clearance is increased or decreased by replacing the shim disc, made of a special wear resistant material, fitted to the top of the tappet.

Using the proper tools provides for easy removal and installation of the shim disc.

Tappet clearance adjustment should be checked and adjusted:

- during scheduled periodic inspection.
- when valve mechanism is serviced.
- when camshafts are disturbed by removing them for inspection.

CHECKING AND ADJUSTING TAPPET CLEARANCE

1. To remove the cover ①, pull the upper part outward, then lift up.

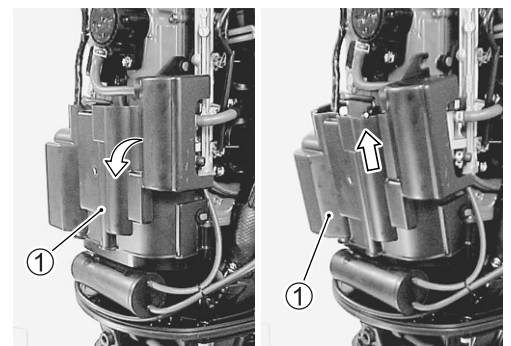

2. Remove following parts:

- Engine side lower cover (See page 7-2.)
- Ring gear cover and air intake silencer case (See page 6-2.)
- Ignition coils
- Spark plugs

3. Remove the cylinder head cover. (See page 6-11.)

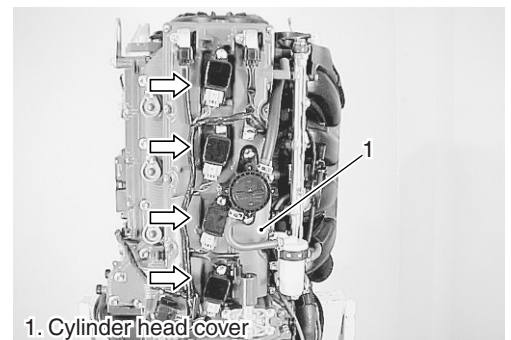

1. Cylinder head cover

4. Rotate crankshaft counterclockwise to bring cam nose vertical to shim surface.
5. Measure tappet clearances by inserting thickness gauge between cam and shim surface.

Tappet clearance (cold engine condition):

IN.: 0.23 – 0.27 mm (0.009 – 0.011 in)

EX.: 0.30 – 0.34 mm (0.012 – 0.013 in)

 **09900-20803: Thickness gauge**

CAUTION

**This is a left hand (LH) rotation powerhead.
Rotate crankshaft counterclockwise to prevent water pump impeller damage.**

NOTE:

- Rotate crankshaft and measure clearance for each tappet respectively by bringing cam nose vertical to shim surface.
- All tappet clearances can be measured during two crankshaft rotations.

6. If out of specification, adjust tappet clearance by changing shim.

ADJUSTMENT

Tappet clearances are adjusted by replacing tappet shim.

1. With cam nose vertical to valve, turn tappet cut-away towards center of cylinder head as shown in figure.

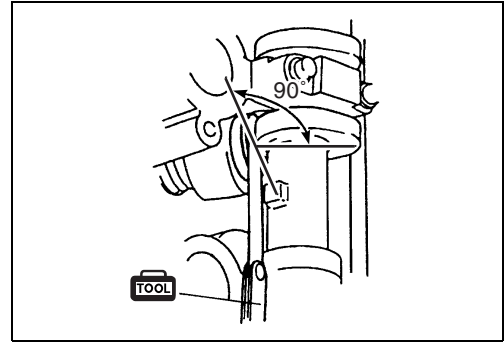

2. Rotate crankshaft to open (lift up) valve and then remove camshaft housing bolts where shim is to be replaced.
3. Install special tool with camshaft housing bolts as shown in figure.

 **09916-69310: Tappet holder**

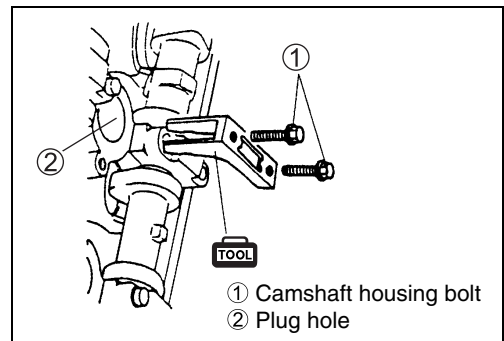
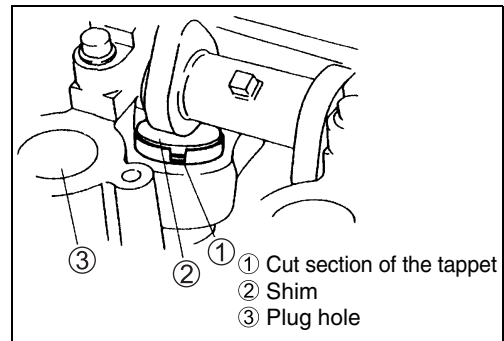

- Rotate top of cam 90 degree counterclockwise and remove shim from cut-away at tappet.
(Two tappets can be adjusted at the same time.)

CAUTION

- Do not put your finger between camshaft and tappet while the tappet is being held with the tappet holder.
- Use a magnet to remove and install shim.
- When installing shim, identification mark on the shim should face down (towards tappet).

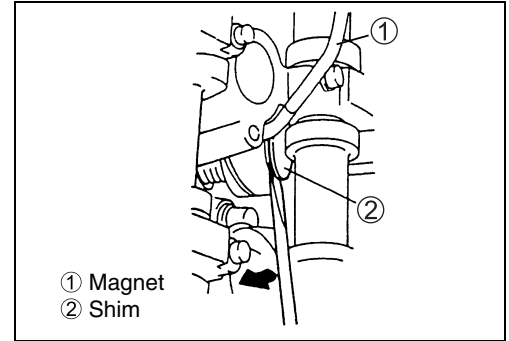

- After removing shim, measure thickness of original shim and determine correct thickness of shim for proper tappet clearance as calculated by following formula.

TOOL 09900-20205: Micrometer

IN. side:

$$A = B + (C - 0.25 \text{ mm})$$

EX. side:

$$A = B + (C - 0.32 \text{ mm})$$

A: Correct thickness of shim for proper tappet clearance (mm)

B: Thickness of original shim (mm)

C: Original tappet clearance (mm)

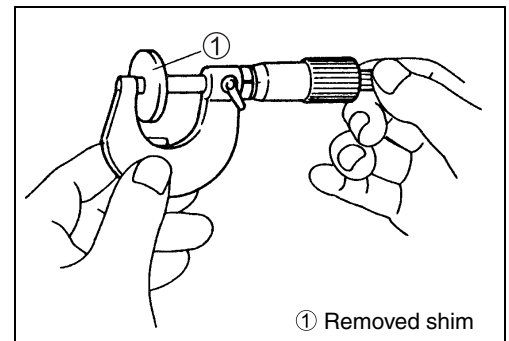

I.D No.	Thickness (mm)	I.D No.	Thickness (mm)	I.D No.	Thickness (mm)
218	2.18	248	2.48	278	2.78
220	2.20	250	2.50	280	2.80
223	2.23	253	2.53	283	2.83
225	2.25	255	2.55	285	2.85
228	2.28	258	2.58	288	2.88
230	2.30	260	2.60	290	2.90
233	2.33	263	2.63	293	2.93
235	2.35	265	2.65	295	2.95
238	2.38	268	2.68	298	2.98
240	2.40	270	2.70	300	3.00
243	2.43	273	2.73		
245	2.45	275	2.75		

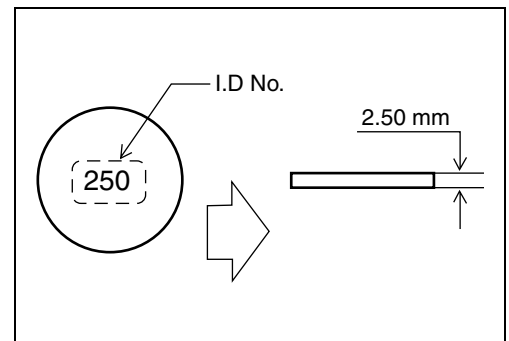

6. Install shim. Identification number should face down (towards tappet).
7. Rotate crankshaft to be open (lift up) valve.
8. Remove tappet holder ① and tighten camshaft housing bolts to specified torque.

 **Camshaft housing bolt: 12 N·m (1.2 kg·m, 8.7 lb·ft)**

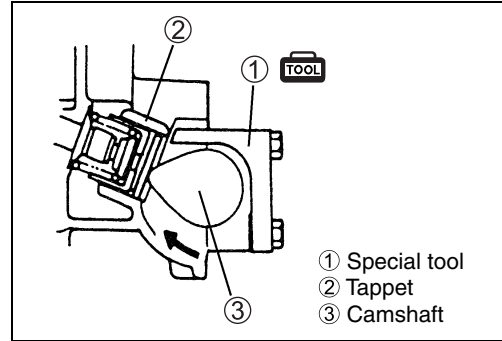

9. Recheck tappet clearance.

NOTE:

After completing tappet clearance adjustment and securing camshaft housing bolts, inspect tappet clearance again.

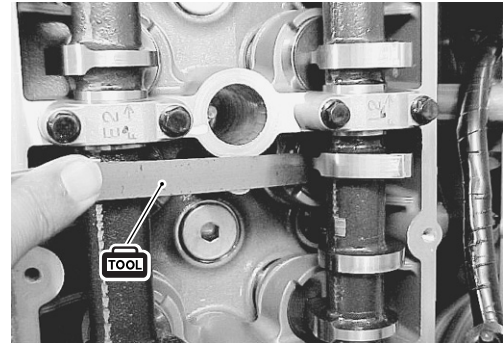

REASSEMBLY

After checking and adjusting all valves, reinstall parts removed earlier.

Installation is reverse order of removal.

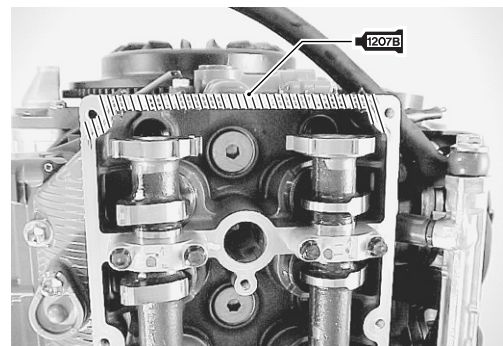

Cylinder head cover

Install the cylinder head cover. (See page 6-13.)

NOTE:

Examine cylinder head cover gasket for damage. Always replace gasket if sealing performance is suspect.

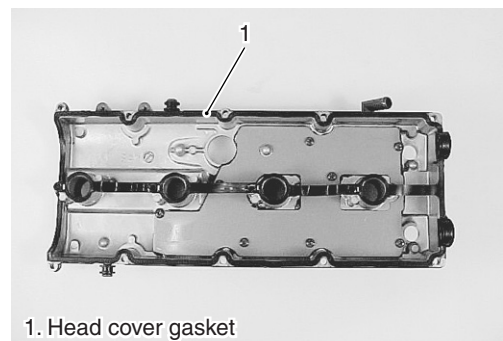
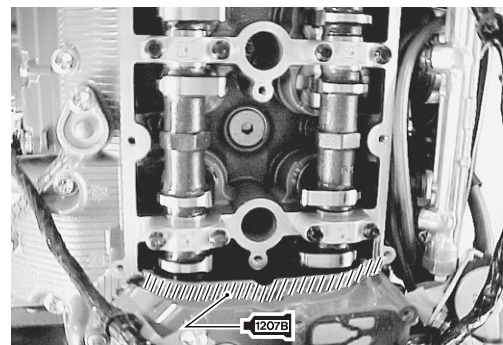

1. Head cover gasket

- Tighten cylinder head cover bolts to specification.

 **Cylinder head cover bolts: 11 N·m (1.1 kg·m, 8.0 lb-ft)**

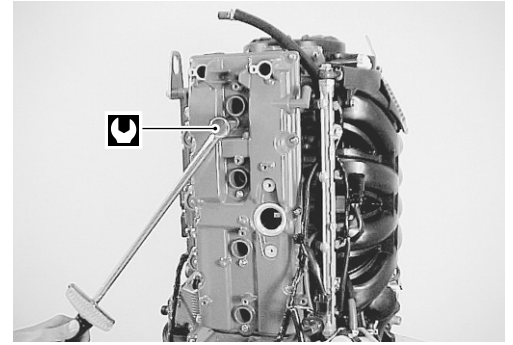

OCV (Oil control valve)

- Install gasket and OCV, and then tighten bolts securely.

NOTE:

Position the OCV gasket tab as shown the right.

CAUTION

Do not reuse OCV gasket. Always replace with new one.

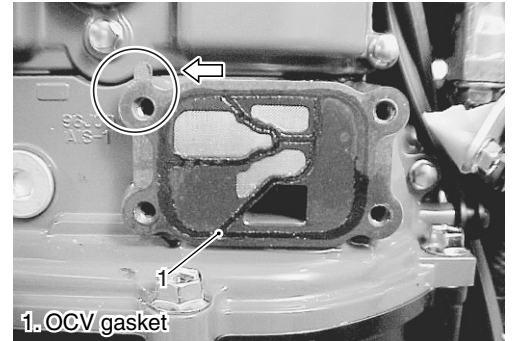

 **OCV bolt: 12 N·m (1.2 kg·m, 8.7 lb-ft)**

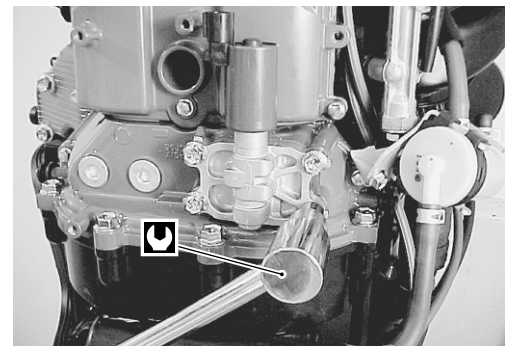

FINAL ASSEMBLY CHECK

- All parts removed have been returned to their original positions.
- Check hose and wire routing. (See page 11-4 to 11-17.)
- Check oil leakage.

TAPPET SHIM SELECTION CHART [IN. side]

Shim I.D. No.	218	220	223	225	228	230	233	235	238	240	243	245	248	250	253	255	258	260	263	265	268	270	273	275	278	280	283	285	288	290	293	295	298	300			
	Present shim size (mm)																																				
Tappet clearance (mm)	2.18	2.20	2.23	2.25	2.28	2.30	2.33	2.35	2.38	2.40	2.43	2.45	2.48	2.50	2.53	2.55	2.58	2.60	2.63	2.65	2.68	2.70	2.73	2.75	2.78	2.80	2.83	2.85	2.88	2.90	2.93	2.95	2.98	3.00			
	Present shim size (mm)																																				
0.00 – 0.04																																					
0.05 – 0.09																																					
0.10 – 0.14																																					
0.15 – 0.19																																					
0.20 – 0.22																																					
0.23 – 0.27																																					
SPECIFIED CLEARANCE / NO. ADJUSTMENT REQUIRED																																					
0.28 – 0.32																																					
0.33 – 0.37																																					
0.38 – 0.42																																					
0.43 – 0.47																																					
0.48 – 0.52																																					
0.53 – 0.57																																					
0.58 – 0.62																																					
0.63 – 0.67																																					
0.68 – 0.72																																					
0.73 – 0.77																																					
0.78 – 0.82																																					
0.83 – 0.87																																					
0.88 – 0.92																																					

1. Measure tappet clearance “Engine cold”.
2. Measure present shim size.
3. Match clearance in vertical column with present shim size in horizontal column.

[EXAMPLE]

Tappet clearance is — 0.35 mm
Present shim size — 2.40 mm
Shim size to be used — 2.50 mm

TAPPET SHIM SELECTION CHART [EX. side]

Shim ID No.	218	220	223	225	228	230	233	235	238	240	243	245	248	250	253	255	258	260	263	265	268	270	273	275	278	280	283	285	288	290	293	295	298	300			
Present shim size (mm)	2.18	2.20	2.23	2.25	2.28	2.30	2.33	2.35	2.38	2.40	2.43	2.45	2.48	2.50	2.53	2.55	2.58	2.60	2.63	2.65	2.68	2.70	2.73	2.75	2.78	2.80	2.83	2.85	2.88	2.90	2.93	2.95	2.98	3.00			
Tappet clearance (mm)																																					
0.00 – 0.04																																					
0.05 – 0.09																																					
0.10 – 0.14																																					
0.15 – 0.19																																					
0.20 – 0.24																																					
0.25 – 0.29																																					
0.30 – 0.34																																					
0.35 – 0.39																																					
0.40 – 0.44																																					
0.45 – 0.49																																					
0.50 – 0.54																																					
0.55 – 0.59																																					
0.60 – 0.64																																					
0.65 – 0.69																																					
0.70 – 0.74																																					
0.75 – 0.79																																					
0.80 – 0.84																																					
0.85 – 0.89																																					
0.90 – 0.94																																					

SPECIFIED CLEARANCE / NO. ADJUSTMENT REQUIRED

1. Measure tappet clearance "Engine cold".
2. Measure present shim size.
3. Match clearance in vertical column with present shim size in horizontal column.

[EXAMPLE]

Tappet clearance is — 0.40 mm
 Present shim size — 2.40 mm
 Shim size to be used — 2.50 mm

IDLE SPEED

Inspect initially after 20 hours (1 month) and every 200 hours (12 months).

NOTE:

- Before checking idle speed, engine must be warmed up.
- Check and/or adjust idle speed after engine speed has stabilized.
- Before checking idle speed, check throttle link mechanism and throttle valve for smooth operation.

1. Remove bolt and No. 1 ignition coil.
2. Connect special tool (H-T cord with plug cap adapter) between No. 1 ignition coil and spark plug.

 **09930-89350: H-T cord with plug cap adapter**

3. Start engine and allow to warm up.
4. Attach engine tachometer to the special tool.

 **09900-26006: Engine tachometer**

5. Check engine speed.

Idle speed (in neutral gear): 600 – 700 r/min.

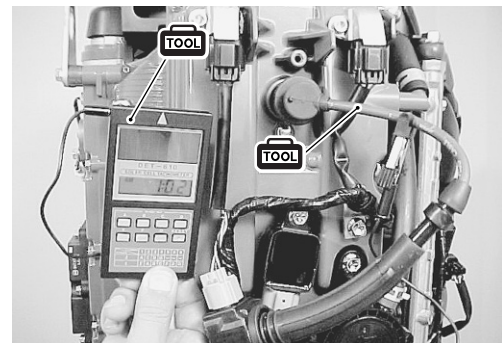
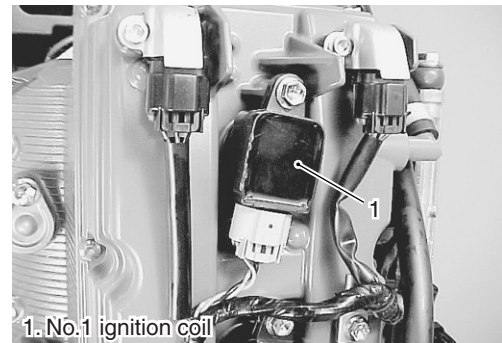

ADJUSTMENT:

If engine idle speed is out of specification, the following adjustment procedure must be performed.

6. Remove the three (3) bolts and fuel hose guard.
7. Shift into Neutral and close the throttle fully (this will cause a full close throttle signal to be input to the ECM).
8. To set the IAC valve duty to constant 10%, turn the ignition key from ON to START five times within ten seconds. At this time, the caution buzzer will sound to notify that IAC duty is in fixed mode.

NOTE:

- The ignition key operation to set the IAC valve into the fixed mode should be performed with the engine running at idle.
- While IAC valve duty is at a fixed 10% duty, the caution buzzer will sound in a repeating pattern of 0.5 second on with an interval of 3 seconds off.
- The 10% fixed mode of IAC valve duty will continue for 5 minutes after which it will automatically cancel.

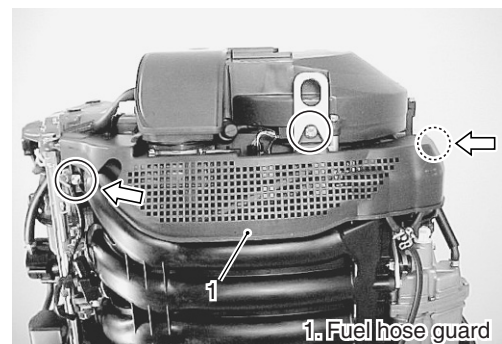

9. During this fixed mode of IAC valve duty, adjust engine speed to 650 ± 50 r/min. by turning by-pass air screw.

Turning air screw counterclockwise:

Engine speed will increase.

Turning air screw clockwise:

Engine speed will decrease.

10. When finished adjusting the idle speed, opening the throttle will automatically cancel the IAC fixed mode.

NOTE:

The fixed mode of IAC can also be canceled manually by shifting to Forward or Reverse or raising the engine speed (changes the TPS full close throttle signal to OFF).

11. Return the throttle to full close and check engine speed. It should now be stable at 600 – 700 r/min.

NOTE:

Idling/trolling speed of 600 – 700 r/min. is controlled by IAC (idle air control) system.

If engine speed does not return to specification, IAC passage may be clogged or IAC system may not be operating correctly.

See "IDLE AIR CONTROL SYSTEM" section on page 3-26.

NOTE:

Trolling speed (in-gear idle speed) is same as idle speed.

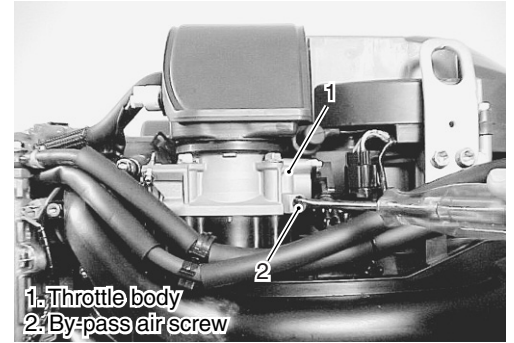

IGNITION TIMING

Inspect every 200 hours (12 months).

NOTE:

Before checking the ignition timing, make sure idle speed is adjusted within specification.

1. Start the engine and allow to warm up.
2. Attach the timing light cord to the No. 1 ignition coil primary wire.

 **09930-76420: Timing light**

3. Check the ignition timing while operating the engine in neutral gear at 1 000 r/min.

Ignition timing: Approx. BTDC 10° at 1 000 r/min.



BREATHER AND FUEL LINE

- Inspect initially after 20 hours (1 month) and every 50 hours (3 months).
- Replace every 2 years.

If leakage, cracks, swelling or other damage is found, replace the breather hose and/or fuel line.

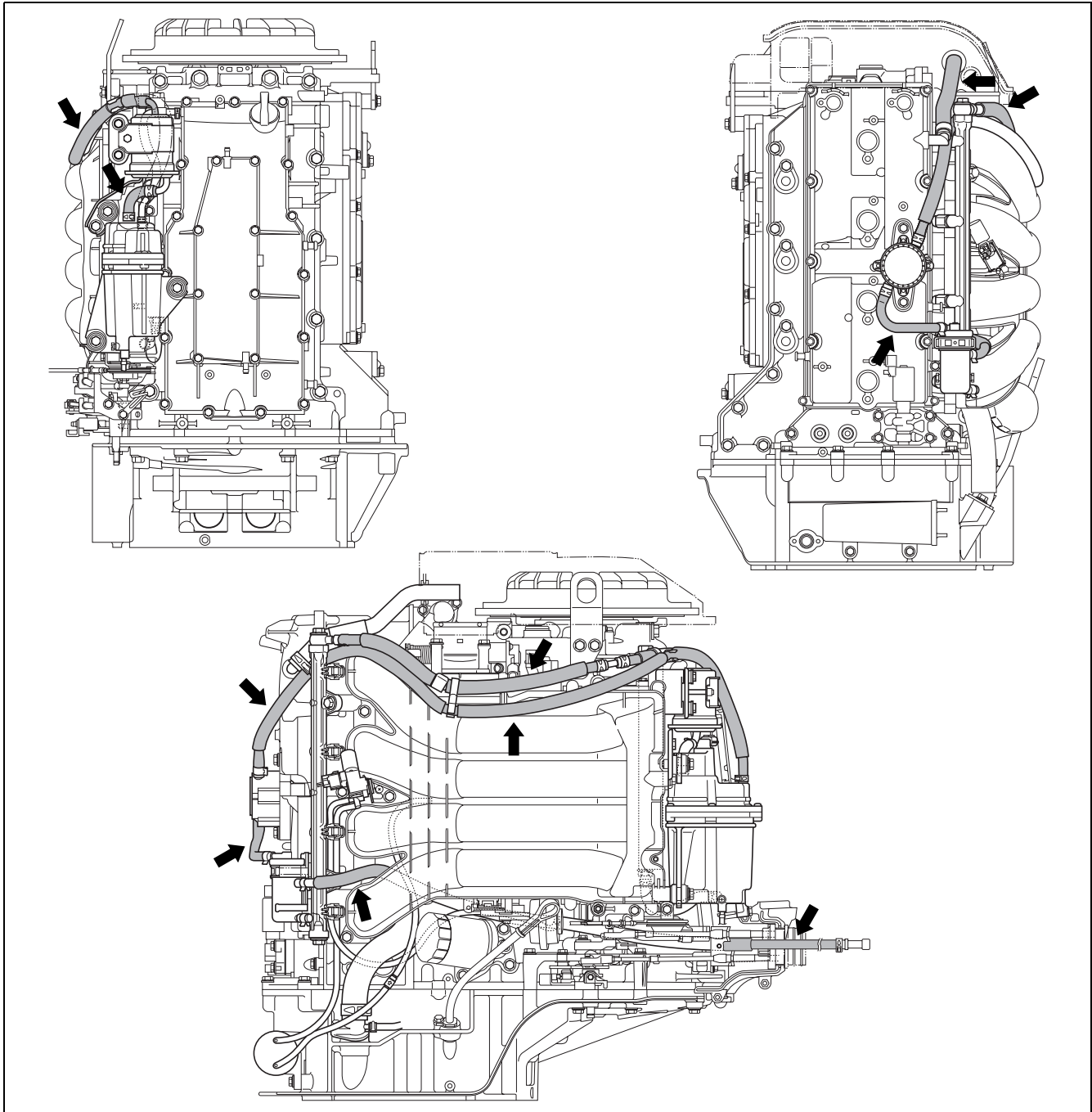

LOW PRESSURE FUEL FILTER

- Inspect before every use.
- Inspect every 50 hours (3 months).
- Replace every 400 hours or 2 years.

If leakage, cracks or other damage is found, replace the fuel filter.

Inspect and Cleaning

⚠ WARNING

- Stop the motor before cleaning the fuel filter.
- Do not smoke and keep open flames and sparks away while working near any part of the fuel system.

1. Turn the engine OFF.
2. To remove the cover ①, pull the upper part outward, then lift up.
3. Disconnect the inlet hose ② and outlet hose ③ from fuel filter ④.
4. Remove the fuel filter from filter bracket ⑤.
5. Remove the cap ⑥, then drain and clean fuel filter.
6. Install the cap, then secure it with clamp ⑦.
7. Install fuel filter to filter bracket properly.
8. Connect the fuel inlet and outlet hose to fuel filter, then secure the fuel hoses to the fuel filter with the hose clamp.
9. Restart the engine and check that there are no leaks around the fuel filter.
10. Install the cover.

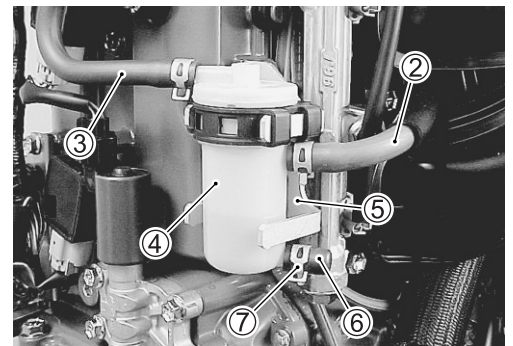
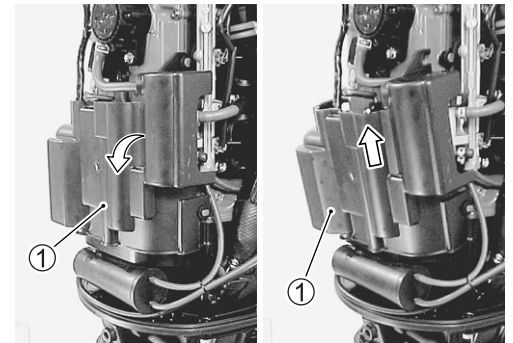
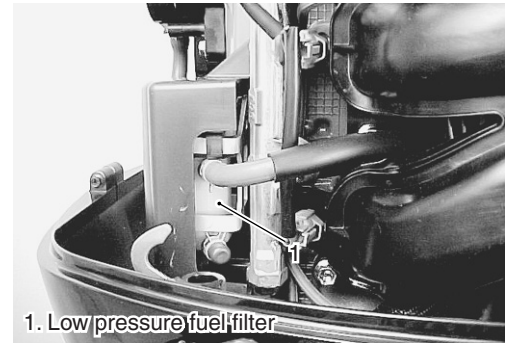

HIGH PRESSURE FUEL FILTER

- Replace every 1 000 hours.

SUZUKI recommends that replacing the high pressure fuel filter every 1 000 operating hours.

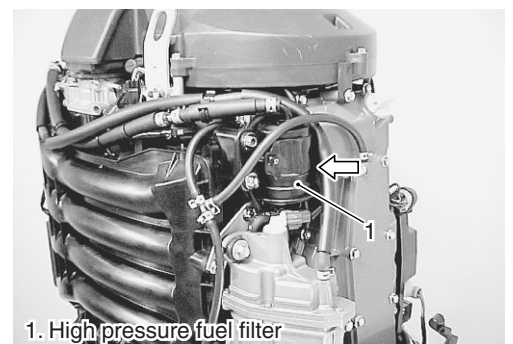

WATER PUMP/WATER PUMP IMPELLER

WATER PUMP

Inspect every 200 hours (12 months).

Inspect water pump case, inner sleeve and under panel.
Replace if wear, cracks, distortion or corrosion is found.

WATER PUMP IMPELLER

Replace every 200 hours (12 months).

SUZUKI recommends that replacing the water pump impeller every 200 hours (12 months).
Inspect water pump impeller.
Replace if vanes are cut, torn or worn.

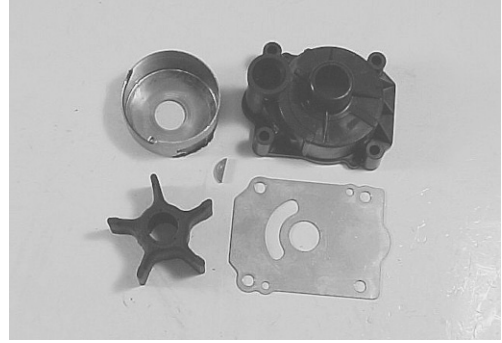

PROPELLER/NUT/COTTER PIN

Inspect initially after 20 hours (1 month) and every 100 hours (6 months).

- Inspect propeller for bent, chipped or broken blades.
Replace propeller if damage noticeably affects operation.
- Inspect propeller splines. Replace propeller if splines are worn, damaged or twisted.
- Inspect propeller bush for slippage.
Replace if necessary.
- Make sure that propeller nut is torqued to specification and cotter pin is installed securely.

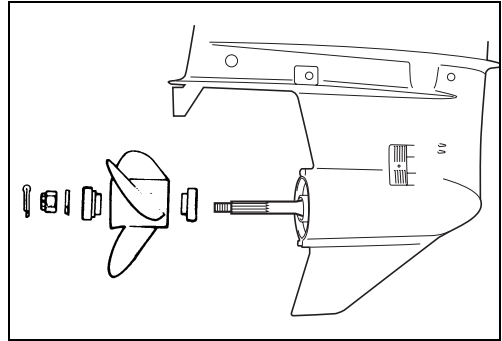

BONDING WIRES

Inspect every 50 hours (3 months).

- If breakage or other damage is found on bonding wire, replace the wire.
- If rust, corrosion or other damage is found on terminal, clean with cleaning solvent or replace wire.

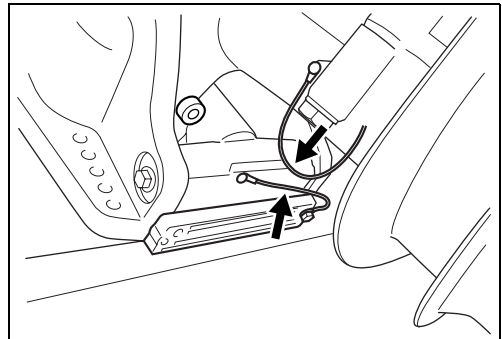

ANODES

Inspect every 50 hours (3 months).

ANODES

If 2/3 of zinc anode has corroded away, replace anode.
 The anode should be periodically cleaned with a wire brush to ensure maximum effectiveness.

NOTE:

The anode cover may be separated from the power unit body by inserting and turning a 10 mm bolt to function as a screw jack.

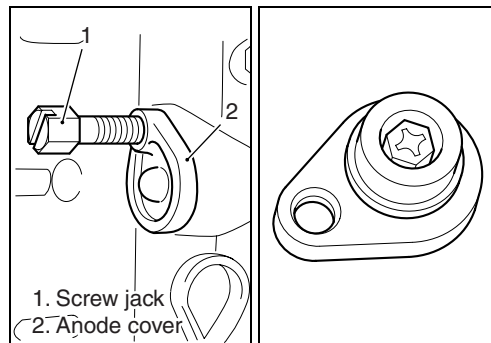
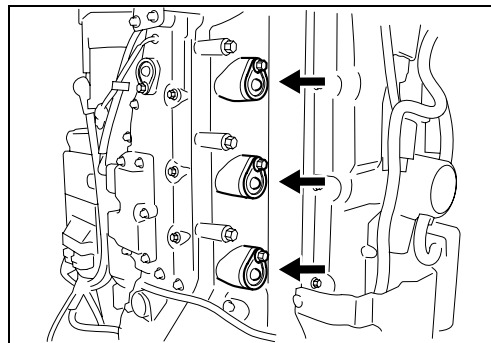

CAUTION

Never paint the anode.

NOTE:

The anode securing bolt should be covered with SUZUKI SILICONE SEAL.

99000-31120: SUZUKI SILICONE SEAL

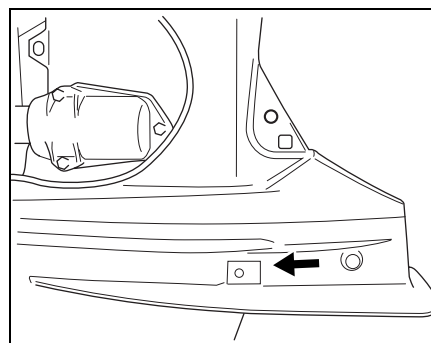
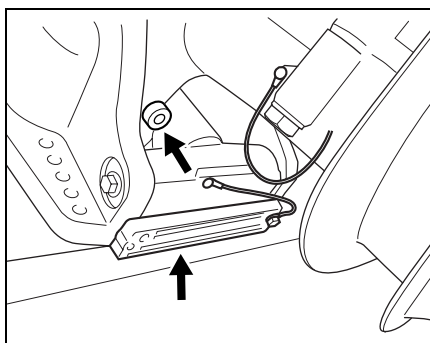
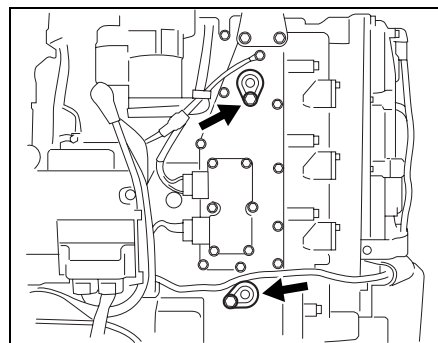
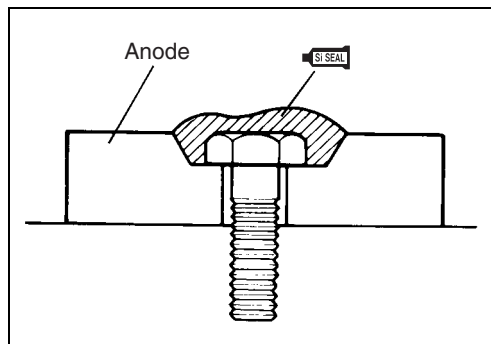

BATTERY

Inspect every 50 hours (3 months).

⚠ WARNING

- Never expose battery to open flame or electric spark as batteries generate gas, which is flammable and explosive.
- Battery acid is poisonous and corrosive. Avoid contact with eyes, skin, clothing, and painted surfaces. If battery acid comes in contact with any of these, flush immediately with large amounts of water. If acid contacts the eyes or skin, get immediate medical attention.
- Batteries should always be kept out of reach of children.
- When checking or servicing the battery, disconnect the negative (black) cable. Be careful not to cause a short circuit by allowing metal objects to contact the battery posts and the motor at the same time.
- Wear approved eye protection.

Recommended battery: 12 V 100 AH (360 kC) or larger

CONNECTING BATTERY

Upon completion of connection, lightly apply grease to battery terminals.

How to connect:

1. Connect positive (+) terminal first.
2. Connect negative (–) terminal second.

How to disconnect:

1. Disconnect negative (–) terminal first.
2. Disconnect positive (+) terminal second.

CAUTION

If the battery leads are loose, incorrectly connected or reversed, the electrical system could be damaged.

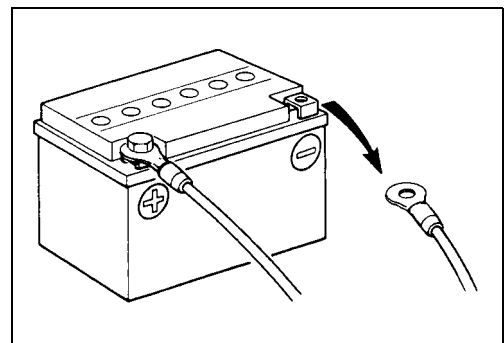
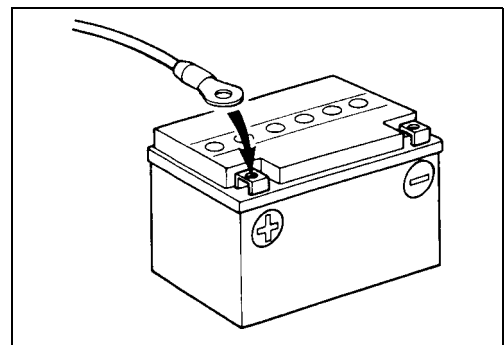

BATTERY SOLUTION LEVEL CHECK

Battery solution level should be between UPPER level and LOWER level.

If level is low, add distilled water only.

CAUTION

Once the battery has been initially serviced, **NEVER** add diluted sulfuric acid or battery damage will occur. Follow the battery manufacturer's instructions for specific maintenance procedures.

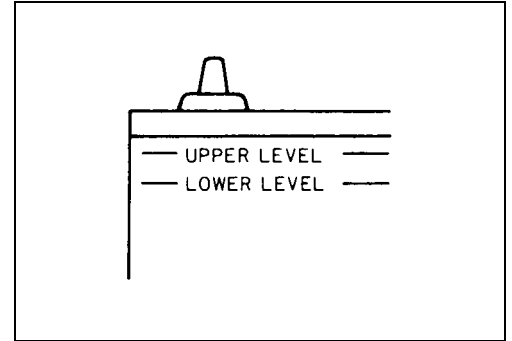
**BATTERY SOLUTION GRAVITY CHECK**

Measure the gravity of battery solution using a hydrometer.

Battery solution gravity: 1.28 at 20 °C

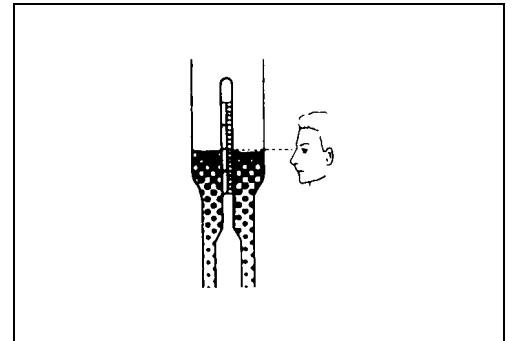

09900-28403: Hydrometer

**BALANCER CHAIN**

Replace every 1 600 hours.

SUZUKI recommends replacing the balancer chain, chain tensioner and chain guide every 1 600 hours.

For balancer chain replacement procedure, see the "POWER UNIT/TIMING CHAIN/BALANCER CHAIN" section on page 6-31 or 6-44.

BOLTS AND NUTS

Inspect initially after 20 hours (1 month) and every 100 hours (6 months).

Check that all bolts and nuts listed below are tightened to their specified torque.

ITEM	THREAD DIAMETER	TIGHTENING TORQUE		
		N·m	kg·m	lb·ft
Intake manifold bolt	8 mm	23	2.3	16.5
Flywheel bolt	12 mm	118	11.8	85.3
Power unit mounting bolt	8 mm	23	2.3	16.5
	10 mm	50	5.0	36.0
Clamp bracket shaft nut	7/8-14 UNF	43	4.3	31.0
Gearcase bolt	10 mm	54	5.5	40.0
	12 mm	83	8.3	60.0
Propeller nut	18 mm	55	5.5	40.0

FUEL MIXTURE CHECK (O2 FEEDBACK)

Perform every 2 years.

To perform fuel mixture check (O2 feedback) operation, a battery powered personal computer and the Suzuki Diagnostic System software/hardware must be used.

For fuel mixture check (O2 feedback) operation, refer to "Suzuki Diagnostic System Operation Manual".

NOTE:

See "O2 FEEDBACK SYSTEM" section on page 3-46 before starting O2 feedback operation.

OIL PRESSURE

Oil pressure (at normal operating temp.):
400 – 600 kPa (4.0 – 6.0 kg/cm², 57 – 85 psi)
at 3000 r/min.

NOTE:

The figure shown above is a guideline only, not an absolute service limit.

If oil pressure is lower or higher than specification, the following causes may be considered.

(See page 6-108 for oil passage locations.)

Low oil pressure

- Clogged oil filter
- Leakage from oil passages
- Defective oil pump
- Defective oil pressure regulator
- Damage O-ring
- Combination of above items

High oil pressure

- Using an engine oil of too high viscosity
- Clogged oil passage
- Clogged oil pressure regulator
- Combination of above items

TEST PROCEDURE

1. Check the engine oil level.
2. Remove the three (3) bolts and fuel hose guard ①.
3. Remove the ring gear cover and air intake silencer case ②.
(See page 6-2.)

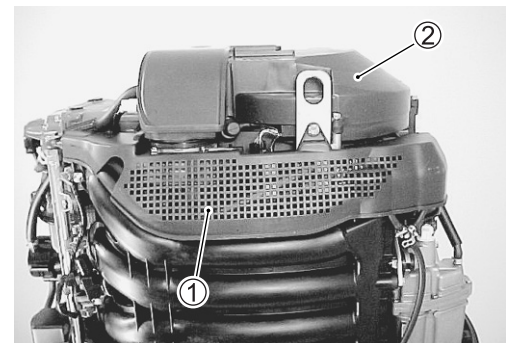

4. Loosen screw and disconnect blue lead wire ③ from oil pressure switch ④.
Remove the oil pressure switch.



5. Install oil pressure gauge adaptor into oil pressure switch hole in place of oil pressure switch.

TOOL 09915-77311: Oil pressure gauge
 09915-78211: Oil pressure gauge adapter

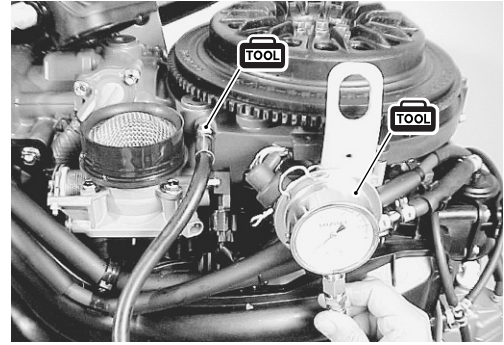

6. Install the ring gear cover and air intake silencer case.
7. Start engine and allow to warm up as follows:
 - Summer : 5 min. at 2 000 r/min.**
 - Winter : 10 min. at 2 000 r/min.**
8. After warming up, shift into forward gear and increase engine speed to 3 000 r/min., then compare pressure indicated on gauge to specifications.
9. After testing, reinstall oil pressure switch.
 (See page 3-70.)

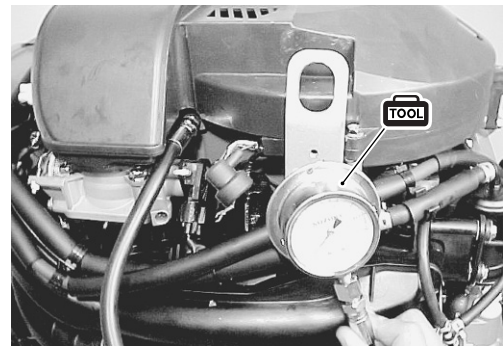
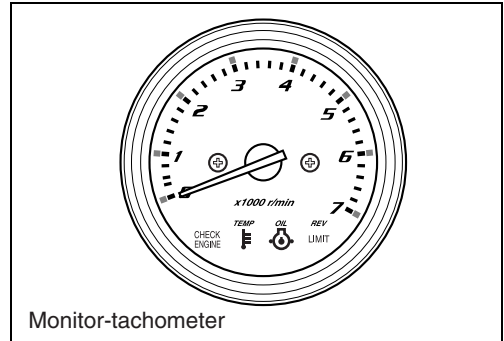

CYLINDER COMPRESSION

Cylinder compression:

Standard: 1 100 – 1 700 kPa
(11 – 17 kg/cm², 156 – 242 psi)

Max. difference between cylinders:
100 kPa (1.0 kg/cm², 14 psi)

NOTE:

Figures shown are guidelines only, not absolute service limits.

Low compression pressure can indicate one or more of following:

- Excessively worn cylinder wall
- Worn piston or piston rings
- Stuck piston rings
- Poor seating of valves
- Ruptured or otherwise damaged cylinder head gasket

TEST PROCEDURE

1. Start engine and allow to warm up, then shut engine off.
2. Disconnect all fuel injector connectors at fuel injector.
3. Disconnect all ignition coil connectors.
4. Remove the bolts securing the ignition coil, then remove all ignition coils and spark plugs.
5. Install compression gauge hose attachment into spark plug hole, then connect compression gauge hose to gauge hose attachment and compression gauge.

-  **09915-64512: Compression gauge**
09915-64530: Compression gauge hose
09915-67010: Compression gauge hose attachment

6. Disconnect remote control throttle cable from throttle lever.
7. Move and hold throttle lever in full-open position.
8. While cranking engine with starter motor, note maximum compression pressure reading on gauge for each cylinder.
9. Reinstall parts removed earlier. (spark plugs, ignition coils, etc.)

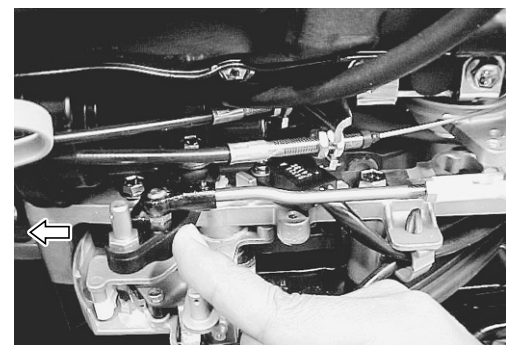
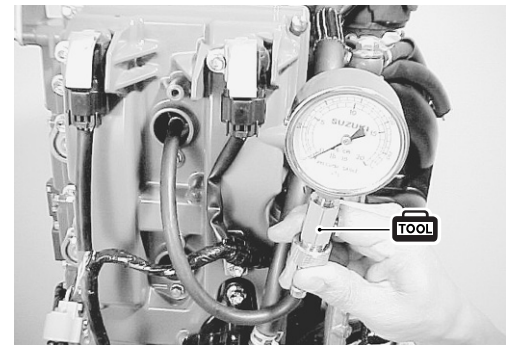
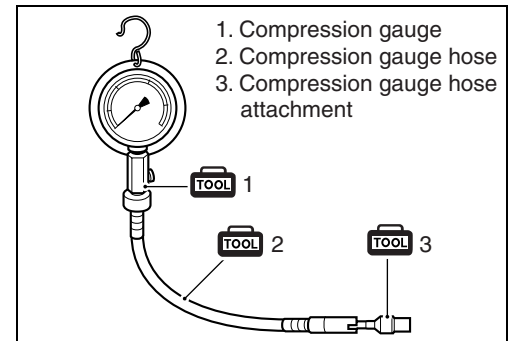

ENGINE VACUUM CHECK

Engine vacuum is required for proper operation of the Multi-Stage Induction system used on the DF150 & DF175. Engine vacuum is also an indicator of general engine condition.

1. Warm up engine to normal operating temperature.
Make sure engine idle speed is within specification.
2. Stop engine and disconnect vacuum outlet hose from check valve.
3. Connect special tools (vacuum gauge, hose and 3-way joint) between engine vacuum hose and check valve.

TOOL 09915-67311: Vacuum Gauge
 09918-08210: Hose joint
 09355-35754-601: Hose
 09367-04002: 3-way joint

4. Start engine and run at idle speed. Vacuum reading on gauge should be within specification.

Vacuum specification

(idle speed at 759.8 mmHg, sea level)

61 – 71 kPa (457 – 533 mmHg, 18 – 21 inHg)

5. If vacuum is not within specification, further testing (leak-down test, compression test, etc.) and evaluation of engine condition is required.

Possible causes of incorrect engine vacuum

- Piston ring leakage
- Incorrect valve timing
- Poor valve/valve seat/valve guide condition
- Intake leakage
- Cylinder head gasket leakage
- Restricted exhaust

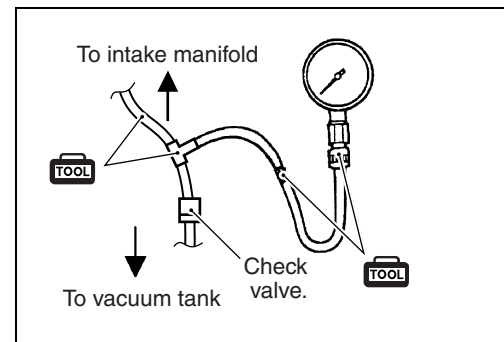

ENGINE CONTROL SYSTEM

CONTENTS

ENGINE CONTROL SYSTEM STRUCTURE	3- 2
SYSTEM STRUCTURE 1	3- 2
SYSTEM STRUCTURE 2	3- 3
COMPONENTS FOR SYSTEM CONTROL	3- 4
ENGINE CONTROL MODULE (ECM)	3- 4
ECM CONNECTOR/TERMINALS LAYOUT	3- 5
ECM INTERNAL STRUCTURE	3- 6
LOCATION OF SENSOR AND SWITCH	3- 7
SENSOR AND SWITCH	3- 9
IGNITION SYSTEM	3-16
IGNITION CONTROL SYSTEM	3-17
ELECTRONIC FUEL INJECTION SYSTEM	3-19
FUEL INJECTION CONTROL SYSTEM	3-19
FUEL DELIVERY SYSTEM COMPONENTS	3-21
HIGH PRESSURE FUEL PUMP CONTROL SYSTEM	3-24
AIR INTAKE COMPONENTS	3-25
IDLE AIR CONTROL SYSTEM	3-26
MULTI-STAGE INDUCTION	3-29
OUTLINE	3-29
SYSTEM COMPOSITION	3-29
SYSTEM OPERATION	3-30
VVT (Variable Valve Timing) SYSTEM	3-32
CAUTION SYSTEM	3-34
OVER-REVOLUTION CAUTION SYSTEM	3-34
LOW OIL PRESSURE CAUTION SYSTEM	3-35
OVERHEAT CAUTION	3-36
LOW BATTERY VOLTAGE CAUTION SYSTEM	3-37
SELF-DIAGNOSTIC SYSTEM	3-38
PRIORITY/CODE/PATTERN FOR SELF-DIAGNOSTIC	
SYSTEM OPERATION	3-38
CONDITION FOR SELF-DIAGNOSTIC SYSTEM OPERATION	3-40
FAIL-SAFE SYSTEM	3-42
PRE-PROGRAMMED VALUE FOR FAIL-SAFE SYSTEM	3-42
OPERATING HOUR INDICATION SYSTEM	3-43
OIL CHANGE REMINDER SYSTEM	3-44
START-IN-GEAR PROTECTION SYSTEM	3-45
O2 FEEDBACK SYSTEM	3-46
INSPECTION	3-47
PRECAUTION ON SYSTEM INSPECTION	3-47
26-PIN & 34-PIN TEST CORD	3-47
INSPECTION FOR ECM CIRCUIT VOLTAGE	3-48
INSPECTION FOR RESISTANCE	3-51
COMPONENT INSPECTIONS	3-53
MULTI-STAGE INDUCTION	3-63
REMOVAL/INSTALLATION	3-66
FLYWHEEL	3-66
CKP SENSOR	3-68
CMP SENSOR	3-69
IAC VALVE	3-69
OIL PRESSURE SWITCH	3-70
OCV (Oil control valve)	3-71
TROUBLESHOOTING	3-72

ENGINE CONTROL SYSTEM STRUCTURE

The DF150/DF175 models employ an integrated control system which performs the control functions for fuel injection, ignition, idle/trolling speed (idle air), etc. through the ECM (Engine Control Module).

SYSTEM STRUCTURE 1

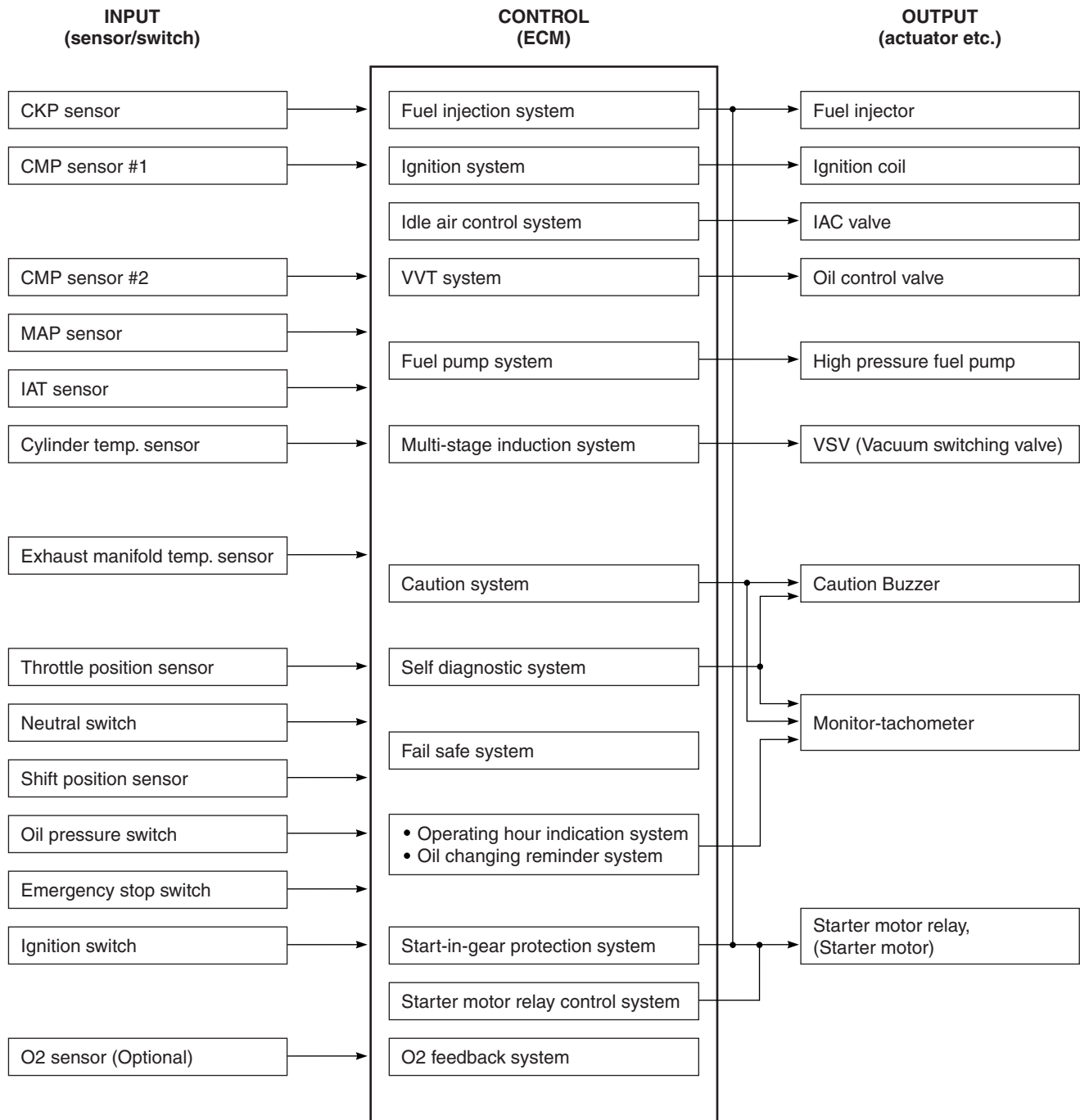

NOTE:

- DF150 model is not equipped with CMP sensor #2 and VVT system.

SYSTEM STRUCTURE 2

[DF150/175]

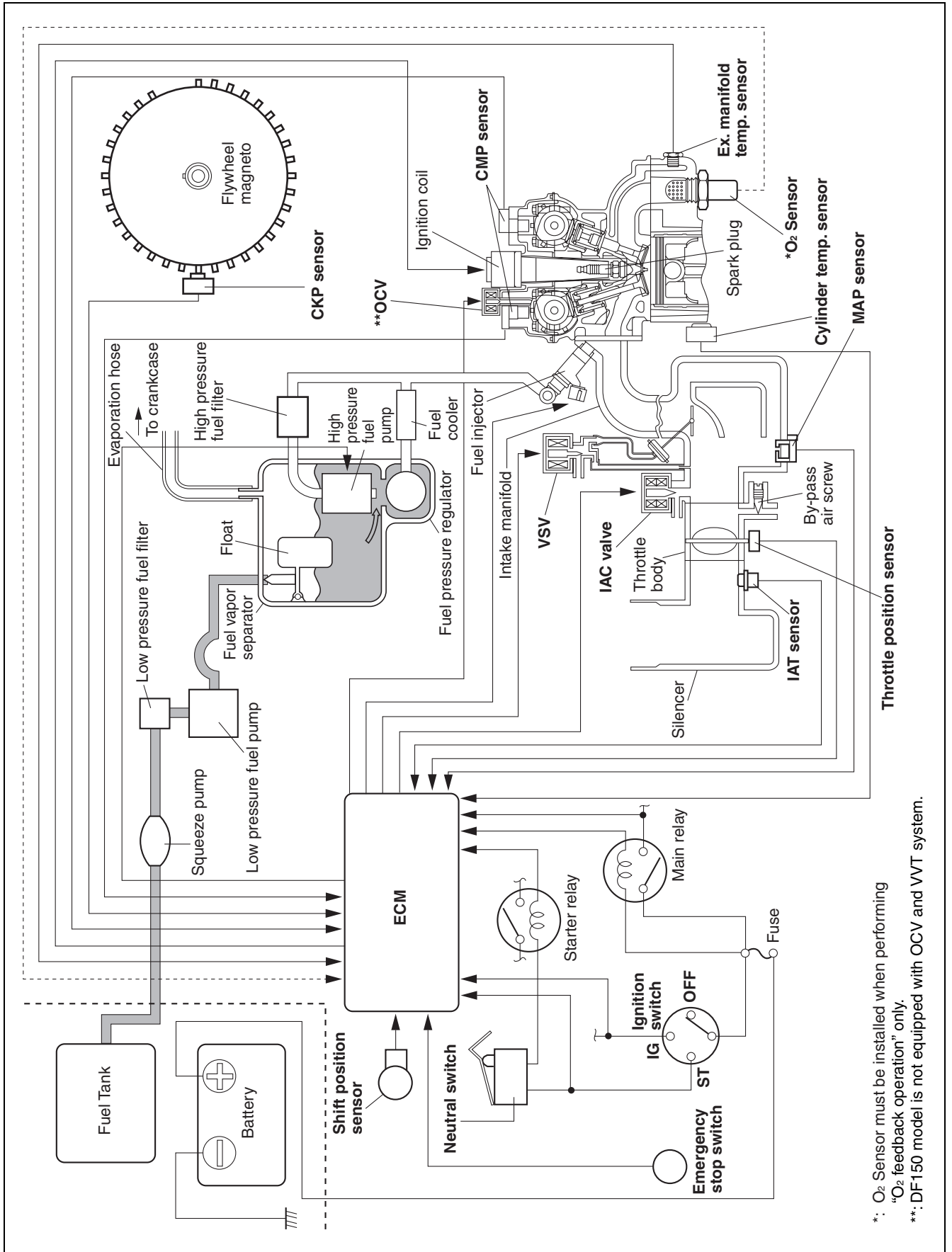

*: O₂ Sensor must be installed when performing "O₂ feedback operation" only.
 **: DF150 model is not equipped with OCV and VVT system.

COMPONENTS FOR SYSTEM CONTROL

ENGINE CONTROL MODULE (ECM)

The ECM sends signals to control the actuators based on the information inputs from each sensor/switch. Major controls are as follows:

NAME OF CONTROL	DESCRIPTION
Fuel injection control	<ul style="list-style-type: none"> Controls fuel injection amount and timing.
Ignition control	<ul style="list-style-type: none"> Controls ignition timing.
Idle air control	<ul style="list-style-type: none"> Controls idling/trolling speed by adjusting intake air amount through IAC valve.
VVT system	<ul style="list-style-type: none"> Controls intake cam valve timing through OCV (Oil control valve).
Fuel pump control	<ul style="list-style-type: none"> Controls high pressure fuel pump drive.
Multi-stage induction system	<ul style="list-style-type: none"> Changing the length of intake manifold pipes according to engine speed.
Caution system control	<ul style="list-style-type: none"> Informs operator of abnormal engine condition. Controls engine speed.
Self-diagnostic system control	<ul style="list-style-type: none"> Informs operator of sensor/switch malfunction.
Fail-safe system control	<ul style="list-style-type: none"> Allows operation with back-up system during sensor/switch malfunction.
Total operating hour indication system control	<ul style="list-style-type: none"> Informs operator of total operating time.
Oil changing reminder system control	<ul style="list-style-type: none"> Informs operator of time for replacing engine oil on the basis of the maintenance schedule.
Start-in-gear protection system control	<ul style="list-style-type: none"> Prevents engine start when shift is positioned in forward or reverse.
Starter motor relay control system	<ul style="list-style-type: none"> Prevents starter motor operation when engine is already operating.
O2 feedback system control	<ul style="list-style-type: none"> Controls and performs O2 feedback operation using optional O2 sensor.

NOTE:

Information related to the Caution system, Self-Diagnostic System, Total operating hour indication system and O2 feedback system is retained in ECM memory.

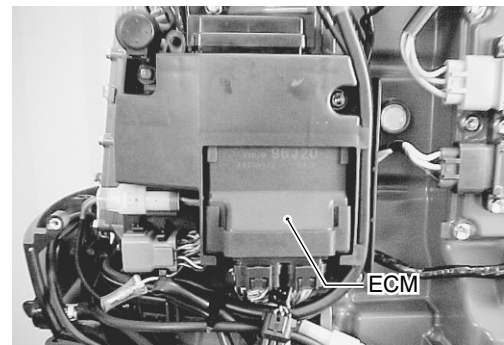

ECM CONNECTOR/TERMINALS LAYOUT

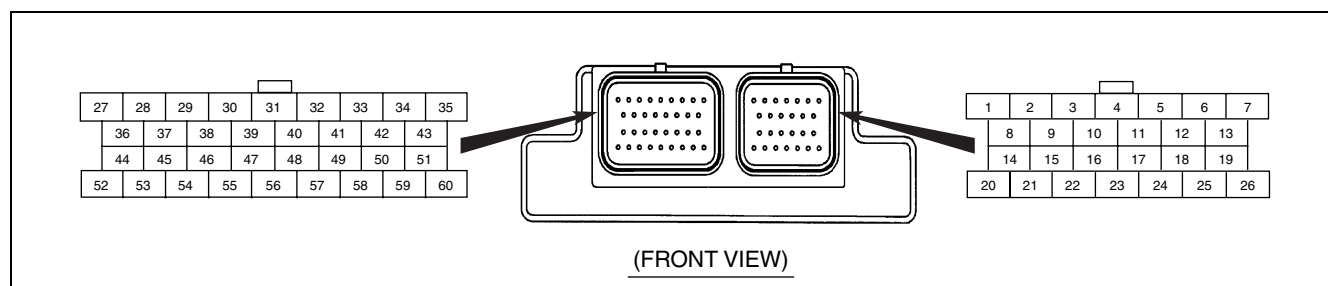

TERMI- NAL	WIRE COLOR	CIRCUIT
1	G	Starter relay control
2	B/G	O2 Feedback
3	—	—
4	R/B	CKP sensor
5	Y/Bl	CMP sensor #1
6	—	—
7	O/G	CMP sensor #2 (VVT)
8	V/W	Ex-manifold temp. sensor
9	Lg/W	Cylinder temp. sensor
10	—	—
11	P/Bl	Shift position sensor
12	W	MAP sensor
13	B	Model distinction (DF150 only)
14	R	Power source for sensor
15	Bl/R	Emergency stop switch
16	Br/Y	Throttle position sensor
17	P/B	Ground for ECM main relay
18	Br	Neutral/Cranking switch
19	Bl	Oil pressure switch
20	Gr	ECM power source
21	Y	PC communication
22	O/Y	PC communication
23	B/Bl	Engine switch
24	O	Buzzer cancel
25	Lg/B	IAT sensor
26	—	—
27	—	—
28	R/W	No. 3 Fuel injector (—)
29	—	—
30	—	—

TERMI- NAL	WIRE COLOR	CIRCUIT
31	Br/R	OCV (—)
32	—	—
33	Gr/G	Variable intake control valve (VSV)
34	P/W	Rev-Limit lamp
35	Y/B	Tachometer
36	B/Br	No. 2 Fuel injector (—)
37	—	—
38	—	—
39	Gr/Y	No. 3 Ignition coil
40	—	—
41	—	—
42	O	No. 1 Ignition coil
43	Bl/W	Buzzer
44	—	—
45	Lg/R	No. 4 Ignition coil
46	B	Ground for power
47	B	Ground for power
48	B	Ground for ECM
49	B/W	Ground for sensor
50	Bl	No. 2 Ignition coil
51	Bl/B	Oil lamp
52	B/R	High pressure fuel pump (—)
53	Lg	No. 4 Fuel injector (—)
54	O/B	No. 1 Fuel injector (—)
55	W/B	IAC valve #1
56	R/Y	IAC valve #2
57	W/Bl	IAC valve #4
58	R/G	IAC valve #3
59	G/W	CHECK ENGINE lamp
60	G/Y	TEMP lamp

ECM INTERNAL STRUCTURE

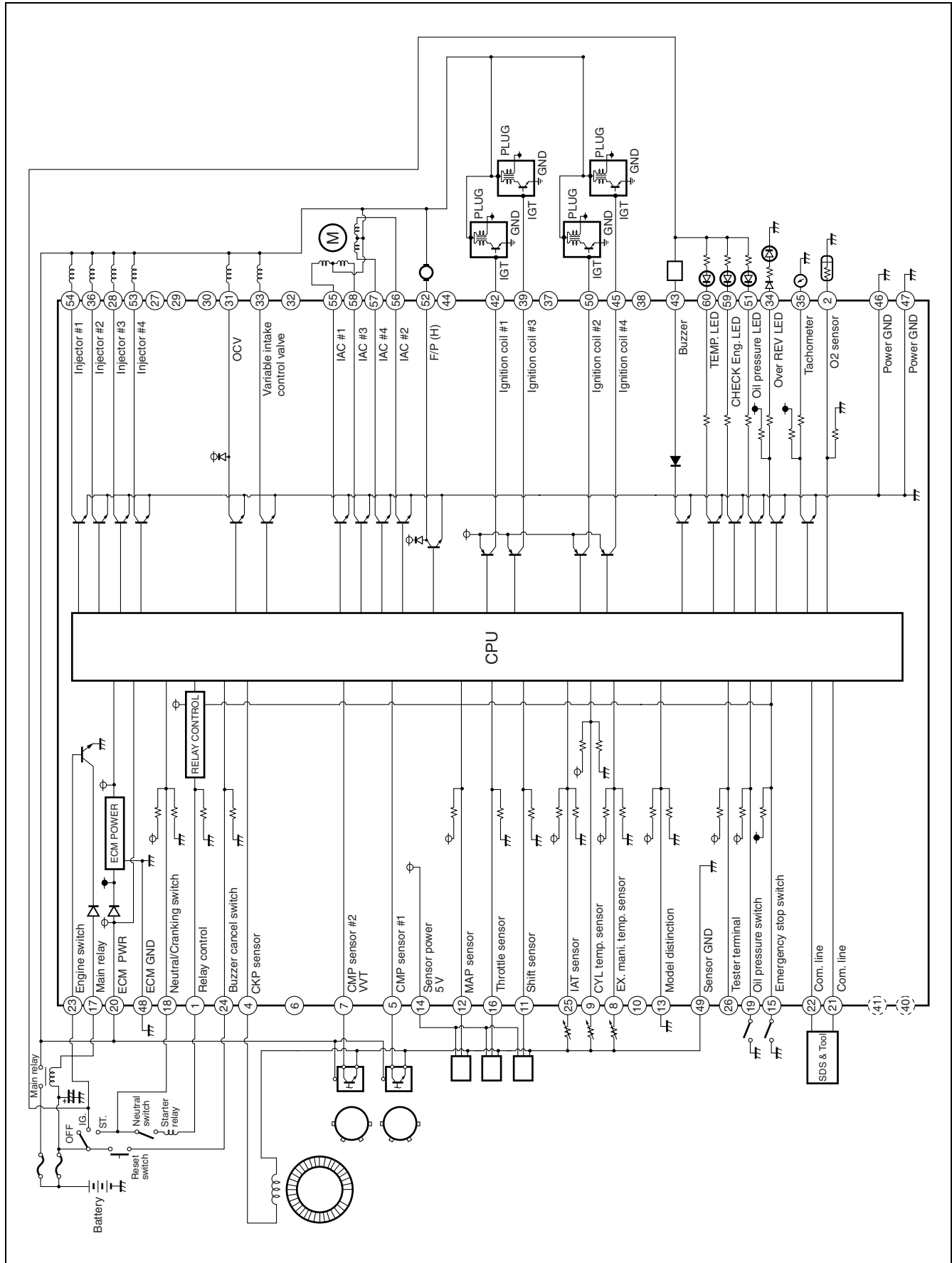

LOCATION OF SENSOR AND SWITCH

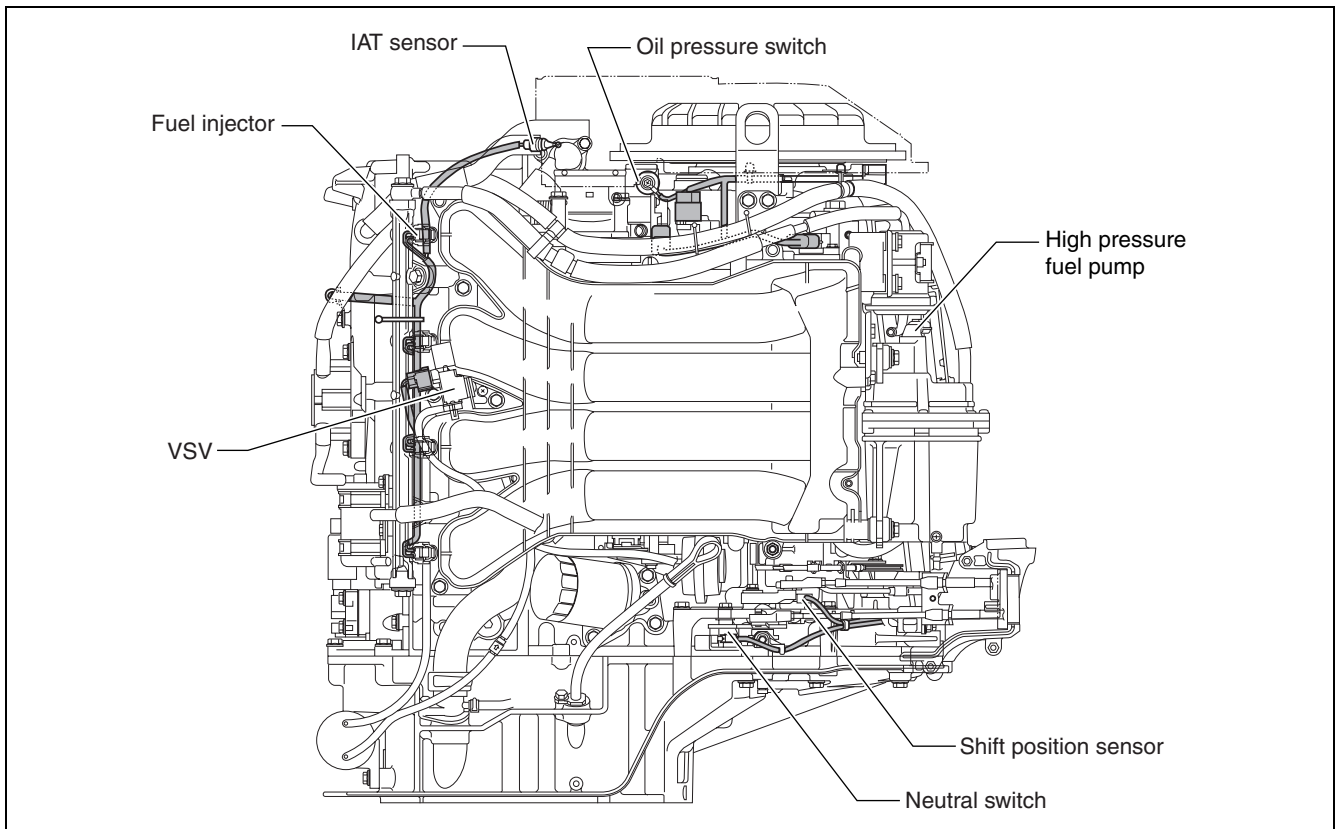
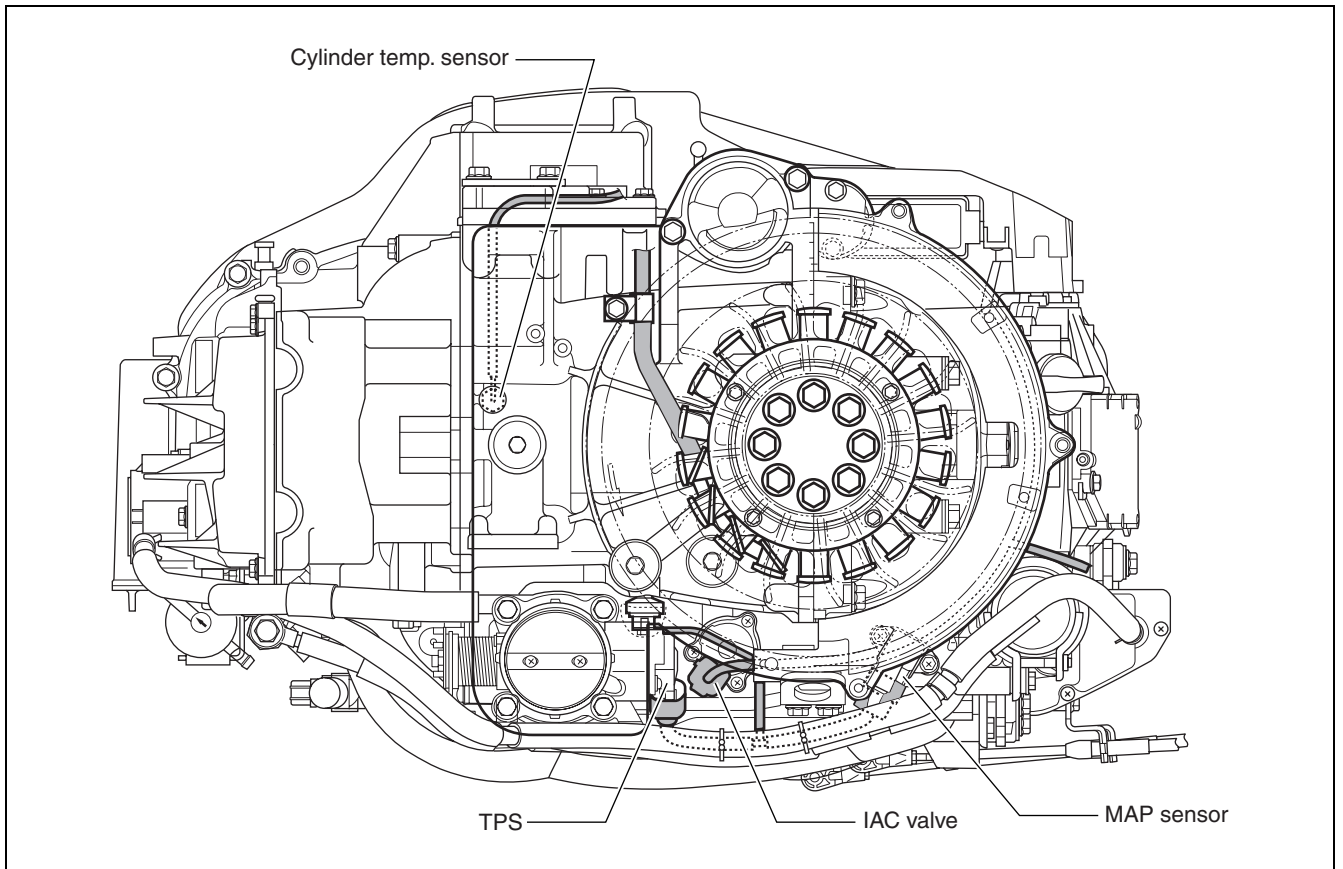

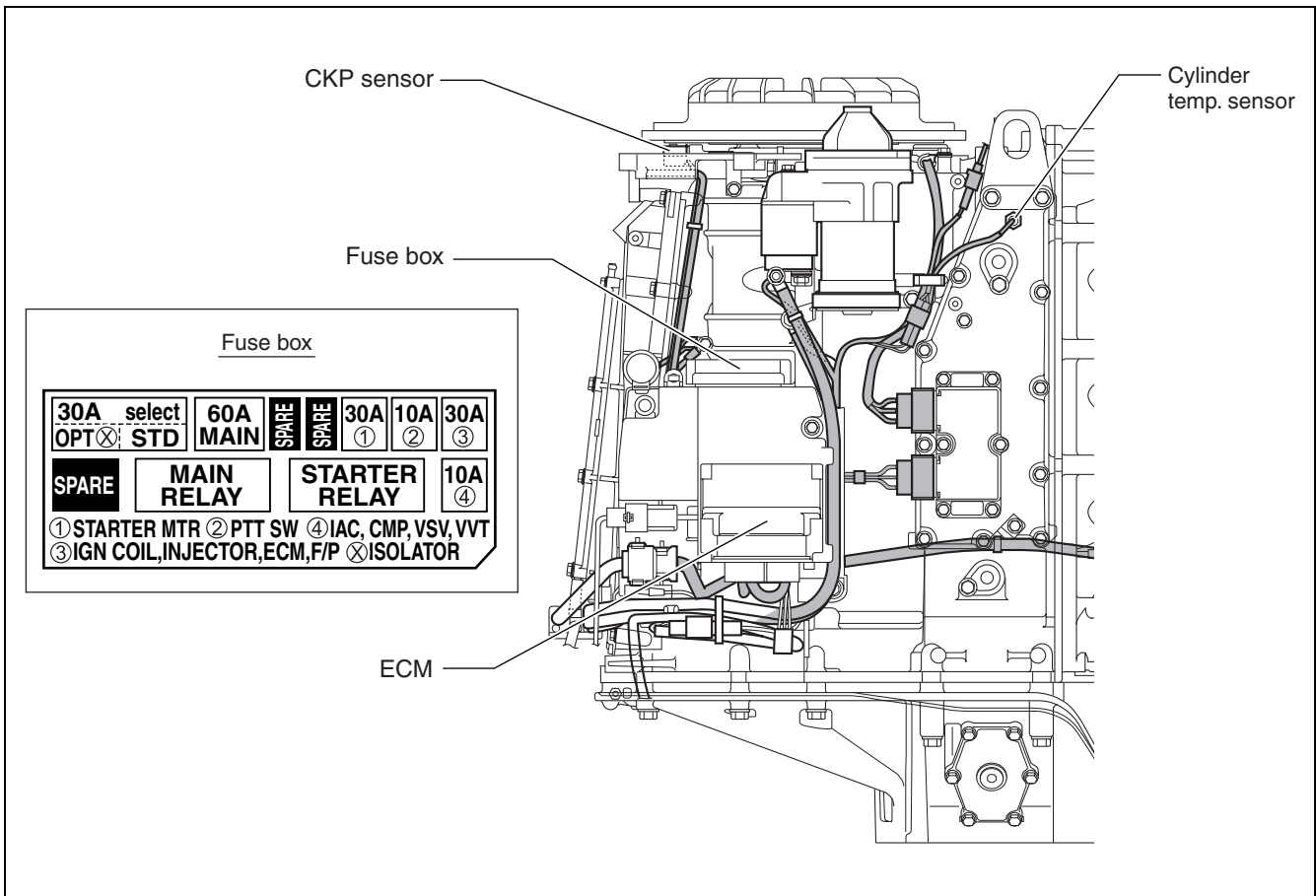
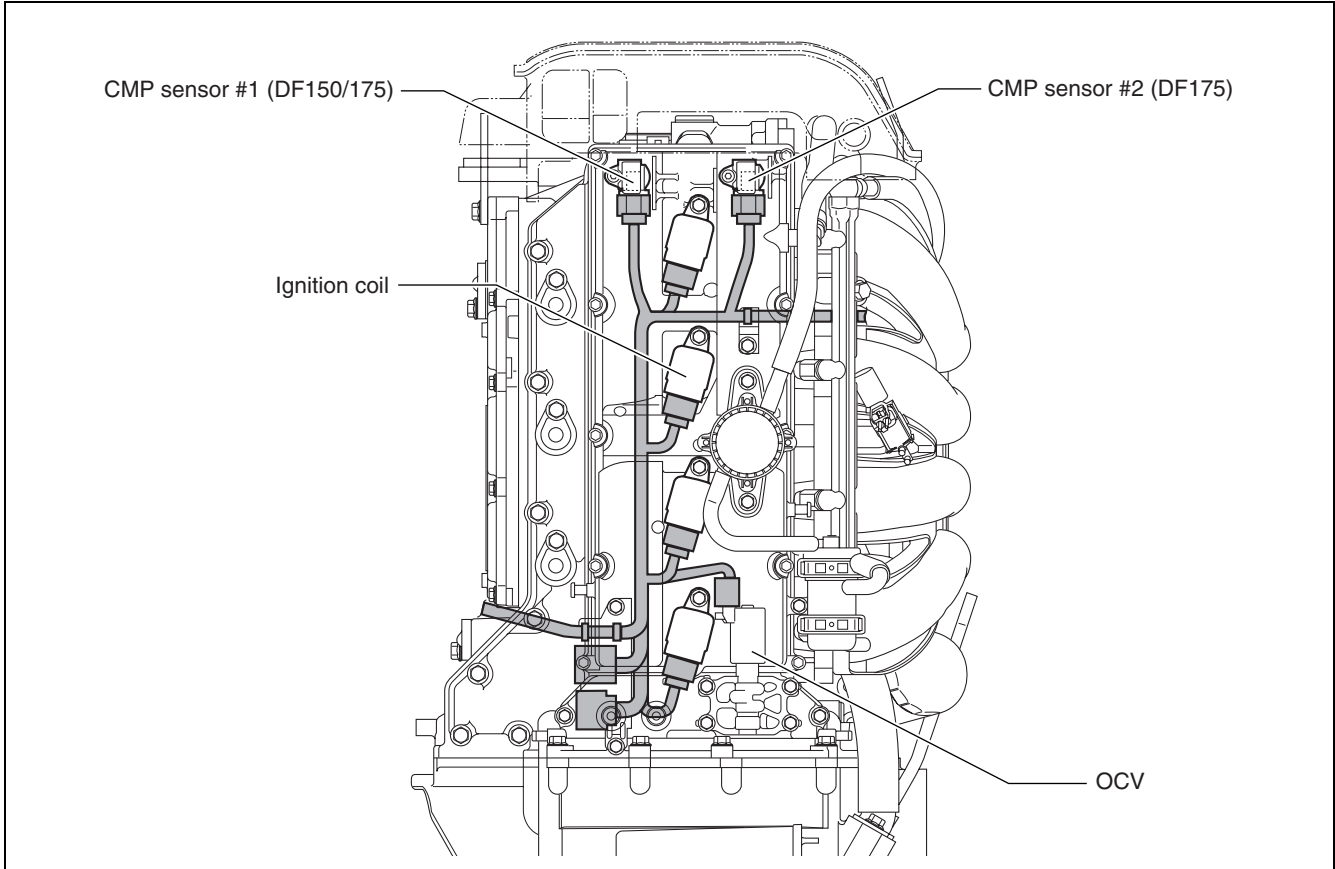

SENSOR AND SWITCH

CKP (Crankshaft Position) SENSOR

There is one (1) CKP sensor installed below the flywheel rotor. When the reluctor bars on the flywheel pass the sensor, a signal (voltage pulse) is generated and sent to the ECM.

This is the fundamental signal used to judge engine speed and crankshaft angle.

There are 34 reluctor bars, spaced 10 degrees apart, followed by a 20 degree index space. During one crankshaft rotation, 34 signals are input to the ECM.

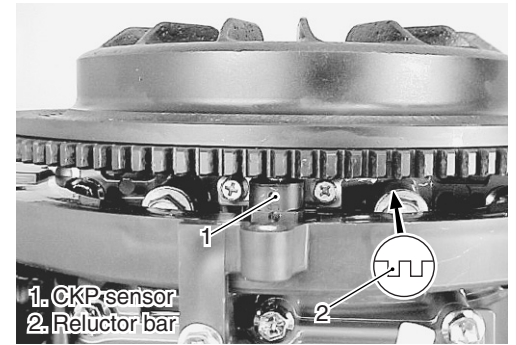

CMP (Camshaft Position) SENSOR #1

- CMP sensor #1 is mounted on the cylinder head cover with trigger vanes pressed onto the end of the exhaust camshaft. This sensor detects piston position.
- Signals received from this sensor are also used by the ECM to determine sequential fuel injection and ignition control.

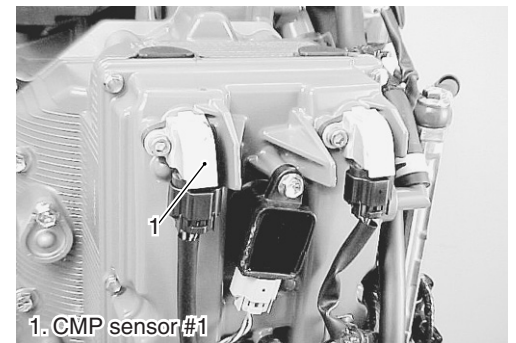

- The CMP sensor contains a “Hall Effect” semiconductor and a magnet. The semiconductor generates a voltage in proportion to the line of magnetic force passed through it. When a trigger vane on the camshaft reluctor aligns with the sensor’ internal magnet, a large amount of magnetic force is generated allowing a high voltage to pass through the semiconductor. When the trigger vane moves away from the sensor, no magnetic force is generated and low voltage passes through the semiconductor.

These generated voltages are rectified to create “ON” (high voltage) & “OFF” (low voltage) signals to the ECM.

- The ten camshaft trigger vanes provide ten high voltage signals from CMP sensor to ECM during one camshaft rotation (two rotations of crankshaft).

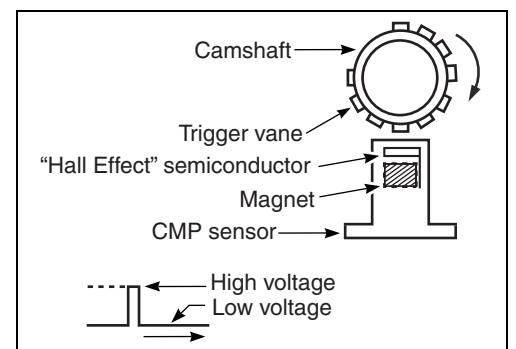

ECM cylinder identification:

Cylinders are identified by a calculation combined from two signals; one from the CKP sensor and one from the CMP sensor.

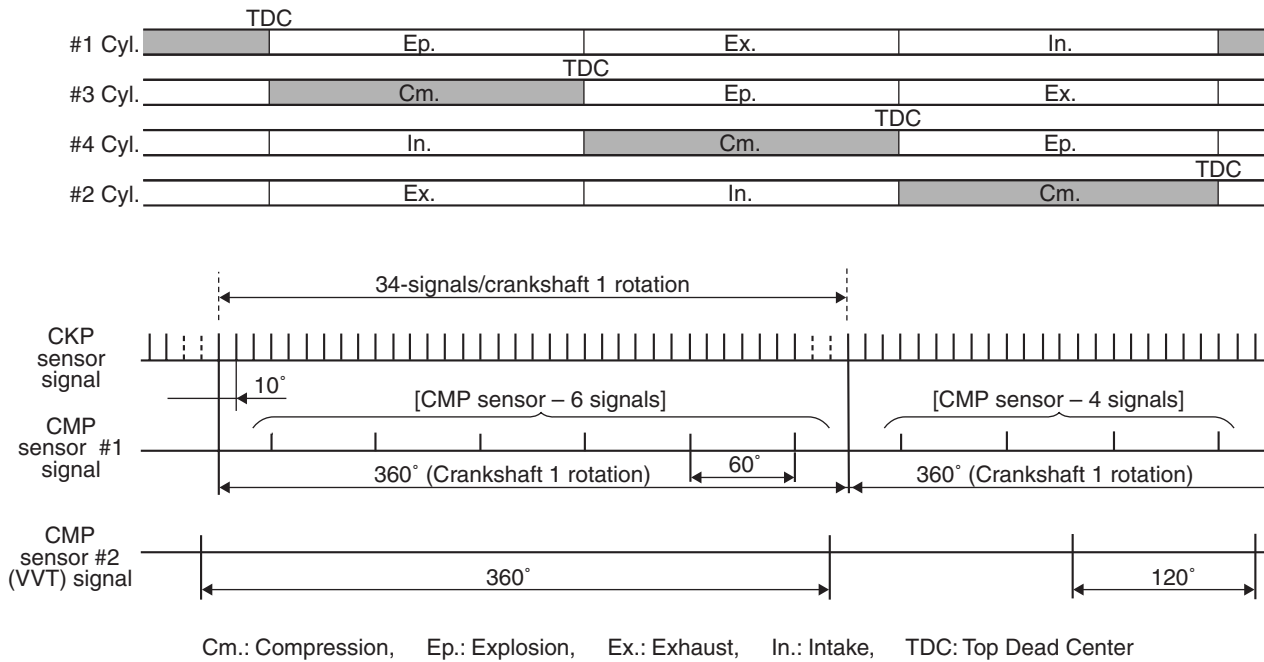

CMP (Camshaft position) SENSOR #2

- For DF175 model:
 CMP sensor #2 is mounted on the cylinder head cover with trigger vanes pressed onto the end of the intake camshaft. This sensor detects camshaft position.
- This sensor is the same type as the CMP sensor #1, and inputs signals to ECM. This signal is used to control intake camshaft valve timing through OCV (Oil control valve).

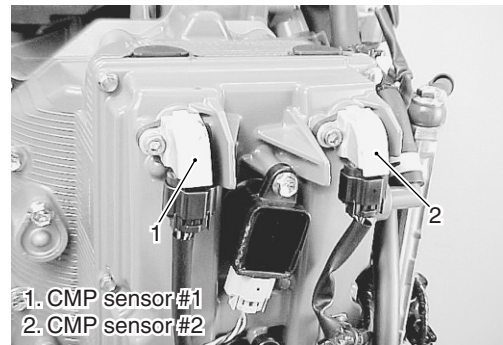

CYLINDER TEMPERATURE SENSOR

The cylinder temperature sensor is installed on the cylinder (top side) and used to detect the cylinder temperature.

This is a thermistor type sensor (resistance of which changes depending on temperature) and inputs a signal to the ECM as a voltage value. This signal is used to compensate the fuel injection time duration, ignition timing, etc.

This sensor is also used to detect engine over-heat as the ECM detects both the temperature and temperature change gradient (temperature rise VS time).

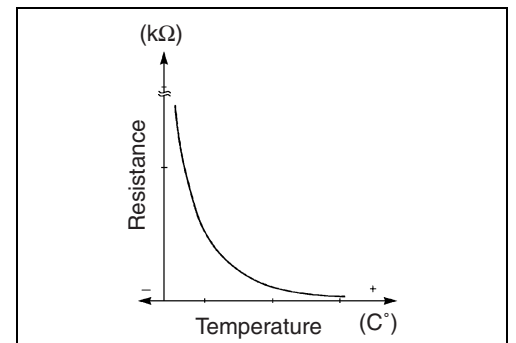
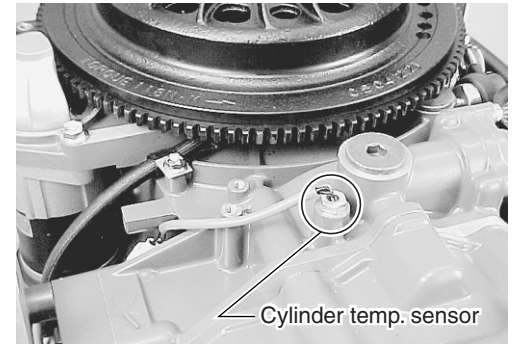

EXHAUST MANIFOLD TEMPERATURE SENSOR

The exhaust manifold temperature sensor is installed on the exhaust manifold and used to detect exhaust manifold temperature.

This sensor is the same type as the cylinder temperature sensor, and inputs a signal to the ECM as a voltage value.

This signal is also used to detect engine over-heat.

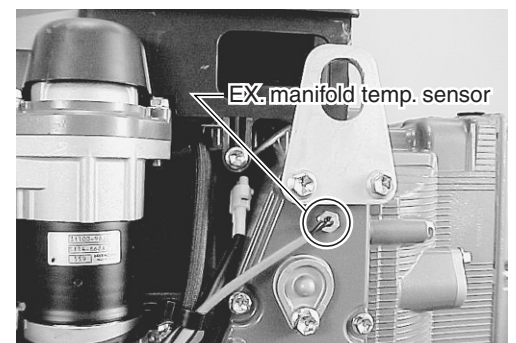

IAT (Intake Air Temperature) SENSOR

The IAT sensor is installed on the air intake silencer case and used to detect the intake air temperature.

This sensor is the same type as the cylinder temperature sensor, and inputs a signal to the ECM as a voltage value.

This signal is used to compensate the fuel injection time duration.



MAP (Manifold Absolute Pressure) SENSOR

The MAP sensor is installed on the intake manifold and used to detect the intake manifold pressure.

It also detects the barometric pressure before starting the engine. This sensor inputs the intake manifold pressure to the ECM as a voltage value.

This input signal is used as the fundamental signal to determine fuel injection time duration, ignition timing, etc.

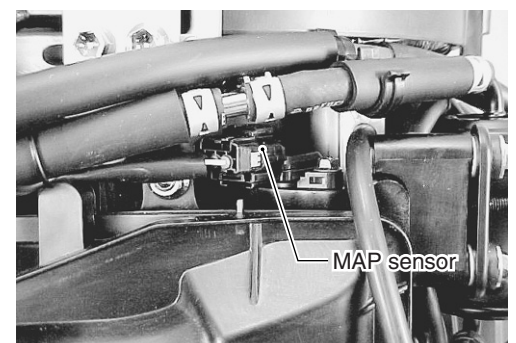

TPS (Throttle Position Sensor)

The TPS is installed on the throttle body and detects the degree of throttle opening. The throttle shaft is interlocked with the TPS shaft.

This sensor is a variable resistor changing resistance (Ohms) in accordance with the throttle opening.

The varying resistance value is converted to voltage and input to the ECM.

Based on the TPS voltage, the ECM calculates the idle position and throttle opening and determines the control modes of various controls systems (Idle air control, VVT system control, Fuel injection control system, etc.).

**NEUTRAL SWITCH**

The neutral switch is installed on the throttle lever holder and used to detect the shift position.

This switch is "ON" in neutral and "OFF" in forward or reverse.

Based on the switch' shift position signal input, the ECM performs the following controls:

- When the shift is in forward or reverse at the time of engine start, no power is supplied to starter motor relay preventing starter motor engagement.

(Start-in-gear protection. See page 3-45.)

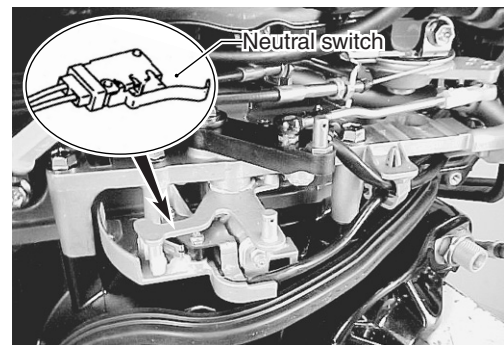
**SPS (Shift Position Sensor)**

The SPS is installed on the throttle lever holder and detects the shift position. The clutch lever is interlocked with the SPS shaft.

This sensor is a variable resistor that changes resistance (ohms) in accordance with the shift position.

The varying resistance value is converted to voltage and input to the ECM.

Based on the SPS voltage, the ECM calculates and determines the change of shift position and executes the following controls.

- When the shift is in neutral, fuel injection is controlled to prevent engine speed from exceeding 3 000 r/min.
- After shifting into forward or reverse from neutral, the IAC valve is controlled to increase intake air for 0.1 second to prevent unstable engine idle or stalling.

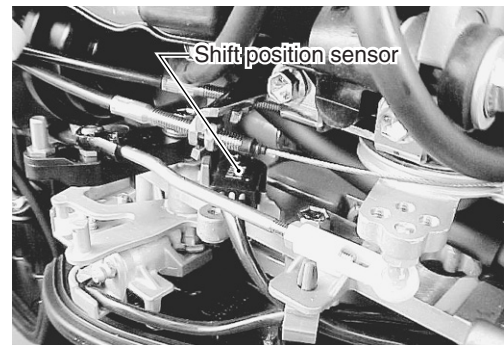

ECM MAIN RELAY

The ECM main relay is installed in the fuse box. When energized by turning the ignition switch ON, a circuit is formed which supplies battery voltage to the ECM, fuel injector, ignition coil, IAC valve, CMP sensor, high pressure fuel pump, OCV (Oil control valve) and VSV (Vacuum switching valve).

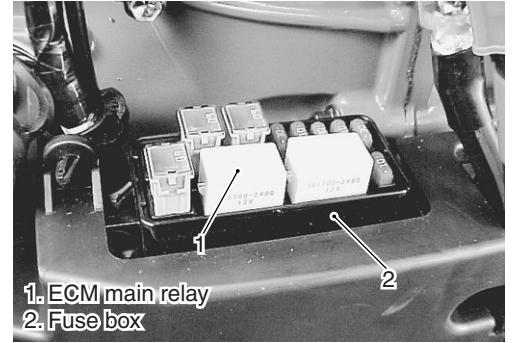

CRANKING SWITCH SIGNAL

The ECM detects the engine being started by the position of ignition switch key. When the ignition key is turned to ST position, a voltage (12 V) signal is input to the ECM.

The ECM in turn controls the actuators for ignition, fuel injection, IAC, etc. to the starting mode.

With the key is turned to IG position after the engine has been started, the input voltage becomes approx. 1.4 V.

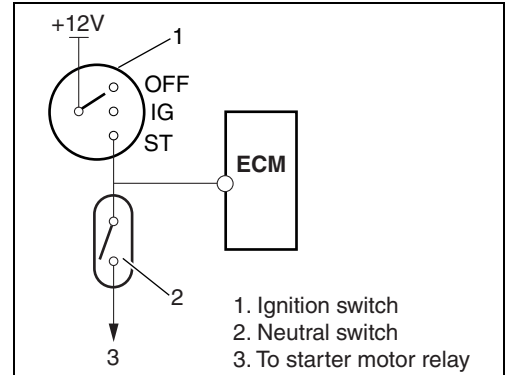

SUB BATTERY CABLE (ECM POWER SOURCE LINE)

The ECM is battery dependent and must be provided with its own dedicated 12V power supply. The electrical circuits which provide this supply are:

1. The sub battery cable to the white lead wire in the remote control extension harness to the ignition switch.

When the ignition switch is turned ON, battery power passes from the white lead wire, through the ignition switch contacts to the gray output lead wire to the No.23 terminal of ECM.

NOTE:

Ensure battery cable connections are clean and secure.

Failure at the battery connection will cause incorrect operation of the ECM and starter motor cranking system.

2. The engine wiring harness to the main relay. When the ECM main relay is energized by turning the ignition switch ON, a circuit is formed which supplies battery voltage to the No.20 terminal of ECM.

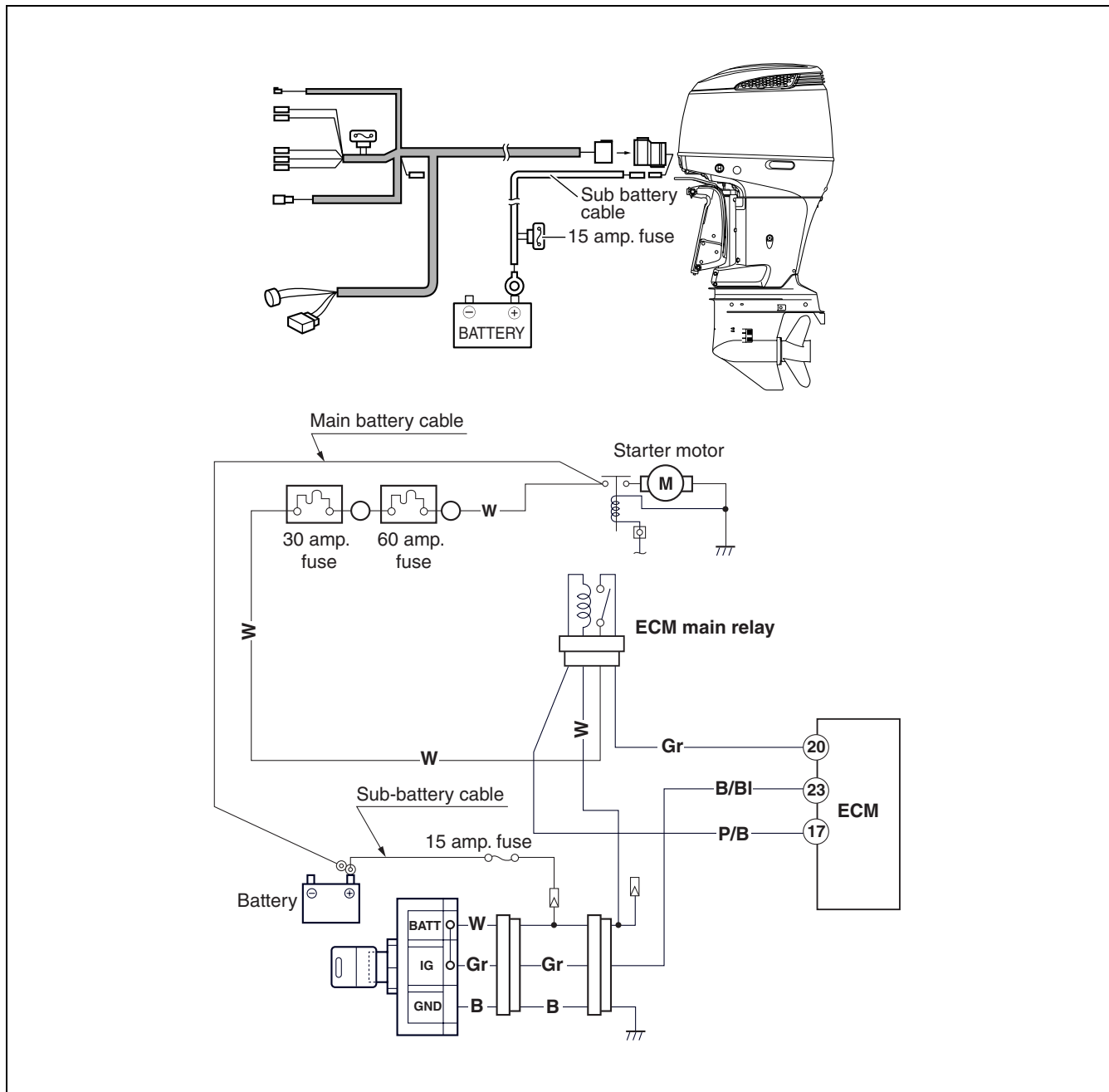

O2 SENSOR (Optional item)

The O2 sensor is installed in the exhaust manifold only when the O2 feedback operation is performed.

This sensor is a zirconia element (platinum plated) which changes output voltage depending on the oxygen concentration difference between its internal and external surfaces. The voltage change reflects the concentration of the oxygen in the exhaust gas and is used to perform the O2 feedback operation.

The terminal voltage change (0 – 1 V) is dependent on the concentration of oxygen in the exhaust gas.

This detected voltage value therefore represents the oxygen concentration. The terminal voltage decreases when the oxygen concentration is high, and increases when it is low.

NOTE:

As the Zirconia element is not conductive below 250 °C, the O2 sensor will not function properly until the engine is at normal operating temperature.

NOTE:**Zirconia element:**

The zirconia element produces a potential difference (voltage) when there is a difference in the oxygen concentration of the gases which contact the two sides of the element.

Since the inner surface of the Zirconia element (inside the sensor) is exposed to atmospheric air and the outer surface exposed to the exhaust gas, there is a difference in oxygen concentration on each side and thus a difference in the potential generated.

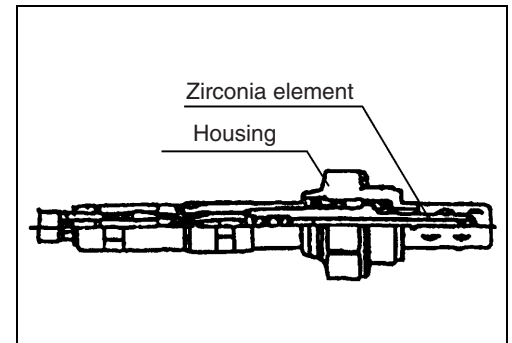

IGNITION SYSTEM

The ignition system used by the DF150/DF175 is a fully transistorized, electronic microcomputer timing advanced type.

This system is totally battery powered, with the ECM controlling all ignition timing functions.

The ignition system is composed of the ignition coil, spark plug and components for system control (ECM, sensor, switch etc.)

When the ignition switch is "ON", battery voltage (12 V) is applied to the circuit as shown in the illustration.

The ECM determines the optimum ignition timing and duration of current flowing through the ignition coil primary winding based on the signals received from various sensors. The ECM interrupts the base current of the power transistor inside the ignition coil thereby controlling current flow (ignition) to the primary winding of ignition coil.

In this way, a mutual induction high voltage occurs in the ignition coil secondary side and spark is generated.

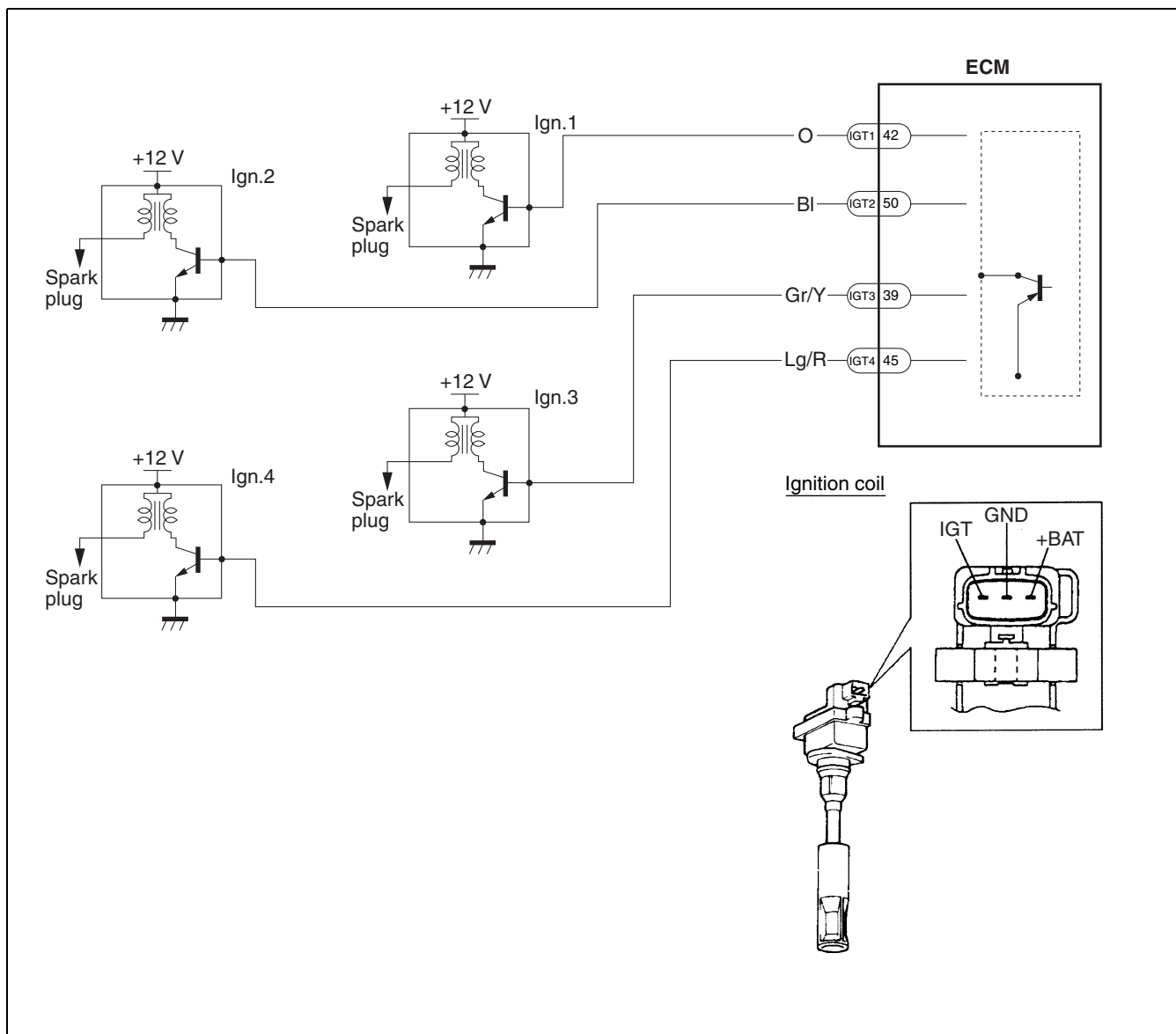

IGNITION CONTROL SYSTEM

OUTLINE

Sensors at specific points on the engine monitor current engine conditions and send signals to the ECM. Based on these signals, the ECM determines the optimum ignition timing and releases voltage to the ignition coils.

Basic sensors

MAP sensor:

Informs ECM of intake manifold pressure.

CKP sensor:

Informs ECM of engine speed and crankshaft angle.

Compensating sensors

Cylinder temperature sensor:

Informs ECM of cylinder temperature.

Throttle position sensor:

Informs ECM of throttle opening angle.

Shift position sensor:

Informs ECM of shift position and change.

Switch

Ignition switch:

Informs ECM of "START" signal.

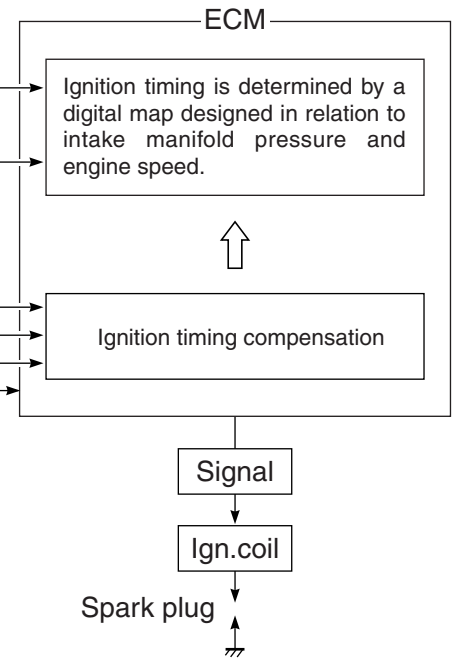

SPECIFICATION

Ignition system	Full-transistorized ignition
Advance	Electronic microcomputer control
Ignition timing	BTDC 5° – BTDC 26° (DF150) BTDC 5° – BTDC 26° (DF175)
Firing order	1 – 3 – 4 – 2

IGNITION TIMING CHART

The following chart is an example for ignition at BTDC 10°.

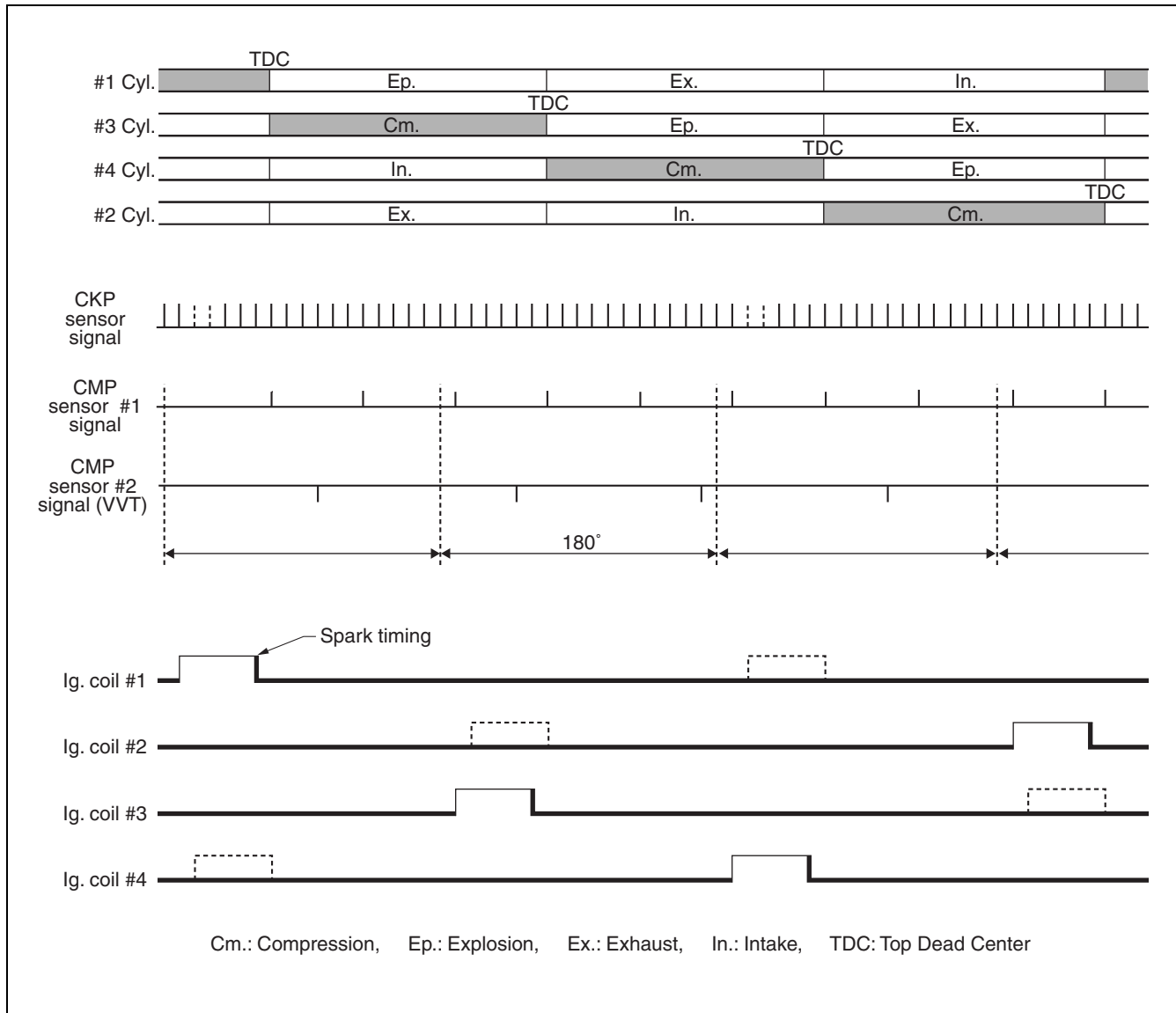

CONTROL MODE

WHEN CRANKING:

The ignition timing is fixed at BTDC 5° until the engine starts.

WHEN IDLING/TROLLING:

The ignition timing is controlled within the range of BTDC 5° ± 5° to provide stable engine operation at the specified idling/trolling speed.

WHEN RUNNING (NORMAL OPERATION):

The ignition timing ranges between BTDC 5° – 26°, depending on current engine operating conditions.

ELECTRONIC FUEL INJECTION SYSTEM

The fuel injection system used by the DF150/DF175 is a speed-density, multi-point, sequential, electronic fuel injection type.

The fuel injection system is composed of the fuel line components, air intake components, and components for system control (ECM, sensors, switches, etc.).

FUEL INJECTION CONTROL SYSTEM

OUTLINE

Sensors are mounted at precise locations on the motor to monitor the current conditions of engine operation and send signals to the ECM. Based on these signals, the ECM determines the optimum fuel injection time duration (fuel amount), fuel injection timing (multi-point sequential timing) and controls the injector operating signals accordingly.

Fuel injection start timing is set at a constant of ATDC 275° on the exhaust stroke.

Basic sensors

MAP sensor: Informs ECM of intake manifold pressure.
CKP sensor: Informs ECM of engine speed and crankshaft angle.

Compensating sensors

Cylinder temperature sensor: Informs ECM of cylinder temperature.
Exhaust manifold temperature sensor: Informs ECM of exhaust manifold temperature.
IAT sensor: Informs ECM of intake air temperature.
TPS (Throttle position sensor): Informs ECM of throttle opening angle.
MAP sensor: Informs ECM of barometric pressure at time of engine start.
Battery voltage: Constantly monitored by the ECM.

Others

CMP sensor: Informs ECM of camshaft angle.
Shift position sensor: Informs ECM of shift position (neutral or in-gear).

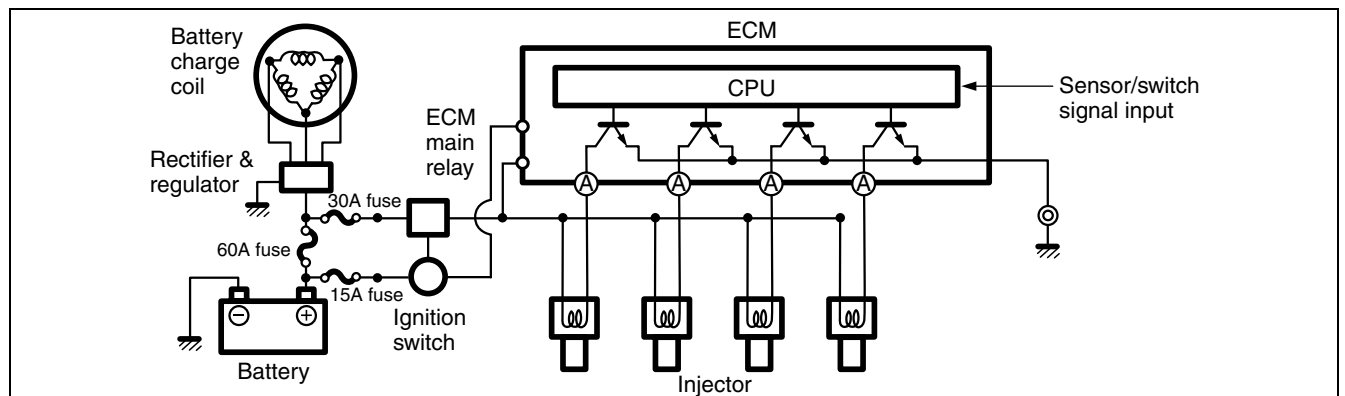
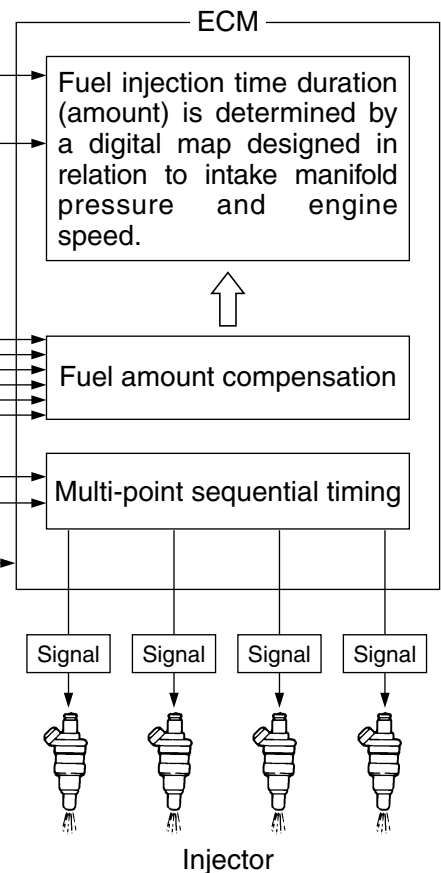

FUEL INJECTION TIMING CHART

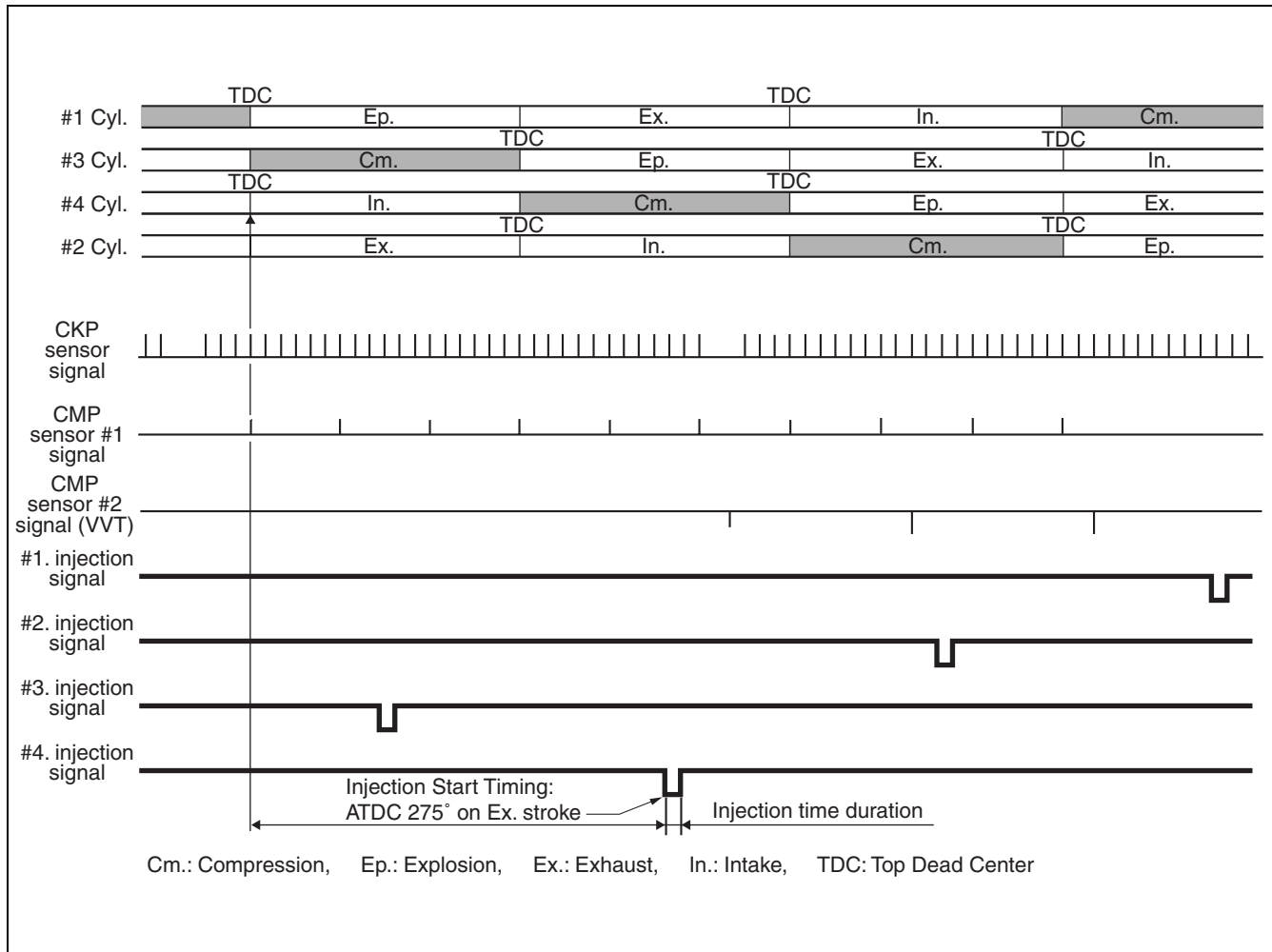

CONTROL MODE

BEFORE START:

When the ignition switch is turned “ON”, the ECM receives a MAP sensor signal, indicating the static barometric pressure of the intake manifold. This signal is used to compensate the fuel injection map for altitude.

WHEN CRANKING:

Fuel is simultaneously injected to all cylinders according to the “Start up mode” map in relation to crankshaft angle.

AFTER START (FAST-IDLE FUNCTION):

The fuel injection amount is controlled to remain increased until the timer, set according to cylinder temperature at the time of engine start, expires.

WHEN IDLING/TROLLING:

The fuel injection amount is controlled to maintain a stable engine speed at the specified idle/trolling rpm.

WHEN ACCELERATING:

The fuel injection amount is controlled to increase.

WHEN DECELERATING:

The fuel injection amount is controlled to decrease.

The fuel injection is also cut off on very rapid engine deceleration.

FUEL DELIVERY SYSTEM COMPONENTS

The fuel delivery system is composed of the low pressure fuel line components (fuel tank, filter, pump etc.), fuel vapor separator, high pressure fuel pump, high pressure fuel filter, fuel pressure regulator (located in the fuel vapor separator), delivery pipe, fuel injector and hoses.

Fuel is supplied through the primer bulb, low pressure fuel filter, and low pressure fuel pump to the fuel vapor separator.

Fuel flow from the fuel vapor separator is pressurized by the high pressure fuel pump and supplied through the high pressure fuel filter and fuel delivery pipe to the fuel injectors.

The pressure regulator maintains fuel pressure in the feed line between the high pressure fuel pump and fuel injector.

This pressure, maintained at a constant level, is higher than the pressure in the vapor separator chamber.

When fuel feed line pressure exceeds vapor separator chamber pressure by more than approx. 250 kPa (2.55 kg/cm², 36.3 psi), the valve in the fuel pressure regulator will open and return the excess fuel to the vapor separator chamber.

Pressurized fuel enters into the intake ports through the fuel injector based on the sequential signals supplied from the ECM.

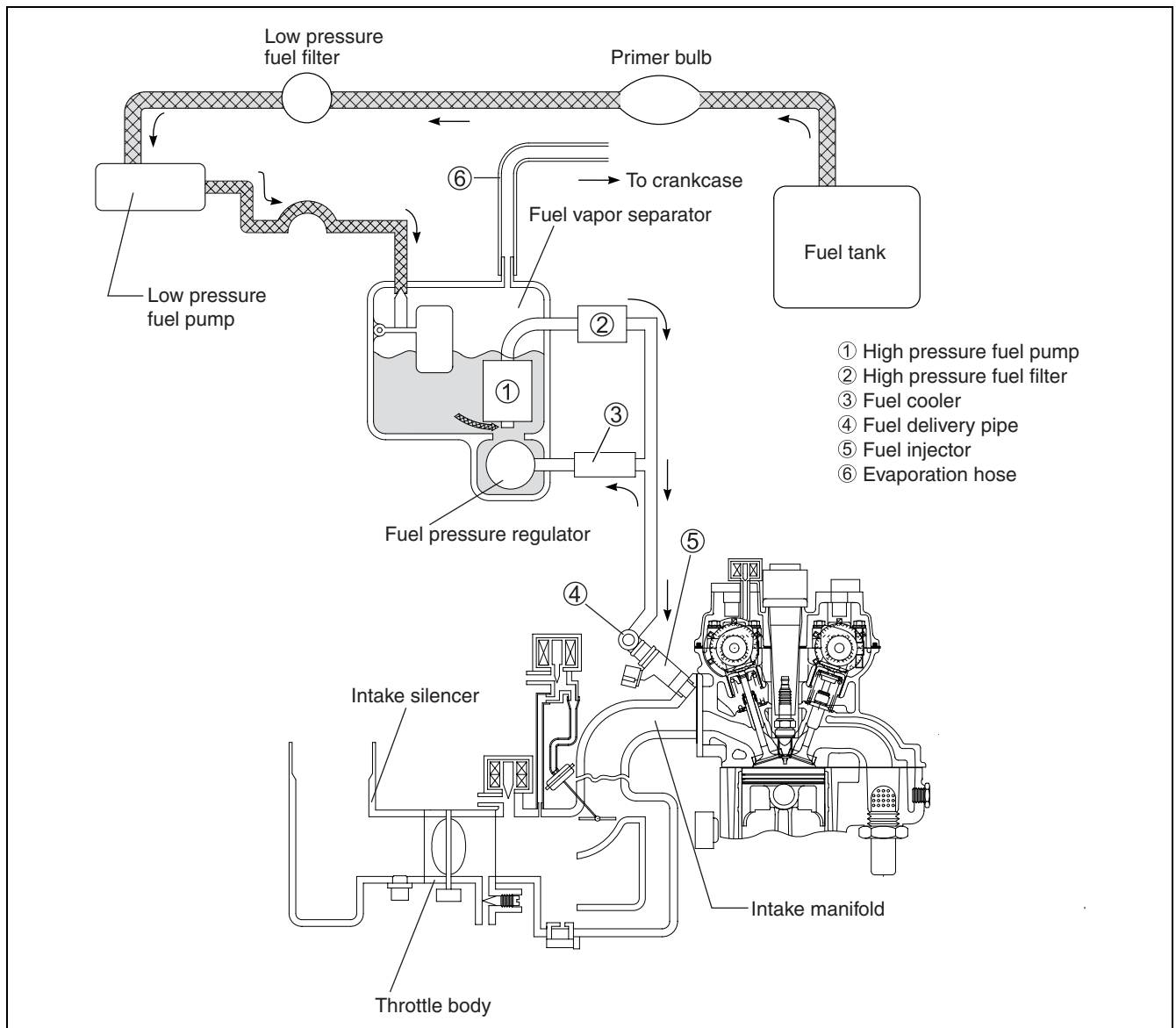

FUEL VAPOR SEPARATOR

The fuel vapor separator incorporates a float system that maintains a constant fuel level inside the separator chamber.

As the fuel level decreases, fuel flows into the vapor separator from the low pressure fuel pump.

The function of this unit is to separate vapors from fuel delivered by the low pressure fuel pump or fuel returned from the fuel pressure regulator.

This vapor is routed through the evaporation hose connecting the vapor separator cover to the crankcase.

HIGH PRESSURE FUEL PUMP

The high pressure fuel pump is an “integral” type in which the pump mechanism is located within the fuel vapor separator.

To supply the optimum fuel amount, the pump is driven by the duty cycle signal from ECM.

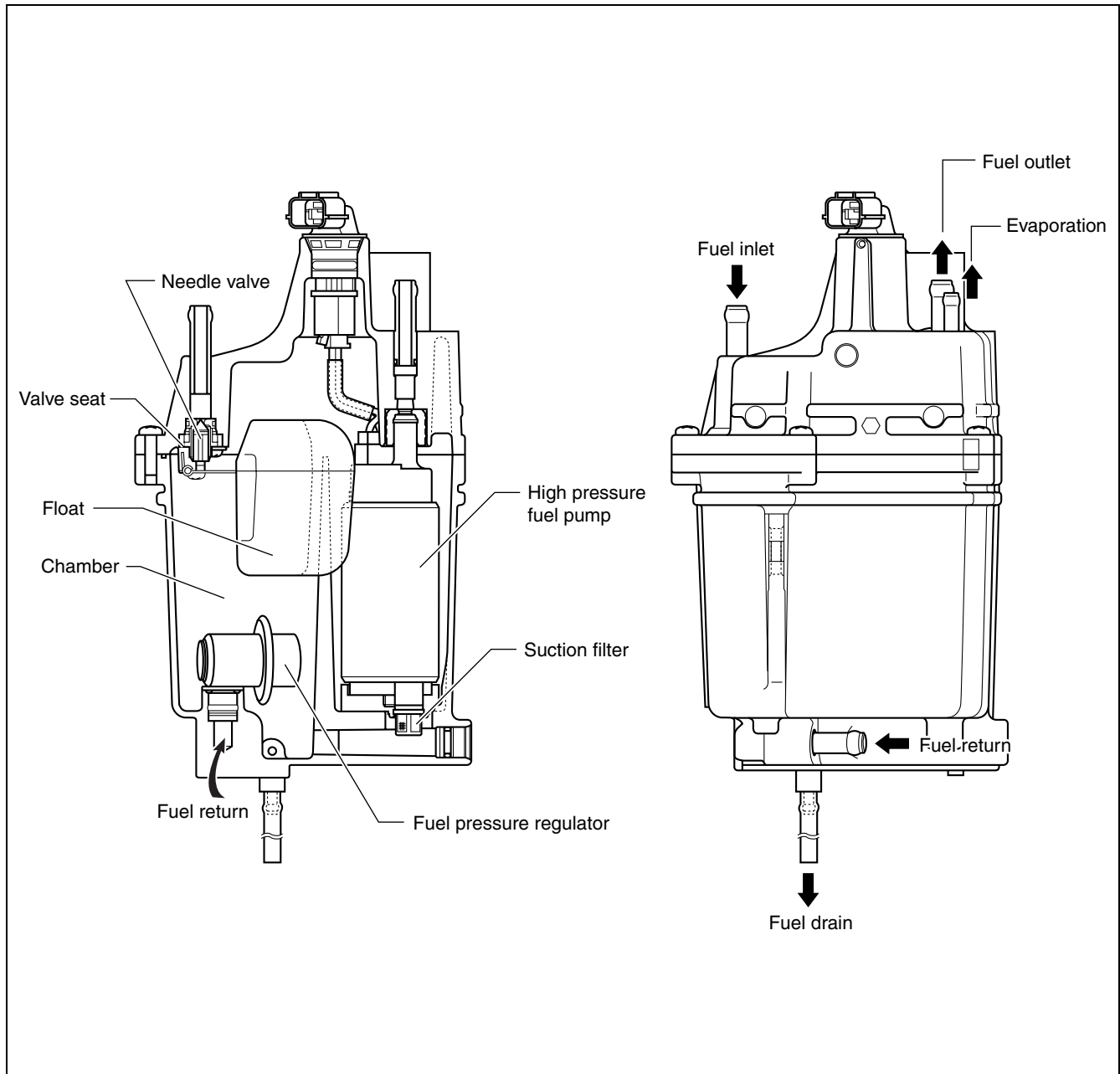

FUEL PRESSURE REGULATOR

The fuel pressure regulator is located in the fuel vapor separator.

The regulator's function in the system is to maintain a constant fuel pressure relative to the injector while the engine is operating.

The regulator diaphragm chamber is open to the fuel vapor separator chamber to keep the pressure balanced.

Fuel pressure, adjusted by the regulator, is constantly maintained higher than the pressure in the fuel vapor separator chamber by approx. 250 kPa (2.55 kg/cm², 36.3 psi).

By-pass fuel is returned to the fuel vapor separator chamber.

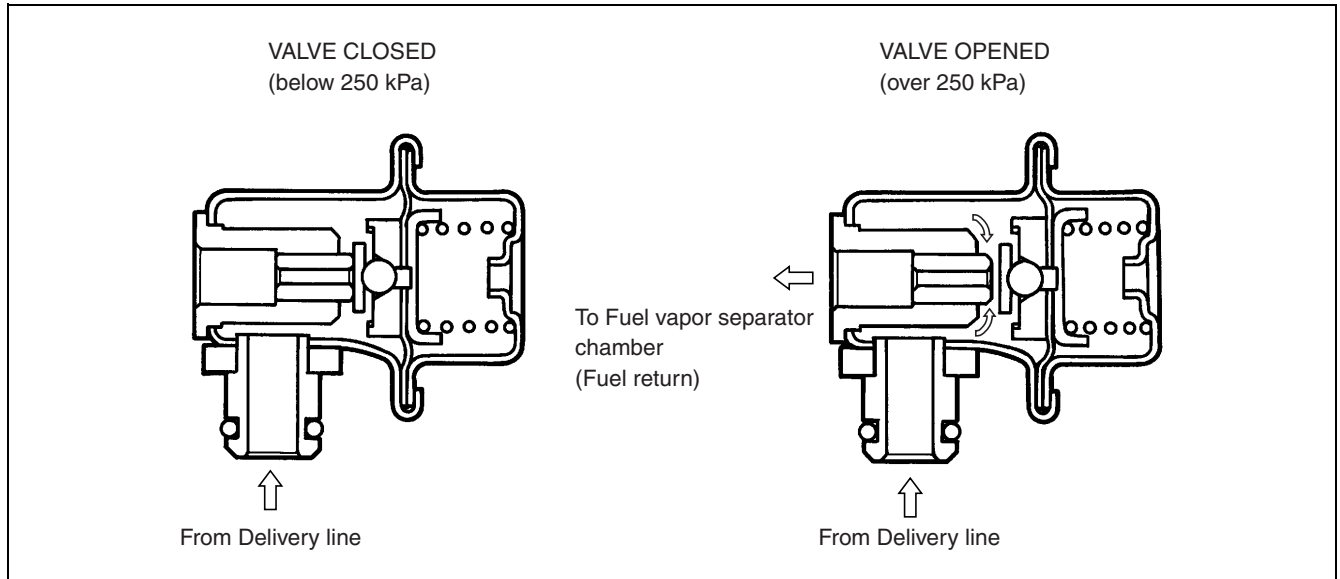

FUEL INJECTOR

The fuel injector is an electromagnetic valve operated by a signal from the ECM.

When the injection signal is supplied to the fuel injector, the solenoid coil is energized pulling up the plunger.

This opens the injector valve and injects fuel.

Because the fuel pressure is kept constant, the amount of fuel injected is determined by the amount of time (duration) the valve is open.

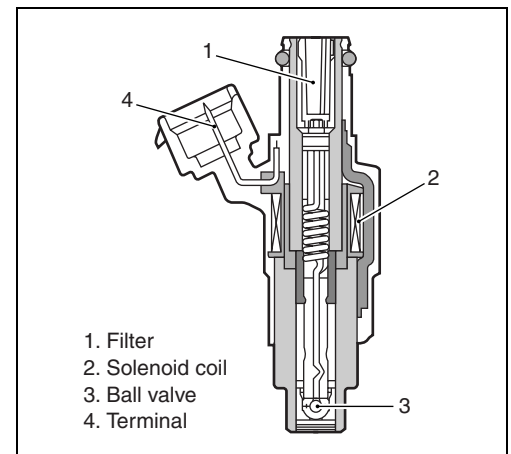

HIGH PRESSURE FUEL PUMP CONTROL SYSTEM

OUTLINE

To supply the optimum fuel amount, the ECM controls the fuel pump drive duty cycle, a repeated ON/OFF signal, at a specified rate (1 000 times a second).

Based on engine speed and battery voltage, the ECM determines the optimum duty (repeating “ON” time rate within a cycle) and sends this signal to the fuel pump.

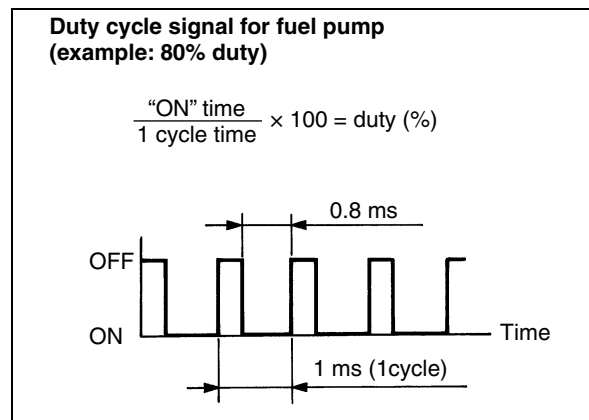
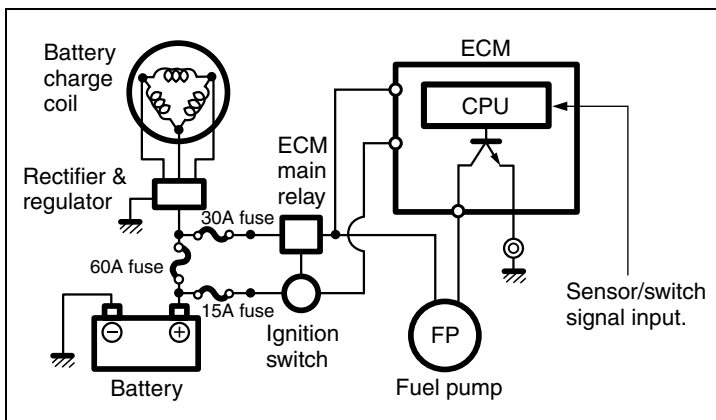
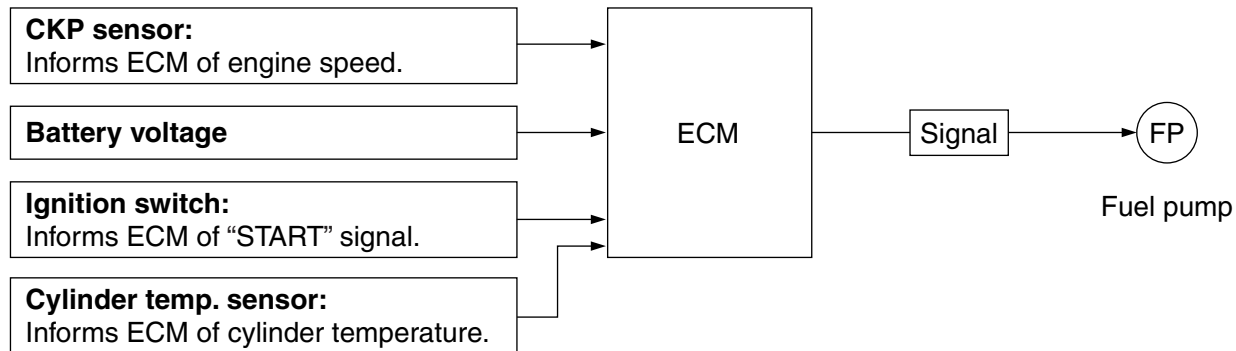

CONTROL MODES

BEFORE START:

For 6 seconds after the ignition switch is turned “ON”, the pump is controlled to operate at 100% duty in order to initially pressurize the high pressure line.

WHEN CRANKING:

The pump is controlled to operate at 50 – 100% duty.
Duty change depends on cylinder temperature.

WHEN RUNNING (NORMAL OPERATION):

The pump is controlled to operate at 50 – 100% duty based on the current engine speed and battery voltage.

AIR INTAKE COMPONENTS

Air, after entering through the silencer case, passes through the throttle body and flows into the surge tank where it is then distributed to the cylinder intake manifold.

Intake manifold pressure, monitored by the MAP sensor, is an indirect measure of the intake air amount.

When the throttle is fully closed, the main supply of intake manifold air necessary to sustain engine idle passes through the by-pass air passage.

To maintain engine idle speed at specification, the ECM controlled IAC valve supplies a regulated amount of additional air through the IAC (idle air control) passage.

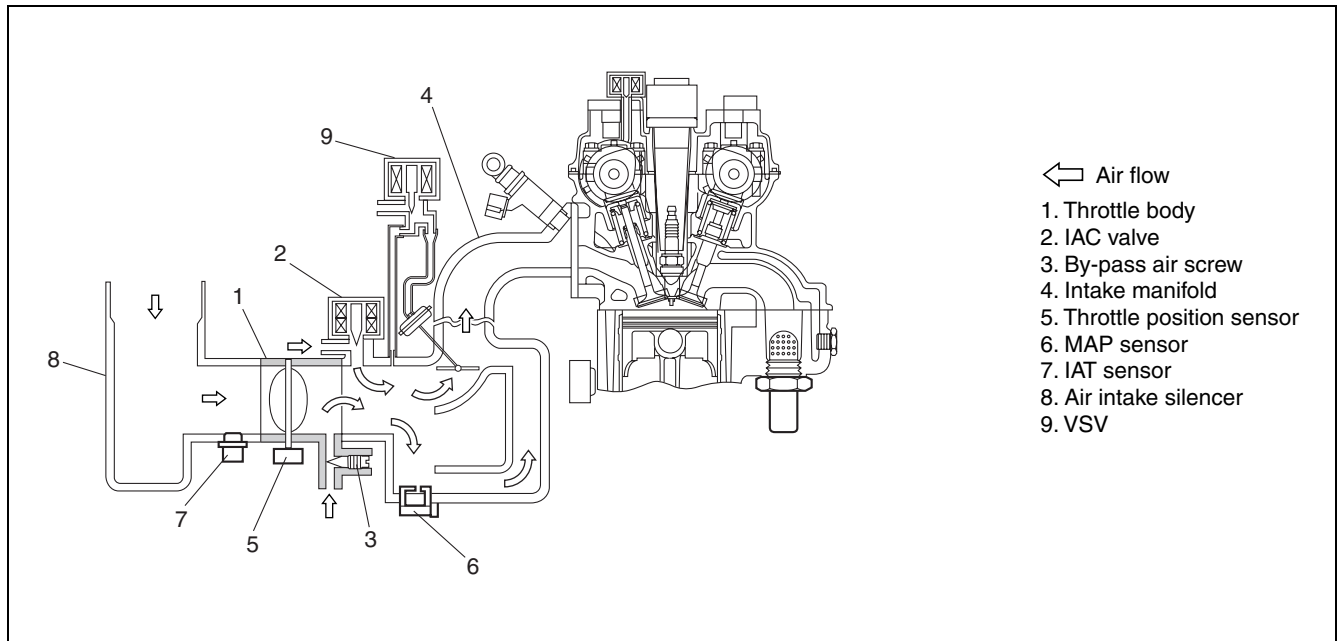

THROTTLE BODY

- The throttle body assembly consists of the main bore, throttle valve, by-pass air passage, by-pass air screw and TPS (Throttle position sensor).
- The throttle body adjusts the intake air amount with the throttle valve which is connected to the throttle lever linkage.
- The TPS installed on the throttle body informs of throttle valve opening angle.

NOTE:

Do not try to adjust or remove any of the throttle body component parts (Throttle position sensor, throttle valve, throttle stop screw, etc.).

These components have been factory adjusted to precise specifications.

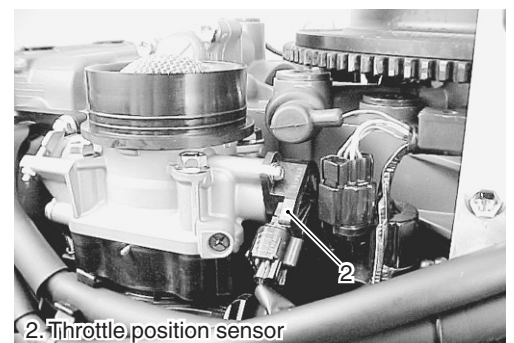

BY-PASS AIR SCREW/PASSAGE

Since the throttle valve is almost fully closed when idling/trolling, the main flow of air necessary to maintain idling/trolling speed passes through the by-pass air passage.

The by-pass air screw controls the flow of air through the passage and provides a means of partially adjusting the total amount of air necessary for idling/trolling.

NOTE:

See page 2-16 for the by-pass air screw adjustment procedure.

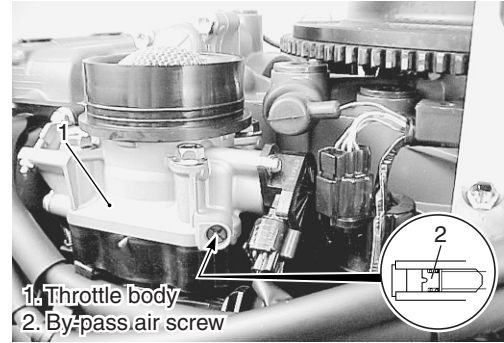

IAC VALVE/PASSAGE

The IAC valve is a stepper motor type mounted on the intake manifold.

Its purpose is to control the amount of intake air flowing from the IAC passage.

The IAC valve consists of a stepper motor, rod, valve and other parts.

As the stepper motor is controlled by signals from the ECM, valve position changes will increase or decrease the air flow through the IAC passage.



IDLE AIR CONTROL SYSTEM

OUTLINE

The ECM controls the position of the IAC valve to regulate a portion of the intake air flow to the intake manifold.

This system is used for the following purposes:

- To keep idling/trolling at specified speed.
- To improve drivability when decelerating. (Dash-pot effect)
- To improve engine starting and warm-up performance. (Fast-idle function)

The sensors/switch shown below monitor current engine condition and send signals to the ECM.

Based on these signals, the ECM determines the IAC valve opening necessary to achieve the target engine revolution and outputs the signal for actuating the stepper motor inside the IAC valve.

The rotor of the stepper motor then turns in an amount equal to the steps of the signal supplied from the ECM, moving the valve via a screw shaft.

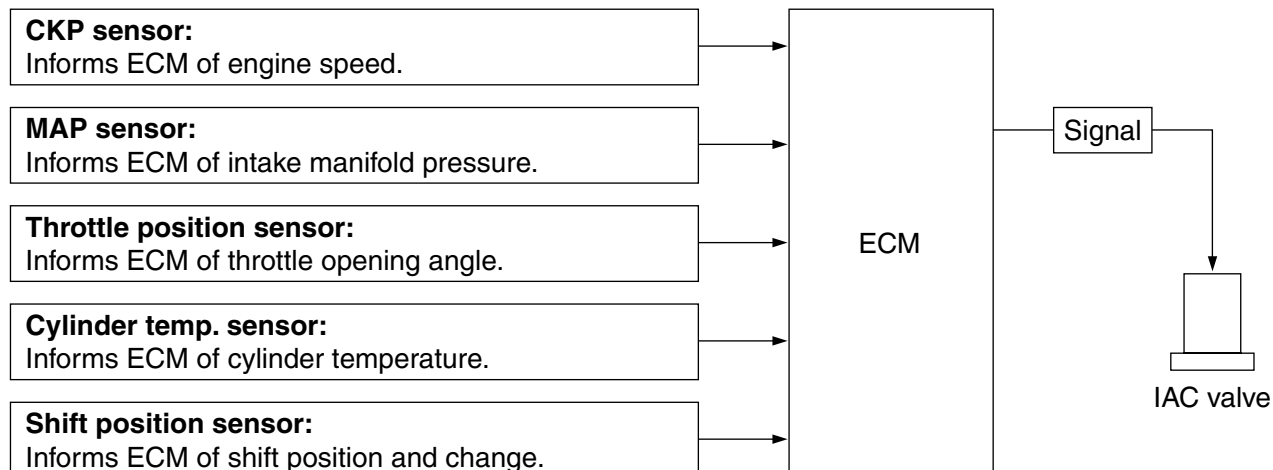

IAC VALVE

- The IAC valve uses a stepper type motor.
- The IAC valve is installed on the intake manifold.
- The IAC valve controls the volume of bypass air to stabilize the idling/trolling speed.
- The transistor driving the IAC is inside the ECM and turns ON/OFF when a signal (command) is received from the CPU.

This signal operates the stepper motor inside the IAC valve, causing it to be driven equal to the number of command signal steps. Through this procedure, the system is able to attain a very precise target idling/trolling speed.

- The stepper motor rotates by means of magnetic attraction between the stator and rotor. More specifically, shifting the stator excitation in State (1) of the illustration below to that in State (2) will develop a magnetic torque to cause the rotor to rotate and then stabilize in State (3). (The illustration below shows the operating principle of a simple stepper motor. This example differs slightly from the 2-phase excitation method used in the actual application). This operation is repeated equal to the number of command signal steps from the ECM resulting in rotation of the rotor. With the screw shaft installed, this rotation is converted to a linear motion of the valve pintle that changes the volume of IAC air flow.
- Battery voltage is applied to the center tap of each coil through the ECM main relay when the ignition switch is turned on. Each coil end connects to one of the ECM terminals “IAC 1-4”.

The terminal voltage at ECM terminals “IAC 1-4” is 1 V MAX when current flows and battery voltage at all other times.

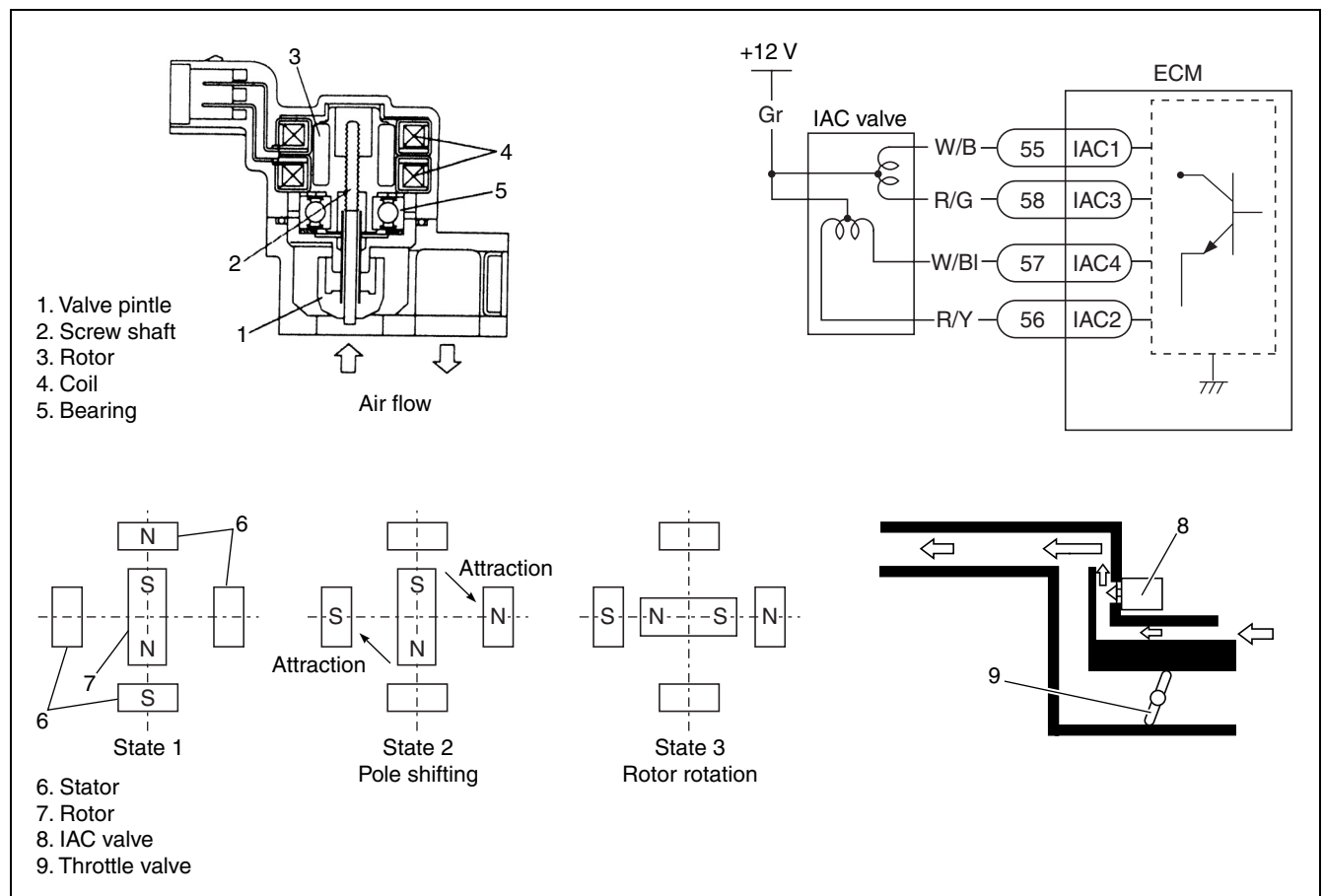

CONTROL MODE

BEFORE START:

The IAC valve is initialized at 70% opening position when engine is not running (Ignition switch OFF).

WHEN CRANKING:

The IAC valve is controlled to operate at approx. 40 – 100% duty.

Duty change depends on cylinder temperature.

AFTER START (FAST-IDLE FUNCTION):

The IAC valve is controlled to operate at approx. 10 – 70% duty until the timer, (set according to cylinder temperature at cranking) expires, then decrease duty gradually to reach the set rpm at idle.

WHEN IDLING/TROLLING:

The IAC valve is controlled so that engine speed is stable at the idling/trolling speed specified.

During this period, the IAC valve has a duty of approx. 10% but will vary slightly as idling/trolling conditions change.

WHEN RUNNING (NORMAL OPERATION):

The IAC valve is controlled to operate at 10 – 70% duty, dependent on current engine conditions.

WHEN DECELERATING (DASH-POT EFFECT):

When the throttle valve is suddenly returned to full close and the throttle position sensor signal changes to “fully closed”, the IAC valve operates at a controlled gradual return to idle/troll operating duty to prevent engine stalling or unstable running.

NOTE:

Due to the limited intake air flow from the IAC passage and in order to effectively use both the “Dash-pot effect” and “Fast-idle function”, the by-pass air screw must be adjusted to provide IAC valve operation at approx. 10 ± 5% duty at the engine idling/trolling specification. See page 2-16 for the by-pass air screw adjustment procedure.

MULTI-STAGE INDUCTION OUTLINE

The multi-stage induction system is designed to improve the intake efficiency by changing the intake tract volume in accordance with the engine speed.

This system improves low and mid range torque and increases power output at the higher rpm ranges.

SYSTEM COMPOSITION

The intake manifold assembly provides air for the low/mid range intake tract and high speed range tracts. Mounted on the intake manifold are throttle body, VSV (Vacuum Switching Valve), vacuum tank, depression chamber for operating the system and the shut off valve for switching the intake tract. System connection components include one check valve and hose to form the vacuum passage.

• VACUUM TANK

The vacuum tank stores vacuum created during engine operation. The vacuum tank's purpose is to supply a stable vacuum to the depression chamber under the varying vacuum conditions normally occurring within the intake manifold, thereby making it possible to control the shut off valve accurately.

A hose and check valve connects one side of the vacuum tank to the intake manifold. The other side of the tank is connected to the VSV with a hose.

• VSV (Vacuum Switching Valve)

One side of the VSV is connected via hose to the vacuum tank, the other side is connected via hose to the depression chamber. The VSV receives operating signals from the ECM. When the ECM signals OFF, the VSV releases vacuum to the atmosphere. When the ECM signals ON, the VSV supplies vacuum to the depression chamber.

• DEPRESSION CHAMBER

The depression chamber is designed to open/close the shut off valve.

When vacuum is applied to the depression chamber, the rod in the chamber is pulled in closing the shut off valve.

When vacuum is not applied to the chamber, the rod returns to the original position, opening the shut off valve.

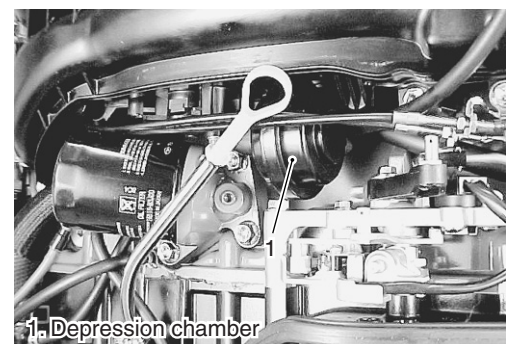
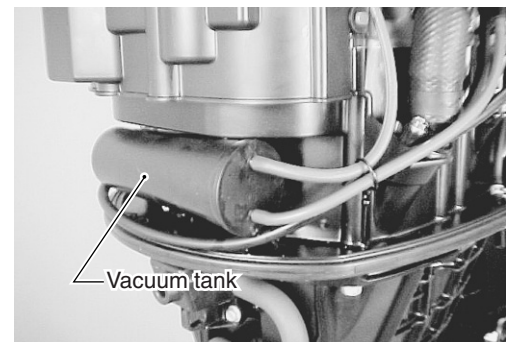
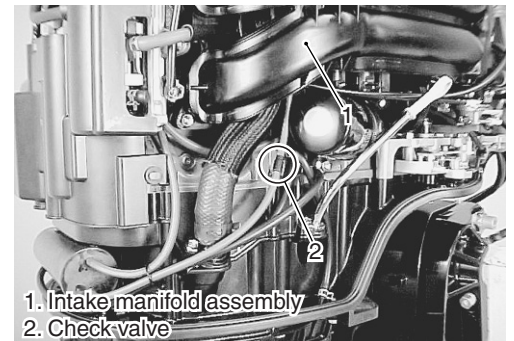

SYSTEM OPERATION

This system is operated by the vacuum created during engine operation and controlled by the ECM.

To operate the system (open/close the shut off valve to change the intake tract), the intake manifold, check valve, vacuum tank, VSV and depression chamber are connected with hoses as shown in the illustration.

A rod is used to connect the shut off valve and depression chamber for opening and closing the valve.

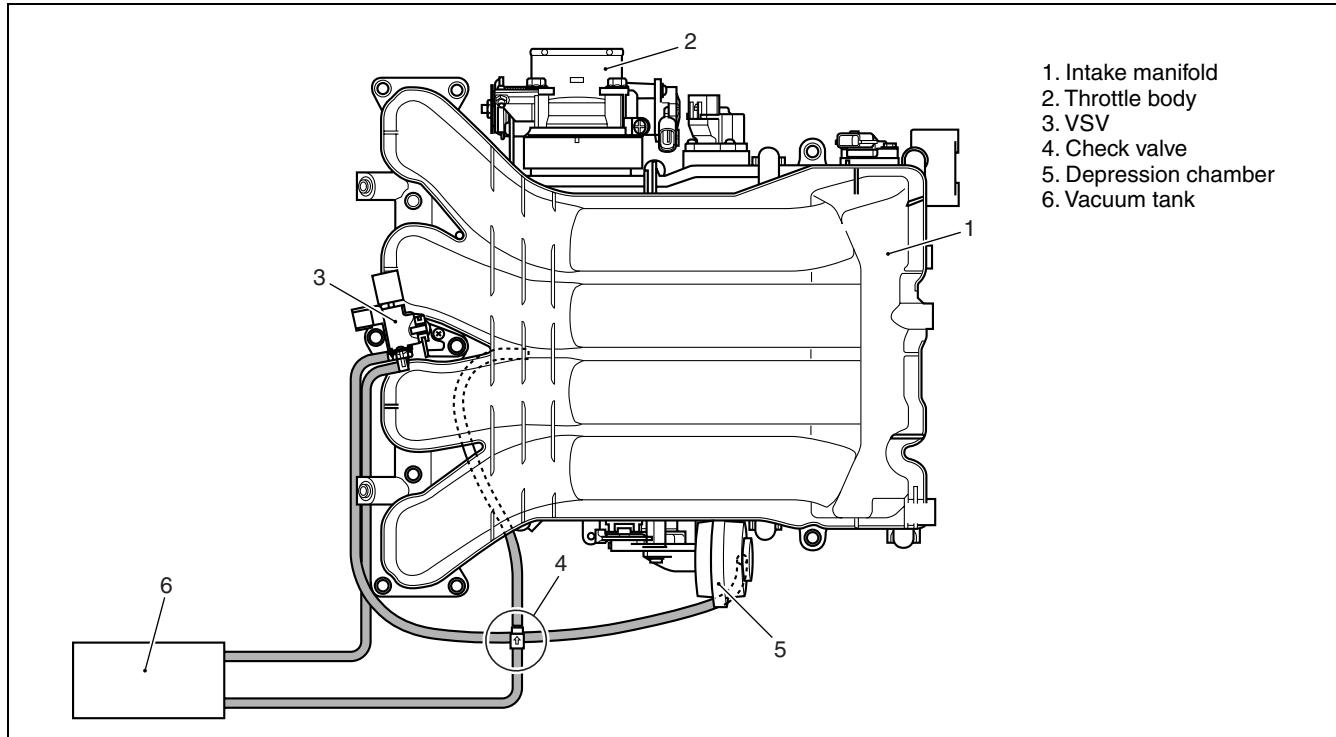

• LOW & MID SPEED RANGE

When engine speed is below the preset value (*), the ECM generates a signal to turn the VSV ON, applying vacuum to the depression chamber which closes the shut off valve.

With the valve closed during the engines low to mid speed range, intake air is supplied through the low/mid speed intake tract only.

In this operating mode, intake air speed is boosted and, combined with the inertia effect to the long intake tract, increases low and mid speed range engine torque.

*: Preset value;

DF150: approx. 4 700 r/min DF175: approx. 4 800 r/min

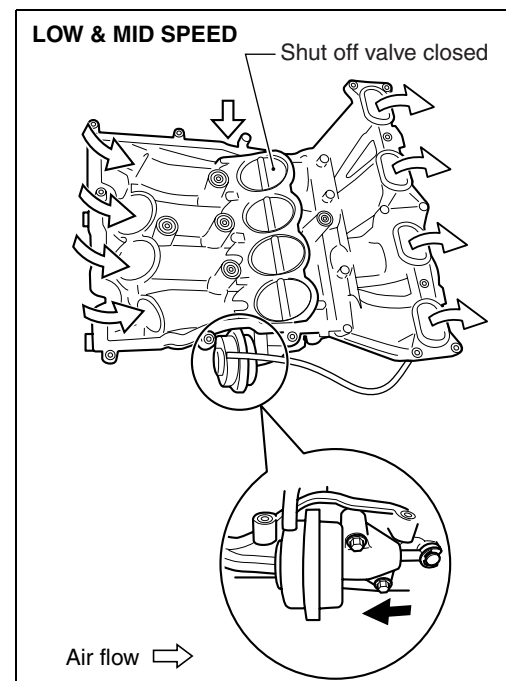

• HIGH SPEED RANGE

When the engine speed is above the preset value (*), the ECM generates a signal to turn the VSV OFF, and vacuum is no longer applied to the depression chamber.

Without vacuum the shut off valve return spring returns and holds the valve in its normal open position.

In this operating mode, intake air is supplied to the engine through the high speed intake tract only.

This enlarges the intake tract volume, improves intake inertia and efficiency, which increases the engines output power.

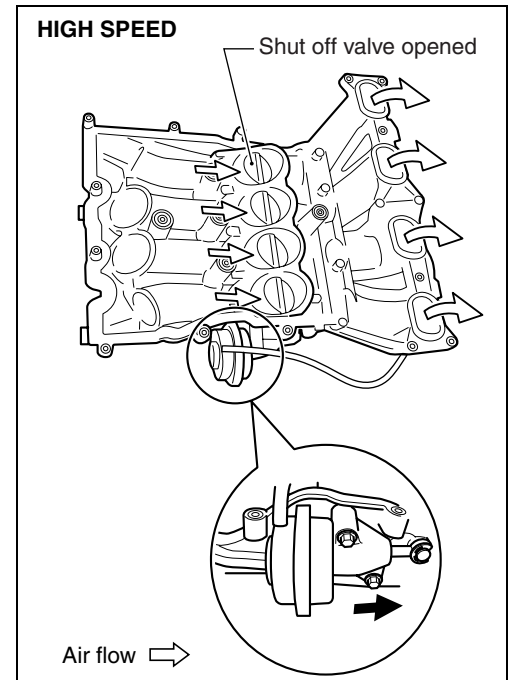

VVT (Variable Valve Timing) SYSTEM

- The VVT system is designed to continuously vary intake valve timing to best fit the engines current operating condition.
- The intake cam timing sprocket assembly (VVT actuator) is located at the front end of the intake camshaft. The timing sprocket' internal rotor is operated by engine oil pressure. Since the rotor and intake camshaft is bolted together, the rotor and camshaft move together. Varying the intake valve timing is accomplished by changing the intake camshaft phase angle relative to the intake cam timing sprocket using pressurized engine oil applied to the rotor through an ECM controlled oil control valve.
- The oil control valve (OCV) directs engine oil pressure to the advance chamber or retard chamber inside the intake cam timing sprocket assembly (VVT actuator). The oil control valve operates on a duty cycle controlled by the ECM.
- The ECM determines the optimum valve timing (advance angle) under various operating conditions based on engine speed, throttle opening and cylinder wall temperature. These input values are then used to control the position of the oil control valve (OCV). The ECM also detects the actual advance angle from the CMP sensor inputs to perform feedback control and accurately maintain the target advance angle.

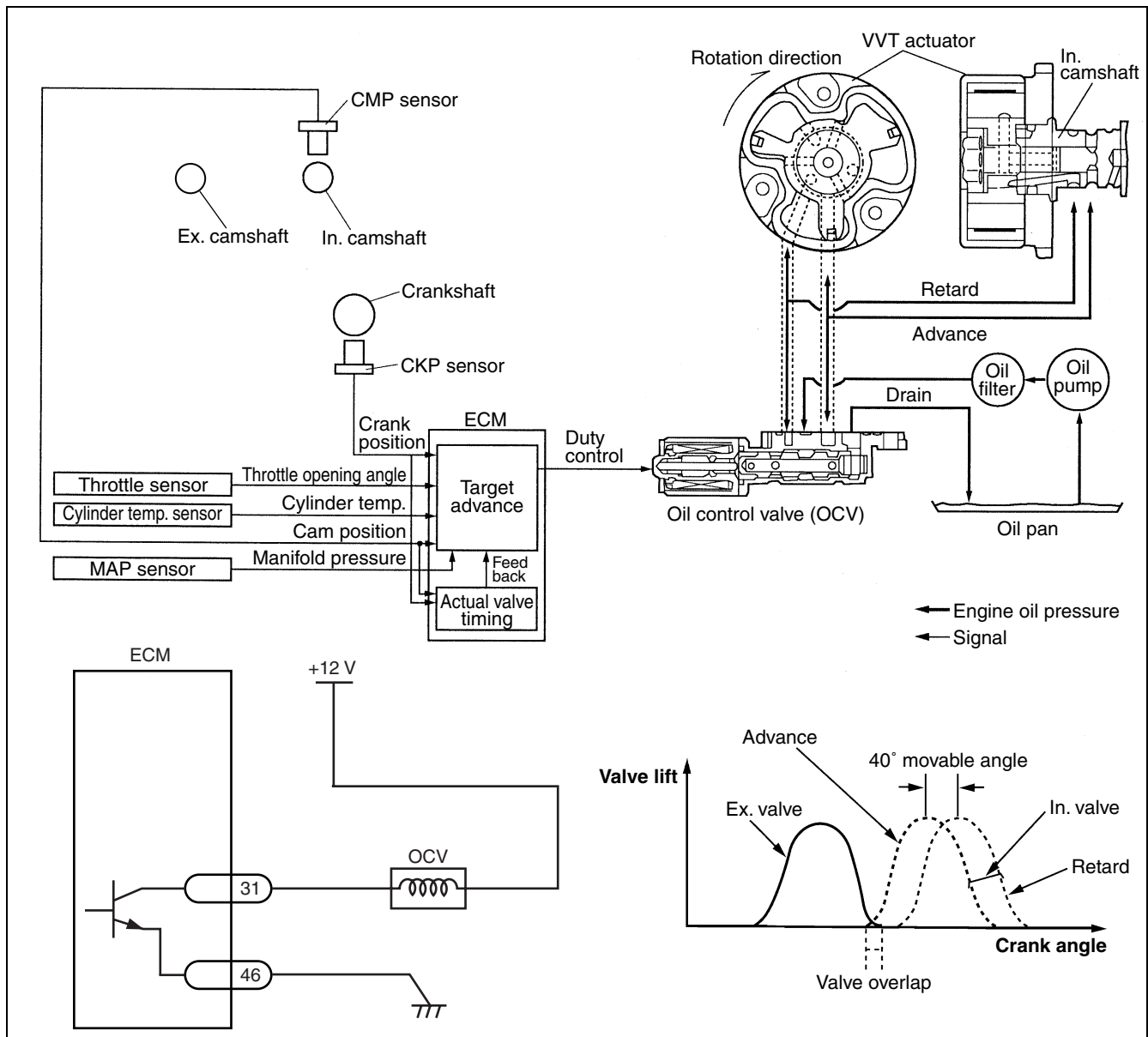

OCV (Oil Control Valve)

The OCV is used to regulate oil flow and is installed on the lower camshaft housing.

RETARD OPERATION

When the duty ratio of the ECM is small, the OCV spool valve is pushed away from the coil by spring force and engine oil pressure is applied to the retard chamber.

Engine oil remaining in the advance chamber is drained out through the spool valve.

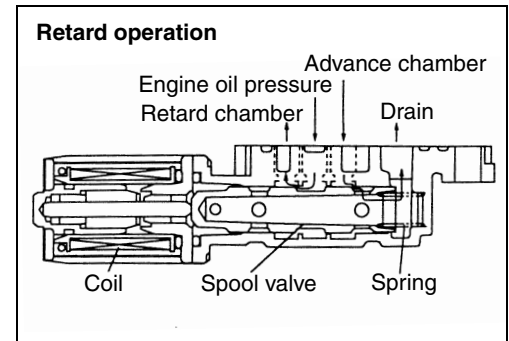

ADVANCE OPERATION

When the duty ratio of the ECM is large, the spool valve is pulled towards the coil by magnetic force, compressing the spring and applying engine oil pressure to the advance chamber side.

Engine oil remaining in the retard chamber side is drained out through the spool valve.

RETAINING OPERATION

When the duty ratio of the ECM is medium, the OCV coil's magnetic and return spring forces are equal. This positions the spool valve between the advance and retard chamber, closing both oil passages.

INTAKE CAM TIMING SPROCKET ASSY

Inside the intake cam timing sprocket assembly (VVT actuator), there are separate advance and retard chambers formed by a partition of the rotor.

The rotor moves inside the housing as engine oil pressure is applied to the advance or retard chamber.

The intake cam timing sprocket is part of the sprocket housing assembly. Since the rotor and intake camshaft are bolted together, when the rotor moves inside the housing, a change of phase angle takes place in the relative position between the intake camshaft and intake cam timing sprocket. The rotor has a spring pressured lock pin which engages with the housing when spring force is greater than oil pressure, locking the rotor in the most retarded position. This prevents a change of phase angle between the intake camshaft and intake cam timing sprocket when the engine oil pressure is low at engine start.

When the engine is started and the engine oil pressure is applied to the advance chamber, the lock pin is forced up, compressing the return spring, releasing the rotor and allowing the VVT actuator to function.

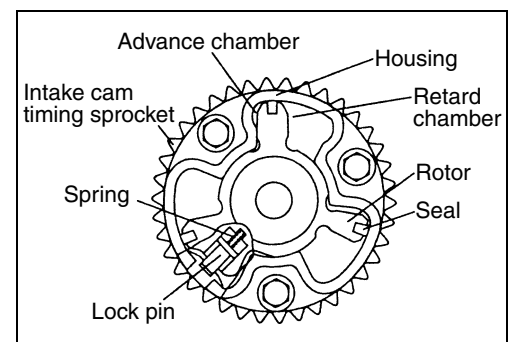

CAUTION SYSTEM

The following four caution systems alert the operator when an abnormality occurs on the engine.

- OVER-REVOLUTION CAUTION
- LOW OIL PRESSURE CAUTION
- OVERHEAT CAUTION
- LOW BATTERY VOLTAGE CAUTION

CAUTION TYPE	CAUTION LAMP	CAUTION BUZZER	OVER-REV LIMITER (3 000 r/min)
Over-revolution	Yes ①	No	Yes
Low oil pressure	Yes ② (①)	Yes	Yes
Overheat	Yes ③ (①)	Yes	Yes
Low battery voltage	Yes ④	Yes	No

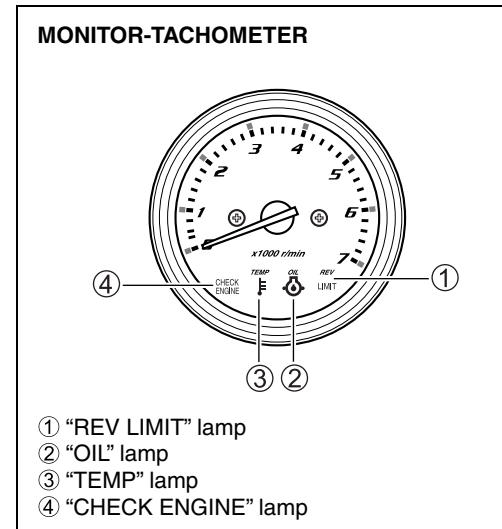

OVER-REVOLUTION CAUTION SYSTEM

CONDITION:

The ECM controlled over revolution limiter will engage at the engine speeds shown below. Once engaged it will initiate an intermittent fuel injection signal to reduce engine speed.

Over revolution limiter

DF150: 6 200 r/min

DF175: 6 300 r/min

ACTION:

Engine speed	Automatically reduced to approx. 3 000 r/min by intermittent fuel injection signal.
Caution lamp	"REV-LIMIT" lamp lights continuously.
Caution buzzer	No buzzer sounds.

RESET:

Close throttle to reduce engine speed below approx. 3 000 r/min for one second.

LOW OIL PRESSURE CAUTION SYSTEM

CONDITION:

Immediate activation of system when the oil pressure switch is turned "ON" due to an engine oil pressure drop below 100 kPa (1.0 kg/cm², 14 psi).

ACTION:

Engine speed	Automatically reduced to approx. 1 000 r/min by intermittent fuel injection signal if the system is activated at 1 000 r/min or higher.
Caution lamps	"OIL" lamp lights continuously. "REV-LIMIT" lamp lights continuously during engine speed rev-limiter activation.
Caution buzzer	Sounds in a series of long (1.5 sec) beeps.

RESET:

Stop engine and check engine oil level. Refill engine oil to the correct level if below the low oil mark.

If the engine oil level is correct, the following causes may be considered:

- Improper oil viscosity.
- Malfunctioning oil pressure switch.
- Clogged oil strainer or oil filter.
- Worn oil pump relief valve.
- Oil leakage from the oil passage.
- Excessive wear/damage of oil pump.

NOTE:

The low oil pressure caution system is reset when the oil pressure is restored to over 1.0 kg/cm² with approx. 1 000 r/min or less engine speed operation.

However, the engine must be stopped and checked immediately once the system is activated.

OVERHEAT CAUTION

CONDITION 1 (Maximum temperature)

Immediate activation of system when:

- Cylinder temperature reaches 120 °C (248 °F)
- Exhaust manifold temperature reaches 114 °C (237.2 °F)

CONDITION 2 (Temp. rise vs Time)

Immediate activation of system when:

- The average temperature difference during three consecutive 10 second measurement periods of the cylinder temperature sensor at engine speeds of 500 r/min or higher exceeds the limits as shown below.

Temperature range	Temperature difference
88 – 99 °C (190 – 210 °F)	Approx. 8 °C (46 °F)
99 °C – (210 °F –)	Approx. 1.5 °C (35 °F)

- The average temperature difference during three consecutive 10 second measurement periods of the exhaust manifold temperature sensor at engine speeds of 500 r/min or higher exceeds the limits as shown below.

Temperature range	Temperature difference
80 – 95 °C (176 – 203 °F)	Approx. 14 °C (57.2 °F)
95 °C – (203 °F –)	Approx. 1.7 °C (35 °F)

ACTION:

Engine speed	Automatically reduced to approx. 3 000 r/min by intermittent fuel injection and ignition signals if the system is activated at 3 000 r/min or higher.
Caution lamps	“TEMP” lamp lights continuously. “REV-LIMIT” lamp lights continuously during engine speed rev-limiter activation.
Caution buzzer	Sounds in a series of long (1.5 sec) beeps.

RESET:

Close throttle completely and then shift into neutral.

System reset will occur when cylinder temperature drops below the limits shown below. However, the system may be activated again unless the cause for overheat (such as insufficient water) is removed.

Caution cause	Reset temperature
Condition 1 (Maximum temperature)	Approx. 86 °C (187 °F)
Condition 2 (Temperature rise vs Time)	Approx. 84 °C (183 °F)

LOW BATTERY VOLTAGE CAUTION SYSTEM

CONDITION 1:

System activated when battery voltage decreases to less than 9 volts for 30 seconds.

CONDITION 2:

System activated if battery voltage is less than 2 V for more than 2 seconds with the ignition switch turned "ON" and engine not running.

ACTION:

Engine speed	No engine speed limiter is activated.
Caution lamp	"CHECK ENGINE" lamp lights continuously.
Caution buzzer	Sounds in a series of long (1.5 sec) beeps.

RESET:

CONDITION 1:

This caution system is automatically reset when battery voltage increases to more than 9 volts. Refrain from using electrical equipment requiring high amperage such as hydraulic trim tabs, hydraulic jack plate, etc. after this caution is activated.

CONDITION 2:

For the caution system to engage under this condition possibilities such as deteriorated battery, poor battery cable connection, battery switch in OFF condition, etc. must be inspected.

To cancel the caution system activation for these conditions, check all power source related items and eliminate the problem.

SELF-DIAGNOSTIC SYSTEM

The self-diagnostic system alerts the operator when an abnormality occurs in a signal from sensor, switch, etc.

When the system is activated, the "CHECK ENGINE" lamp flashes (lights intermittently) according to each code pattern along with a buzzer sound.

When engine is running, the buzzer sounds a series of short (0.2 sec) beeps.

When engine is not running, the buzzer sounds according to each code pattern, but not simultaneous with the lamp flash. The buzzer sound, activated by the self-diagnostic system, can be temporally canceled by pushing the ignition key in.

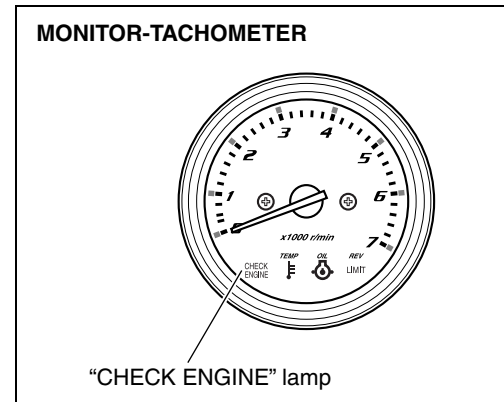

PRIORITY/CODE/PATTERN FOR SELF-DIAGNOSTIC SYSTEM OPERATION

PRIORITY	FAILED ITEM	CODE	LAMP FLASHING PATTERN	FAIL-SAFE SYSTEM ACTIVE
1	MAP sensor 1	3 - 4	ON OFF	YES
2	IAC valve/By-pass air screw adjustment	3 - 1	ON OFF	NO
3	Cylinder temp. sensor	1 - 4	ON OFF	YES
4	IAT sensor	2 - 3	ON OFF	YES
5	CKP sensor	4 - 2	ON OFF	NO
6	CMP sensor	2 - 4	ON OFF	YES
7	Air intake system	2 - 2	ON OFF	YES
8	MAP sensor 2 (Pressure detect passage)	3 - 2	ON OFF	NO
9	Exhaust manifold temp. sensor	1 - 5	ON OFF	YES
10	Fuel injector	4 - 3	ON OFF	NO
11	Throttle position sensor	2 - 1	ON OFF	YES
12	Shift position sensor	1 - 2	ON OFF	YES
13	CMP sensor (VVT)	2 - 6	ON OFF	YES
14	VVT advance	5 - 2	ON OFF	YES
15	Neutral switch	3 - 3	ON OFF	NO
16	Model discrimination/Check code wire [NOTE 2]	4 - 1	ON OFF	YES
17	Oil control valve	6 - 2	ON OFF	NO
18	Rectifier & regulator (Over-charging) [NOTE 1]	1 - 1	ON OFF	NO

NOTE:

- *If more than two items fail at once, the self-diagnostic indication appears according to priority order. The indication repeats three times.*
- *If the failed item remains, the self-diagnostic indication appears again after turning the ignition switch "ON".*
- *After correcting failed item, the self-diagnostic indication appears until the ECM receives the proper signal with the engine running.*
- *For cylinder temp. sensor, exhaust manifold temp. sensor or IAT sensor the self-diagnostic indication will be canceled after corrective action by turning the ignition switch "ON".
(The ECM will require 10 – 20 seconds after turning the ignition switch "ON" to cancel the self-diagnostic indication.)*

NOTE 1:

This self-diagnostic indication may not display (be canceled) by turning the ignition switch "ON" because the ECM detects only battery voltage, not charging output. Under this condition the buzzer will not sound a 1-1 code.

However, if the rectifier & regulator have failed, the self diagnostic indication will again appear after starting the engine.

NOTE 2:

The diagnostic code for model discrimination is displayed when a failure (either open or short circuit) exists in No.13 terminal of the wiring harness/connector.

When this code is displayed, the first check should be for a failure in the wiring harness.

When this code is displayed, do not replace the ECM.

Replacing the ECM may cause improper execution of the self-diagnostic for model discrimination possibly leading to engine trouble.

CONDITION FOR SELF-DIAGNOSTIC SYSTEM OPERATION

FAILED ITEM	CONDITION
MAP sensor 1	<ul style="list-style-type: none"> • No signal (With engine running) • Receiving an out of range “37 – 860 mmHg (1.46 – 33.86 inHg) (0.50 – 4.84 V)” signal (With engine running)
IAC valve/By-pass air screw adjustment	<ul style="list-style-type: none"> • IAC valve operates at 90% duty or higher when ECM receives fully closed position signal from throttle position sensor. [NOTE 1]
Cylinder temp. sensor	<ul style="list-style-type: none"> • No signal • Receiving an out of range “–46 to +170 °C (–114.8 – +338 °F) (0.10 – 4.6 V)” signal
IAT sensor	<ul style="list-style-type: none"> • No signal • Receiving an out of range “–46 to +169 °C (–114.8 – +336.2 °F) (0.10 – 4.6 V)” signal
CKP sensor	<ul style="list-style-type: none"> • During one crankshaft rotation, 34 signals are not input to ECM.
CMP sensor	<ul style="list-style-type: none"> • During two crankshaft rotation, 10 signals are not input to the ECM.
Air intake system	<ul style="list-style-type: none"> • During the ECM's receiving input of the complete close signal from the throttle position sensor, the engine operates at an abnormally high speed. (Criterion: 2 100 r/min MIN)
MAP sensor 2 (Pressure detect passage)	<ul style="list-style-type: none"> • Receiving unchanging signal regardless engine speed change. [NOTE 2]
Rectifier & Regulator. (Over-charging)	<ul style="list-style-type: none"> • Receiving 16 volts or higher signal
Exhaust manifold temp. sensor	<ul style="list-style-type: none"> • No signal • Receiving an out of range “–46 to +170 °C (–114.8 – +338 °F) (0.10 – 4.6 V)” signal
Fuel injector	<ul style="list-style-type: none"> • No operation signal from the ECM
Throttle position sensor	<ul style="list-style-type: none"> • No signal • Receiving an out of range “0.2 – 4.8 V” signal.
Shift position sensor	<ul style="list-style-type: none"> • No signal • Receiving an out of range “0.2 – 4.8 V” signal.
CMP sensor (VVT)	<ul style="list-style-type: none"> • During two crankshaft rotation, 4 signals are not input to ECM.
VVT advance	<ul style="list-style-type: none"> • There is a large difference between the target advance angle and the actual advance angle.
Neutral switch	<ul style="list-style-type: none"> • While the shift sensor outputs the forward or reverse signal, the ECM receives input of the neutral signal from the neutral switch.
Model discrimination	<ul style="list-style-type: none"> • There is discrepancy between the ECM memory storage and the model discrimination terminal. • [No.13 terminal open. (DF150)] • [No.13 terminal short circuit. (DF175)]
Oil control valve	<ul style="list-style-type: none"> • OCV not operating.

NOTE 1:

These conditions will be caused by IAC valve failure or incorrect by-pass air screw adjustment. If IAC valve is always closed or by-pass air is too low, the ECM controls the IAC valve duty to increase to maintain the idling/trolling speed specified.

NOTE 2:

This condition will be caused by clogged pressure detect passage in intake manifold.

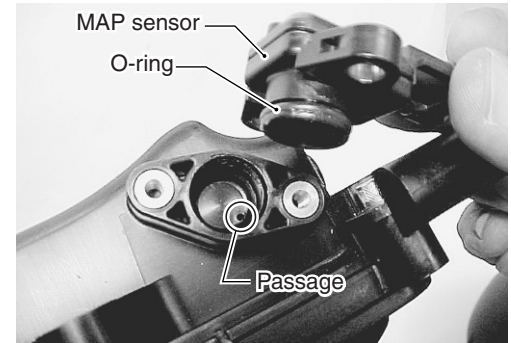

FAIL-SAFE SYSTEM

The fail-safe system is closely related to the self-diagnostic system.

When an abnormality occurs in a sensor signal, the ECM ignores the out-of-range signal and assumes a pre-programmed value for the failed sensors.

This allows the engine to continue running under the fail-safe condition.

PRE-PROGRAMMED VALUE FOR FAIL-SAFE SYSTEM

FAILED ITEM	PRE-PROGRAMMED VALUE
MAP sensor 1	<ul style="list-style-type: none"> • 260 – 760 mmHg (10.2 – 30 inHg)/(The control takes place in accordance with the engine speed.) [NOTE 1]
CMP sensor	Based on signals from CKP sensor: <ul style="list-style-type: none"> (a) Failed with engine running <ul style="list-style-type: none"> • Normal ignition timing. • Normal sequential fuel injection. • VVT advance is fixed at the most retarded angle. (b) Failed prior to engine start <ul style="list-style-type: none"> • The ignition timing fixed at BTDC 10 degree. • 1 simultaneous injection for all cylinders per 2 crankshaft rotations. • VVT advance is fixed at the most retarded angle.
Air intake system	<ul style="list-style-type: none"> • The control is executed with the maximum engine speed as 2 000 r/min.
Cylinder temp. sensor	<ul style="list-style-type: none"> • 60 °C (140 °F)
IAT sensor	<ul style="list-style-type: none"> • 45 °C (113 °F)
Exhaust manifold temp. sensor	<ul style="list-style-type: none"> • 60 °C (140 °F)
Throttle position sensor	<ul style="list-style-type: none"> • The control is executed with the throttle opening as 5 degrees.
Shift position sensor	<ul style="list-style-type: none"> • The shift position (Fwd/Neu/Rev) is detected with the neutral switch signal. • The IAC control follows the forward gear map.
CMP sensor (VVT)	<ul style="list-style-type: none"> • VVT advance is fixed at the most retarded angle.
VVT advance	<ul style="list-style-type: none"> • VVT advance is fixed at the most retarded angle. • The ECM cyclically outputs the drive and stop signals for the OCV and when the difference between the VVT's target advance angle and the actual advance angle has come to the normal range, the diagnostic code display is canceled.
Model discrimination	<ul style="list-style-type: none"> • The original model discrimination is retained.

NOTE:

There is no back-up system for the ECM itself. The engine will stop if it has failed.

NOTE 1:

This value will change according to the current engine speed.

OPERATING HOUR INDICATION SYSTEM

When the ignition switch is initially turned “ON” (from “OFF”), the ECM tests the caution system by turning on all four lamps in the monitor-tachometer and sounding the caution buzzer for an initial two seconds.

For the next three seconds, the ECM indicates the total operating hours, using a combination of the tachometer needle and “REV-LIMIT” lamp flash.

NOTE:

The total operating hours displayed are those of actual engine operation, not ignition switch “ON” time.

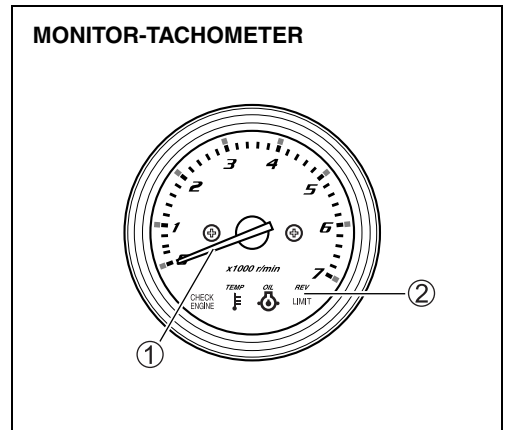

CHART OF TOTAL OPERATING HOURS INDICATION

Total operating hours	MONITOR-TACHOMETER	
	Needle ① indication	REV-LIMIT lamp ② flashing *
0 h – (49 h)	No	No
50 h	500 r/min	
60 h	600 r/min	
⋮	⋮	
540 h	5 400 r/min	
550 h	500 r/min	1 time
560 h	600 r/min	
⋮	⋮	
1 040 h	5 400 r/min	2 times
1 050 h	500 r/min	
⋮	⋮	
1 540 h	5 400 r/min	3 times
1 550 h	500 r/min	
⋮	⋮	
2 030 h	5 300 r/min	3 times
2 040 h or over	5 400 r/min	

* : One lamp flash corresponds to 500 hours.

OIL CHANGE REMINDER SYSTEM

This system informs the operator it is time to change ENGINE OIL based on the recommended maintenance schedule. When the total motor operating hours have reached the preprogrammed hours, the "OIL" lamp will flash, and the buzzer will begin a series of double beeps if engine is not running (but ignition switch is ON). The above mentioned indication will repeat until the activated system is manually cancelled.

NOTE:

This system will activate up to 2 100 hour's operation.

INDICATION OF SYSTEM ACTIVATION

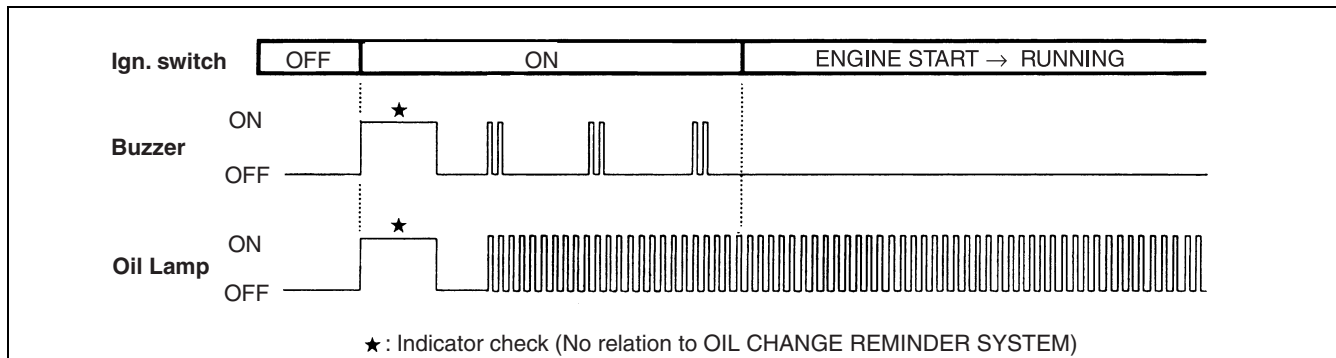
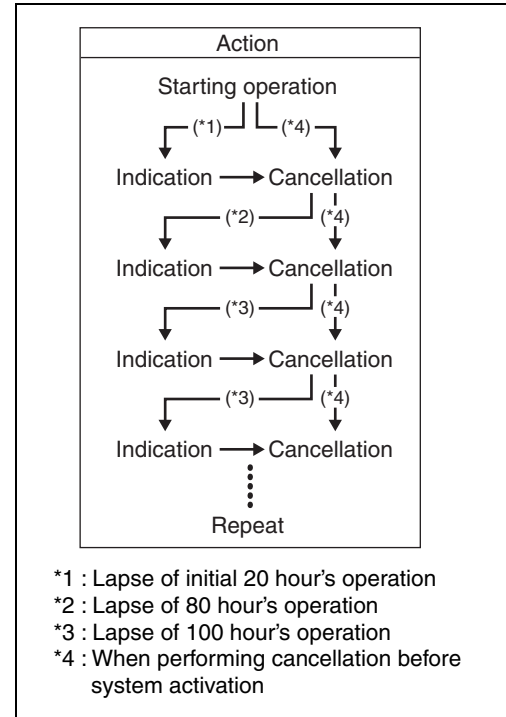
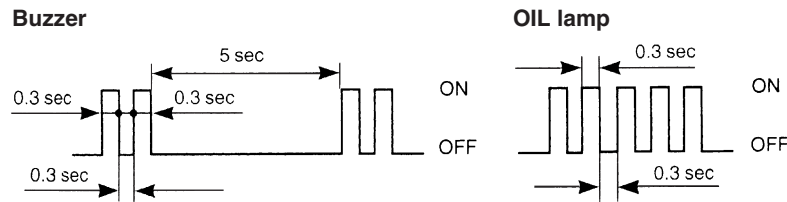

CANCELLATION

Procedure

1. Turn the ignition key to "ON" position.
2. Pull out the emergency stop switch plate ①.
3. Pull up the emergency stop switch knob ② three times in ten seconds. A short beep will be heard if cancellation is successfully finished.
4. Turn the ignition key to "OFF" position.
5. Set the switch plate ① in original position.

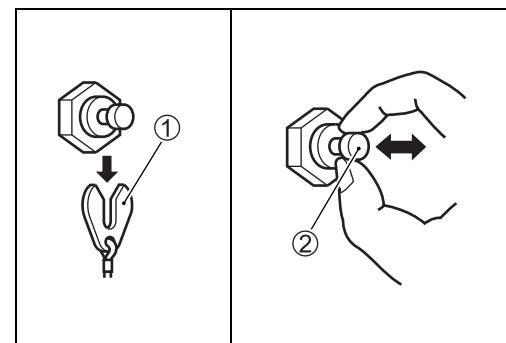

NOTE:

- *Canceling of the system activation is possible regardless of whether or not the engine oil has been replaced. Once the system has operated, however, SUZUKI strongly recommends that the engine oil be replaced before canceling the system activation.*
- *Even if the engine oil has been replaced with the system not operating, it is still necessary to perform the cancellation.*

START-IN-GEAR PROTECTION SYSTEM

■ Control by Neutral switch

A switch to detect neutral gear position is located on the throttle lever holder and operated by the clutch control lever.

This ON/OFF type switch is ON in neutral and OFF in forward or reverse.

On starting the engine, the ECM detects the shift position using the neutral switch.

When the neutral switch is OFF, the ECM does not provide starter motor relay operating signal.

■ Control by Shift position sensor

A shift position sensor is installed on the throttle lever holder and detects the shift position.

This sensor is a variable resistor that changes resistance in accordance with the shift position.

The resistance changes (increase/decrease) the voltage signal output from the sensor to the ECM. Based on the sensor voltage, the ECM calculates and detects shift position.

On starting the engine, the ECM does not provide an injector operating signal when a shift lever in-gear position is detected.

Operation by Neutral switch on engine starting

Shift position	OPERATION			
	Fuel injection	Ignition	High pressure Fuel pump	Starter motor
Neutral	YES	YES	YES	YES
Forward/Reverse	NO (*-1: YES)	NO (*-1: YES)	NO (*-1: YES)	NO

*-1: If it is in neutral judged by the ECM according to the shift position sensor signal.

Operation by Shift position sensor on engine starting

Shift position	OPERATION			
	Fuel injection	Ignition	High pressure Fuel pump	Starter motor
Neutral	YES	YES	YES	YES
Forward/Reverse	NO (*-2: YES)	NO (*-2: YES)	NO (*-2: YES)	YES

*-2: If it is in neutral judged by the ECM according to ON signal from the neutral switch.

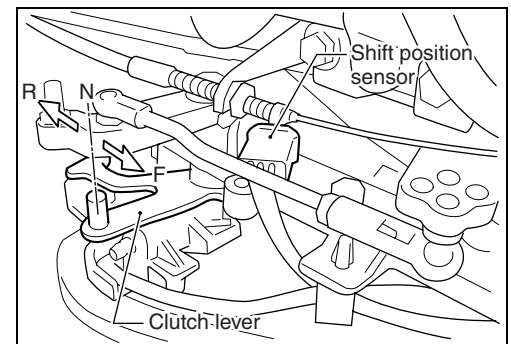
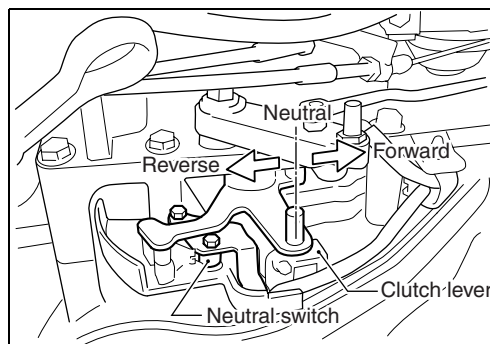

O2 FEEDBACK SYSTEM

After extended usage, the engine components may become deteriorated or worn.

This might make the A/F (air/fuel mixture ratio) incorrect which could affect exhaust emissions. To correct the A/F, an O2 sensor must be temporarily installed in the exhaust manifold. This sensor is used to measure the concentration of oxygen in the exhaust gas at engine speeds of 3 000, 4 000, and 5 000 r/min.

The ECM uses the input data from the O2 sensor to correct the compensation coefficient of the fuel injection duration map within the ECM itself.

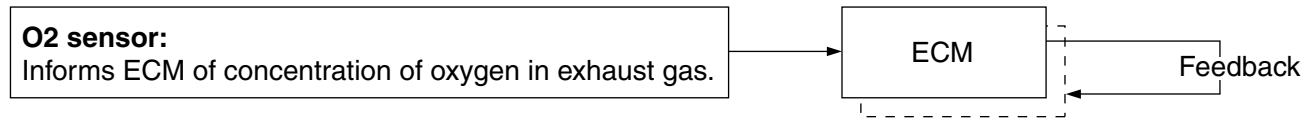

TOOL 18213-74F00: O2 sensor

NOTE:

For fuel mixture check (O2 feedback) operation procedure, refer to "Suzuki Diagnostic System Operation Manual".

INSPECTION

PRECAUTION ON SYSTEM INSPECTION

⚠ WARNING

To prevent any unexpected engine start, perform the following before proceeding with any **CRANKING** tests.

- When performing tests not related to fuel injector operation:
 - Disconnect all fuel injector wire connectors.
- When performing tests related to fuel injector operation:
 - Relieve fuel pressure in line. (See page 5-3.)
 - Disconnect high pressure fuel pump wire connector located on fuel vapor separator.

CAUTION

- Always turn ignition switch “OFF” and disconnect battery cables when wires are being disconnected or connected.
- Hold and pull connector pieces when disconnecting. Do not pull wires.

NOTE:

- The self-diagnostic codes memory in ECM will remain even if battery is disconnected.
- As each terminal voltage is affected by battery voltage, use a full-charged battery.
- Make sure all ground points have good electrical contact.
- Make sure all wires/cables are securely connected.

26-PIN & 34-PIN TEST CORD

This test cord is used when checking the circuit for voltage, etc. and connected between ECM and the wiring harness.

To measure, connect the tester probe to the relevant terminal of the test cord.

 **09930-89340: 26-pin & 34-pin test cord**

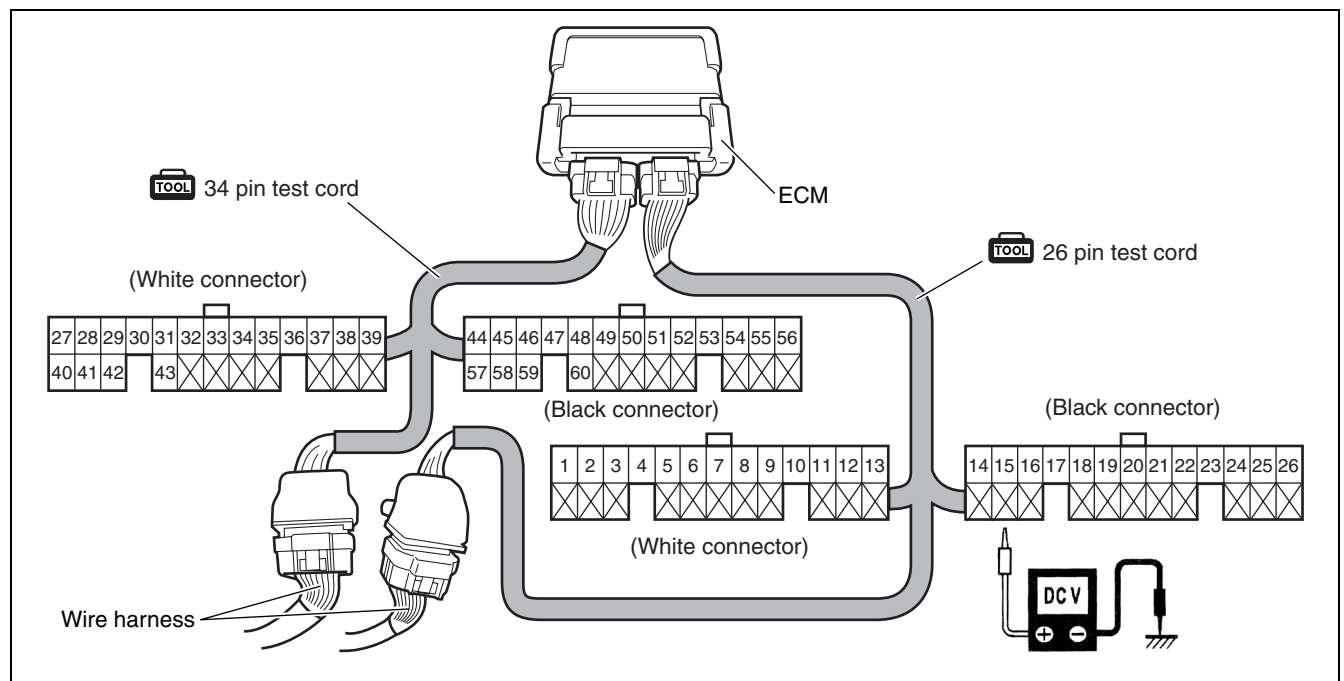

INSPECTION FOR ECM CIRCUIT VOLTAGE

CAUTION

ECM cannot be bench checked. It is strictly prohibited to connect any tester (voltmeter or ohmmeter) to an ECM which has been disconnected from the engine wiring harness.

TOOL 09930-89340: 26-pin & 34-pin test cord
 09930-99320: Digital tester

DCV Tester range: --- DCV (See chart for range.)

1. Turn ignition switch OFF.
2. Connect the 26-pin & 34-pin test cord between ECM and wire harness as shown in figure.
3. Turn ignition switch ON.
4. Connect the tester probe (⊖, Black) to body ground, and measure voltage according to the "CIRCUIT VOLTAGE TABLE".

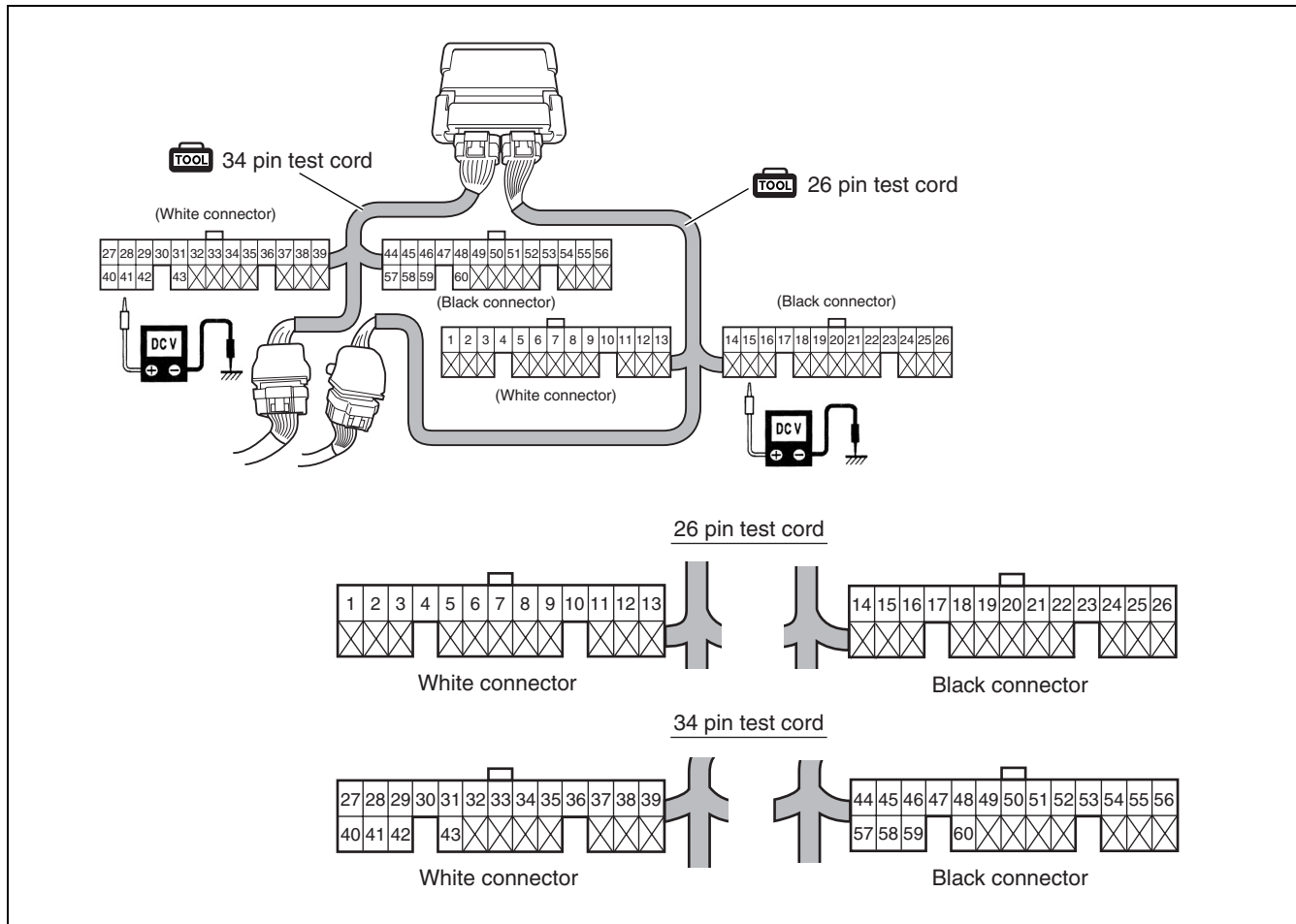

CIRCUIT VOLTAGE TABLE

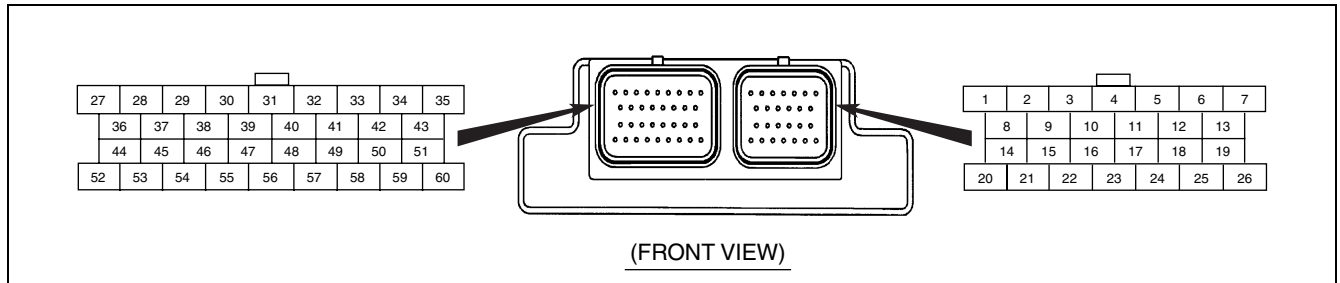

TERMINAL	WIRE COLOR	CIRCUIT	STANDARD VOLTAGE	CONDITION/REMARKS
1	G	Starter relay control	Approx. 1.3 V	Ignition switch ON, Shift in Neutral, stop switch plate OUT
			Approx. 0.5 V	Ignition switch ON, Shift in Neutral, stop switch plate IN
2	B/G	O2 Feedback	—	—
3	—	—	—	—
4	R/B	CKP sensor	—	—
5	Y/BI	CMP sensor #1	Approx. 0.3 V or 5 V	Ignition switch ON
6	—	—	—	—
7	O/G	CMP sensor #2 (VVT)	Approx. 0.3 V or 5 V	Ignition switch ON
8	V/W	Ex. manifold temp. sensor	0.14 – 4.75 V	Ignition switch ON
9	Lg/W	Cylinder temp. sensor	0.14 – 4.75 V	Ignition switch ON
10	—	—	—	—
11	P/BI	Shift position sensor	Approx. 2 V	Ignition switch ON, Shift in Neutral
			Approx. 4 V	Ignition switch ON, Shift in Forward
			Approx. 0.6 V	Ignition switch ON, Shift in Reverse
12	W	MAP sensor	0.20 – 4.53 V	Ignition switch ON
13	B (DF150 only)	Model distinction	Approx. 5 V	Ignition switch ON
14	R	Power source for sensor	Approx. 5 V	Ignition switch ON
15	BI/R	Emergency stop switch	Approx. 11 V	Ignition switch ON, Stop switch plate IN
			Approx. 0 V	Ignition switch ON, Stop switch plate OUT
16	Br/Y	Throttle position sensor	Approx. 3.8 V	Ignition switch ON, Throttle WOT
			Approx. 0.7 V	Ignition switch ON, Throttle FCT
17	P/B	Ground for ECM main relay	—	—
18	Br	Neutral/Cranking switch	Approx. 0.7 V	Ignition switch ON, Stop switch plate IN, Engine stopped, shift into NEUTRAL
			Approx. 2.5 V	Ignition switch ON, Shift into FORWARD or REVERSE
			Approx. 10 V	While engine cranking
19	BI	Oil pressure switch	Approx. 5 V	While engine running
			Approx. 0 V	Engine stopped (Ignition switch ON)
20	Gr	ECM power source	Approx. 12 V	Ignition switch ON
21	Y	PC communication	—	—
22	O/Y	PC communication	—	—
23	B/BI	Engine switch	Approx. 12 V	Ignition switch ON
24	O	Buzzer cancel	Approx. 12 V	Ignition switch ON, Key pushed in
			Approx. 0 V	Ignition switch ON, Key not pushed in
25	Lg/B	IAT sensor	0.04 – 4.46 V	Ignition switch ON

TERMINAL	WIRE COLOR	CIRCUIT	STANDARD VOLTAGE	CONDITION/REMARKS
26	—	—	—	—
27	—	—	—	—
28	R/W	No. 3 Fuel injector	Approx. 12 V	Ignition switch ON
29	—	—	—	—
30	—	—	—	—
31	Br/R	OCV	Approx. 12 V	Ignition switch ON
32	—	—	—	—
33	Gr/G	Variable intake control valve (VSV)	Approx. 12 V	Ignition switch ON
34	P/W	REV-LIMIT lamp	—	—
35	Y/B	Tachometer	—	—
36	B/Br	No. 2 Fuel injector	Approx. 12 V	Ignition switch ON
37	—	—	—	—
38	—	—	—	—
39	Gr/Y	No. 3 Ignition coil	Approx. 0 V	Ignition switch ON
40	—	—	—	—
41	—	—	—	—
42	O	No. 1 Ignition coil	Approx. 0 V	Ignition switch ON
43	Bl/W	Buzzer	—	—
44	—	—	—	—
45	Lg/R	No. 4 Ignition coil	Approx. 0 V	Ignition switch ON
46	B	Ground for power	—	—
47	B	Ground for power	—	—
48	B	Ground for ECM	—	—
49	B/W	Ground for sensors	—	—
50	Bl	No. 2 Ignition coil	Approx. 0 V	Ignition switch ON
51	Bl/B	Oil lamp	—	—
52	B/R	High pressure fuel pump (–)	Approx. 0 V	<ul style="list-style-type: none"> • Stop switch plate IN, Shift in Neutral. For 6 sec after ignition switch ON • While engine running
			Approx. 12 V	Engine stopped, Ignition switch ON, stop switch plate IN, Shift in Neutral.
53	Lg	No. 4 Fuel injector	Approx. 12 V	Ignition switch ON
54	O/B	No. 1 Fuel injector	Approx. 12 V	Ignition switch ON
55*	W/B	IAC valve #1	Approx. 12 V or 0 V	Ignition switch ON
56*	R/Y	IAC valve #2	Approx. 12 V or 0 V	Ignition switch ON
57*	W/Bl	IAC valve #4	Approx. 12 V or 0 V	Ignition switch ON
58*	R/G	IAC valve #3	Approx. 12 V or 0 V	Ignition switch ON
59	G/W	“CHECK ENGINE” lamp	—	—
60	G/Y	“TEMP” lamp	—	—

* :When 12 V is displayed at No. 55 (57) terminal, 0 (zero) V is displayed at No. 58 (56) terminal. Conversely, if 0 V is displayed at No. 55 (57) terminal, 12 V will be displayed at No. 58 (56) terminal.

INSPECTION FOR RESISTANCE

 **09930-99320: Digital tester**

 **Tester range: Ω (Resistance, See chart for range.)**

NOTE:

Make sure ignition switch is always OFF when measuring resistance.

1. Turn ignition switch OFF.
2. Disconnect battery cables from battery.
3. Disconnect wire harness connector from ECM.
4. Connect the tester probes to terminal (wire harness side) and measure resistance according to the "RESISTANCE TABLE".

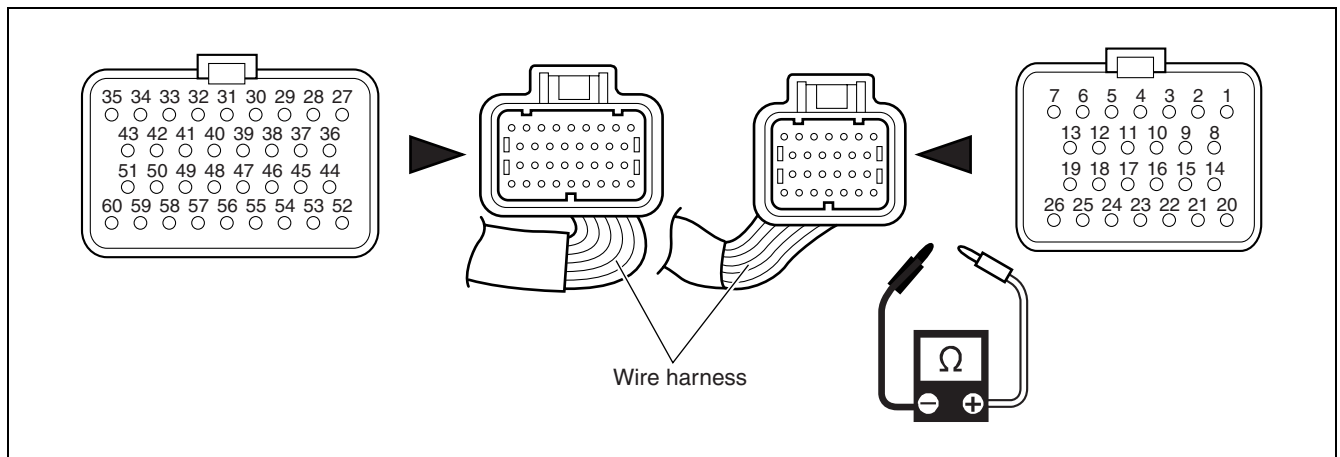

NOTE 1:

Disconnect ECM main relay from fuse box, and connect tester probe to relay terminal "A" of fuse box side.

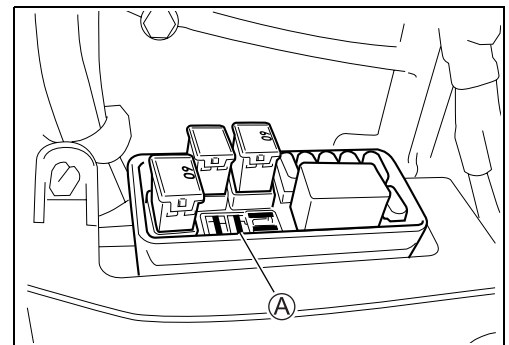

NOTE 2:

Disconnect remote control wire harness and connect tester probe to terminal ("B", White wire).

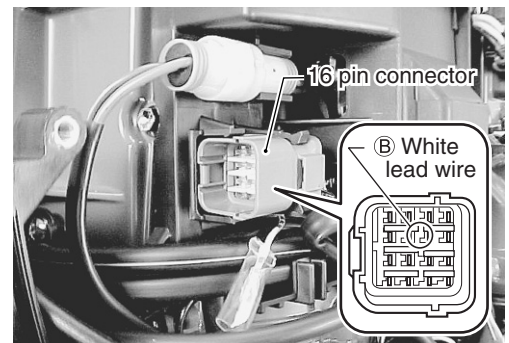

NOTE 3:

Disconnect 10 amp. (IAC, CMP) fuse from fuse box and connect tester probe to fuse terminal "C" of fuse box side.

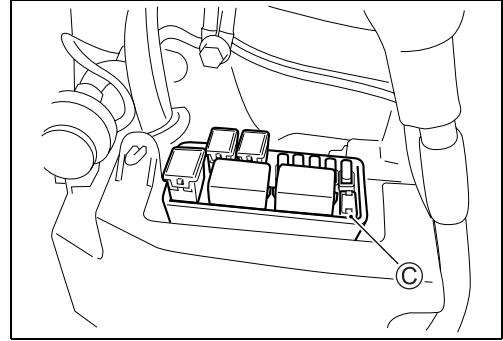
**RESISTANCE TABLE**

ITEM	TERMINAL FOR TESTER PROBE CONNECTION	STANDARD RESISTANCE (at 20 °C)
CKP sensor	4 (R/B) to 49 (B/W)	168 – 252 Ω
Fuel injector No. 1	54 (O/B) to Terminal A [NOTE 1]	10 – 14 Ω
Fuel injector No. 2	36 (B/Br) to Terminal A [NOTE 1]	
Fuel injector No. 3	28 (R/W) to Terminal A [NOTE 1]	
Fuel injector No. 4	53 (Lg) to Terminal A [NOTE 1]	
IAC valve #1	55 (W/B) to Terminal C [NOTE 3]	25 – 34 Ω
IAC valve #2	56 (R/Y) to Terminal C [NOTE 3]	
IAC valve #3	58 (R/G) to Terminal C [NOTE 3]	
IAC valve #4	57 (W/Bl) to Terminal C [NOTE 3]	
OCV (Oil control valve)	31 (Br/R) to Terminal C [NOTE 3]	6.0 – 8.3 Ω
VSV (Vacuum switching valve)	33 (Gr/G) to Terminal C [NOTE 3]	34 – 46 Ω
IAT sensor	25 (Lg/B) to 49 (B/W)	0 °C (32 °F): 5.3 – 6.6 kΩ
Cylinder temperature sensor	9 (Lg/W) to 49 (B/W)	25 °C (77 °F): 1.8 – 2.3 kΩ
Ex-manifold temperature sensor	8 (V/W) to 49 (B/W)	50 °C (122 °F): 0.73 – 0.96 kΩ
		75 °C (135 °F): 0.33 – 0.45 kΩ (Thermistor characteristic)
ECM main relay	17 (P/B) to Terminal B [NOTE 2]	145 – 190 Ω

COMPONENT INSPECTIONS

HIGH PRESSURE FUEL PUMP 6 SEC OPERATING SOUND

1. Install the emergency stop switch lock plate in position.
2. Shift into Neutral.
3. Turn ignition switch ON and check for fuel pump operating sound.

Fuel pump operating sound:

Sounds for approx. 6 seconds only

NOTE:

Fuel pump operating sound is low because pump is inside fuel vapor separator. If you cannot hear pump sound clearly, use a sound scope or long blade screw driver.

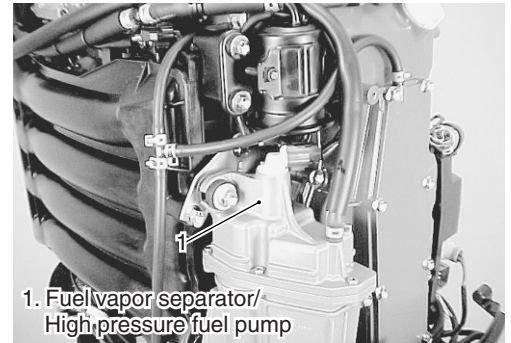

FUEL INJECTOR OPERATING SOUND (CRANKING)

1. Disconnect all ignition coil connectors.
2. Touch a sound scope or long blade screw driver to fuel injector body as shown.
3. Crank engine and check for injector operating sound.

Injector operating sound: "Click"

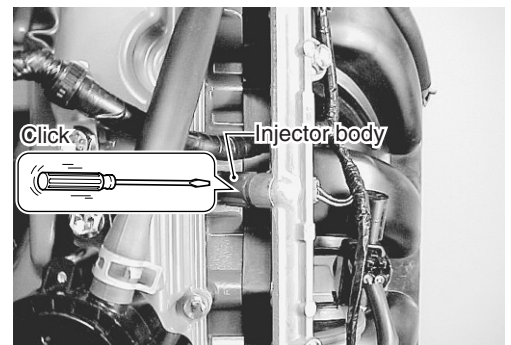

FUEL INJECTOR OPERATING SOUND (INDIVIDUAL)

1. Disconnect fuel injector wire and connect test cord.

TOOL 09930-89260: Injector test cord A

2. Connect Gray wire to body ground.
3. Momentarily touch Black/Yellow wire to starter motor magnetic switch "B" terminal (connected to battery positive ⊕ terminal) and check for injector operating sound.

Injector operating sound: "Click"

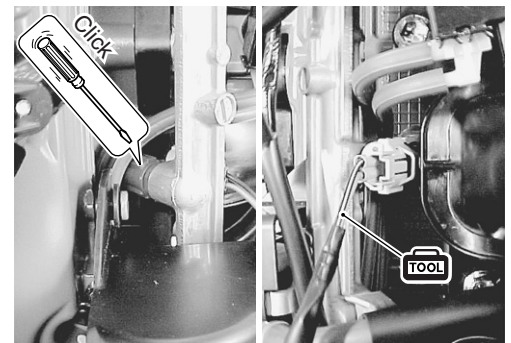

CAUTION

Connecting fuel injector to battery positive for more than a few seconds may cause injector overheating and possible injector solenoid failure.

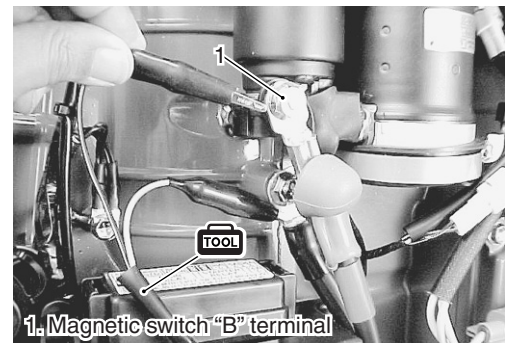

FUEL INJECTOR OPERATING SIGNAL

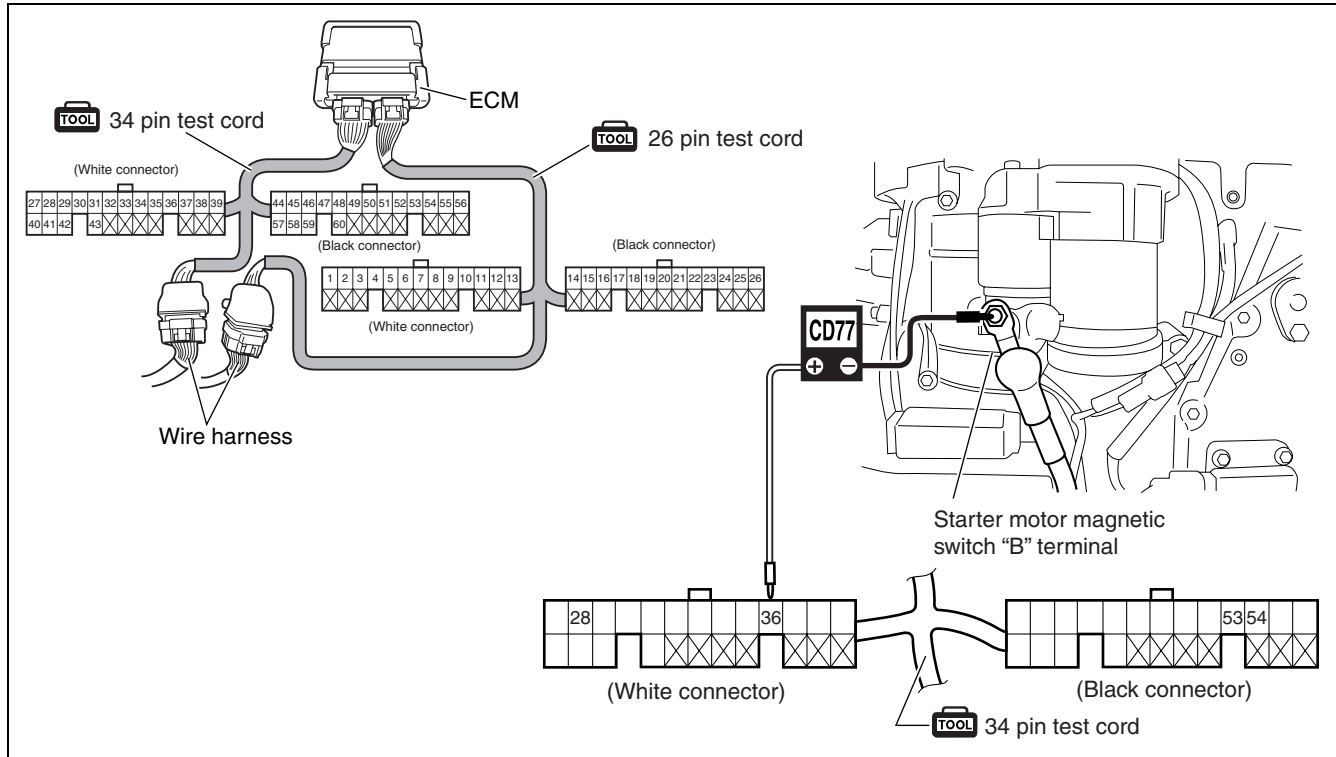

TOOL 09930-89340: 26-pin & 34-pin test cord

Peak voltmeter Stevens CD-77

Tester range: NEG 50

1. Disconnect all ignition coil connectors.
2. Connect test cord between ECM and wire harness as shown in figure then turn ignition switch ON.
3. Connect the tester probe (⊖, Black) to starter motor magnetic switch "B" terminal (connected to battery positive ⊕ terminal) as shown in figure.
4. Connect the tester probe (⊕, Red) to each terminal.

Injector	Terminal	Wire color (engine harness)
No. 1	54	O/B
No. 2	36	B/Br
No. 3	28	R/W
No. 4	53	Lg

5. Crank engine and measure voltage.

Fuel injector operating signal: 6 – 10 V

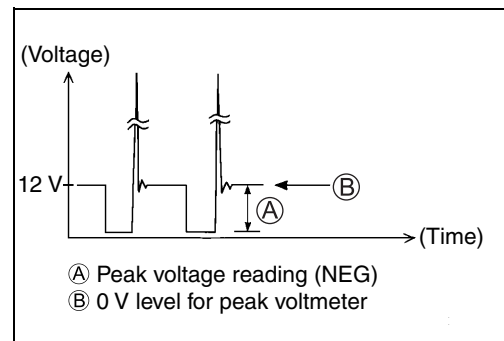

IGNITION COIL OPERATING SIGNAL

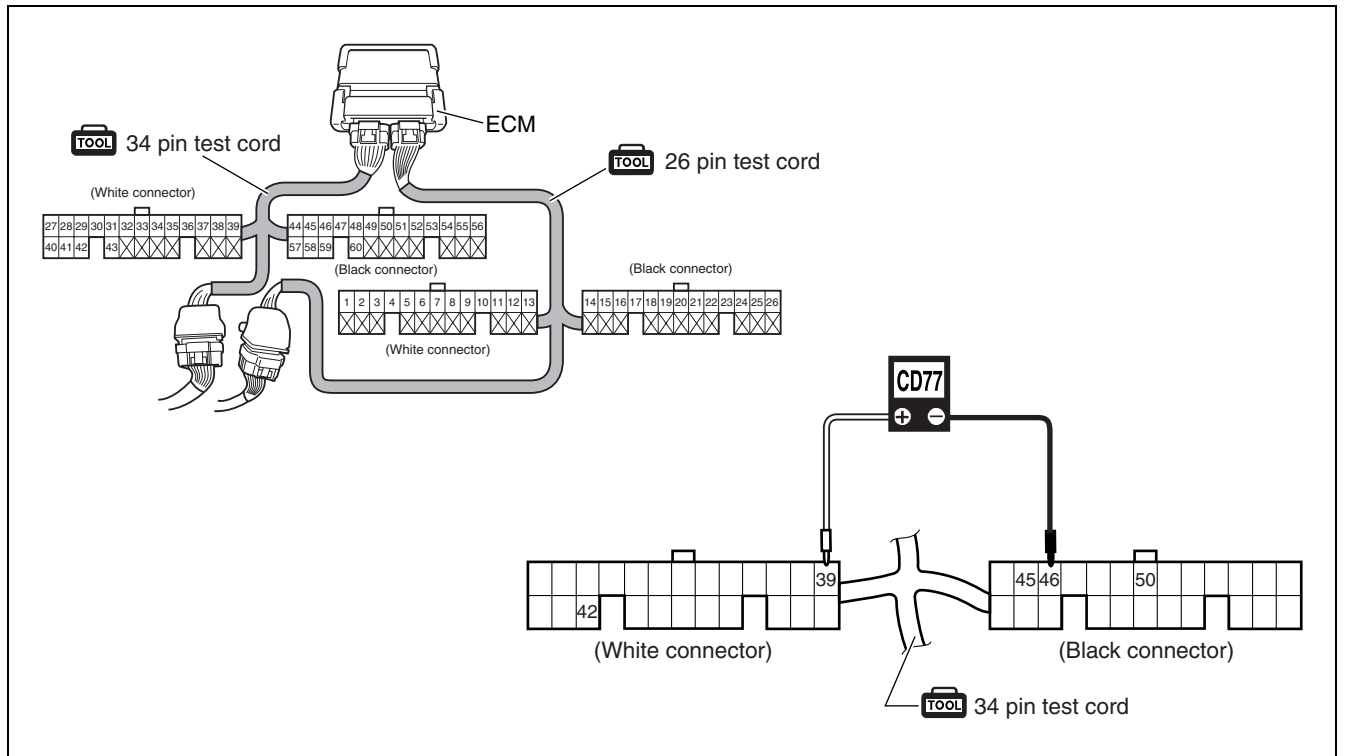
TOOL 09930-89340: 26-pin & 34-pin test cord
Peak voltmeter Stevens CD-77
CD77 Tester range: SEN 50

1. Connect test cord between ECM and wire harness as shown in figure then turn ignition switch ON.
2. Connect the tester probe (“⊕”, Red) to each terminal.

Ignition coil	Terminal	Wire color (engine harness)
No. 1	42	O
No. 2	50	Bl
No. 3	39	Gr/Y
No. 4	45	Lg/R

3. Connect the tester probe (“⊖” Black) to No. 46 terminal (or to body ground).
4. Crank engine and measure voltage.

Ignition coil operating signal: Approx. 5 V

IGNITION COIL ASSEMBLY

TOOL 09930-99320: Digital tester

DCV Tester range: --- DCV (See chart for range.)

NOTE:

The ignition coil power transistor and high-tension lead are an integral part of the coil's internal circuit. Using resistance measurements to check for a defect on either the primary or secondary coil is not possible.

1. Turn ignition key OFF.
2. Disconnect ignition coil connector.
3. Check for continuity between GND ⊖ terminal on the wiring harness side connector and the engine body ground.
4. Turn the ignition key to ON position. Check for battery voltage by measuring between the BAT ⊕ terminal and GND terminal on the wiring harness side connector.
5. Connect the wiring harness connector to the ignition coil and measure the ignition operating signal. (See page 3-55.)
6. If any failure exists, check for open circuit, short-circuited battery, short-circuited lead and connector's contact condition for each circuit.
7. If there is no spark even with the wiring harness and spark plug in sound condition, perform inspection again using an ignition coil that is known to be in good condition (new or used from another cylinder that is operating properly).
8. If there is still no spark even with the wiring harness, spark plug and ignition coil in sound condition, replace the ECM and perform inspection again.

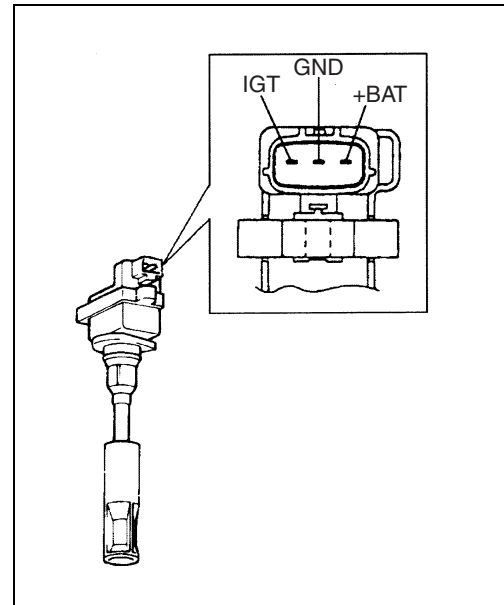

CMP SENSOR SIGNAL

TOOL 09930-89340: 26-pin & 34-pin test cord
 09930-99320: Digital tester

DCV Tester range: --- DCV (See chart for range.)

1. Turn ignition switch OFF.
2. Remove CMP sensor. (See page 3-69.)
3. Connect the 26-pin & 34-pin test cord between ECM and wire harness as shown in figure.
4. Connect the tester probe (“+”, Red) to each terminal.

CMP sensor	Terminal	Wire color (engine harness)
No. 1	5	Y/BI
No. 2 (VVT)	7	O/G

5. Connect the tester probe (“-”, Black) to No. 49 terminal (or to body ground).
6. Turn ignition switch ON.
7. Measure the voltage when the tip of a steel screwdriver is brought near and then pulled away from the sensor tip.

When screwdriver is brought near: Approx. 5 V



When screwdriver is pulled away: Approx. 0.3 V

If the voltage does not change in the above test, check wire harnesses for open and short.

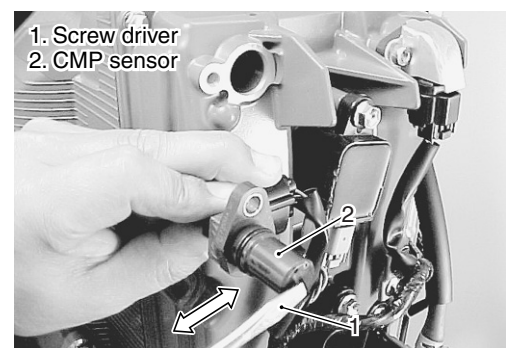
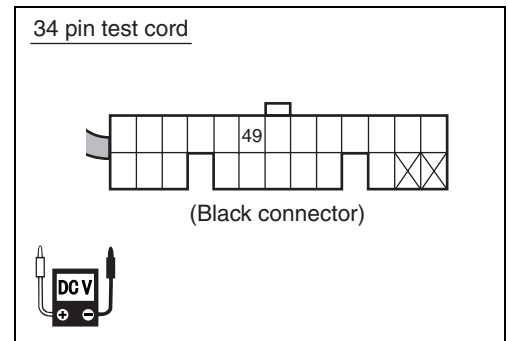
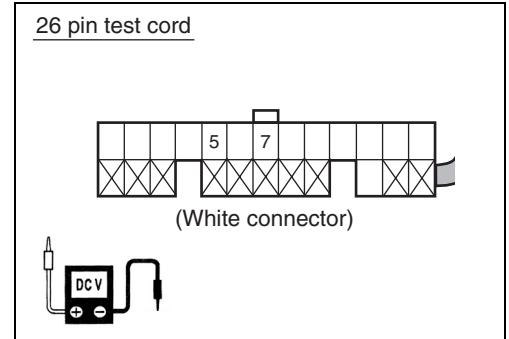
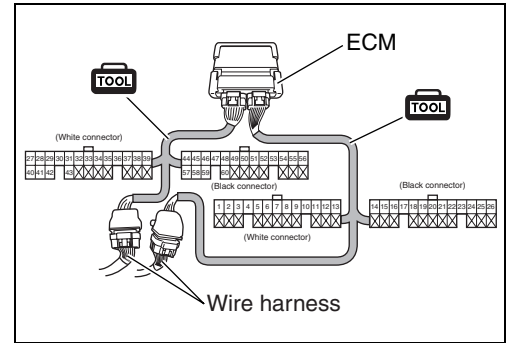
If wire harnesses are in good condition, replace CMP sensor and recheck.



MAP SENSOR OUTPUT VOLTAGE CHANGE

-  **09917-47011: Vacuum pump gauge**
- 09930-89340: 26-pin & 34-pin test cord**
- 09930-99320: Digital tester**
-  **Tester range: --- DCV (See chart for range.)**

1. Remove flywheel. (See page 3-66.)
2. Remove the three bolts and fuel hose guard.
3. Remove bolts and MAP sensor from intake manifold.

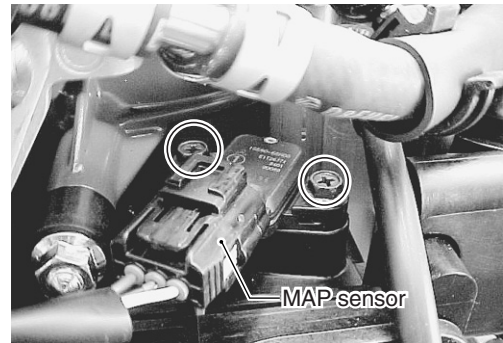
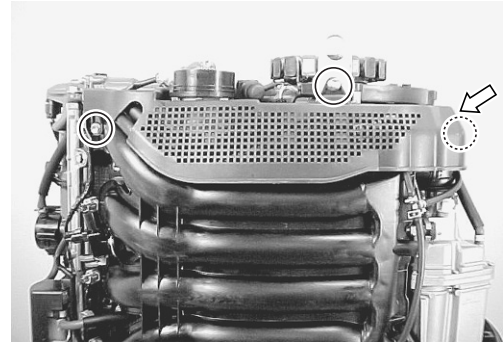

4. Install MAP sensor into special tool.

-  **09917-49610: Vacuum pump adaptor**

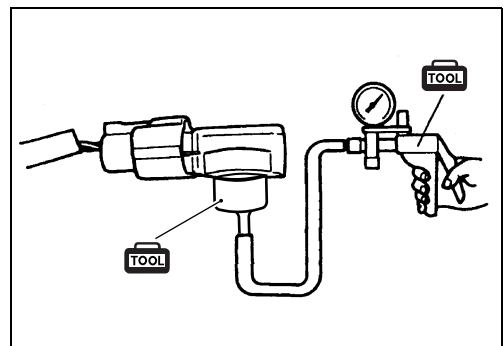

5. Connect vacuum pump gauge (with hose) to MAP sensor (special tool) as shown in figure.
6. Turn ignition switch ON.
7. While applying negative pressure (vacuum) to MAP sensor, measure "12" terminal voltage. (See page 3-48 and 3-49 for procedure.)

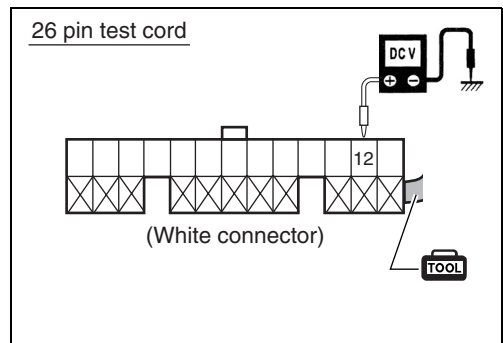

MAP sensor output voltage change:

Negative pressure kPa (kg/cm², mmHg)	0 (0, 0)	40 (0.4, 300)	80 (0.8, 600)
"12" terminal voltage (V)	4.00	2.42	0.84

(at 759.8 mmHg, 29.91 inHg, 1013 hPa barometric pressure)

- If out of specification, check wire harnesses for open and short. If wire harnesses are in good condition, replace MAP sensor and recheck.

TPS (Throttle position sensor)

TOOL 09930-99320: Digital tester
 09930-89340: 26-pin & 34-pin test cord
DCV Tester range: --- DCV (See chart for range.)

- Turn ignition switch OFF.
- Connect the 24-pin & 34-pin test cord between ECM and wire harness as shown in figure.
- Connect tester probe (“+”, Red) to No.16 terminal.
- Connect tester probe (“-”, Black) to No.49 terminal (or to body ground).
- Turn the ignition switch ON.

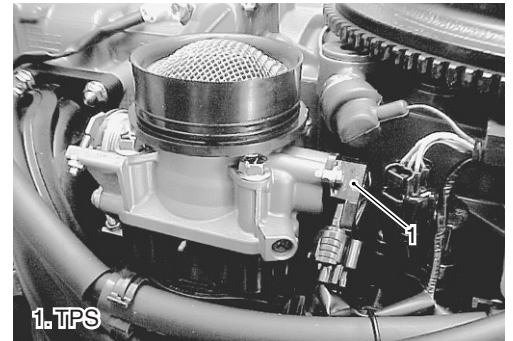

- Check for sensor output voltage.
 Slowly move the throttle lever to open, and check if voltage changes linearly within specification, according to throttle valve opening angle.

Sensor output voltage:
FCT position : Approx. 0.7 V
WOT position : Approx. 3.8 V

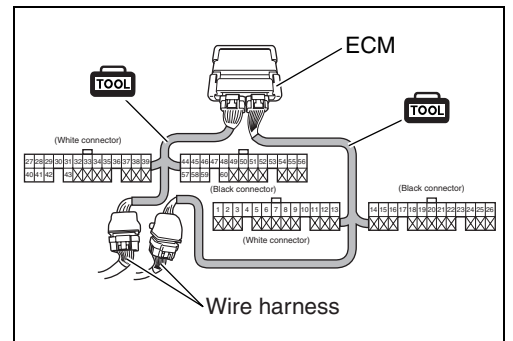

NOTE:
 Do not try to adjust or remove any of the throttle body component parts (Throttle position sensor, throttle valve, throttle stop screw, etc.).
 These components have been factory adjusted to precise specifications.

- If out of specification, check wire harnesses for open and short. If wire harnesses are in good condition, replace throttle body and recheck.

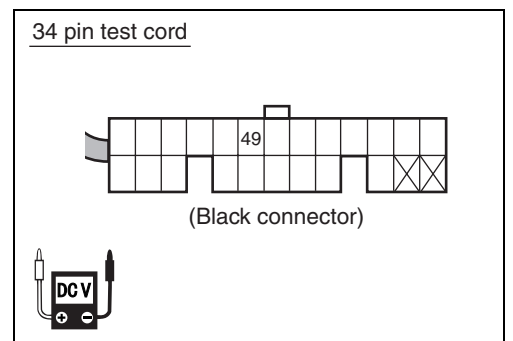
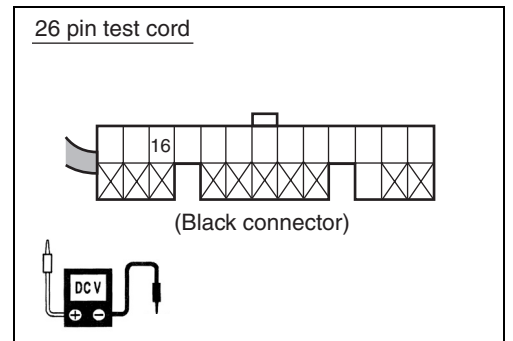

SHIFT POSITION SENSOR

TOOL 09930-99320: Digital tester

09930-89220: 3-pin test cord

DCV **Tester range:** $\overline{\text{DCV}}$ (See chart for range.)

1. Turn ignition switch OFF.
2. Connect 3-pin test cord between shift position sensor and wire harness as shown in figure.
3. Turn the ignition switch ON.
4. Connect tester probe as shown in the illustration and check for sensor power source voltage.

Sensor power source voltage: Approx. 5 V

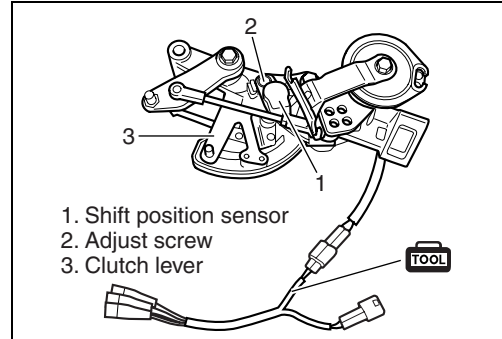

5. Connect tester probe as shown in the illustration. Check for sensor output voltage while operating remo-con handle.

Sensor output voltage:

Shift position	Output voltage
Forward	Approx. 4.1 V
Neutral	Approx. 2.3 V
Reverse	Approx. 0.8 V

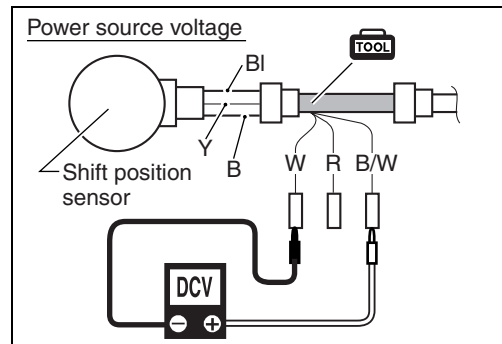

If out of specification:

- 1st Check remo-con cable adjustment, readjust if necessary.
- 2nd Check wire harnesses for open and short.
If wire harnesses are in good condition, replace shift position sensor and recheck.

NOTE:

After installing shift position sensor, check for proper correct function by operating remo-con handle.

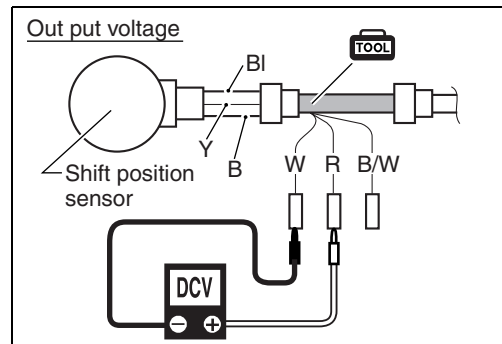

OIL PRESSURE SWITCH

NOTE:

Before checking the oil pressure switch, make sure the engine oil pressure is within specification.

1. Remove the blue lead wire from oil pressure switch.
2. Check the continuity between the switch terminal and engine body ground.

TOOL 09930-99320: Digital tester

TESTER RANGE Tester range: (Continuity)

Engine running	Infinity
Engine stopped	Continuity

If measurement exceeds specification, replace oil pressure switch.

3. Reinstall parts removed earlier.

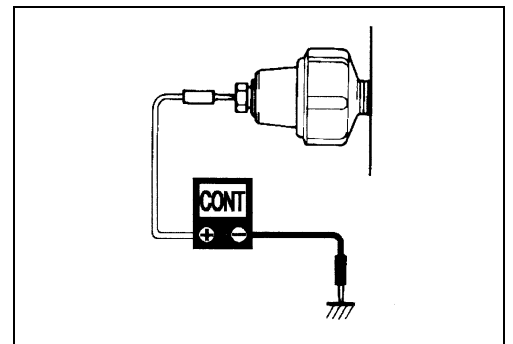
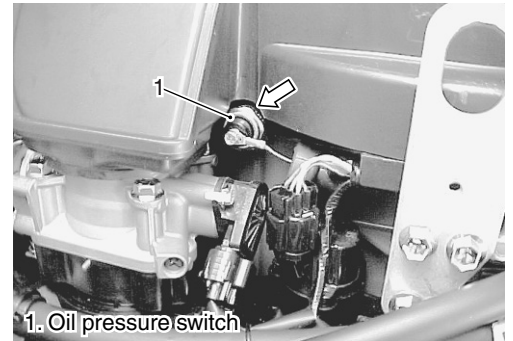

ECM MAIN RELAY

TOOL 09930-99320: Digital tester

TESTER RANGE Tester range: (Continuity)

1. Disconnect ECM main relay from fuse box.
2. Check continuity between terminal ① and ② each time 12 V is applied. Connect positive ⊕ probe to terminal ④, and negative ⊖ probe to terminal ③.



ECM main relay function:

12 V power	Continuity
Applied	Yes
Not applied	No

CAUTION

Do not touch 12 V power supply wires to each other or with other terminals.

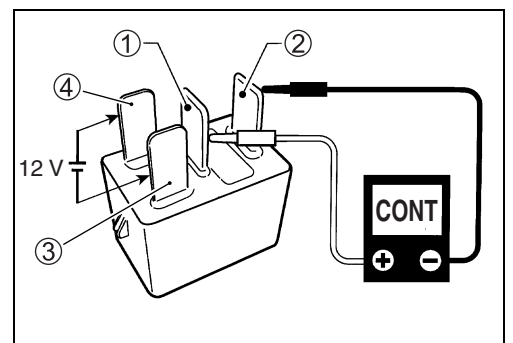

IAC VALVE

1. Disconnect connector from IAC valve.
2. Check each coil of IAC valve for resistance.

Terminals	Resistance
Between "1" and "2"	25 – 34 Ω
"3" and "2"	
"4" and "5"	
"6" and "5"	

If out of specification, replace IAC valve.

3. Remove IAC valve from intake manifold. (See page 3-69.)
4. Connect connector to IAC valve.
5. When the ignition switch is turned ON and OFF, check that the rotary valve turns to open and returns to closed.
6. If the valve does not turn, check the wiring harness for continuity (between ECM and IAC valve) and connector contact condition.

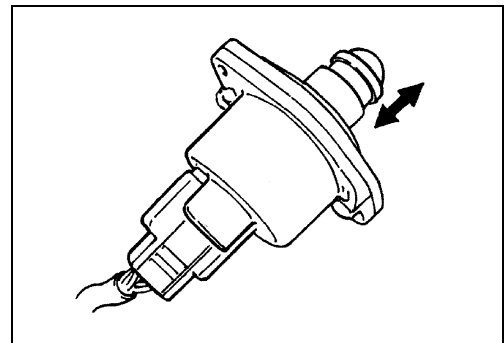
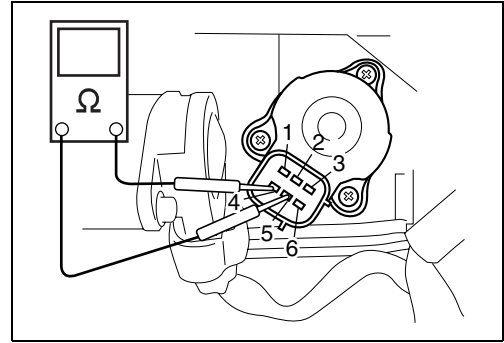
**OCV (Oil control valve)**

1. Remove OCV. (See page 3-71.)
2. Check for operating sound (ticking sound) when battery voltage applied to and removed from the terminals of oil control valve.
3. Check resistance between the two OCV terminals.

OCV resistance: 6.0 – 8.0 Ω

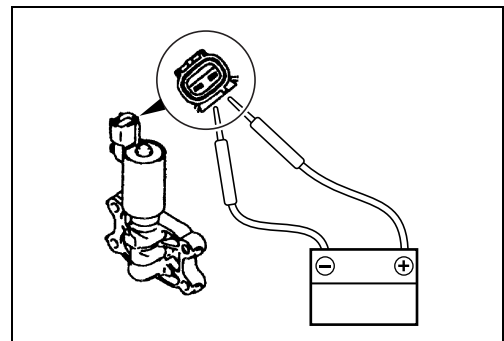
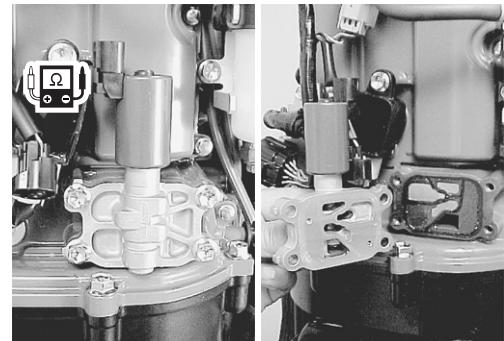

MULTI-STAGE INDUCTION

SYSTEM INSPECTION

- Ensure the depression chamber rod pulls the shut off valves to the complete close position after engine start.

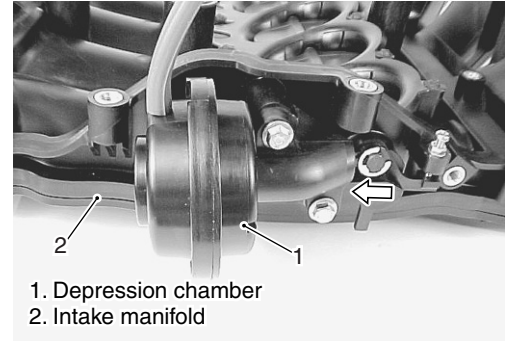

- Ensure the shut off valve return spring returns the shut off valves to the full open position when the engine is turned off.

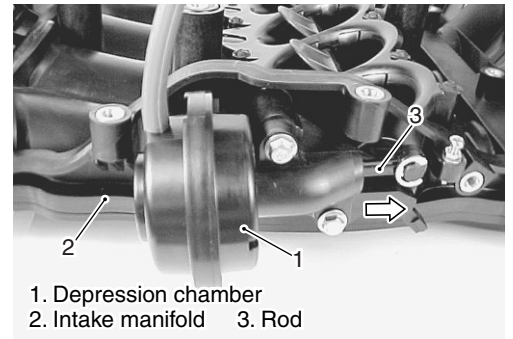

DEPRESSION CHAMBER

 **09917-47011: Vacuum pump gauge**

- Ensure the shut off valve fully close when vacuum is applied to the depression chamber with a vacuum pump tool.

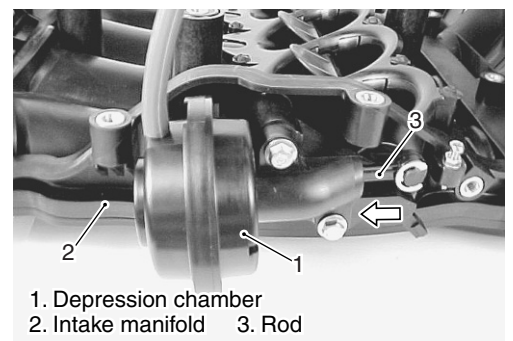
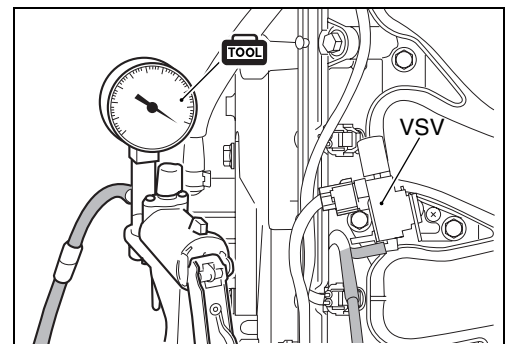

VACUUM PASSAGE INSPECTION

1. Disconnect vacuum hose ① from vacuum switching valve ②.
2. Start engine and run it at idle speed.
Place a finger over vacuum hose end ① and engine vacuum is present.
3. If vacuum is not present, clean vacuum passage with compressed air, start engine and check again for vacuum.

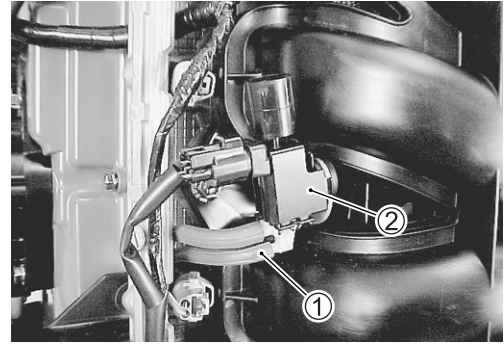
**CHECK VALVE****Inspection**

1. Remove check valve ①.
2. Blow air (moderate pressure) through hose fitting on white side of check valve. Air should not pass through valve from intake manifold (white side ③) to green side ②.
3. Blow air (low pressure) through hose fitting on green side of check valve. Air should pass through to white side.
4. If air passes through valve in Step 2 or high pressure is required to cause air to pass in Step 3, replace check valve.

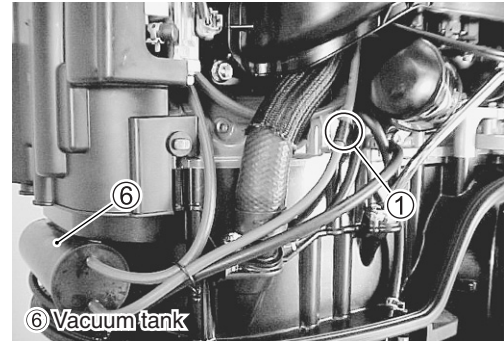
**⚠ WARNING**

DO NOT SUCK air through check valve.
Fuel vapor inside the valve is harmful.

5. Install check valve.

NOTE:

The check valve is directional. Refer to the figure for correct installation.

④ To vacuum tank

⑤ From intake manifold assembly

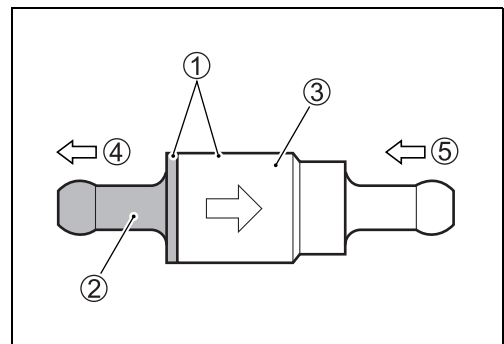

VSV (Vacuum switching valve)

1. With ignition switch OFF, disconnect connector from VSV.
2. Check resistance between VSV terminals.

Resistance of VSV: 37 – 44 Ω

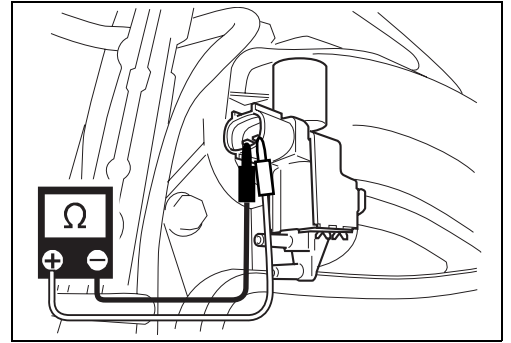

3. Disconnect two hoses from VSV.
4. With 12 V applied between the VSV terminals, check that port (E) connects to port (F) but not to the filter section.
5. Without voltage applied to the VSV terminals, check that port (E) connects to the filter section but not to port (F).

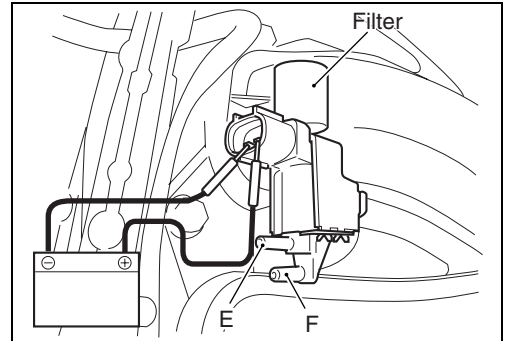

VSV AIR PASSAGE CONTINUITY

VSV electrical power	Passage continuity between ports		
	E	F	Filter section
Power ON	○	○	
Power OFF	○		○

○ — ○ : Air passage

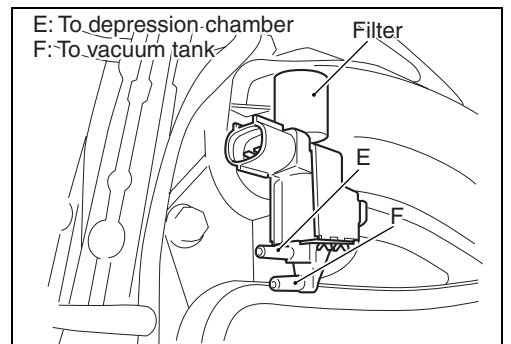

NOTE:

Before removing hoses to check VSV, mark each hose for position to ensure correct hose connection on assembly.

REMOVAL/INSTALLATION

FLYWHEEL

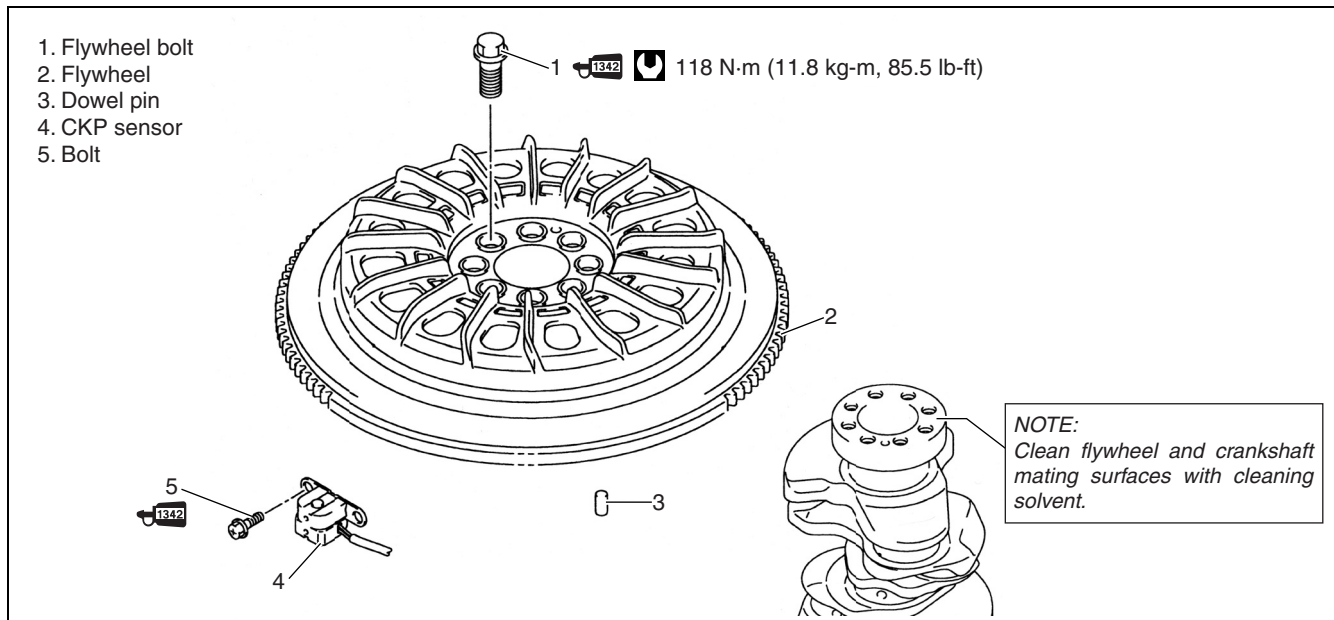

REMOVAL

Prior to removing flywheel:

- Disconnect battery cables from battery.

1. Remove ring gear cover and air intake silencer case. (See page 6-2.)

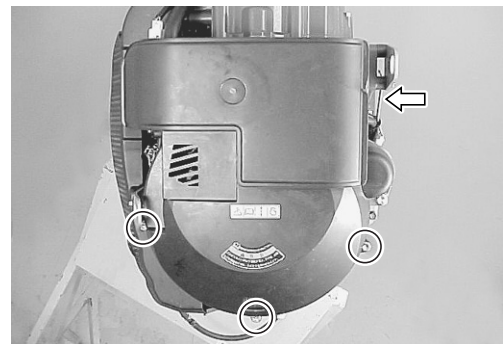

2. To lock the flywheel ① when removing attaching bolts, use special tool shown in figure. Use screws and threaded holes on top of cylinder to attach special tool.

TOOL 09916-99311: Flywheel holder

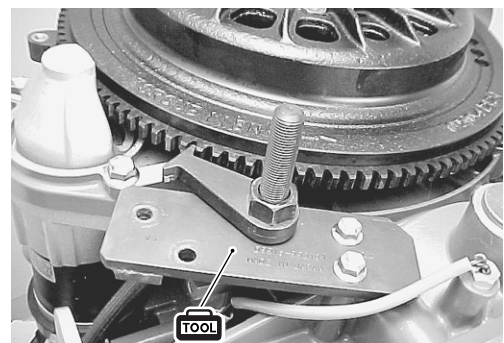
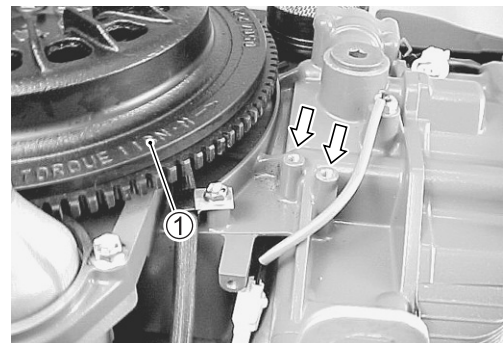

3. Remove eight (8) flywheel bolts ②.
4. Remove flywheel ① and dowel pin ③.

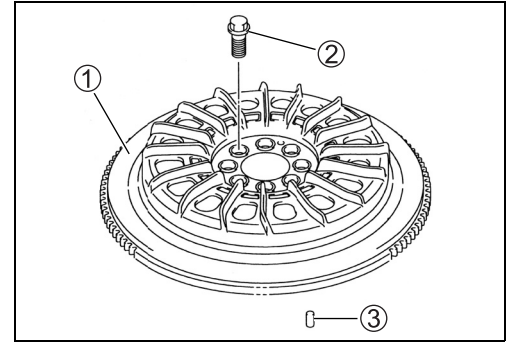

INSTALLATION

Installation is reverse order of removal with special attention to the following steps.

- Install dowel pin ③.
- Install flywheel ① onto crankshaft making sure to align dowel pin hole.

NOTE:

Before installing the flywheel magneto, wipe the crankshaft and flywheel clean.

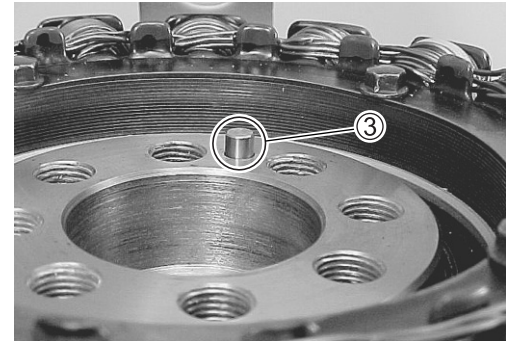

CAUTION

Before tightening flywheel bolts, make sure the flywheel dowel pin hole and crankshaft dowel pin align or severe damage may result.

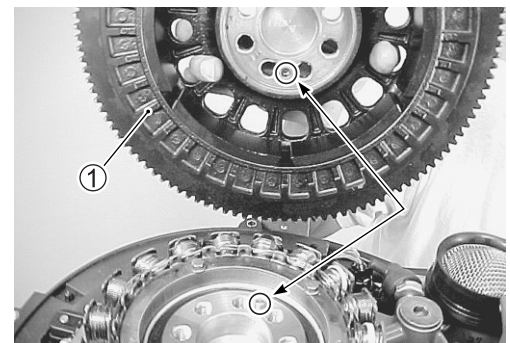

- Apply THREAD LOCK "1342" to flywheel bolts ② before installing.
- Tighten flywheel bolts ② to specified torque. To lock flywheel, use special tool as shown in figure.

 Flywheel bolt: 118 N·m (11.8 kg·m, 85.3 lb-ft)

 09916-99311: Flywheel holder

 99000-32050: THREAD LOCK "1342"



- After installing flywheel and torquing bolts to specification, check air gap between CKP sensor and flywheel reluctor bars.

Air gap: 0.75 mm (0.030 in)

- Check to ensure that all removed parts are back in original position.

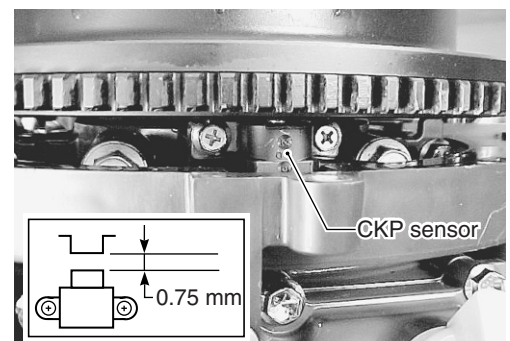

CKP SENSOR

REMOVAL

Prior to removing CKP sensor:

- **Disconnect battery cables from battery.**

1. Remove flywheel. (See page 3-66.)
2. Remove the electric parts holder. (See page 4-30.)
3. Disconnect CKP sensor lead wire connector in electric parts holder.
4. Remove two (2) screws ① and CKP sensor ②.

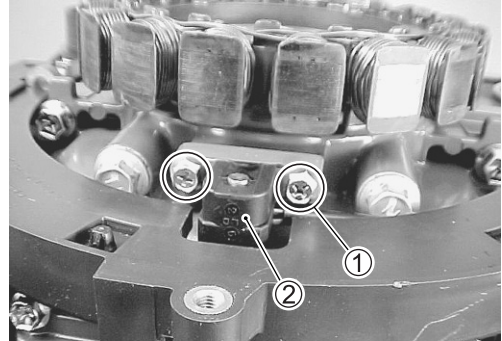
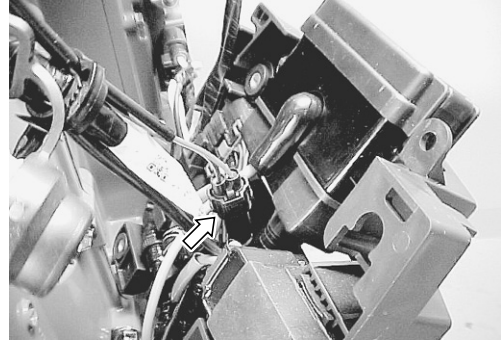

INSTALLATION

Installation is reverse order of removal with special attention to the following steps.

- Apply THREAD LOCK “1342” to the sensor mounting screws.

 **99000-32050: THREAD LOCK “1342”**

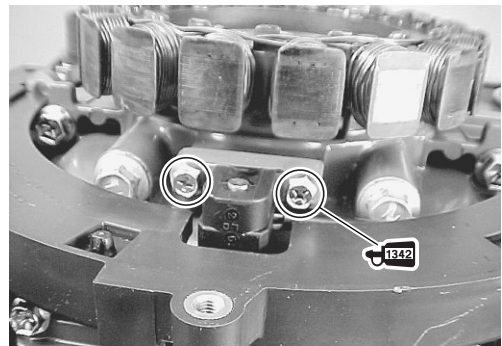

- Install CKP sensor with air gap of 0.75 mm between sensor and reluctor bar on flywheel, then tighten sensor mounting screws securely.

Air gap: 0.75 mm (0.030 in)

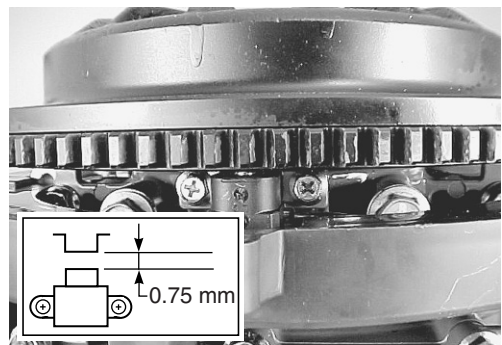

- Check to ensure that all removed parts are back in original position.
- Check wire routing. (See page 11-4 to 11-10.)

CMP SENSOR

REMOVAL

1. Disconnect CMP sensor lead wire connector at sensor.
2. Remove bolt, CMP sensor and sensor cover.

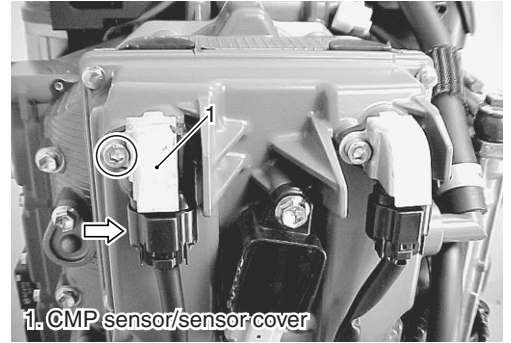

INSTALLATION

Installation is reverse order of removal.

- Install CMP sensor and sensor cover, then tighten sensor mounting screw securely.
- Connect sensor lead wire connector to CMP sensor.

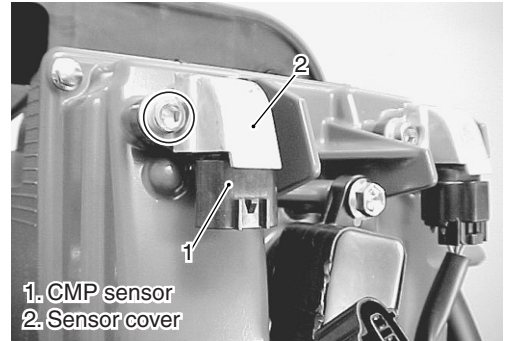

IAC VALVE

REMOVAL

1. Remove flywheel. (See page 3-66.)
2. Disconnect IAC valve lead wire connector at IAC valve.
3. Remove screws and IAC valve.

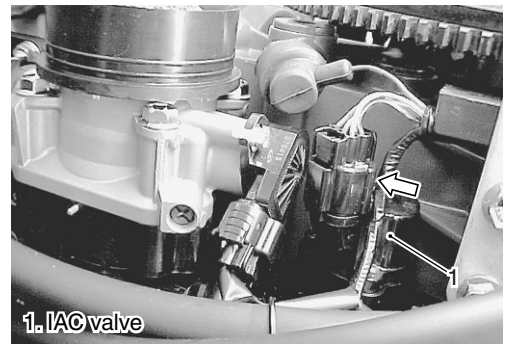

INSTALLATION

Installation is reverse order of removal.

- Install IAC valve, then tighten mounting screws securely.
- Connect IAC valve lead wire connector to IAC valve.
- Check to ensure that all removed parts are back in original position.

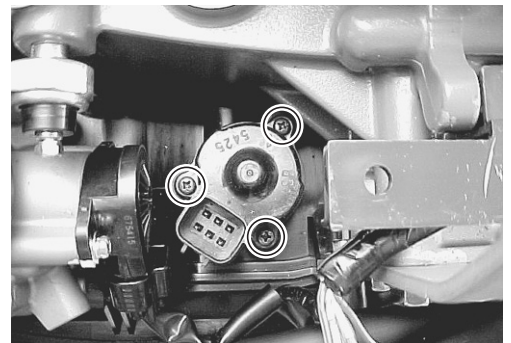

OIL PRESSURE SWITCH

REMOVAL

1. Remove the ring gear cover and air intake silencer case ①.
(See page 6-2.)
2. Remove the three bolts and fuel hose guard ②.
3. Loosen screw ③ and disconnect blue lead wire ④ from switch.
4. Remove oil pressure switch from cylinder block.

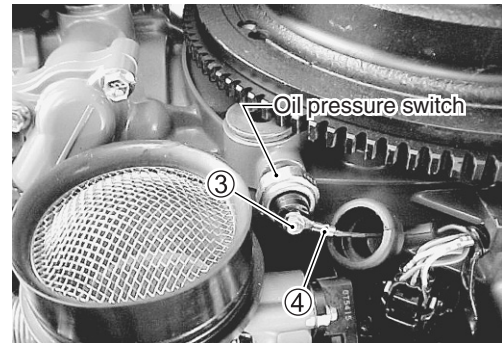
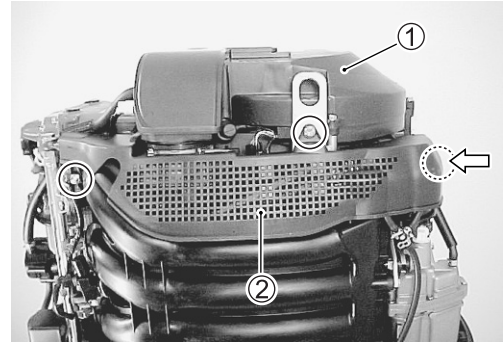

INSTALLATION

Installation is reverse order of removal with special attention to the following steps.

- Before installing oil pressure switch, wrap screw threads with sealing tape then tighten switch to specified torque.

NOTE:

Cut off any excess sealing tape from switch threads before installation.

Oil pressure switch: 13 N·m (1.3 kg·m, 9.5 lb-ft)

- Install the ring gear cover and air intake silencer case.
- Start engine and check oil pressure switch for oil leakage.
Reseal switch if oil leakage is found.

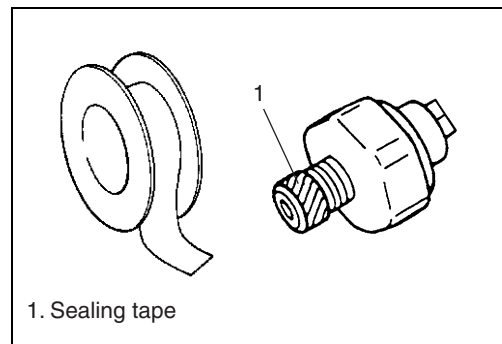

OCV (Oil control valve)

REMOVAL

1. To remove the cover ①, pull the upper part outward, then lift up.
2. Disconnect OCV lead wire connector at OCV.
3. Remove the four (4) bolts securing OCV, then remove OCV and discard OCV gasket.

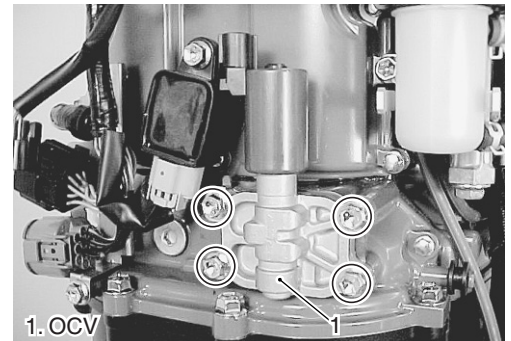
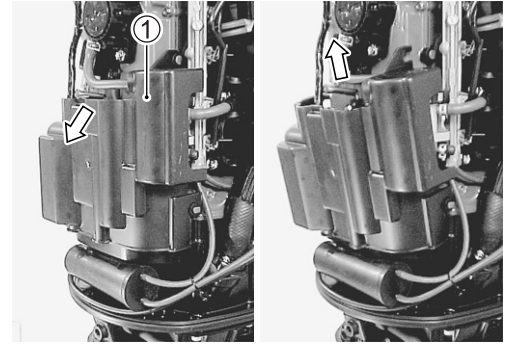

INSTALLATION

Installation is reverse order of removal with special attention to the following steps.

- Install gasket and OCV, then tighten bolts securely.

NOTE:

Position the OCV gasket tab as shown at right.

CAUTION

Do not reuse the OCV gasket, always replace with new one.

 OCV bolt: 12 N·m (1.2 kg·m, 8.6 lb·ft)

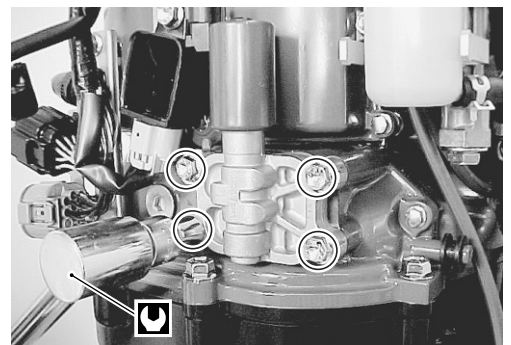
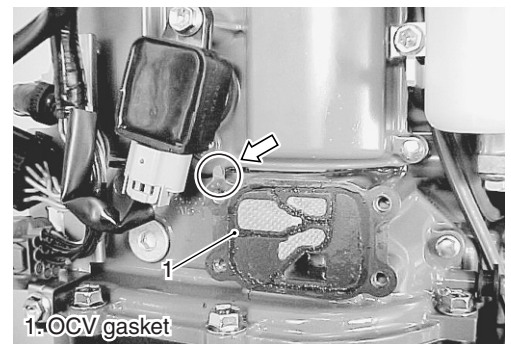

- Check to ensure that all removed parts are back in original position.

TROUBLESHOOTING

⚠ WARNING

Before starting troubleshooting, read and follow the “PRECAUTION ON SYSTEM INSPECTION” section on page 3-47.

In this section, troubleshooting procedures are based on the assumption that “Low pressure fuel system” and “mechanical components (power unit, lower unit, etc.)” are normal.

NOTE:

For troubleshooting of “Starter motor will not run”, see page (4-13).

CHART 1: SELF-DIAGNOSTIC CODE “3-4” MAP sensor

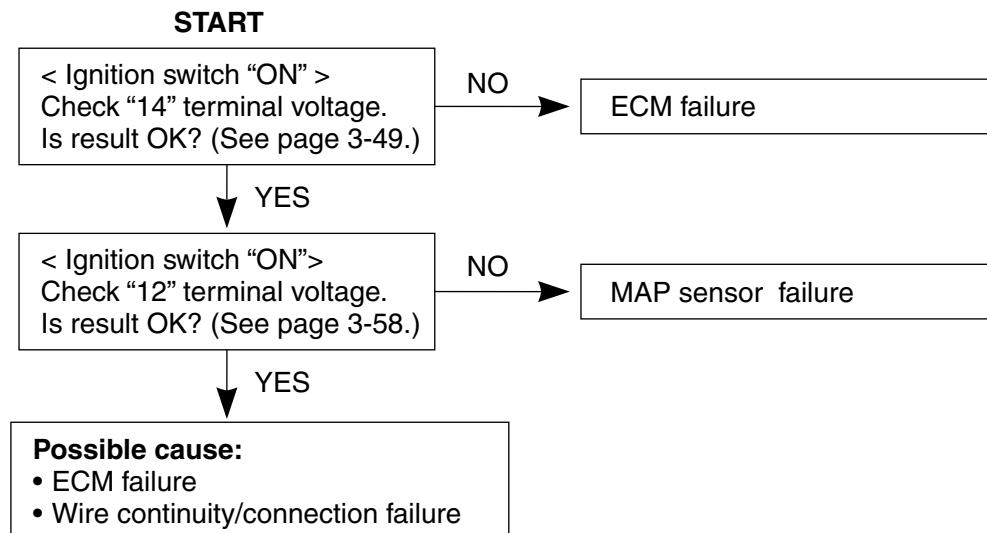

CHART 2: SELF-DIAGNOSTIC CODE “3-1” IAC system

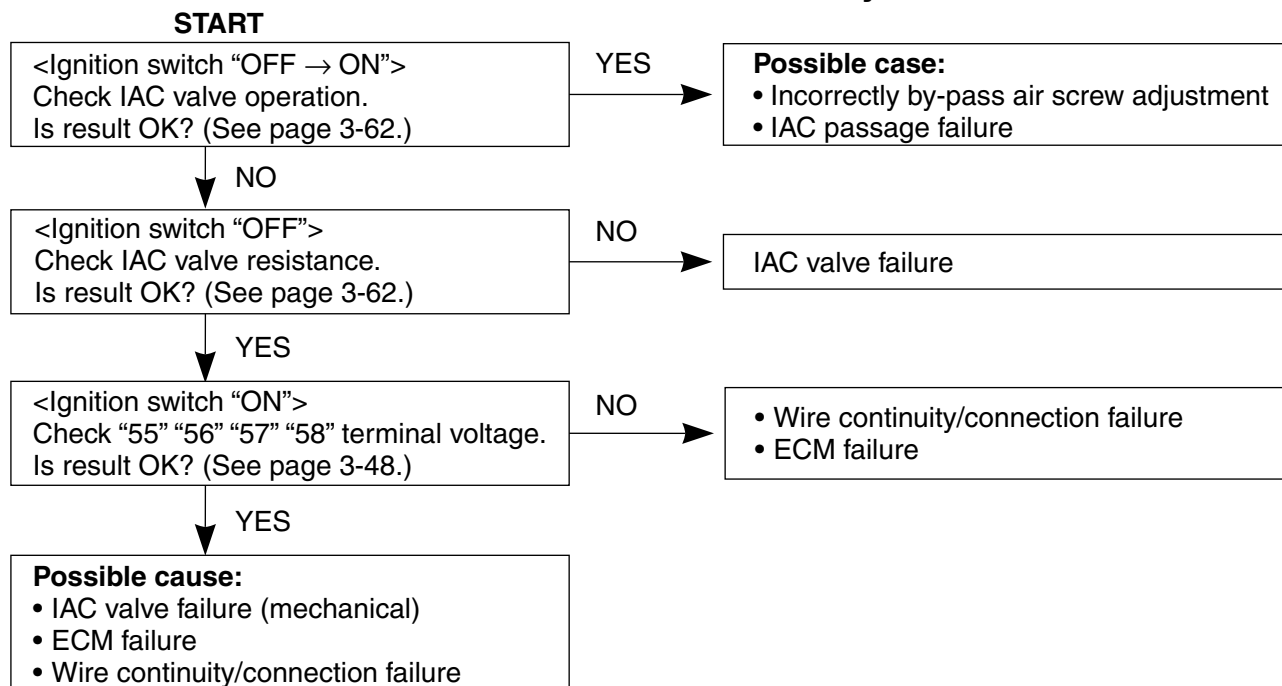

CHART 3: SELF-DIAGNOSTIC CODE “1-4” Cylinder temp. sensor**CHART 4: SELF-DIAGNOSTIC CODE “2-3” IAT sensor****CHART 5: SELF-DIAGNOSTIC CODE “4-2” CKP sensor****CHART 6: SELF-DIAGNOSTIC CODE “2-4” CMP sensor**

CHART 7: SELF-DIAGNOSTIC CODE “2-2” Air intake system**CHART 8: SELF-DIAGNOSTIC CODE “3-2” MAP sensor 2****CHART 9: SELF-DIAGNOSTIC CODE “1-5” Ex. mani. temp. sensor**

CHART 10: SELF-DIAGNOSTIC CODE “4-3” Fuel injector**CHART 11: SELF-DIAGNOSTIC CODE “2-1” Throttle position sensor****CHART 12: SELF-DIAGNOSTIC CODE “1-2” Shift position sensor**

CHART 13: SELF-DIAGNOSTIC CODE “2-6” CMP sensor (VVT)**CHART 14: SELF-DIAGNOSTIC CODE “5-2” VVT advance****CHART 15: SELF-DIAGNOSTIC CODE “3-3” Neutral switch**

CHART 16: SELF-DIAGNOSTIC CODE “4-1” Model discrimination**CHART 17: SELF-DIAGNOSTIC CODE “6-2” OCV****CHART 18: SELF-DIAGNOSTIC CODE “1-1” Over charging****NOTE:**

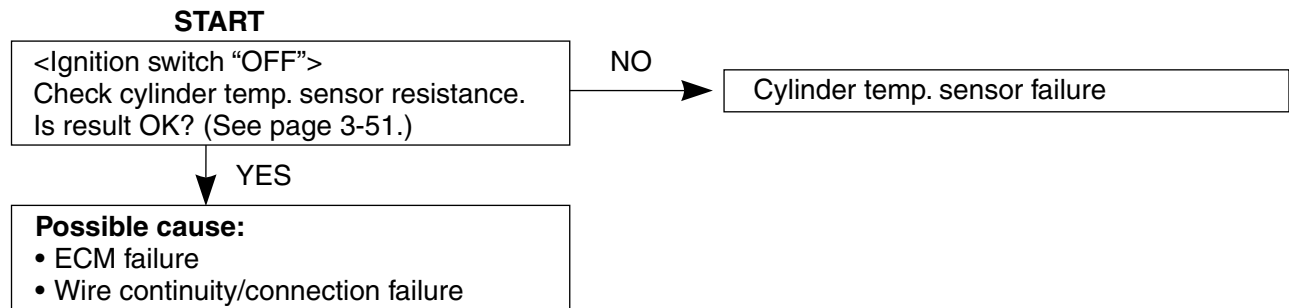
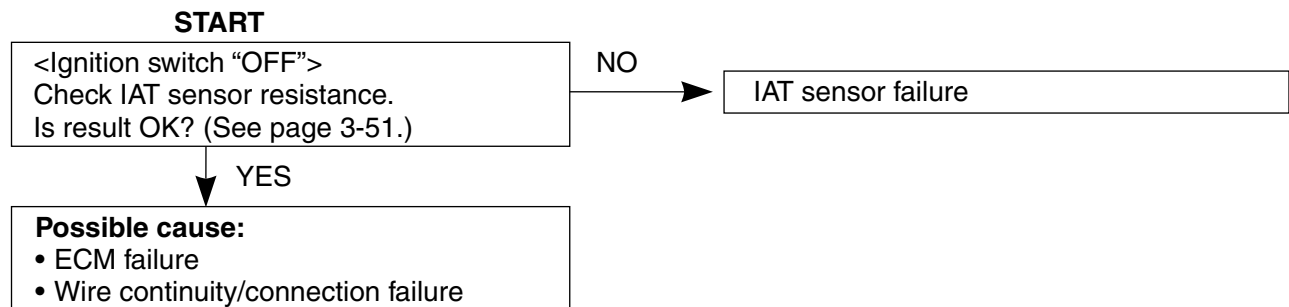
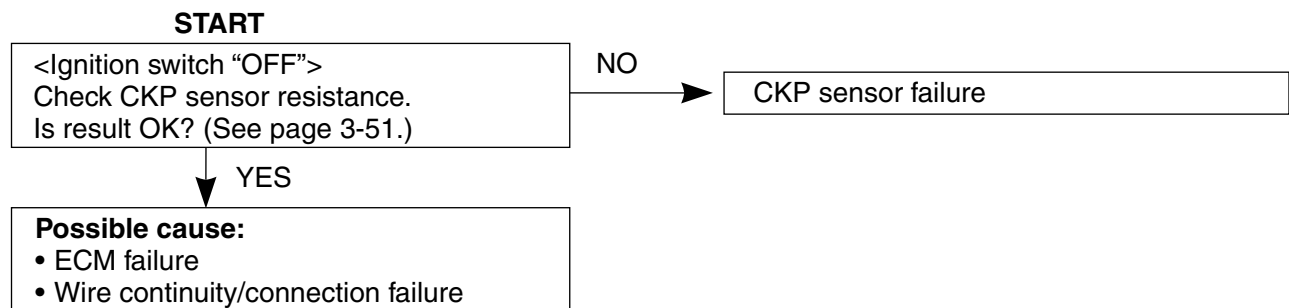
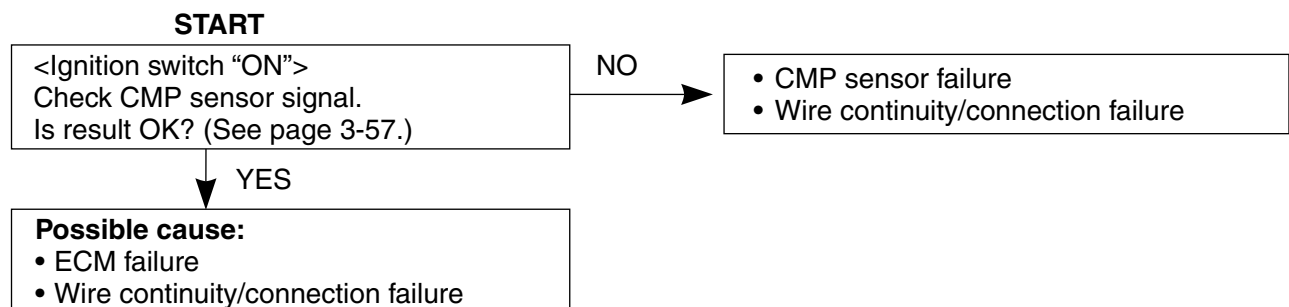
This self-diagnostic code indication may be canceled by turning ignition switch ON, because ECM detects battery voltage.

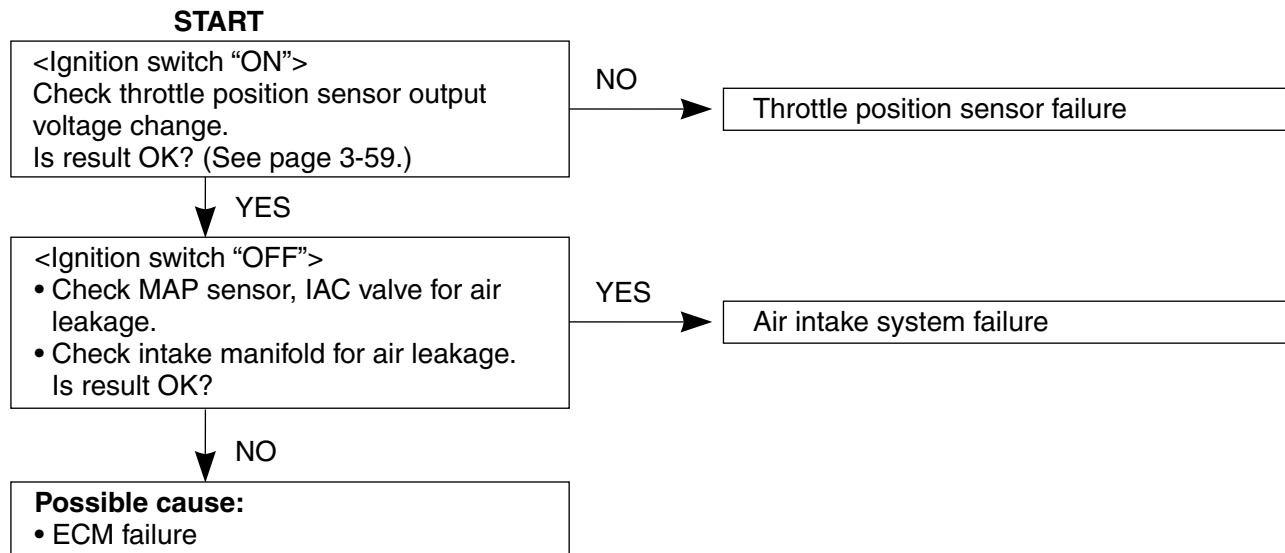
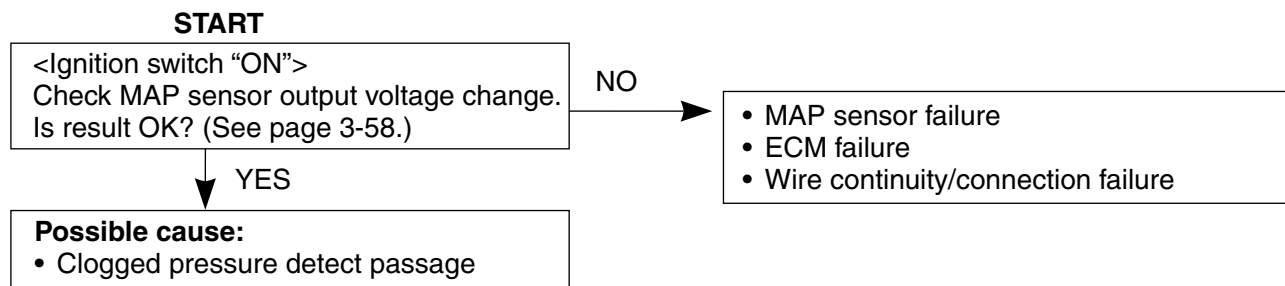
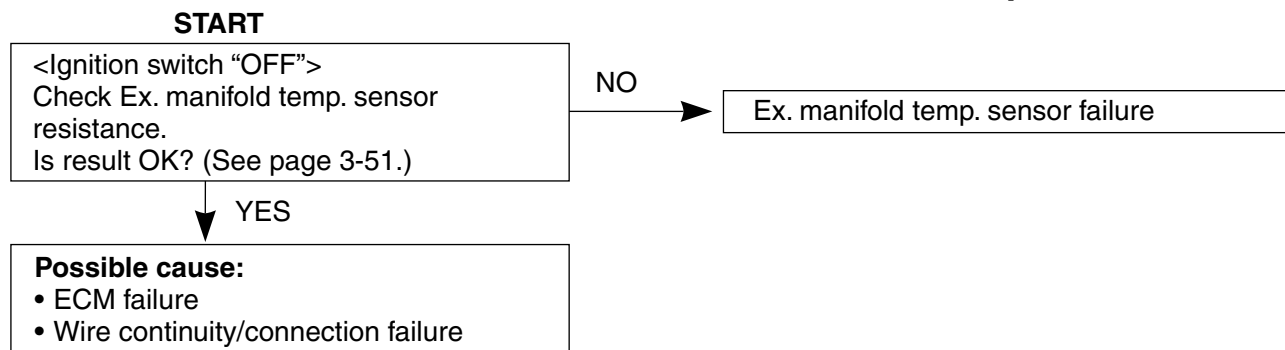
NOTE 1:

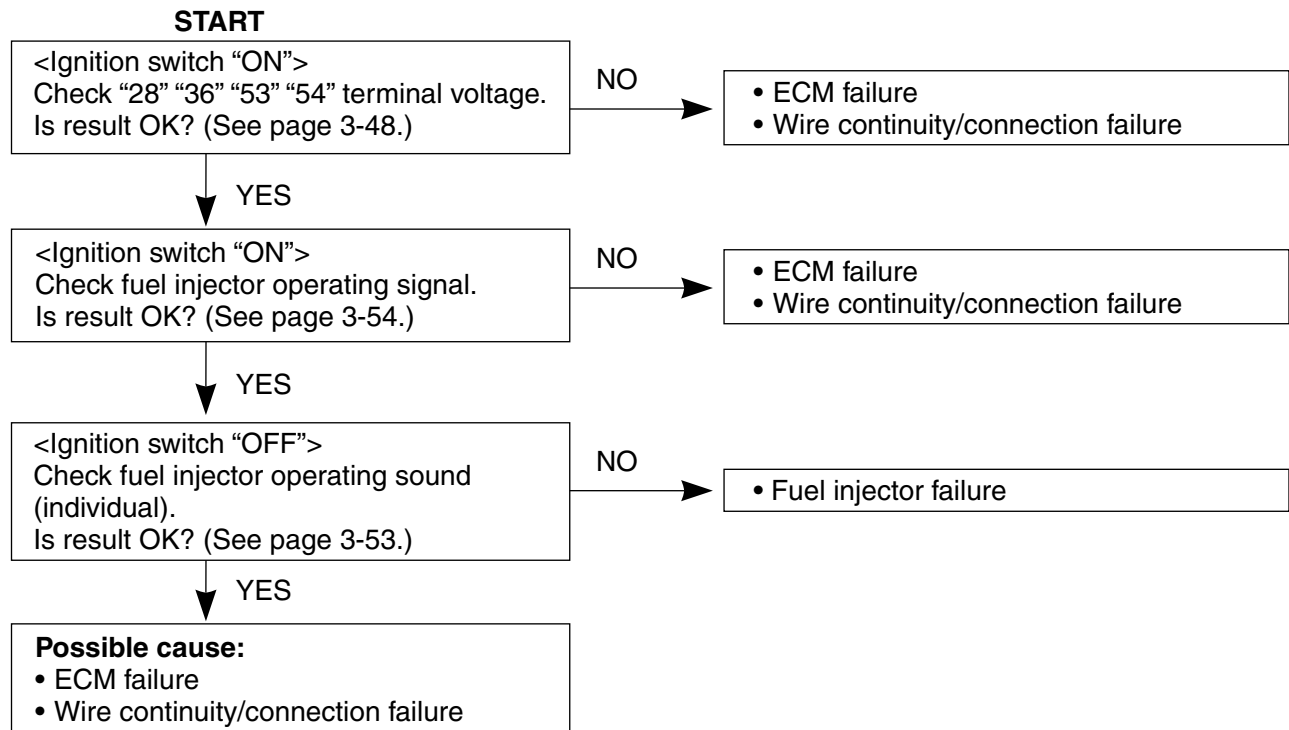
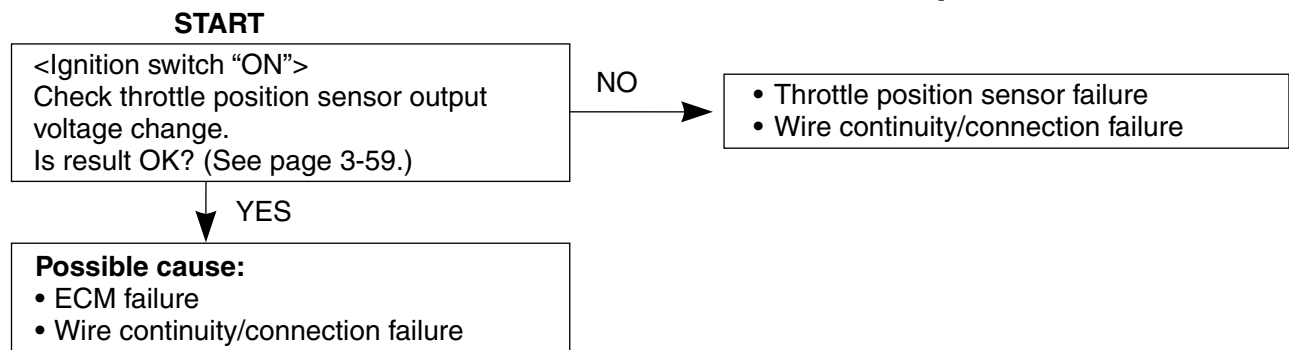
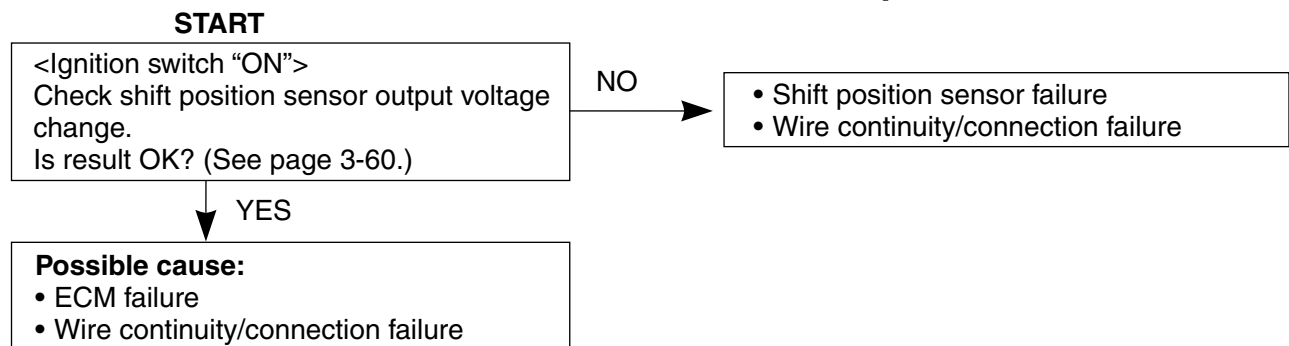
It is difficult to check rectifier & regulator completely. Before replacing with new one, check if its ground point has good electrical contact.

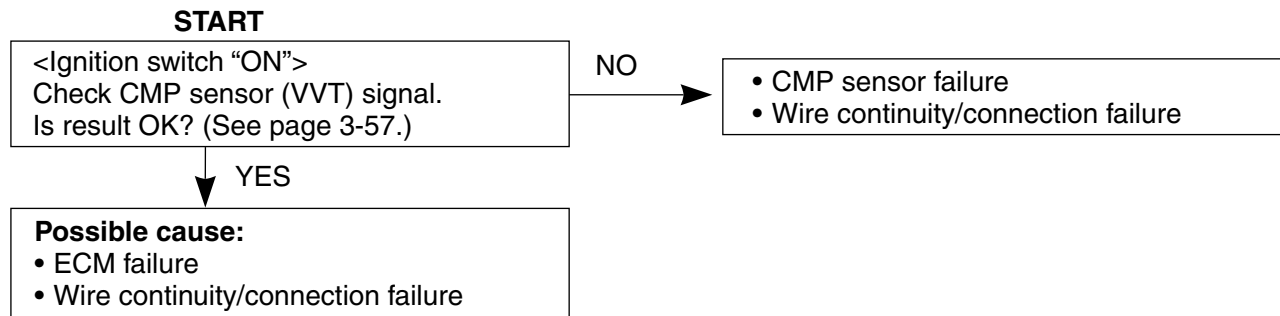
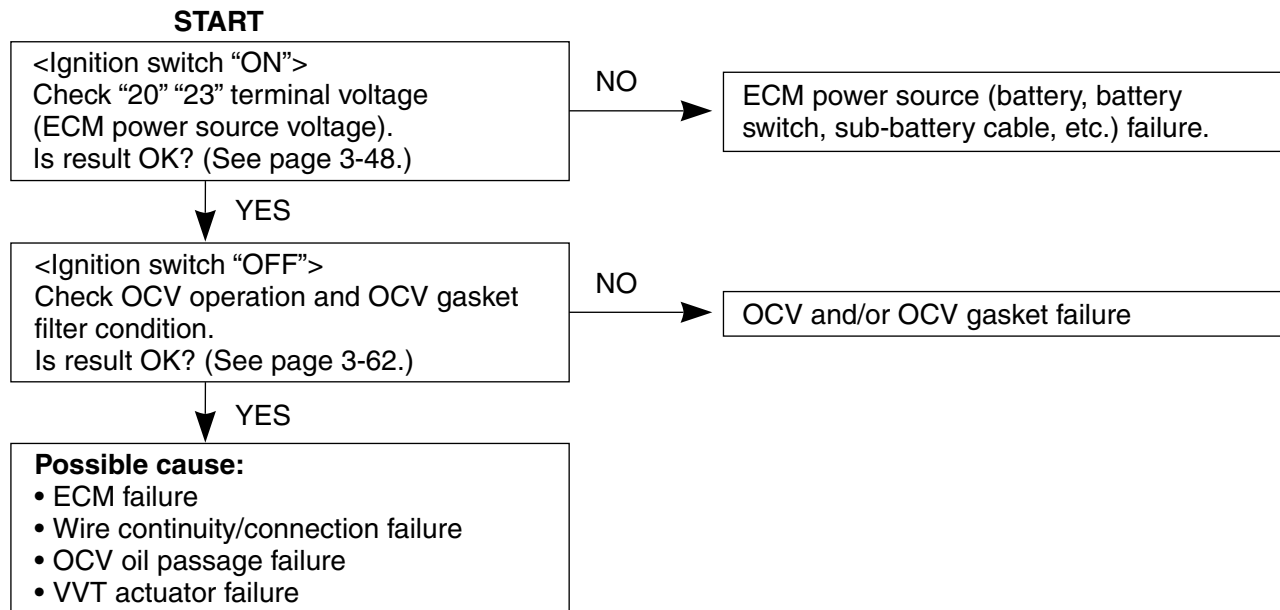
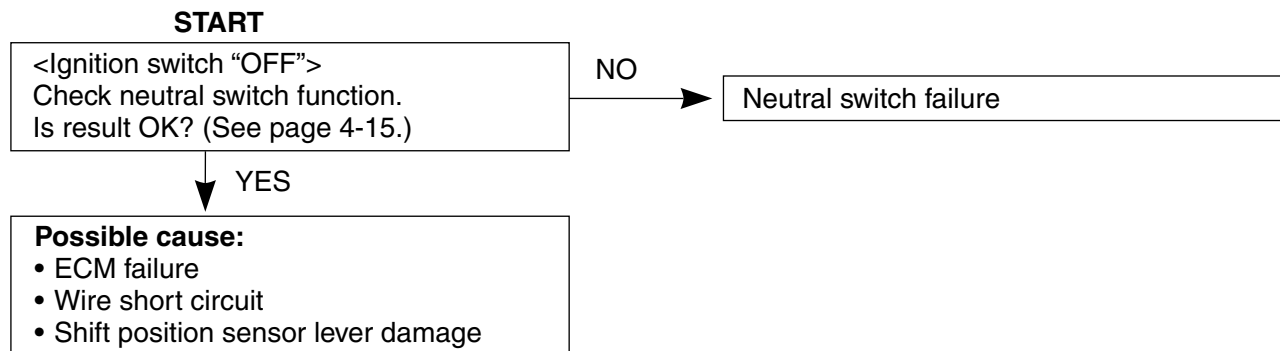
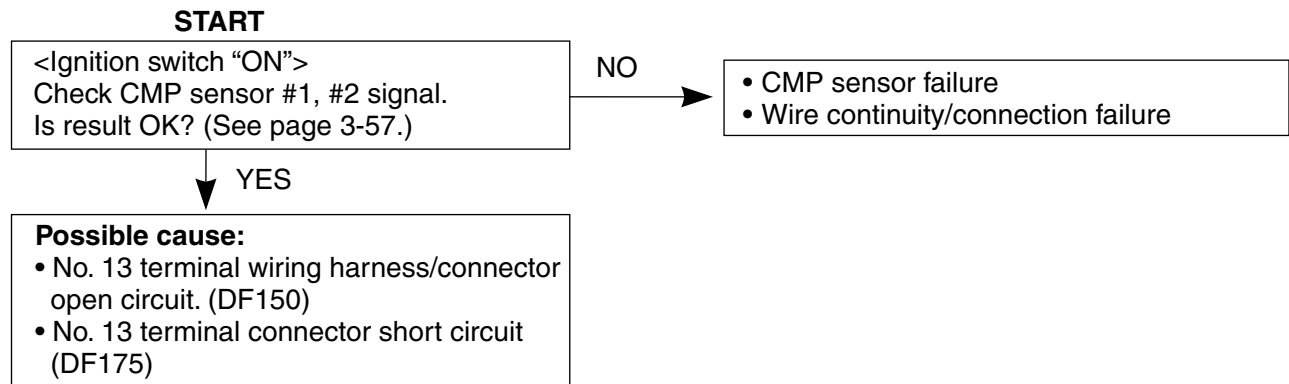
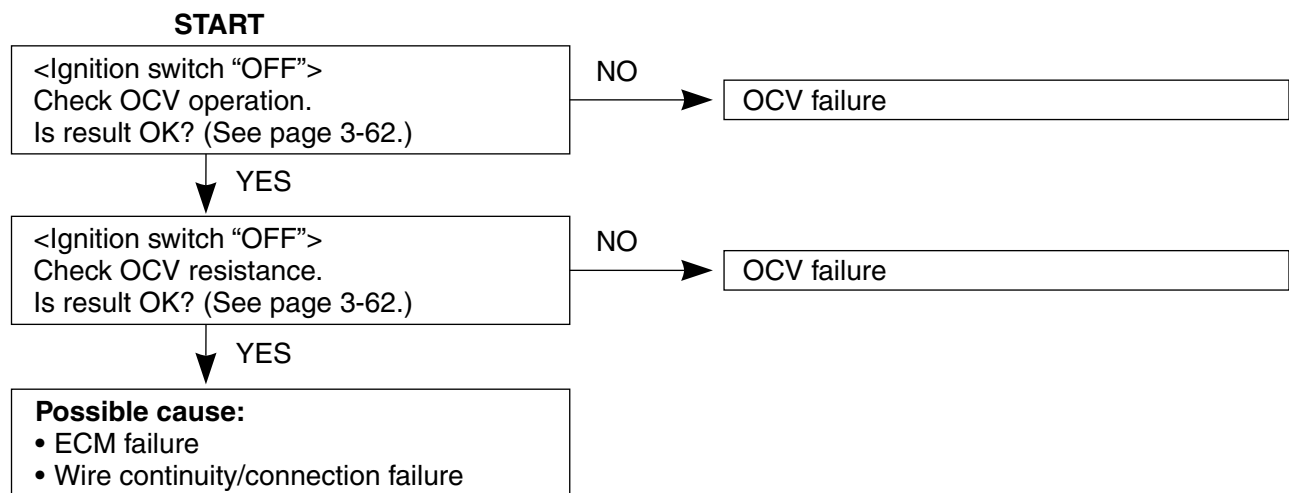
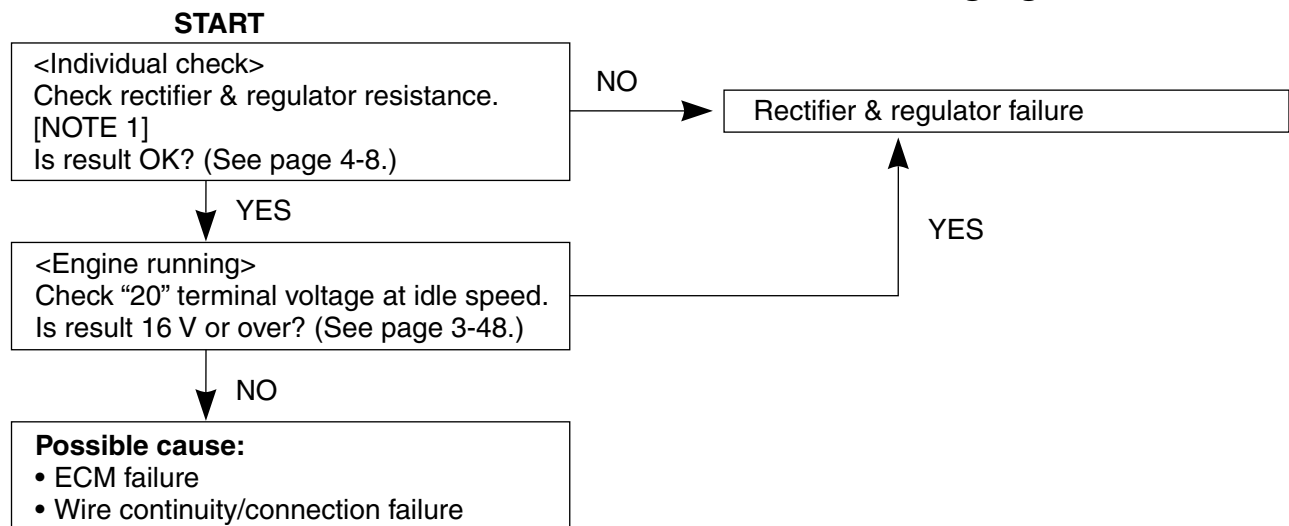
CHART 19: ENGINE CRANKED, BUT NOT START (OR STOPS SHORTLY AFTER STARTING)

Before starting the troubleshooting, make sure that:

- There is no self-diagnostic code indication.
- Emergency stop switch plate is set in place.

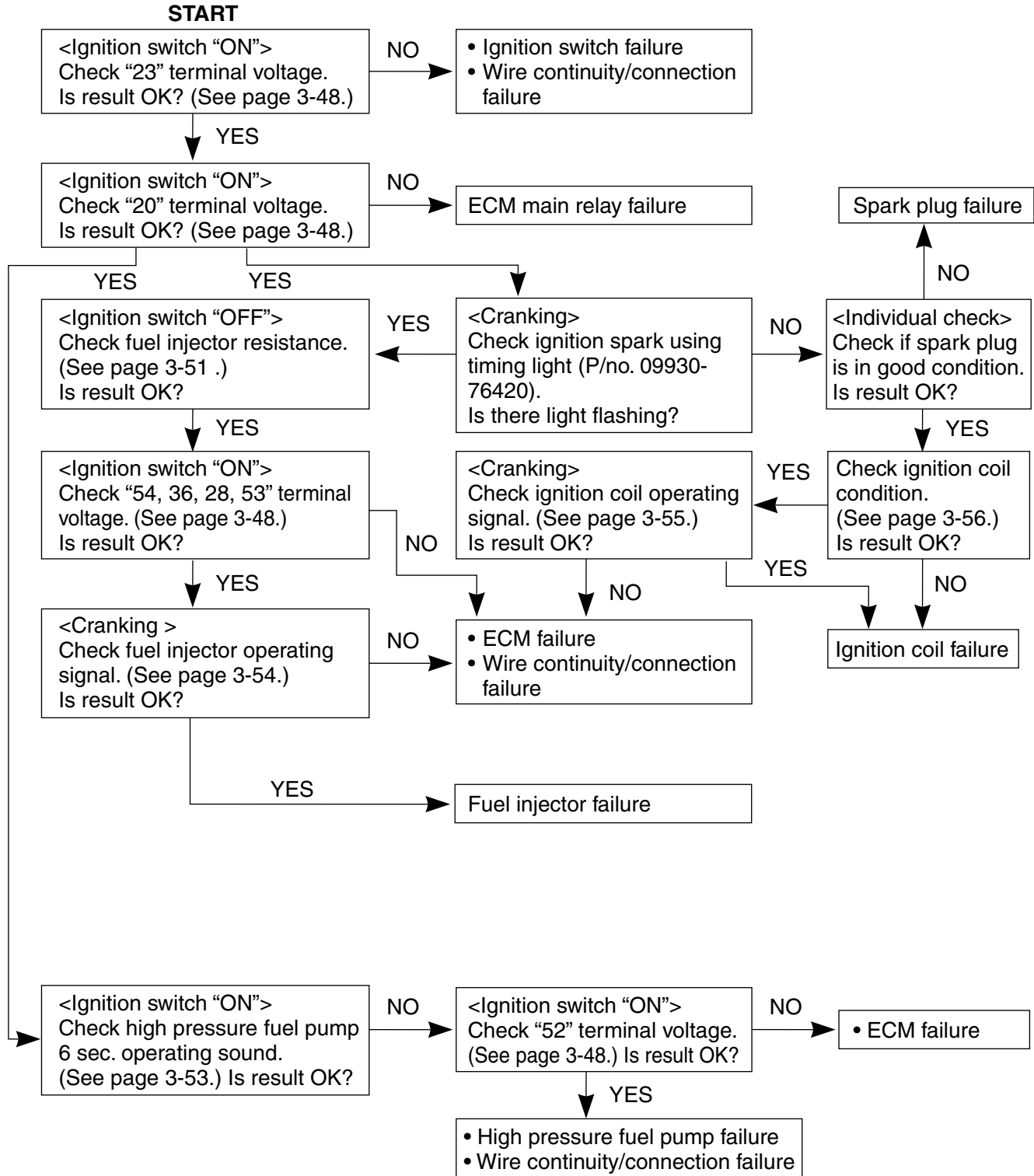
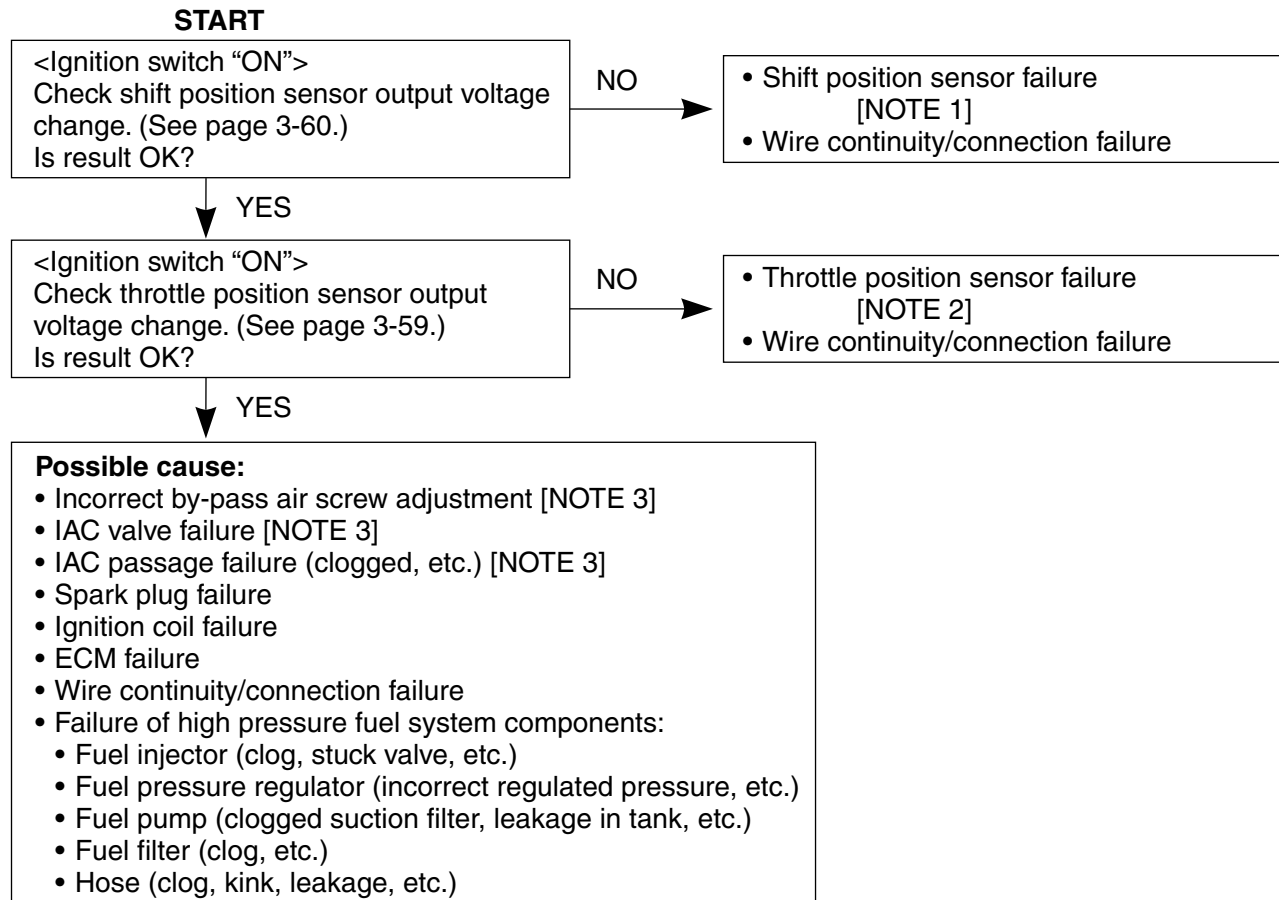

CHART 20: UNSTABLE IDLING/TROLLING (OR ENGINE TENDS TO STALL)

Before starting this troubleshooting, make sure that:

- There is no self-diagnostic code indication.



NOTE 1

If shift position sensor has failed (while engine running), engine will tend to stall when shifting into gear.

NOTE 2

If throttle position sensor has failed, engine will tend to stall when decelerating.

NOTE 3

- The self-diagnostic code "3-1" may not be indicated because IAC valve condition depends on ECM control. (See page 3-40.)
- If IAC valve has failed, "Fast-idle function (warm-up mode)" won't operate.