

OUTBOARD MOTOR
HONDA

BF20

OWNER'S MANUAL

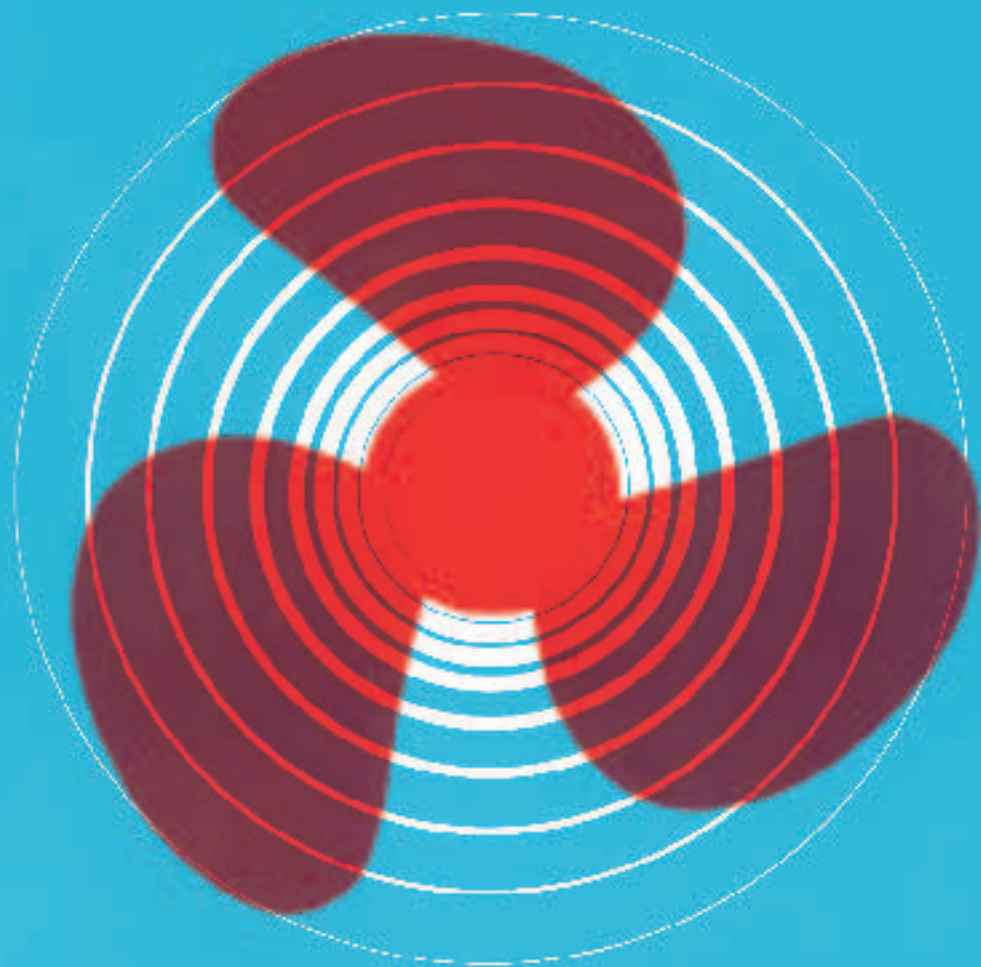

Thank you for purchasing a Honda Outboard Motor.

This manual covers operation and maintenance of the Honda Outboard Motor. All information in this publication is based on the latest product information available at the time of approval for printing.

Honda Motor Co., Ltd. reserves the right to make changes at any time without notice and without incurring any obligation.

No part of this publication may be reproduced without written permission.

This manual should be considered a permanent part of the Outboard Motor and should remain with the Outboard Motor when it is sold.

Pay special attention to statements preceded by the following words:

 **WARNING** Indicates a strong possibility of severe personal injury or loss of life if instructions are not followed.

CAUTION: Indicates a possibility of personal injury or equipment damage if instructions are not followed.

NOTE: Gives helpful information.

If a problem should arise, or if you have any questions about the Outboard Motor, consult an authorized Honda dealer.

 **WARNING** Honda Outboard Motors are designed to give safe and dependable service if operated according to instructions. Read and understand the Owner's Manual before operating the Outboard Motor. Failure to do so could result in personal injury or equipment damage.

CONTENTS

1. SAFETY INSTRUCTIONS	4
2. WARNING LABELS	5
3. COMPONENT IDENTIFICATION	6
4. INSTALLATION.....	8
5. PRE-OPERATION CHECK	10
6. STARTING THE ENGINE	13
7. OPERATION	18
8. STOPPING THE ENGINE	23
• High altitude operation	24
9. MAINTENANCE	25
10. TRANSPORTING/STORAGE.....	34
11. TROUBLESHOOTING	36
12. SPECIFICATIONS.....	37
13. OPTIONAL PARTS.....	38
14. WARRANTY SERVICE.....	39

1. SAFETY INSTRUCTIONS

WARNING

To ensure safe operation—

- Understand the operation of all controls, and know how to stop the engine quickly —**READ THIS OWNER'S MANUAL CAREFULLY.**
- Do not exceed the boat manufacturer's power recommendation, and be sure the outboard motor is properly mounted.
- Never permit anyone to operate the outboard motor without proper instruction.
- Stop the engine immediately if any passenger falls overboard.
- Do not run the motor while the boat is near any person in the water.
- Exhaust gas contains poisonous carbon monoxide. Never run the outboard motor in a closed garage or confined area.
- Gasoline is extremely flammable and is explosive under certain conditions. Refuel in a well ventilated area with the engine stopped.
- Do not smoke or allow flames or sparks where the engine is refueled or where gasoline is stored.
- Do not overfill the fuel tank, and make sure the fuel tank cap is securely closed after refueling.
- Be careful not to spill fuel when refueling. Fuel vapor or spilled fuel may ignite. If any fuel is spilled, make sure the area is dry before starting the engine.

2. WARNING LABELS

WARNING LABEL LOCATIONS

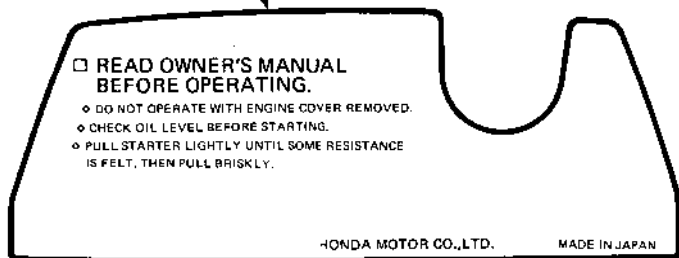
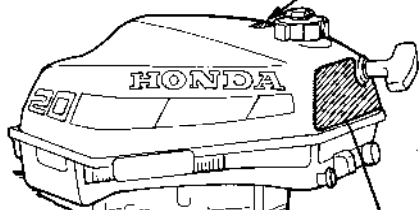

3. COMPONENT IDENTIFICATION

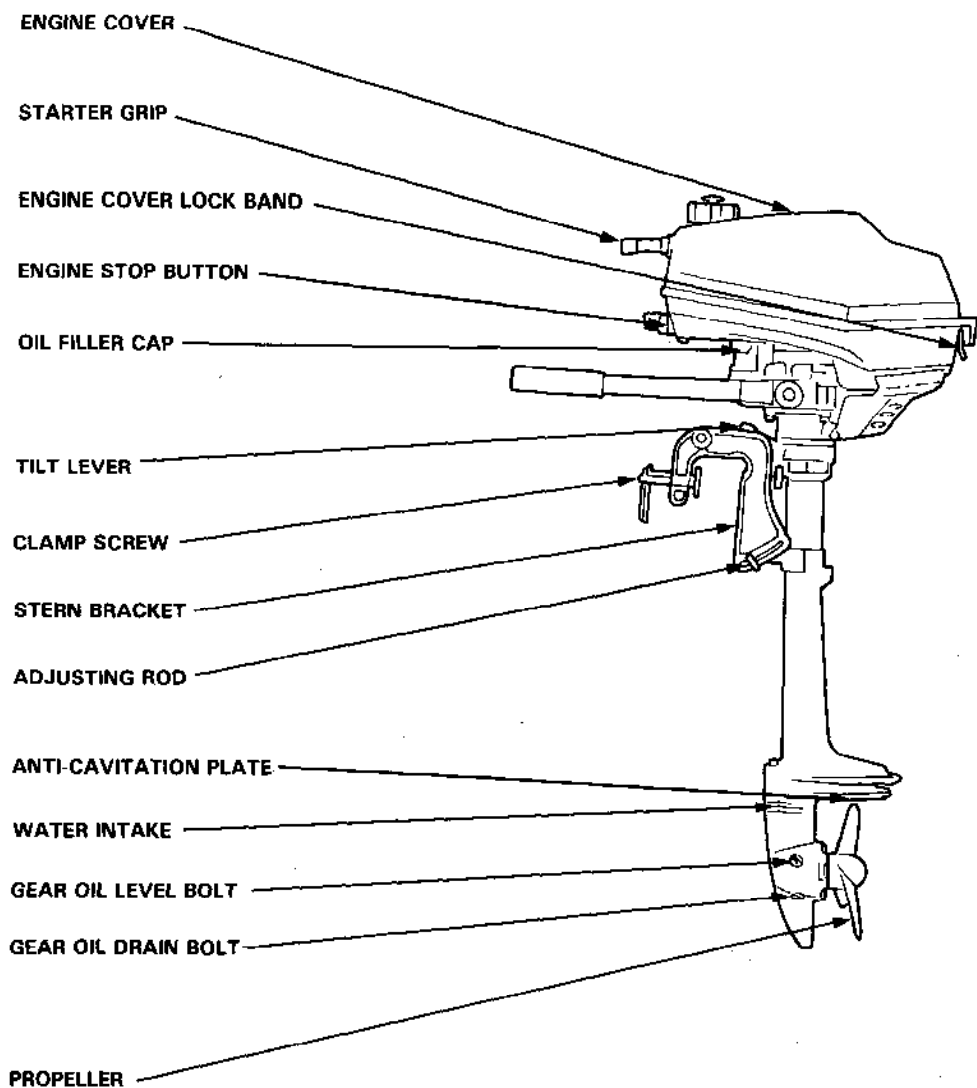

(BF20S)

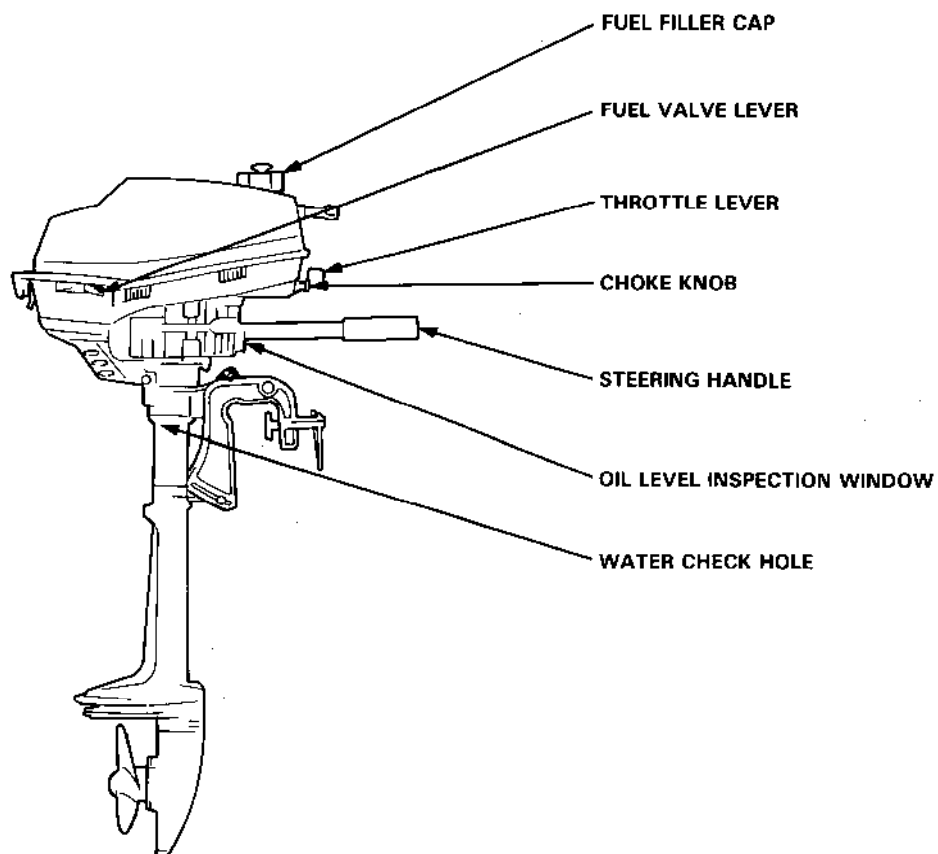

(BF20S)

4. INSTALLATION

It is your responsibility to choose a boat suitable for the engine (2 horsepower).

WARNING Do not exceed the boat manufacturer's power recommendation. Damage and injury may result.

1. Installation Position

Install at the stern at the center line of the boat.

2. Installation Height

Make sure that the transom height is correct for the motor. Incorrect installation height will reduce performance.

The motor should be installed so that the anti-cavitation plate is 2–5 cm (0.8–2.0 in) below the bottom of the boat.

CAUTION: The water level must be at least 4 inches above the anti-cavitation plate, otherwise the water pump may not receive sufficient cooling water, and the extension case will overheat.

3. Motor Attachment

Attach the stern bracket to the transom and tighten the clamp screws.

CAUTION:

- While operating the boat, check the tightness of the clamp screws occasionally.
- Tie a rope through the hole in the stern bracket and secure the other end of the rope to the boat. This will prevent accidental loss of the motor.

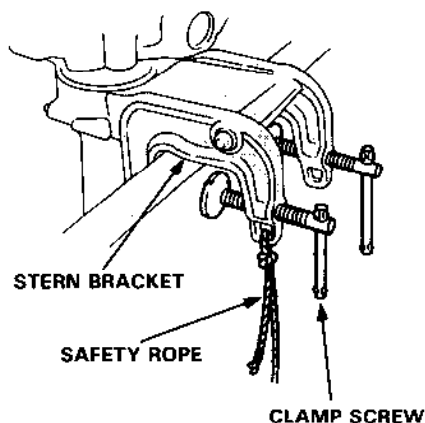
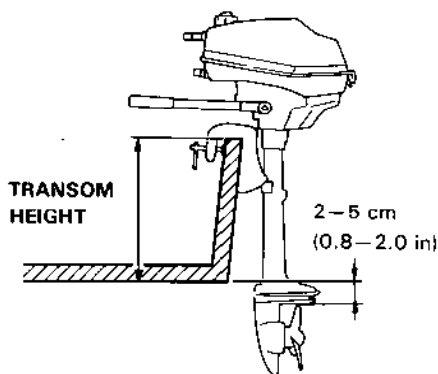
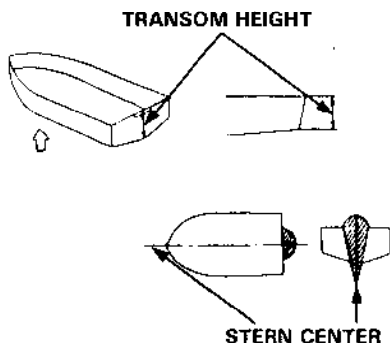

4. Motor Angle

Adjust the motor so the axis of the propeller is parallel with the water surface.

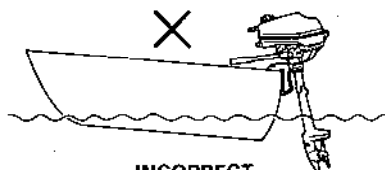

INCORRECT
CAUSES BOAT TO "SQUAT"

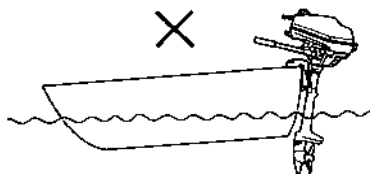

INCORRECT
CAUSES BOAT TO "PLOW"

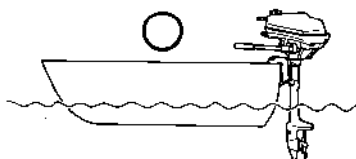

CORRECT
GIVES MAXIMUM PERFORMANCE

5. Motor Angle Adjustment

If the propeller axis is not parallel with the water, adjust the angle of the motor by relocating the adjusting bolt on the stern brackets. There are four adjustment positions.

1. Loosen the wing nut to free the adjusting bolt.
2. Adjust the angle of the motor, and tighten the wing nut. Be sure that the bolt head and wing nut are seated in one of the four recesses on the adjustment slot.

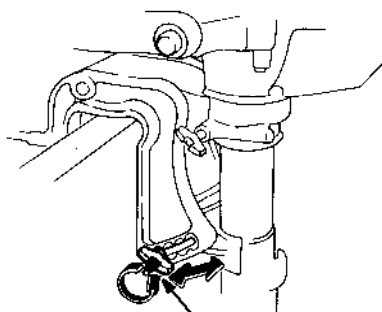

**ADJUSTING ROD
AND WING NUT**

5. PRE-OPERATION CHECK

1. Check the engine oil level.

CAUTION:

- Engine oil is a major factor affecting engine performance and service life. Non-detergent and low quality oils are not recommended.
- Running the engine with insufficient oil can cause serious engine damage.

Use Honda 4-stroke oil, or an equivalent high detergent, premium quality motor oil certified to meet or exceed U.S. automobile manufacturer's requirements for Service Classification SE or SF. (Motor oils classified SE or SF will show this designation on the container.)

Select the appropriate viscosity for the average temperature in your area. SAE 10W-40 is recommended for general, all-temperature use.

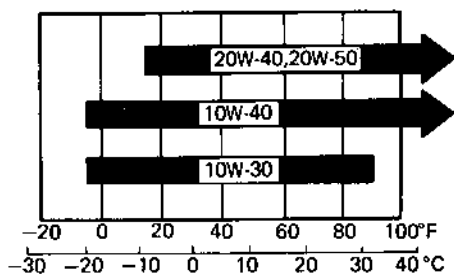

1. Position the outboard motor vertically, and check the oil level in the oil level inspection window.
2. If the oil level is down toward the lower level mark on the window, fill up to the 0.4 ℓ mark on the dipstick.

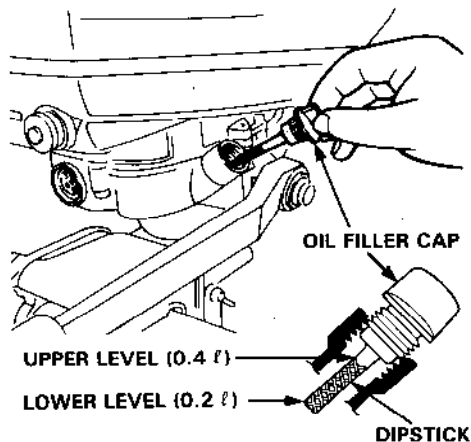
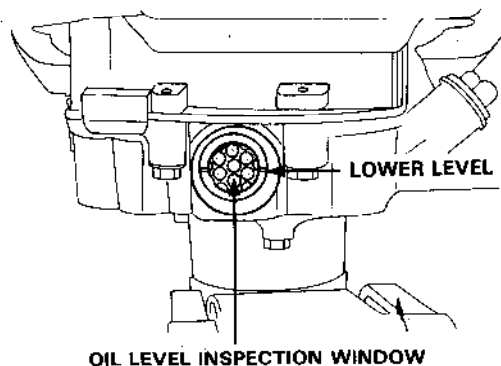

2. Check the fuel level

Use any regular grade automotive gasoline (unleaded gasoline is preferred) with a pump octane rating of 86 or higher. Never use an oil/gasoline mixture or dirty gasoline. Avoid getting dirt, dust or water in the fuel tank.

CAUTION: Gasoline substitutes are not recommended; they may be harmful to the fuel system components.

Fuel tank capacity: 1.0 ℓ (0.26 US gal)

WARNING

- Gasoline is extremely flammable and explosive under certain conditions.
Refuel in a well ventilated area with the engine stopped.
- Do not smoke or allow flames or sparks near the fuel tank.
- Do not overfill the tank and make sure the filler cap is securely closed after refueling.
- Be careful not to spill fuel when refueling. Fuel vapor or spilled fuel may ignite. If any fuel is spilled, make sure the area is dry before starting the engine.

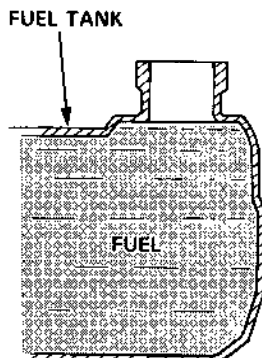
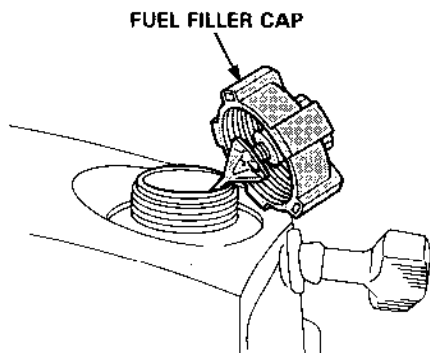

3. Check the following items.

- Check the propeller, the shear pin, and the cotter pin to be sure they are secure and undamaged.
- Check the stern bracket to be sure the motor is securely installed.
- Check steering handle operation.
- Make sure you have the tool kit and spare parts with you (p. 26).

6. STARTING THE ENGINE

1. Open the fuel cap vent knob 2 to 3 turns.

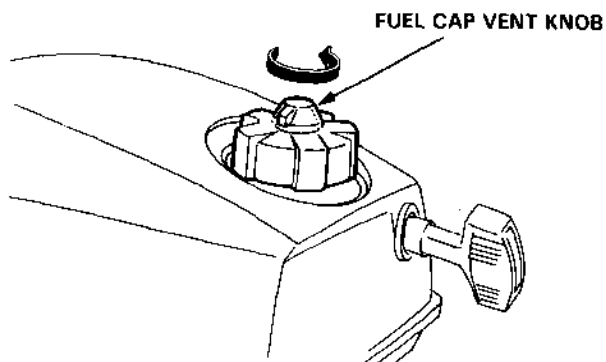

2. Turn the fuel valve lever ON.

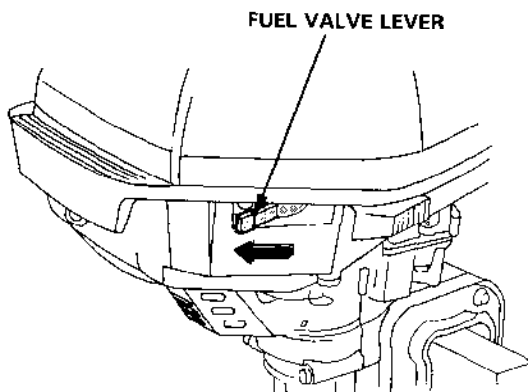

3. Move the throttle lever to the START position.

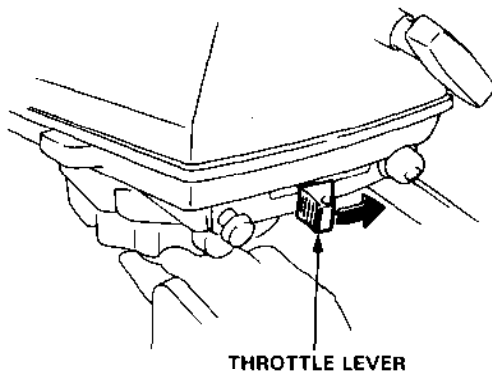

CAUTION: Do not start the engine with the throttle lever in the FAST position, or the boat may move suddenly when the engine starts.

4. In temperatures below 20°C (68° F) use the choke knob.

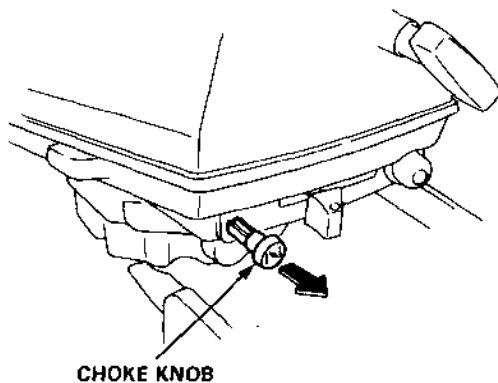

-
5. Pull the starter rope slowly until resistance is felt, then pull briskly.
NOTE: Do not allow the starter grip to snap back. Return it slowly by hand.

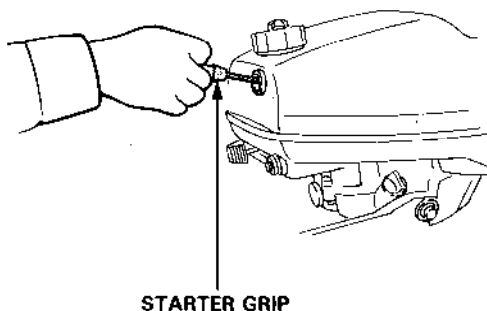

6. After starting, be sure water is flowing out of the water check hole.

CAUTION: If water does not flow out, or if steam comes out, stop the engine. Check to see if the water intake is obstructed. Do not operate the engine until the problem has been corrected.

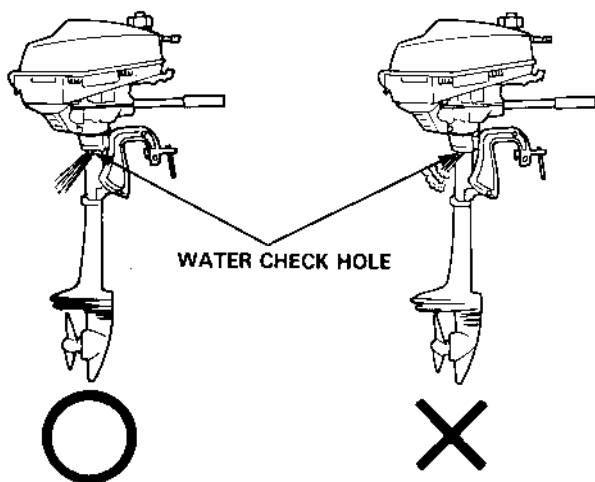

7. If the choke was used, push it in gradually as the engine warms up.

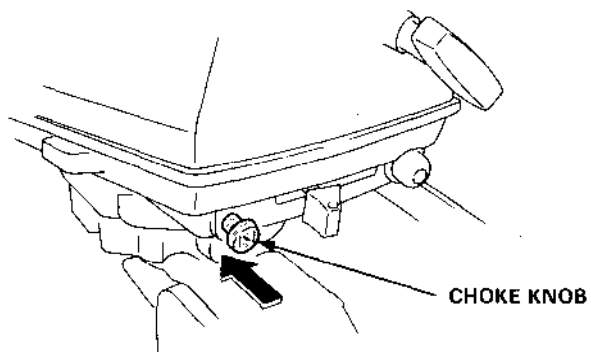

Emergency Starting

If the recoil starter is not working properly, the engine can be started with the spare starter rope in the tool kit.

1. Remove the engine cover.
2. Remove the recoil starter by removing the three 6 mm nuts.
3. Wind the spare rope clockwise around the pulley to start the engine.

CAUTION: Keep clear of moving parts.

4. Reinstall the engine cover.

CAUTION: Do not operate without the engine cover. Exposed moving parts could cause injury and water may damage the engine.

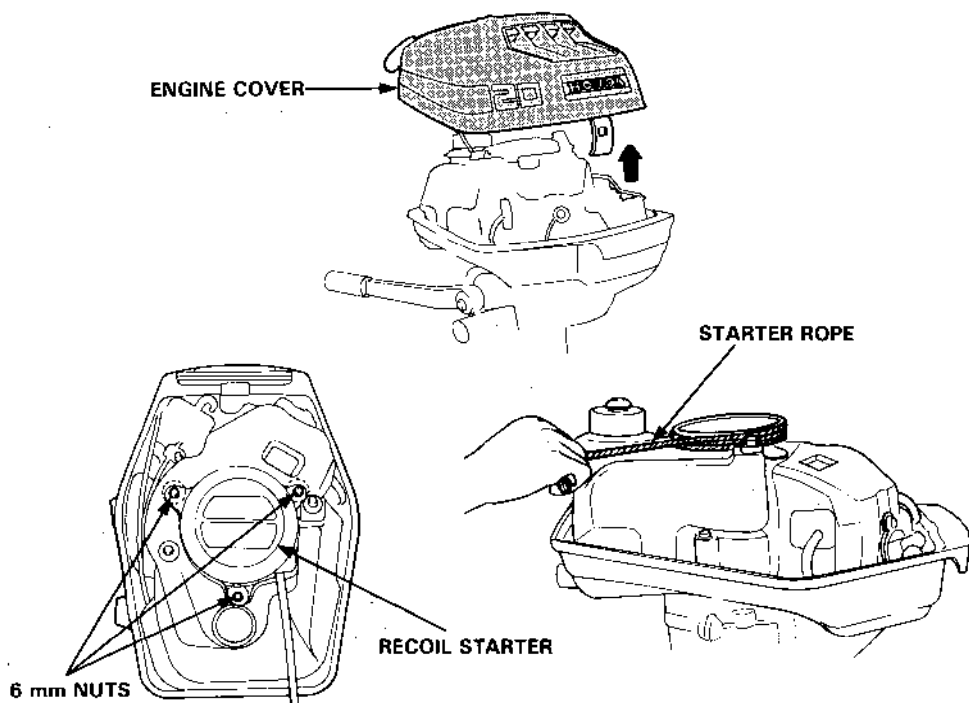

7. OPERATION

1. Cruising

Turn the throttle lever toward **FAST** to increase speed. For normal cruising, open the throttle about $3/4$.

NOTE: For best performance, passengers and equipment should be distributed to balance the boat evenly from side to side and parallel to the water from front to back.

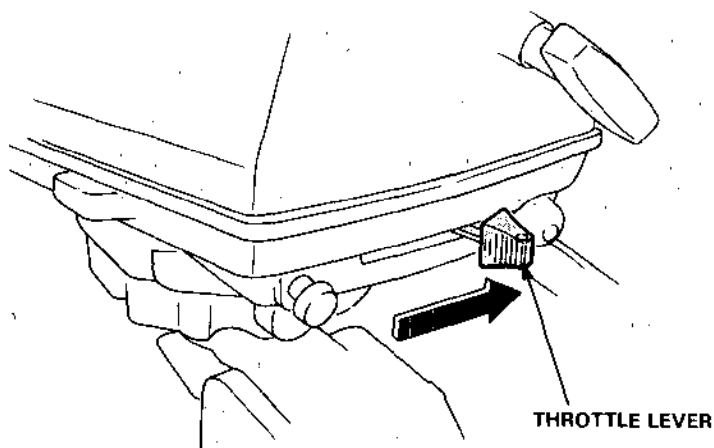

2. Steering

To turn to the right, swing the steering handle to the left. To turn to the left, swing the handle to the right.

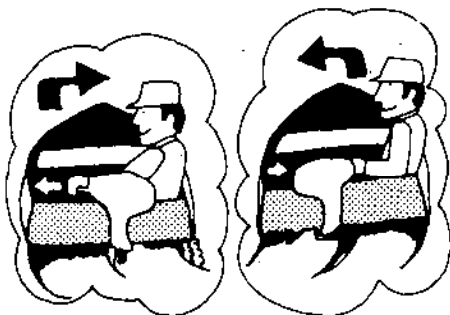

For smooth steering, adjust the steering friction bolt so that a slight drag is felt when turning.

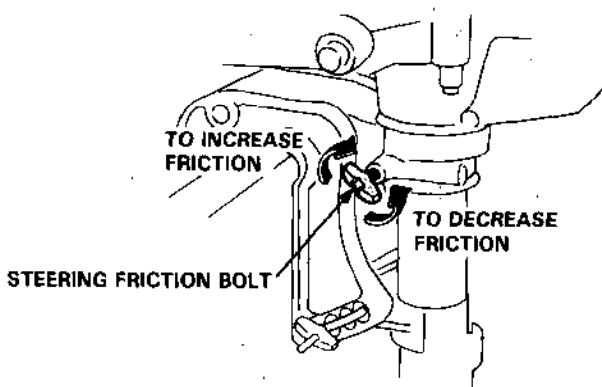

3. Reverse

1. Move the throttle lever to the SLOW position.

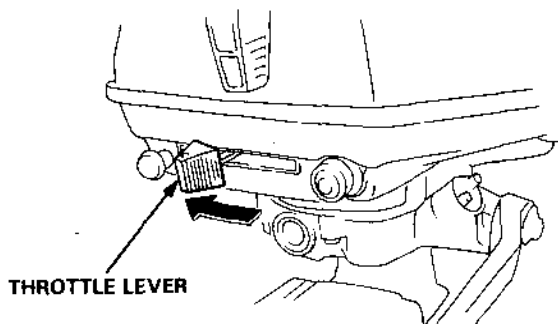

2. Turn the steering handle 180° to reverse the direction of the motor.

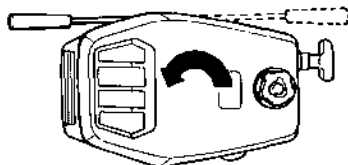

CAUTION: Do not reverse the motor while the throttle lever is beyond the SLOW position, or the boat could overturn.

4. Tilting the Motor

Tilt the motor to prevent the propeller and gear case from hitting bottom when the boat is beached or stopped in shallow water.

1. Stop the engine and turn the fuel valve lever off.
2. Close the fuel cap vent knob.
3. Use the carrying handle to raise the motor. The spring-loaded tilt lever will automatically move into position and hold the motor when it reaches approximately 75°.
4. To return the motor to the normal RUN position, hold the motor by the carrying handle and pull the tilt lever toward you, then lower the motor slowly.

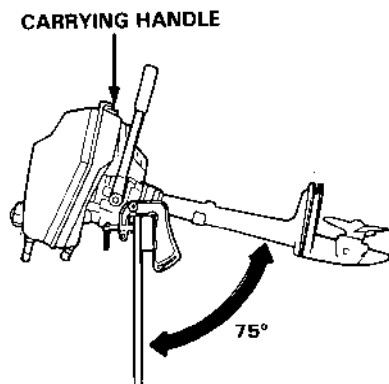
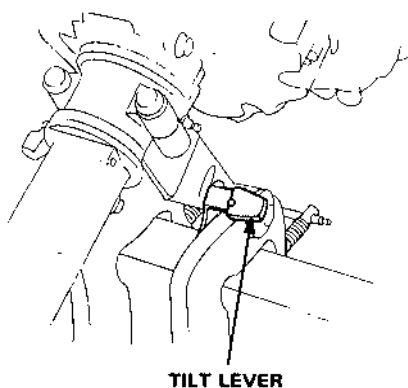

CAUTION: Do not transport the motor in the tilted position; it may drop suddenly causing damage to the boat or the motor.

CAUTION: To avoid damaging the motor, use the utmost care when mooring a boat, especially when its motor is tilted up. Don't allow the motor to strike against the pier or other boats.

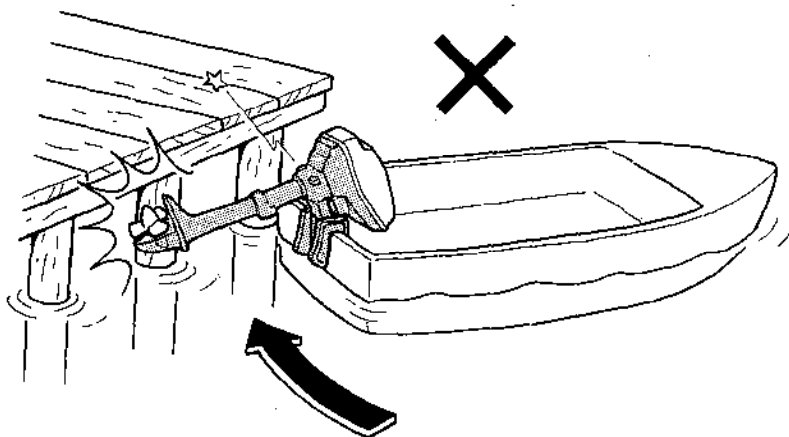

CAUTION: To avoid damaging the motor, never use it as a handle for lifting or moving the boat.

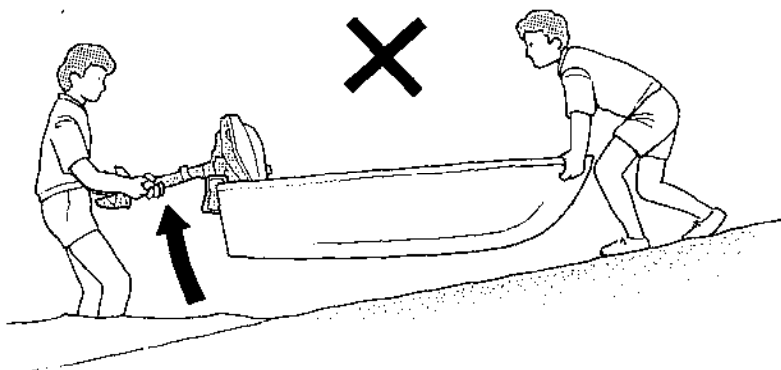

8. STOPPING THE ENGINE

1. Move the throttle lever all the way to the left.

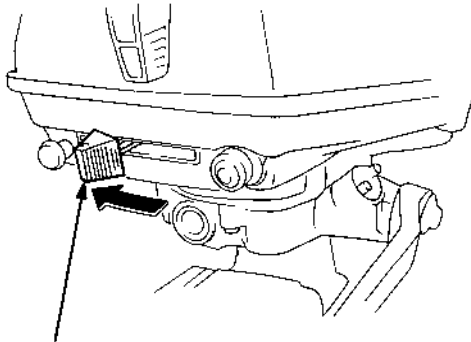

THROTTLE LEVER

2. Push the stop button until the engine stops running.

ENGINE STOP BUTTON

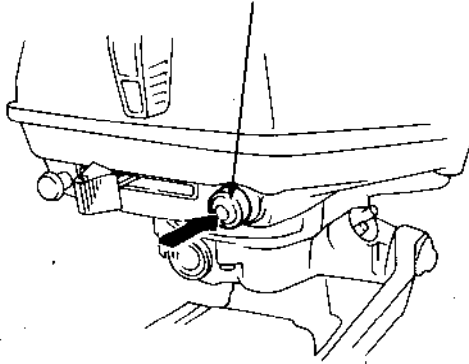

3. Turn the fuel valve lever OFF.

FUEL VALVE LEVER

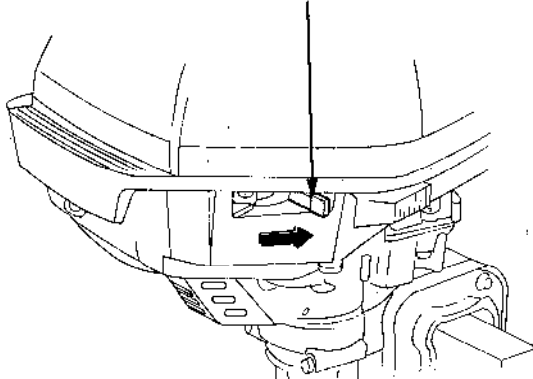

4. Close the fuel cap vent knob.

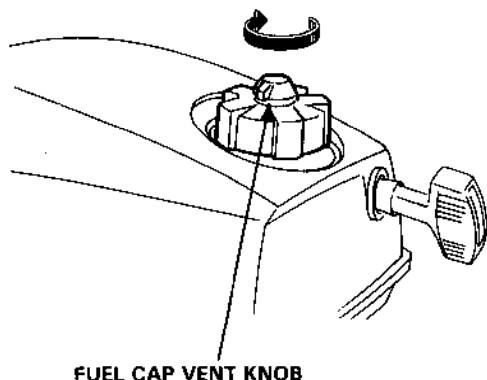

• **High altitude operation**

At high altitude, the standard carburetor air-fuel mixture will be excessively rich. Performance will decrease, and fuel consumption will increase.

High altitude performance can be improved by installing a smaller diameter main fuel jet in the carburetor and readjusting the pilot screw. If you always operate the riding mower at altitudes higher than 6,000 feet above sea level, ask your authorized Honda Outboard Motor dealer perform these carburetor modifications.

Even with suitable carburetor jetting, engine horsepower will decrease approximately 3.5% for each 1,000 foot increase in altitude. The affect of altitude on horsepower will be greater than this if no carburetor modification is made.

CAUTION: Operation of the Outboard Motor at an altitude lower than the carburetor is jetted for may result in reduced performance, overheating, and seious engine damage caused by an excessively lean air/fuel mixture.

9. MAINTENANCE

Periodic maintenance and adjustment are important to keep the motor in the best operating condition. Inspect or service as scheduled below.

WARNING Shut off the engine before performing any maintenance. If the engine must be run, make sure the area is well ventilated. The exhaust contains poisonous carbon monoxide gas.

CAUTION:

- If the engine must be run, make sure there is water at least 4 inches above the anti-cavitation plate, otherwise the water pump may not receive sufficient cooling water, and the extension case will overheat.
- To maintain cooling system efficiency, flush the outboard motor with fresh water after each use in salt water.
- Use only genuine HONDA parts or their equivalent. The use of replacement parts which are not of equivalent quality may damage the motor.

ITEM		Regular Service Period. Perform at every indicated month or operating hour interval, whichever occurs first.			Ref. Page
		First 20 hours or 1 Month	Every 100 hours or 6 Months	Every 200 hours or 1 Year	
ENGINE OIL	CHANGE	○	○		P.27
GEAR CASE OIL	CHANGE	○		○	P.28
GEAR CASE OIL	CHECK FOR WATER contamination	EVERY 50 HOURS			P.28
SPARK PLUG	CLEANING • ADJUST		○		P.29
COMBUSTION CHAMBER AND VALVE	CLEANING	EVERY 300 HOURS (2)			-
VALVE TAPPET CLEARANCE	ADJUSTMENT	○ (2)		○ (2)	-
CARBURETOR LINKAGE	CHECK	○ (2)	○ (2)		-
FUEL FILTER	CHECK			○	-
FUEL TANK	CLEANING			○	-
SHEAR PIN	CHECK		○		P.32
LUBRICATION	GREASE		○ (1)		P.31

NOTE (1): Lubricate more frequently when used in salt water.

(2): These items should be serviced by an authorized Honda dealer, unless the owner has the proper tools and is mechanically proficient. See the Honda Shop Manual.

Tool kit and spare parts

The following tools and spare parts are supplied with the outboard motor for maintenance, adjustment, and emergency repairs.

TOOL KIT

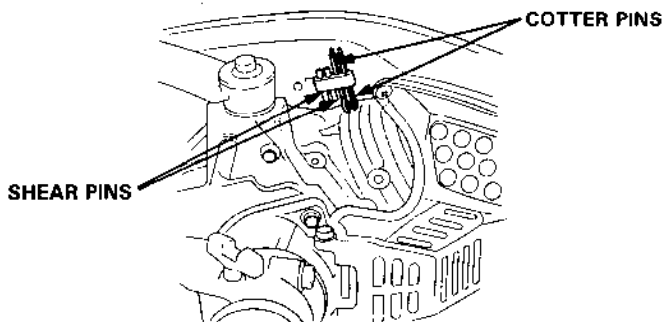
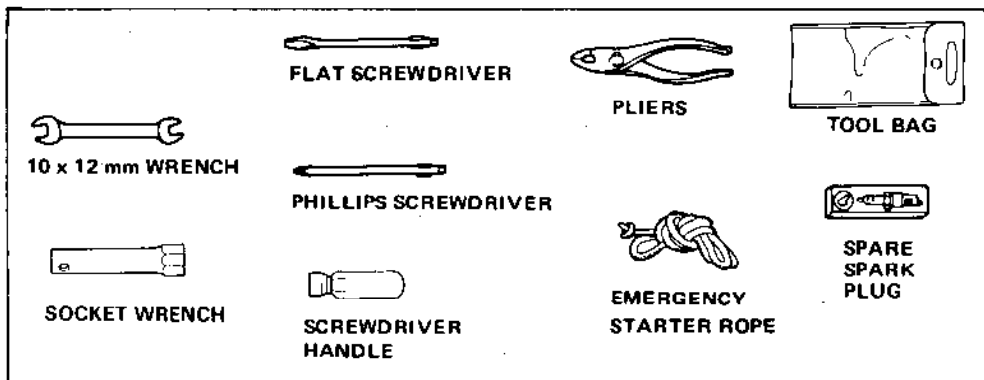

Engine Oil Change

Drain the oil while the engine is still warm to assure rapid and complete draining.

1. Turn the fuel valve lever OFF, and close the fuel cap vent knob.
2. Remove the oil filler cap, and turn the motor on its side to drain the oil.
3. Stand the engine in an upright position, and fill the crankcase with the recommended oil (see p. 10). Check the oil level with the dipstick resting on the filler opening (do not screw in). Fill to the upper level mark on the dipstick.

Oil capacity: 0.4 l (0.42 US qt)

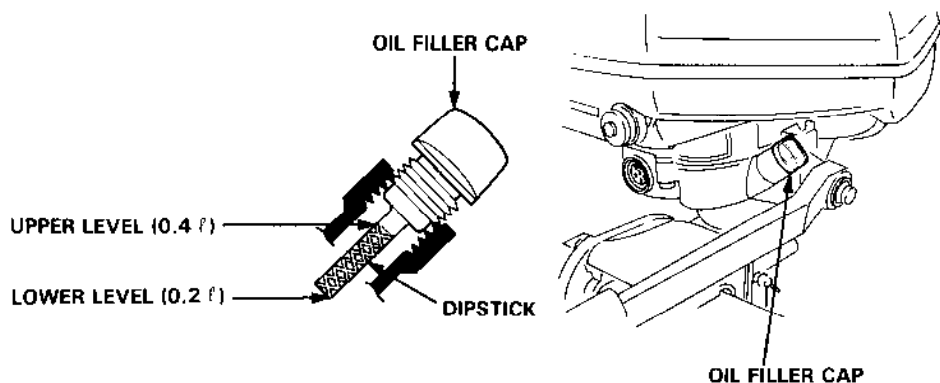

CAUTION: Used motor oil may cause skin cancer if repeatedly left in contact with the skin for prolonged periods. Although this is unlikely unless you handle used oil on a daily basis, it is still advisable to thoroughly wash your hands with soap and water as soon as possible after handling used oil.

NOTE: Please dispose of used motor oil in a manner that is compatible with the environment. We suggest you take it in a sealed container to your local service station for reclamation. Do not throw it in the trash or pour it on the ground.

Gear Oil Check/Change

Oil Level Check

Check the oil level when engine is in the vertical position. Remove the level bolt and see if oil flows out. If no oil comes out, fill through the drain bolt hole until the oil starts to flow out through the level bolt hole. If there is water in the oil, the water will flow out first when the drain bolt is removed, or the oil will be a milky color.

Oil Change

Remove the level bolt and drain bolt to drain the oil. Inject oil through the drain bolt hole until it starts flowing out through the level bolt hole. Reinstall and tighten the level bolt and drain bolt securely.

CAUTION: If water is detected in the oil, the unit should be inspected by an authorized Honda dealer.

Recommended Oil: API standard (GL-4 or GL-5)

SAE 90 outboard motor gear oil

Oil capacity: 0.05 ℓ (0.052 US qt)

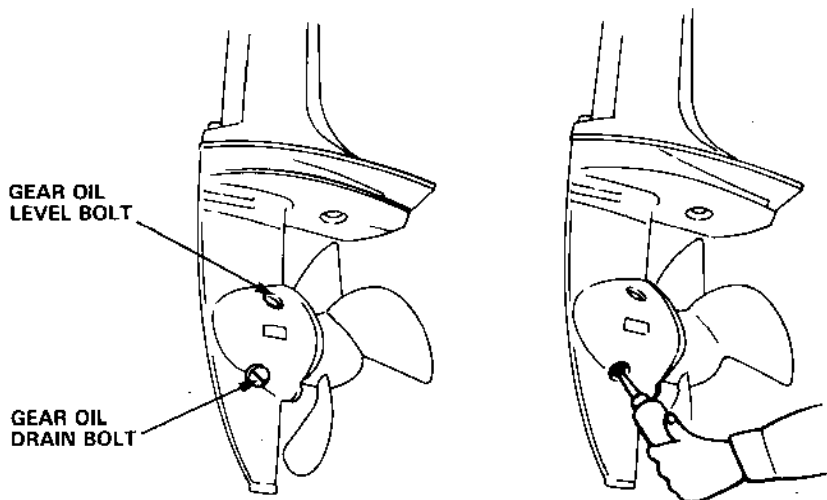

Spark Plug Service

Recommended spark plug: BMR-4A (NGK)

1. Remove the engine cover.
2. Remove the spark plug cap.
3. Use the wrench supplied in the tool kit to remove the spark plug.
4. Visually inspect the spark plug. Discard it if the insulator is cracked or chipped.
5. Measure the plug gap with a feeler gauge.
The gap should be 0.6–0.7 mm (0.024–0.028 in). Correct as necessary by bending the side electrode.
6. Attach the plug washer. Thread the plug in by hand to prevent cross-threading.
7. Tighten a new spark plug 1/2 turn with the wrench to compress the washer. If you are reusing a plug, it should only take 1/8–1/4 turn after the plug seats.
8. Reinstall the engine cover.

CAUTION:

- The spark plug must be securely tightened. An improperly tightened plug can become very hot and possibly damage the engine.
- Never use a spark plug with an improper heat range.

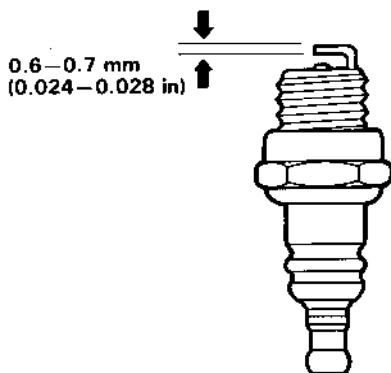
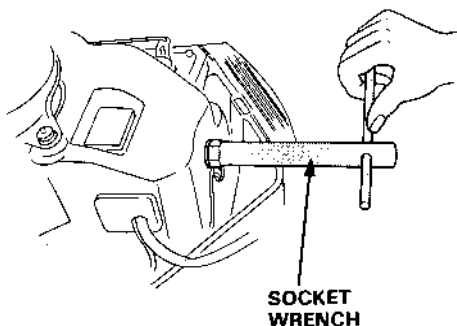

Cleaning and Flushing

After each use in salt water or dirty water, thoroughly clean and flush the outboard motor.

1. Wash the outside of the outboard motor with clean, fresh water.
2. Remove the propeller.
3. Stand the motor in a suitable container of water. The water level must be at least 4 inches above the anti-cavitation plate.
4. Start the engine and run slowly for at least 5 minutes.

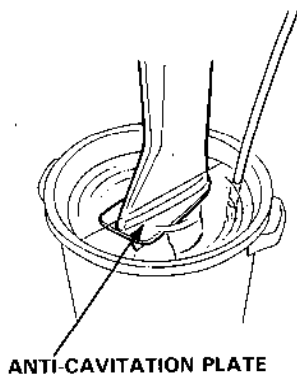

WARNING

- For safety, the propeller must be removed.
- Be sure the outboard motor is securely mounted, and do not leave it unattended while running.

CAUTION: Running the engine without water can cause damage to the extension case due to overheating. Be sure that water flows from the water check hole while the engine is running. If not, stop the engine and determine the cause of the problem.

Lubrication

Wipe the outside of the engine with a cloth dipped in oil. Apply marine anti-corrosion grease to the following parts:

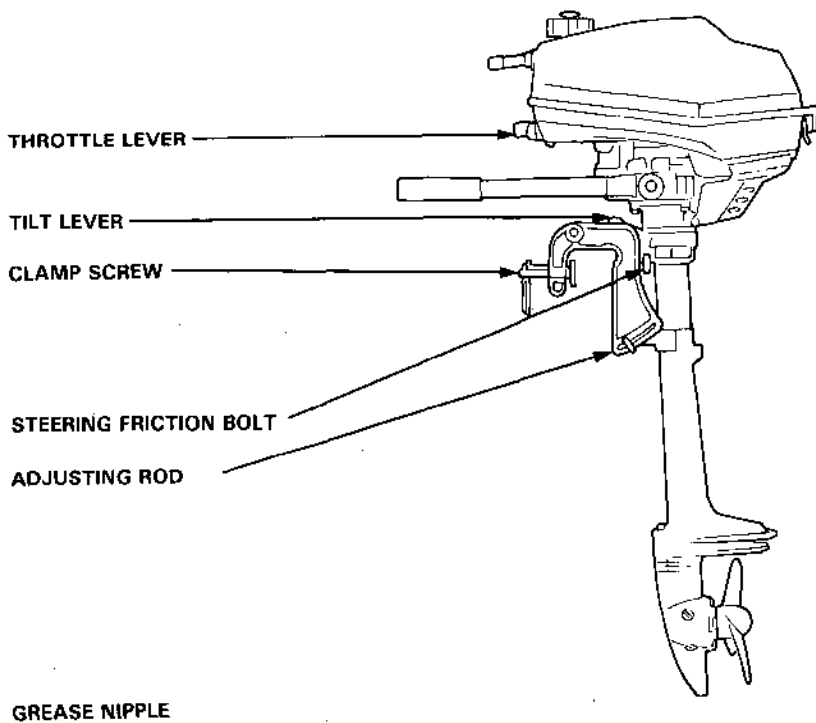

Shear Pin Change

A shear pin is used to protect the propeller and drive mechanism from damage when the propeller strikes an obstruction.

1. Remove the cotter pin and the propeller.
2. Remove the broken shear pin and replace it with a new one.
3. Install the propeller.
4. Install a new cotter pin, and spread the ends as shown in the illustration.

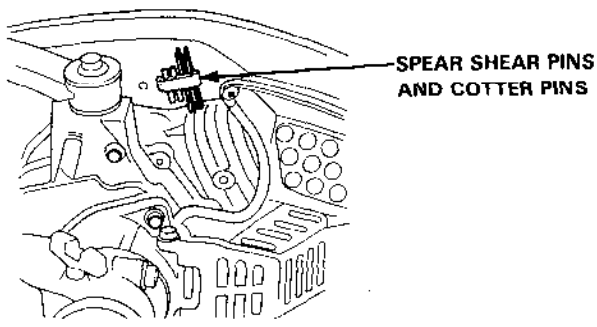
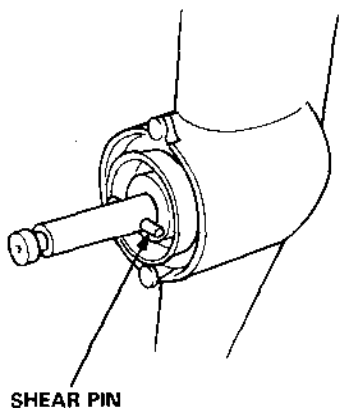
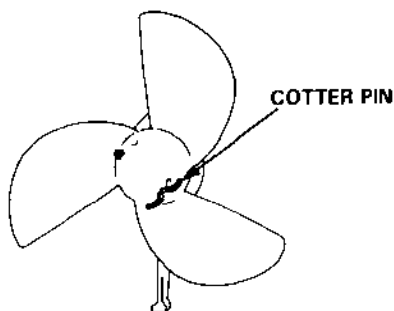

Servicing a Submerged Motor

A submerged motor must be serviced immediately after it is recovered from the water in order to minimize corrosion.

If there is a Honda outboard motor dealership nearby, take the motor immediately to the dealer. If you are far from a dealership, proceed as follows:

1. Remove the engine cover, and rinse the motor with fresh water to remove salt water, sand, mud, etc.
2. Loosen the carburetor drain screw (p. 34), drain the contents of the carburetor into a suitable container, then retighten the drain screw.
3. Change the engine oil (p. 27). If there was water in the engine crankcase, or the used engine oil showed signs of water contamination, then a second engine oil change should be performed after running the engine for 1/2 hour.
4. Remove the spark plug. While pressing the engine stop button, pull the recoil starter several times to completely expel water from the cylinder.

CAUTION:

- **When cranking the engine with an open ignition circuit (spark plug removed from the ignition circuit), keep the engine stop button depressed to prevent electrical damage to the ignition system.**
 - **If the motor was running when it submerged, there may be mechanical damage, such as a bent connecting rod. If the engine binds when cranked, do not attempt to run the motor until it has been repaired.**
5. Pour a teaspoon of engine oil into the spark plug hole, then pull the recoil starter several times to lubricate the inside of the cylinder. Reinstall the spark plug.
 6. Attempt to start the engine. If the engine fails to start, remove the spark plug, clean and dry the electrode, then reinstall the spark plug and attempt to start the engine again. If the engine starts, and no mechanical damage is evident, continue to run the engine for 1/2 hour or longer (be sure the water level is at least 4 inches above the anti-cavitation plate).
 7. As soon as possible, take the motor to a Honda outboard motor dealer for inspection and service.

10. TRANSPORTING /STORAGE

1. Drain the water from the extension case.

While depressing the engine stop button to prevent starting, pull the starter rope several times to expel the water from the extension case.

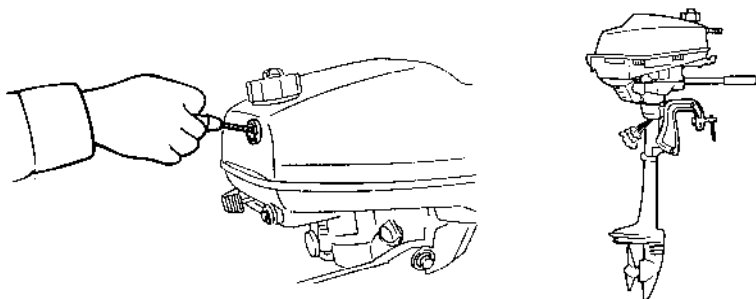

CAUTION:

- Do not rest the motor on its side until the water has been expelled from the extension case, otherwise water will seep into the exhaust system.
- In cold weather, the water must be expelled from the extension case to prevent ice from forming in the water pump and water tube.

2. Drain the fuel

1. Turn the fuel valve lever off.
2. Remove the fuel filler cap and drain the gasoline from the fuel tank into a suitable container.
3. Turn the fuel valve lever on, loosen the carburetor drain screw, and drain the gasoline into a suitable container.
4. After draining, retighten the drain screw.

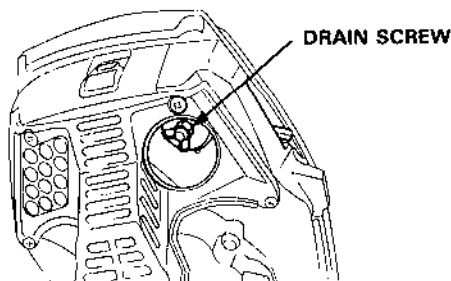

WARNING Fuel vapor or spilled fuel may ignite. Do not smoke or allow flames or sparks in the area where fuel is drained or stored.

3. To carry, hold the motor by the carrying handle.
Do not carry by the engine cover.

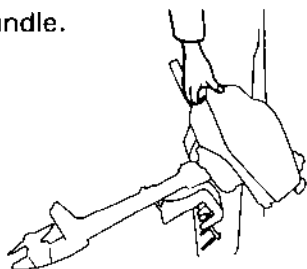

4. Transport and store the motor either vertically or horizontally, as shown here.

Vertical transport or storage: Attach the stern bracket to a stand.

Horizontal transport or storage: Rest the motor on the case protector (the side opposite the steering handle).

CAUTION:

- Any other transport or storage position may cause damage or oil leakage.

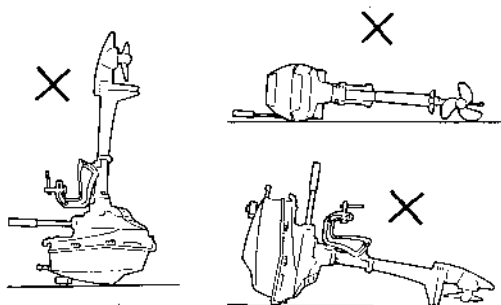
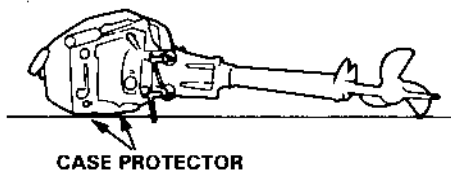
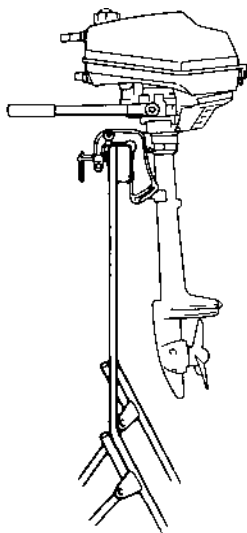

5. Store the outboard motor in a clean, dry area.

NOTE: Before storing, clean, flush, and lubricate the outboard motor as described on pages 30 and 31.

11. TROUBLESHOOTING

Engine Will Not Start:

1. Is there fuel in the fuel tank?
2. Is the fuel cap vent knob turned to ON?
3. Is fuel reaching the carburetor?

Loosen the carburetor drain screw to see if there is fuel in the carburetor float bowl.

 **WARNING** If any fuel is spilled, make sure the area is dry before testing the spark plug or starting the engine. Fuel vapor and spilled fuel may ignite.

4. Is the spark plug firing?
 - a. Remove and inspect the spark plug. Clean and dry the plug, and check the electrode gap (p. 29).
 - b. Install the spark plug in its cap, and ground the side electrode to any engine ground.
 - c. Pull the recoil starter briskly, and see if the plug sparks.
 - d. If the spark plug is OK, reinstall it, and try to start the engine.

Extension Case Overheats:

1. Is the water intake clogged?

12. SPECIFICATIONS

Item	Specification
Output	2.0 horse power (Maximum)
Full throttle range	4,000—5,000 rpm
Engine type	4-stroke side valve one cylinder
Displacement	76 cc (4.7 cu in)
Valve tappet clearance	0.08—0.16 mm (0.003—0.006 in)
Spark plug gap	0.6—0.7 mm(0.024—0.028 in)
Starter system	Recoil starter
Ignition system	Transisterized magneto
Lubrication system	Oil slinger system
Specified oil	Engine: API standard (SE or SF) SAE 10W-40 Gear case: API standard (GL-4/5) SAE 90 outboard motor gear oil
Oil capacity	Engine: 0.4 ℓ (0.42 US qt) Gear case: 0.05 ℓ (0.052 US qt)
Cooling system	Engine: Forced air cooling Exhaust system: Water cooling
Exhaust system	Underwater exhaust
Spark plug	BMR-4A(NGK), W14MR-U(ND)
Fuel	Automotive gasoline (91 research octane, 86 pump octane)
Tank capacity	1.0 ℓ (0.26 US gal)
Steering equipment	Bar handle
Tilt angle	75°
Angle of rotation	360°
Overall length X height X width	S Model 410 × 930 × 275 mm (16.1 × 36.6 × 10.8 in) L Model 410 × 1,080 × 275 mm (16.1 × 42.5 × 10.8 in)
Height from stern bracket to anticavitation plate	S Model 420 mm (16.5 in) L Model 570 mm (22.4 in)
Standard Propeller (No. of blades-diameter X pitch)	3-184 X 120 mm (7-1/4 X 4-23/32 in)
Dry weight	S Model 12.5 kg (27.56 lb) L Model 13.0 kg (28.66 lb)

13. OPTIONAL PARTS

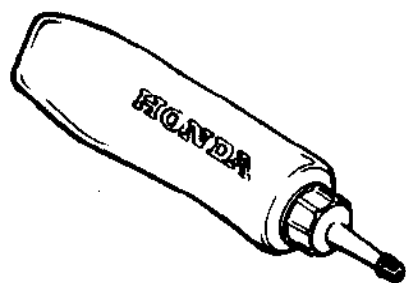

GEAR OIL

14. WARRANTY SERVICE

Owner Satisfaction

Your satisfaction and goodwill are important to your dealer and to us. All Honda warranty details are explained in the Distributor's Limited Warranty. Normally, any problems concerning the product will be handled by your dealer's service department. If you have a warranty problem that has not been handled to your satisfaction, we suggest you take the following action:

- Discuss your problem with a member of dealership management. Often complaints can be quickly resolved at that level. If the problem has already been reviewed with the Service Manager, contact the owner of the dealership or the General Manager.
- If your problem still has not been resolved to your satisfaction, contact the Customer Relations Department of American Honda Motor Co., Inc.

American Honda Motor Co., Inc.
Customer Relations Department
P.O. Box 420
Gardena, California 90247-0842
Telephone: (213) 604-2400

We will need the following information in order to assist you:

- Your name, address, and telephone number
- Product model and serial number
- Date of purchase
- Dealer name and address
- Nature of the problem

After reviewing all the facts involved, you will be advised of what action can be taken. Please bear in mind that your problem will likely be resolved at the dealership, using the dealer's facilities, equipment, and personnel, so it is very important that your initial contact be with the dealer.

Your purchase of a Honda product is greatly appreciated by both your dealer and American Honda Motor Co., Inc. We want to assist you in every way possible to assure your complete satisfaction with your purchase.

Current customer service contact information:

Your owner's manual was written to cover most of the questions you might ask about your Honda. Any questions not answered in the owner's manual can be answered by your Honda dealer. If your dealer doesn't have an immediate answer, they should be able to get it for you.

If you have a difference of opinion with your dealer, please remember that each dealership is independently owned and operated. That's why it's important to work to resolve any differences at the dealership level. If the service personnel are unable to assist you, please discuss your concerns with the dealer management such as the Service Manager or the dealership's owner.

If you need to contact American Honda regarding your experiences with your Honda product or with your dealer, please send your comments to the following address:

American Honda Motor Co., Inc.
Marine Division
Customer Relations Office
4900 Marconi Drive
Alpharetta, GA 30005-8847

Or telephone: (770) 497-6400 M-F, 8:30 am - 7:00 pm EST

When you write or call, please provide the following information:

- Your name, address and telephone number (complete with area code)
- Model and complete serial number
- Date of purchase
- Name and location of the selling dealer
- Name and location of the servicing dealer (if different)
- A detailed description of your concerns

MEMO



HONDA
HONDA MOTOR CO., LTD. TOKYO, JAPAN

31ZV0020
00X31-ZV0-0200

50C8609F
PRINTED IN JAPAN