

MARINE ENGINES

**3JH5E
4JH5E
4JH4-TE
4JH4-HTE1
4JH4-HTE**

- (EN)** English
- (DA)** Danish
- (DE)** German
- (ES)** Spanish
- (FR)** French
- (FI)** Finnish
- (EL)** Greek
- (IT)** Italian
- (NO)** Norwegian
- (NL)** Dutch
- (PT)** Portuguese
- (SV)** Swedish

OPERATION MANUAL	Model	3JH5E, 4JH5E, 4JH4-TE, 4JH4-HTE1, 4JH4-HTE
	Code	0AJHM-M00201

MARINE ENGINES

**3JH5E
4JH5E
4JH4-TE
4JH4-HTE1
4JH4-HTE**

**California
Proposition 65 Warning**

Diesel engine exhaust and some of its constituents are known to the state of California to cause cancer, birth defects, and other reproductive harm.

**California
Proposition 65 Warning**

Battery posts, terminals, and related accessories contain lead and lead compounds, chemicals known to the state of California to cause cancer and reproductive harm.
Wash hands after handling.

Disclaimers:

All information, illustrations and specifications in this manual are based on the latest information available at the time of publishing. The illustrations used in this manual are intended as representative reference views only. Moreover, because of our continuous product improvement policy, we may modify information, illustrations and/or specifications to explain and/or exemplify a product, service or maintenance improvement. We reserve the right to make any change at any time without notice. Yanmar and **YANMAR** are registered trademarks of YANMAR CO., LTD. in Japan, the United States and/or other countries.

All Rights Reserved:

No part of this publication may be reproduced or used in any form by any means - graphic, electronic, or mechanical, including photocopying, recording, taping, or information storage and retrieval systems - without the written permission of YANMAR CO., LTD.

TABLE OF CONTENTS

	Page
INTRODUCTION	1
JH SERIES EMISSION CONTROL SYSTEM WARRANTY-USA, THE ENVIRONMENTAL PROTECTION AGENCY (EPA) ONLY	2
RECORD OF OWNERSHIP	3
SAFETY	5
SAFETY PRECAUTIONS	6
General Information	6
Before You Operate	6
During Operation and Maintenance	6
LOCATION OF SAFETY DECALS	10
PRODUCT OVERVIEW	15
YANMAR JH SERIES FEATURES AND APPLICATIONS	15
New Engine Break-In	16
COMPONENT IDENTIFICATION	17
Right Side (Viewed from Flywheel) - 3JH5E	17
Left Side (Viewed from Flywheel) - 3JH5E	17
Right Side (Viewed from Flywheel) - 4JH5E	18
Left Side (Viewed from Flywheel) - 4JH5E	18
Right Side (Viewed from Flywheel) - 4JH4-TE ..	19
Left Side (Viewed from Flywheel) - 4JH4-TE	19
Right Side (Viewed from Flywheel) - 4JH4-HTE1 / 4JH4-HTE	20
Left Side (Viewed from Flywheel) - 4JH4-HTE1 / 4JH4-HTE	20
NAMEPLATES	21
FUNCTION OF MAJOR COMPONENTS	22

TABLE OF CONTENTS

CONTROL EQUIPMENT	23
Instrument Panel (Optional)	23
Single-Lever Remote Control Handle	31
BEFORE YOU OPERATE	33
INTRODUCTION	33
SAFETY PRECAUTIONS	33
DIESEL FUEL	34
Diesel Fuel Specifications	34
Filling the Fuel Tank	37
Bleeding the Fuel System	38
ENGINE OIL	39
Engine Oil Specifications	39
Engine Oil Viscosity	40
Checking the Engine Oil	40
Adding Engine Oil	40
MARINE GEAR OR SAIL DRIVE OIL	41
Marine Gear Oil Specifications	41
Sail Drive Oil Specifications	41
Checking Marine Gear Oil	41
Adding Marine Gear Oil	42
Checking and Adding Sail Drive Oil	42
ENGINE COOLANT	42
Engine Coolant Specifications	42
Coolant (Closed Cooling System)	43
Checking and Adding Coolant	43
CRANKING THE ENGINE	47
ENGINE OPERATION	49
INTRODUCTION	49
SAFETY PRECAUTIONS	49
STARTING THE ENGINE	51
If the Engine Fails to Start	52
Starting at Low Temperatures	52
After the Engine has Started	53
REMOTE CONTROL HANDLE OPERATION	54
Acceleration and Deceleration	54
Shifting the Engine	54
Switching to Trolling (KMH4A Only)	54
CAUTIONS DURING OPERATION	55

SHUTTING DOWN THE ENGINE	57
Normal Shutdown	57
Emergency Shutdown	58
CHECKING THE ENGINE AFTER OPERATION	58
PERIODIC MAINTENANCE	59
INTRODUCTION.....	59
SAFETY PRECAUTIONS	59
PRECAUTIONS	61
The Importance of Periodic Maintenance	61
Performing Periodic Maintenance	61
The Importance of Daily Checks	61
Keep a Log of Engine Hours and Daily Checks	61
Yanmar Replacement Parts	61
Tools Required	61
Ask Your Authorized Yanmar Marine Dealer or Distributor for Help	61
EPA MAINTENANCE REQUIREMENTS	63
EPA Requirements for USA and Other Applicable Countries.....	63
EPA Requirements	63
Installation of Exhaust Sampling Port	65
PERIODIC MAINTENANCE SCHEDULE	66
PERIODIC MAINTENANCE PROCEDURES	70
Daily Checks.....	70
After Initial 50 Hours of Operation	71
Every 50 Hours of Operation	76
Every 250 Hours of Operation	79
Every 500 Hours of Operation	87
Every 1000 Hours of Operation	87
TROUBLESHOOTING	89
SAFETY PRECAUTIONS	89
TROUBLESHOOTING AFTER STARTING	89
TROUBLESHOOTING INFORMATION.....	90
TROUBLESHOOTING CHART.....	91
LONG-TERM STORAGE	93
PREPARE ENGINE FOR LONG-TERM STORAGE	93
DRAIN SEAWATER COOLING SYSTEM	94
RETURNING THE ENGINE TO SERVICE	96

TABLE OF CONTENTS

SPECIFICATIONS	97
PRINCIPAL ENGINE SPECIFICATIONS	97
3JH5E Engine	98
3JH5E Marine Gears.....	99
4JH5E Engine	100
4JH5E Marine Gear or Sail Drive	102
4JH4-TE Engine	103
4JH4-HTE1 Engine	104
4JH4-HTE Engine	105
4JH4-TE, 4JH4-HTE1 and 4JH4-HTE Marine Gear or Sail Drive	106
SYSTEM DIAGRAMS	107
PIPING DIAGRAMS	107
WIRING DIAGRAMS	137
EPA WARRANTY USA ONLY	149
YANMAR CO., LTD. LIMITED EMISSION CONTROL SYSTEM WARRANTY - USA ONLY	149
Your Warranty Rights and Obligations:	150
Warranty Period:	150
Warranty Coverage:	151
Exclusions:	151
Owner's Responsibility:	151
Customer Assistance:	151
EMISSION SYSTEM WARRANTY	153
NON-ROAD EMISSION SYSTEM WARRANTY	153
Yanmar Co., Ltd. Limited Emission Control System Warranty - USA Only.....	153
Maintenance Log.....	156

INTRODUCTION

Welcome to the world of Yanmar Marine! Yanmar Marine offers engines, drive systems and accessories for all types of boats, from runabouts to sailboats, and from cruisers to mega yachts. In marine leisure boating, the worldwide reputation of Yanmar Marine is second to none. We design our engines to respect nature. This means quieter engines, with minimal vibrations, cleaner than ever. All of our engines meet applicable regulations, including emissions, at the time of manufacture.

To help you enjoy your Yanmar JH series engine for many years to come, please follow these recommendations:

- Read and understand this *Operation Manual* before you operate the machine to ensure that you follow safe operating practices and maintenance procedures.
- Keep this *Operation Manual* in a convenient place for easy access.
- If this *Operation Manual* is lost or damaged, order a new one from your authorized Yanmar Marine dealer or distributor.
- Make sure this manual is transferred to subsequent owners. This manual should be considered a permanent part of the engine and remain with it.
- Constant efforts are made to improve the quality and performance of Yanmar products, so some details included in this *Operation Manual* may differ slightly from your engine. If you have any questions about these differences, please contact your authorized Yanmar Marine dealer or distributor.
- The specifications and components (instrument panel, fuel tank, etc.) described in this manual may differ from ones installed on your vessel. Please refer to the manual provided by the manufacturer of these components.
- Refer to the Yanmar Limited Warranty Handbook for a complete warranty description.

INTRODUCTION

JH SERIES EMISSION CONTROL SYSTEM WARRANTY-USA, THE ENVIRONMENTAL PROTECTION AGENCY (EPA) ONLY

JH series engines come with an emission control system warranty. In all states, 2009 and later compression-ignition engines must be designed, built and equipped to meet the United States EPA emissions standards. Yanmar warrants the emission control system on your JH series engine for the periods of time listed below.

Emission Control Certification			
Model Year	2011	2012	2013
3JH5E	EPA marine CI Tier 3 (Non-road Tier 2)		
4JH5E / 4JH4-TE	EPA marine CI Tier 3 intermediate		
4JH4-HTE1	-	EPA marine CI Tier 3 intermediate	
4JH4-HTE	EPA marine CI Tier 2	-	

Note: *Since 2012, the 4JH4-HTE does not comply with the EPA regulation.*

RECORD OF OWNERSHIP

Take a few moments to record the information you need when you contact Yanmar for service, parts or literature.

Engine Model: _____

Engine Serial No.: _____

Date Purchased: _____

Dealer: _____

Dealer Phone: _____

This Page Intentionally Left Blank

SAFETY

Yanmar considers safety of great importance and recommends that anyone that comes into close contact with its products, such as those who install, operate, maintain or service Yanmar products, exercise care, common sense and comply with the safety information in this manual and on the machine's safety decals. Keep the labels from becoming dirty or torn and replace them if they are lost or damaged. Also, if you need to replace a part that has a label attached to it, make sure you order the new part and label at the same time.



This safety alert symbol appears with most safety statements. It means attention, become alert, your safety is involved! Please read and abide by the message that follows the safety alert symbol.

DANGER

Indicates a hazardous situation which, if not avoided, *will* result in death or serious injury.

WARNING

Indicates a hazardous situation which, if not avoided, *could* result in death or serious injury.

CAUTION

Indicates a hazardous situation which, if not avoided, *could* result in minor or moderate injury.

NOTICE

Indicates a situation which can cause damage to the machine, personal property and / or the environment, or cause the equipment to operate improperly.

SAFETY PRECAUTIONS

General Information

There is no substitute for common sense and careful practices. Improper practices or carelessness can cause burns, cuts, mutilation, asphyxiation, other bodily injury or death. This information contains general safety precautions and guidelines that must be followed to reduce risk to personal safety. Special safety precautions are listed in specific procedures. Read and understand all of the safety precautions before operation or performing repairs or maintenance.

Before You Operate

DANGER

The safety messages that follow have DANGER level hazards.



NEVER permit anyone to install or operate the engine without proper training.

Read and understand this *Operation Manual* before you operate or service the engine to ensure that you follow safe operating practices and maintenance procedures.

- Safety signs and labels are additional reminders for safe operating and maintenance techniques.
- See your authorized Yanmar Marine dealer or distributor for additional training.

During Operation and Maintenance

WARNING

The safety messages that follow have WARNING level hazards.

Explosion Hazard



While the engine is running or the battery is charging, hydrogen gas is being produced and can be easily ignited. Keep the area around the battery

well-ventilated and keep sparks, open flames and any other form of ignition out of the area.

Fire and Explosion Hazard

Diesel fuel is flammable and explosive under certain conditions.

NEVER use a shop rag to catch the fuel.

Wipe up all spills immediately.

NEVER refuel with the engine running.

Fire Hazard



Undersized wiring systems can cause an electrical fire.

Store any containers containing fuel or other flammable products in a well-ventilated area, away from any combustibles or source of ignition.

Store any equipment in a designated area away from moving parts.

NEVER use the engine compartment for storage.

⚠ WARNING**Sever Hazard**

Rotating parts can cause severe injury or death. NEVER wear jewelry, unbuttoned cuffs, ties or loose-fitting clothing and

ALWAYS tie long hair back when working near moving / rotating parts such as the flywheel or PTO shaft. Keep hands, feet and tools away from all moving parts.

Alcohol and Drug Hazard

NEVER operate the engine while under the influence of alcohol or drugs, or when feeling ill.

Exposure Hazard

ALWAYS wear personal protective equipment including appropriate clothing, gloves, work

shoes, and eye and hearing protection as required by the task at hand.

Sudden Movement Hazard

NEVER operate the engine while wearing a headset to listen to music or radio because it will be difficult to hear the warning signals.

Burn Hazard

Some of the engine surfaces become very hot during operation and shortly after shutdown.

Keep hands and other body parts away from hot engine surfaces.

Exhaust Hazard

NEVER block windows, vents or other means of ventilation if the engine is operating in an enclosed area. All internal combustion engines create carbon monoxide gas during operation and special precautions are required to avoid carbon monoxide poisoning.

CAUTION

The safety messages that follow have CAUTION level hazards.

Poor Lighting Hazard

Ensure that the work area is adequately illuminated. ALWAYS install wire cages on portable safety lamps.

Tool Hazard

ALWAYS use tools appropriate for the task at hand and use the correct size tool for loosening or tightening machine parts.

Flying Object Hazard

ALWAYS wear eye protection when servicing the engine or when using compressed air or high-pressure water. Dust, flying debris, compressed air, pressurized water or steam may injure your eyes.

Coolant Hazard



Wear eye protection and rubber gloves when you handle engine coolant. If contact with the eyes or skin should occur, flush eyes and wash immediately with clean water.

NOTICE

The safety messages that follow have NOTICE level hazards.

It is important to perform daily checks as listed in the *Operation Manual*. Periodic maintenance prevents unexpected downtime, reduces the number of accidents due to poor engine performance and helps extend the life of the engine.

See your authorized Yanmar Marine dealer or distributor if you need to operate the engine at high altitudes. At high altitudes the engine will lose power, run rough and produce exhaust gases that exceed the design specifications.



ALWAYS be environmentally responsible.

Follow the guidelines of the EPA or other governmental agencies for the proper disposal of hazardous materials such as engine oil, diesel fuel and engine coolant. Consult the local authorities or reclamation facility.

NEVER dispose of hazardous materials by dumping them into a sewer, on the ground, or into ground water or waterways.

If a Yanmar Marine Engine is installed at an angle that exceeds the specifications stated in the Yanmar Marine *Installation Manuals*, engine oil may enter the combustion chamber causing excessive engine speed, white exhaust smoke and serious engine damage. This applies to engines that run continuously or those that run for short periods of time.

NOTICE

If you have an installation with two or three engines and only one engine is operating, the water pickup (thru-hull) of the non-running engine(s) should be closed. This will prevent water from being forced past the seawater pump and eventually finding its way into the engine. The result of water entering the engine could cause seizure or other serious problems.

If you have an installation with two or three engines, and only one engine is operating, please note that if the propeller shaft thru-hull (stuffing box) is lubricated by engine water pressure and the engines are interconnected, care must be taken that water from the running engine does not enter the exhaust of the non-running engine(s). This water could cause seizure of the non-running engine(s). See your authorized Yanmar Marine dealer or distributor for a complete explanation of this condition.

If you have an installation with two or three engines, and only one engine is operating, it is important to limit the amount of throttle applied to the running engine. If you observe black smoke or movement of the throttle does not increase engine speed, you are overloading the engine that is running. Immediately throttle back to approximately 2/3 throttle or to a setting where the engine performs normally. Failure to do so may cause the running engine to overheat or cause excess carbon buildup which may shorten the engine's life.

NEVER turn off the battery switch (if equipped) or short the battery cables during operation. Damage to the electrical system will result.

LOCATION OF SAFETY DECALS

Figure 1, Figure 2, Figure 3 and Figure 4 show the location of safety decals on Yanmar JH series marine engines.

3JH5E Engines

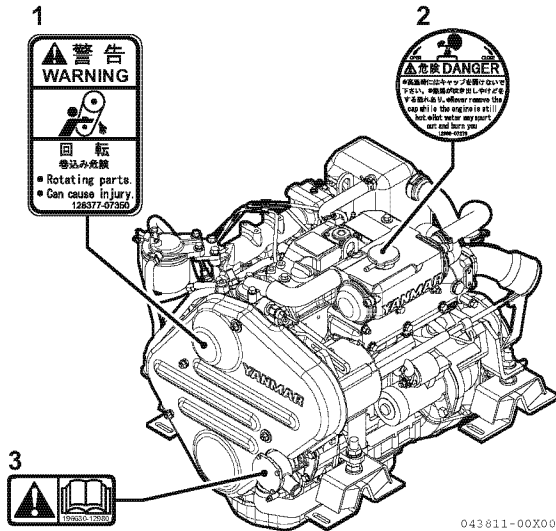

Figure 1

- 1-Part Number: 128377-07350
- 2-Part Number: 128990-07270
- 3-Part Number: 196630-12980

4JH5E Engines

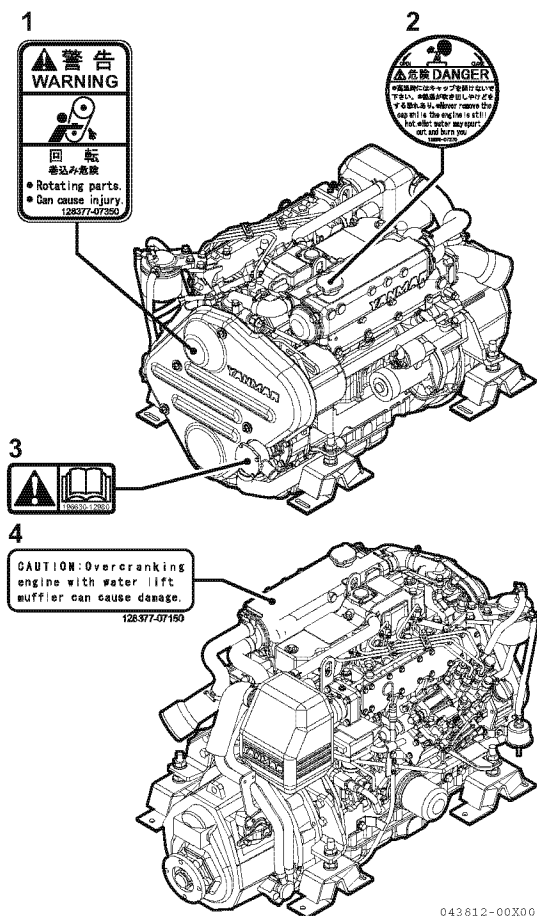

Figure 2

1-Part Number: 128377-07350

2-Part Number: 128990-07270

3-Part Number: 196630-12980

4-Part Number: 128377-07150

4JH4-TE Engines

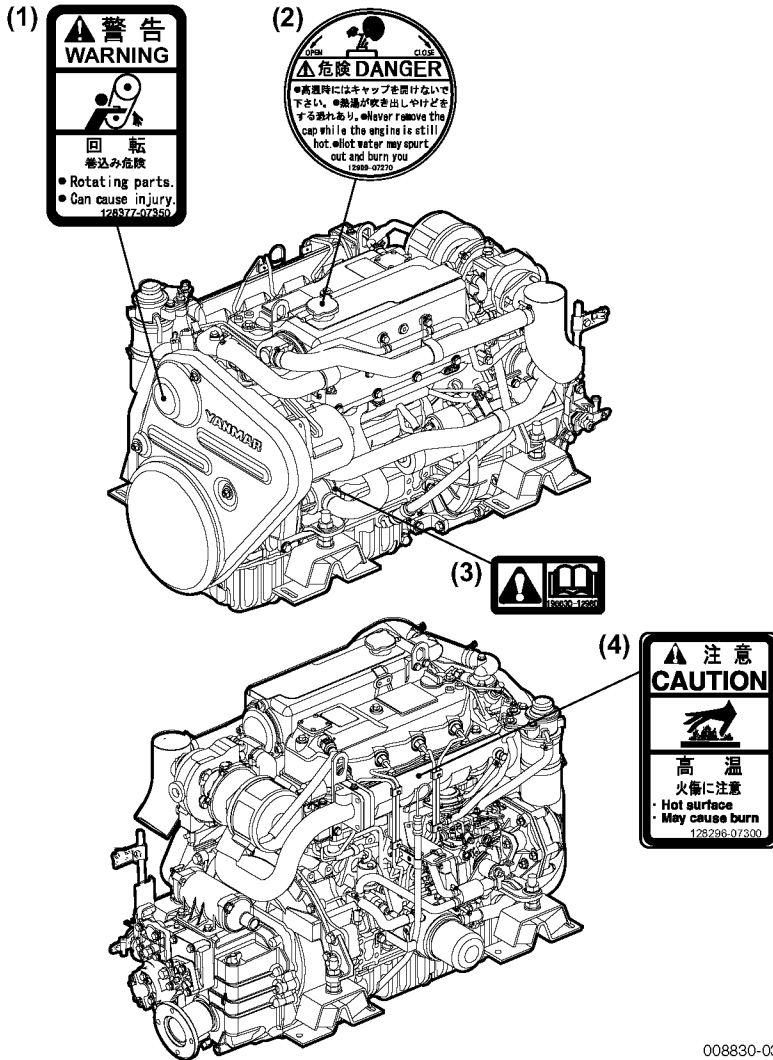

008830-03X

Figure 3

1-Part Number: 128377-07350

2-Part Number: 128990-07270

3-Part Number: 196630-12980

4-Part Number: 128296-07300

4JH4-HTE1 / 4JH4-HTE Engines

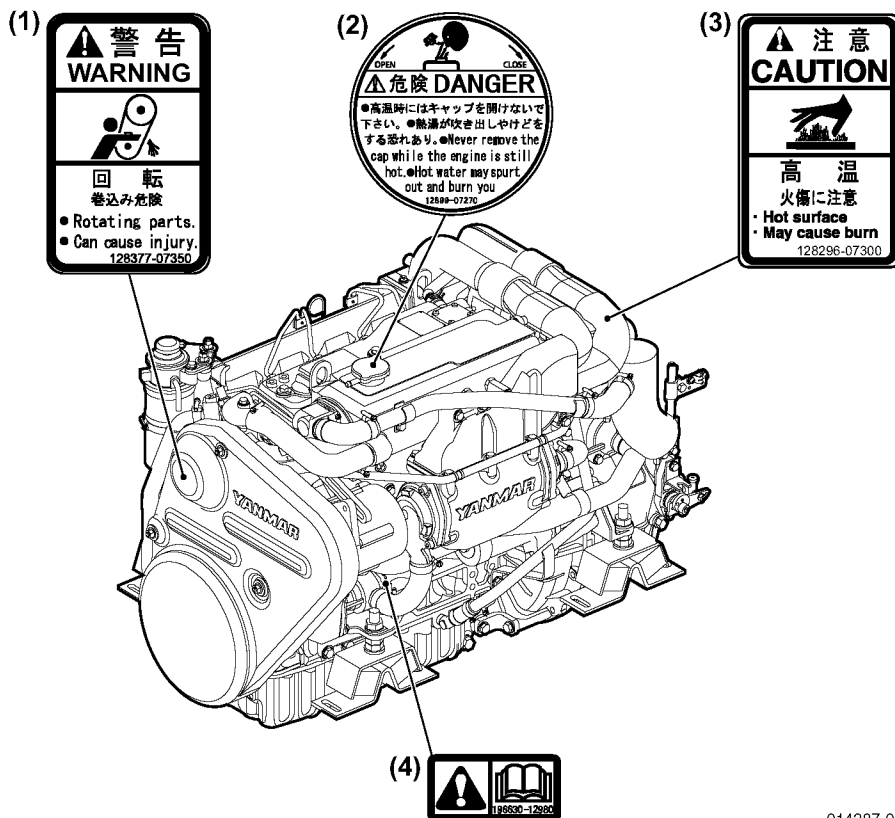

014387-01X

Figure 4

1-Part Number: 128377-07350

2-Part Number: 128990-07270

3-Part Number: 128296-07300

4-Part Number: 196630-12980

This Page Intentionally Left Blank

PRODUCT OVERVIEW

YANMAR JH SERIES FEATURES AND APPLICATIONS

The JH series are four-stroke direct injection diesel engines equipped with liquid coolant systems.

The 3JH5E is 3-cylinder and naturally aspirated.

The 4JH5E is 4-cylinder and naturally aspirated.

The 4JH4-TE is 4-cylinder and turbocharged.

The 4JH4-HTE1, 4JH4-HTE is 4-cylinder and turbocharged with an intercooler.

The engines are equipped with a marine gear or sail drive unit.

These engines are designed for pleasure craft use.

It is recommended that new vessels be propped so the engines can operate at 100 to 200 min⁻¹ above the fuel stop power engine speed to allow for some added weight and hull resistance.

Failure to do so can lead to reduced vessel performance, lead to increased smoke levels and cause permanent damage to your engine.

The engine must be installed correctly with coolant lines, exhaust gas lines and electrical wiring. Any auxiliary equipment attached to the engine should be easy to use and accessible for service. To handle the drive equipment, propulsion systems (including the propeller) and other inboard equipment, always observe the instructions and cautions given in the operation manuals supplied by the shipyard and equipment manufacturers.

The JH series engines are designed to be operated at maximum throttle (3000 to 3200 min⁻¹) for less than 5% of total engine time (30 minutes out of every 10 hours) and cruising speed (2800 min⁻¹ or less) for less than 90% of total engine time (9 hours out of every 10 hours).

The laws of some countries may require hull and engine inspections, depending on the use, size and cruising area of the boat. The installation, fitting and surveying of this engine all require specialized knowledge and engineering skills. See Yanmars local subsidiary in your region or your authorized Yanmar Marine dealer or distributor.

PRODUCT OVERVIEW

New Engine Break-In

As with all reciprocating engines, the way your engine is operated during its first 50 hours of operation plays a very significant role in determining how long it will last and how well the engine will perform over its lifetime.

A new Yanmar diesel engine must be operated at suitable speeds and power settings during the break-in period to make the sliding parts, such as piston rings, break-in properly and to stabilize engine combustion.

During the break-in period, the engine coolant temperature gauge should be monitored; temperature should be between 71° and 87°C (160° and 190°F).

During the first 10 hours of operation, the engine should be run at maximum engine speed minus 400 to 500 min⁻¹ (approximately 60 to 70% of load) most of the time. This will ensure the sliding parts break in properly. During this period, avoid operating at maximum engine speed and load to avoid damaging or scoring sliding parts.

NOTICE

Do not operate at WOT (wide open throttle) for more than a minute at a time during the first 10 hours of operation.

Do not operate the engine at low idle or at low speed and light load for more than 30 minutes at a time. Since unburned fuel and engine oil will adhere to the piston rings when operating at low speeds for long periods, this will interfere with proper movement of the rings and the engine oil consumption may increase. Low idle speed does not allow break-in of sliding parts.

If operating engine at low speed and light load, you must race the engine to clean the carbon from the cylinders and fuel injection valve.

Perform this procedure in open waters:

- With the clutch in NEUTRAL, accelerate from the low-speed position to the high-speed position briefly.
- Repeat this process five times.

Once past the initial 10 hours until 50 hours, the engine should be used over its full operating range, with special emphasis on running at relatively high power settings. This is not the time for an extended cruise at idle or low speed. The boat should be run at maximum speed minus 400 min⁻¹ most of the time (approximately 70% load), with a 10 minute run at maximum minus 200 min⁻¹ (approximately 80% load) every 30 minutes and a 4 to 5 minute period of operation at WOT (wide open throttle) once each 30 minutes. During this period, be sure not to operate your engine at low speed and light load for more than 30 minutes. If operating engine at low speed and light load by necessity, just after the low idle operation, be sure to race the engine.

To complete engine break-in, perform *After Initial 50 Hours of Operation* maintenance procedures. After Initial 50 Hours of Operation on page 71.

COMPONENT IDENTIFICATION

Right Side (Viewed from Flywheel) - 3JH5E

Figure 1 and Figure 2 illustrate a typical version of a 3JH5E engine. Your engine may have different equipment from that illustrated.

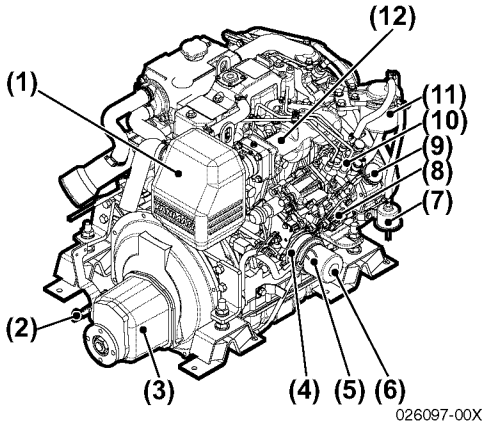

Figure 1

- 1 – Intake Silencer (air cleaner)
- 2 – Shift Lever
- 3 – Marine Gear
- 4 – Oil Cooler
- 5 – Engine Oil Dipstick
- 6 – Engine Oil Filter
- 7 – Electric Fuel Priming Pump
- 8 – Fuel Feed Pump
- 9 – Engine Oil Filler Cap
- 10 – Fuel Injection Pump
- 11 – Fuel Filter
- 12 – Intake Manifold

Left Side (Viewed from Flywheel) - 3JH5E

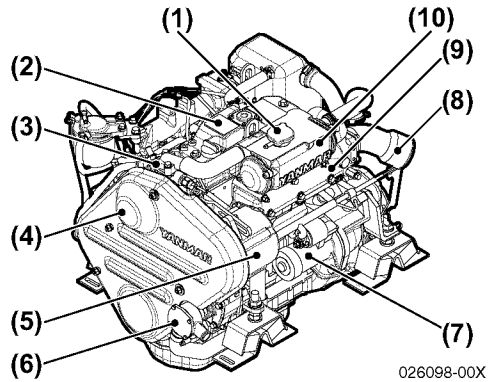

Figure 2

- 1 – Coolant Filler Cap
- 2 – Engine Nameplate (on rocker arm cover)
- 3 – Coolant Pump
- 4 – Belt Cover
- 5 – Alternator
- 6 – Seawater Pump
- 7 – Starter Motor
- 8 – Mixing Elbow
- 9 – Exhaust Manifold
- 10 – Coolant Tank / Heat Exchanger

PRODUCT OVERVIEW

Right Side (Viewed from Flywheel) - 4JH5E

Figure 3 and Figure 4 illustrate a typical version of a 4JH5E engine. Your engine may have different equipment from that illustrated.

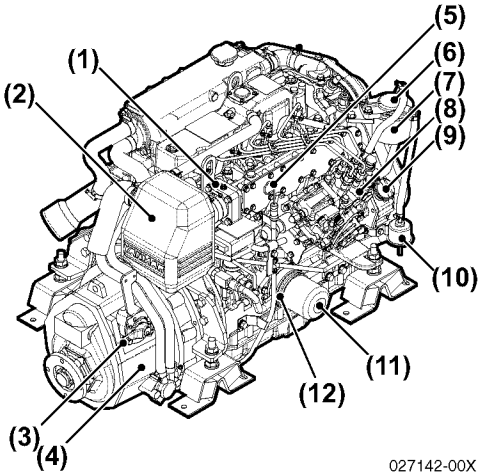

Figure 3

- 1 – Air Heater
- 2 – Intake Silencer
- 3 – Shift Lever
- 4 – Marine Gear
- 5 – Engine Oil Dipstick
- 6 – Header (fuel filter)
- 7 – Fuel Filter
- 8 – Fuel Injection Pump
- 9 – Engine Oil Filler Cap
- 10 – Electric Fuel Feed Pump
- 11 – Engine Oil Filter
- 12 – Oil Cooler

Left Side (Viewed from Flywheel) - 4JH5E

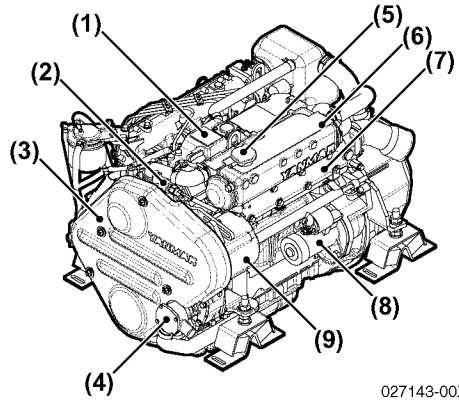

Figure 4

- 1 – Engine Nameplate (on rocker arm cover)
- 2 – Coolant Pump
- 3 – Belt Cover
- 4 – Seawater Pump
- 5 – Coolant Filler Cap
- 6 – Coolant Tank / Heat Exchanger
- 7 – Exhaust Manifold
- 8 – Starter Motor
- 9 – Alternator

Right Side (Viewed from Flywheel) - 4JH4-TE

Figure 5 and Figure 6 illustrate a typical version of a 4JH4-TE engine. Your engine may have different equipment from that illustrated.

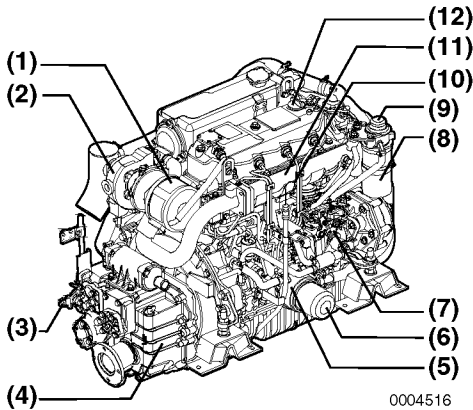

Figure 5

- 1 – Intake Silencer (air cleaner)
- 2 – Turbocharger
- 3 – Shift Lever
- 4 – Marine Gear (KMH4A shown)
- 5 – Engine Oil Cooler
- 6 – Engine Oil Filter
- 7 – Fuel Injection Pump
- 8 – Fuel Filter
- 9 – Fuel Priming Pump
- 10 – Engine Oil Dipstick
- 11 – Intake Manifold
- 12 – Engine Oil Filler Cap

Left Side (Viewed from Flywheel) - 4JH4-TE

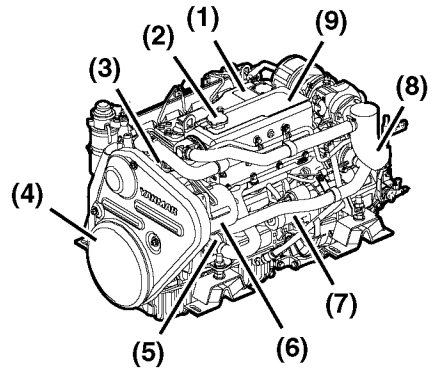

Figure 6

- 1 – Engine Nameplate (on rocker arm cover)
- 2 – Coolant Filler Cap
- 3 – Coolant Pump
- 4 – Belt Cover
- 5 – Seawater Pump
- 6 – Alternator
- 7 – Starter Motor
- 8 – Exhaust / Water Mixing Elbow
- 9 – Coolant Tank / Heat Exchanger

PRODUCT OVERVIEW

Right Side (Viewed from Flywheel) - 4JH4-HTE1 / 4JH4-HTE

Figure 7 and Figure 8 illustrate a typical version of a 4JH4-HTE1, 4JH4-HTE engine. Your engine may have different equipment from that illustrated.

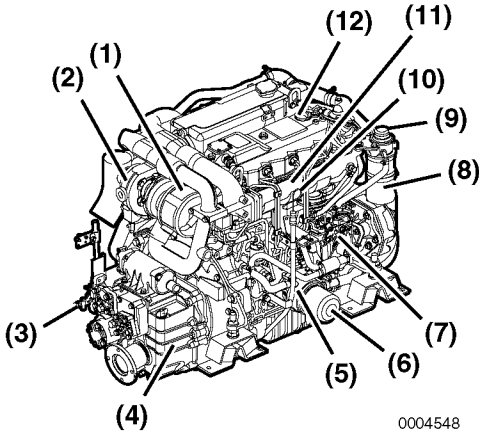

Figure 7

- 1 – Intake Silencer
- 2 – Turbocharger
- 3 – Shift Lever (KMH4A)
- 4 – Marine Gear (KMH4A)
- 5 – Engine Oil Cooler
- 6 – Engine Oil Filter
- 7 – Fuel Injection Pump
- 8 – Fuel Filter
- 9 – Fuel Priming Pump
- 10 – Engine Oil Dipstick
- 11 – Intake Manifold
- 12 – Engine Oil Filler Cap

Left Side (Viewed from Flywheel) - 4JH4-HTE1 / 4JH4-HTE

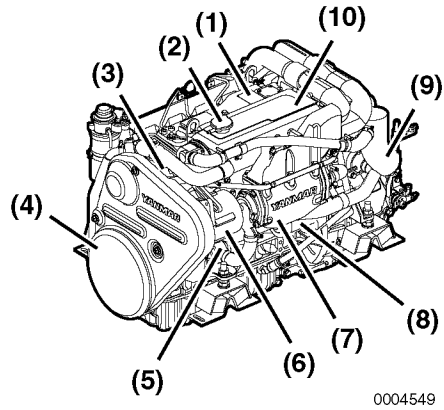

Figure 8

- 1 – Engine Nameplate (on rocker arm cover)
- 2 – Coolant Filler Cap
- 3 – Coolant Pump
- 4 – Belt Cover
- 5 – Seawater Pump
- 6 – Alternator
- 7 – Intercooler
- 8 – Starter Motor
- 9 – Exhaust Mixing Elbow
- 10 – Coolant Tank / Heat Exchanger

NAMEPLATES

The nameplates of Yanmar JH series engines are shown in **Figure 9**. Check the engine's model, output, min^{-1} and serial number on the nameplate. Please replace if damaged or lost.

The engine nameplate is attached to the engine rocker arm cover.

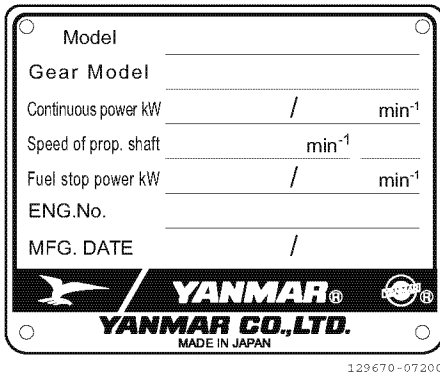

Figure 9

The marine gear nameplate (**Figure 10**) is attached to the marine gear. Check the marine gears model, gear ratio, oil used, oil quantity and serial number.

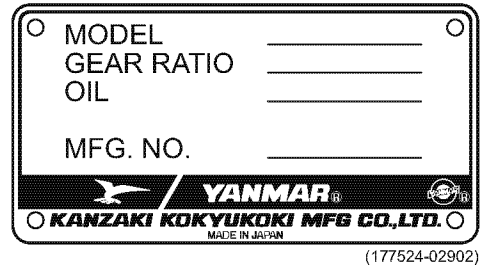

Figure 10

The sail drive nameplate (**Figure 11**) is attached to the sail drive. Check the sail drive model and serial number.

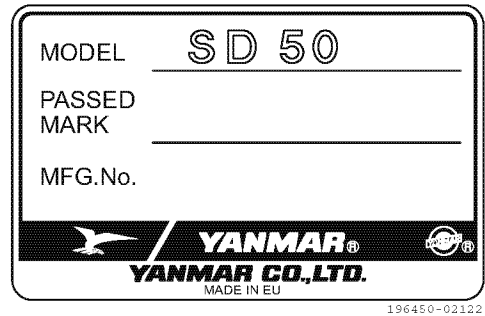

Figure 11

PRODUCT OVERVIEW

FUNCTION OF MAJOR COMPONENTS

Name of Component	Function
Fuel Filter	Removes dirt and water from the fuel. Drain the filter periodically. The filter element should be replaced periodically. The water separator (if equipped) should be drained periodically. See <i>Draining Fuel Filter / Water Separator on page 76.</i>
Fuel Feed Pump	Pumps fuel from the tank to the fuel injection system.
Fuel Priming Pump (if equipped)	This is a manual fuel pump. Pushing the knob on the top of the fuel filter feeds the fuel. The pump is also used to bleed air from the fuel system.
Engine Oil Filler Port	Filler port for engine oil.
Engine Oil Filter	Filters fine metal fragments and carbon from the engine oil. Filtered engine oil is distributed to the engine's moving parts. The filter is a cartridge type and the element should be replaced periodically. See <i>Changing the Engine Oil and Replacing the Engine Oil Filter Element on page 82.</i>
Marine Gear Filler Port	Filler port for marine gear lube oil. Located on top of the marine gear case.
Cooling System	There are two cooling systems: closed cooling with coolant and seawater. The engine is cooled by the closed cooling circuit. The closed circuit is cooled by seawater using a heat exchanger. The seawater also cools the engine / marine gear oil and intake air (depending on model) through the cooler(s) in an open circuit.
Closed Cooling Circulation Pump	The centrifugal water pump circulates coolant inside the engine. The circulating pump is driven by a V-belt.
Seawater Pump	Pumps seawater from outside vessel to the engine. The seawater pump is gear-driven and has a replaceable rubber impeller. Do not operate it without seawater, as this will damage the impeller.
Reservoir	The pressure valve in the filler cap releases vapor and hot water overflow to the reservoir. When the engine stops and the coolant cools, the pressure in reservoir drops. The filler cap vacuum valve then opens to send water back from the reservoir. This minimizes coolant consumption. The closed cooling system coolant level can easily be checked and refilled in this tank.
Oil Cooler - Engine	A heat exchanger that cools high temperature engine oil using coolant.
Oil Cooler - Marine Gear (Optional)	This heat exchanger cools the marine gear (KMH4A) oil using seawater.
Turbocharger (if equipped)	The turbocharger pressurizes the air coming into the engine. It is driven by a turbine that is energized by exhaust gases.
Intercooler (if equipped)	This heat exchanger cools the pressurized charging air from the turbocharger with seawater to increase the charging air quantity.
Intake Silencer (Air Cleaner)	The intake silencer guards against dirt in the air and reduces the noise of air intake.
Nameplates	Nameplates are provided on the engine and the marine gear and have the model, serial number and other data.
Starter	Starter motor for the engine. Powered by the battery.
Alternator	Driven by belt and generates electricity and charges the battery.
Engine Oil Dipstick	Gauge stick for checking the engine oil level.

CONTROL EQUIPMENT

The equipment in the control room makes remote control operation possible. It consists of the instrument panel, which is connected to the engine by a wire harness, and the remote control handle, which is connected by control cables to the engine control lever and marine gear.

Instrument Panel (Optional)

Equipment and Functions

The instrument panel is located in the cockpit. The following instruments enable you to start or stop the engine and to monitor its condition during operation.

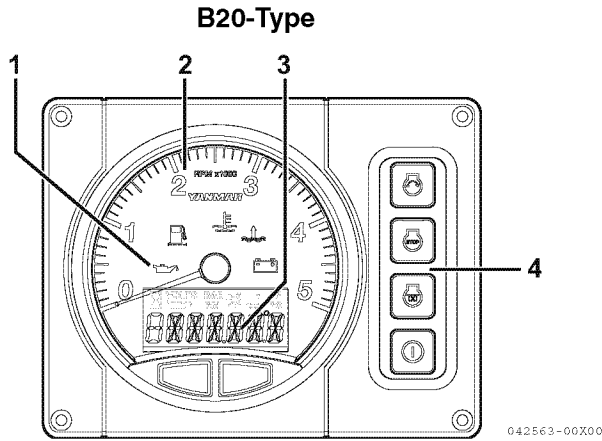

Figure 12

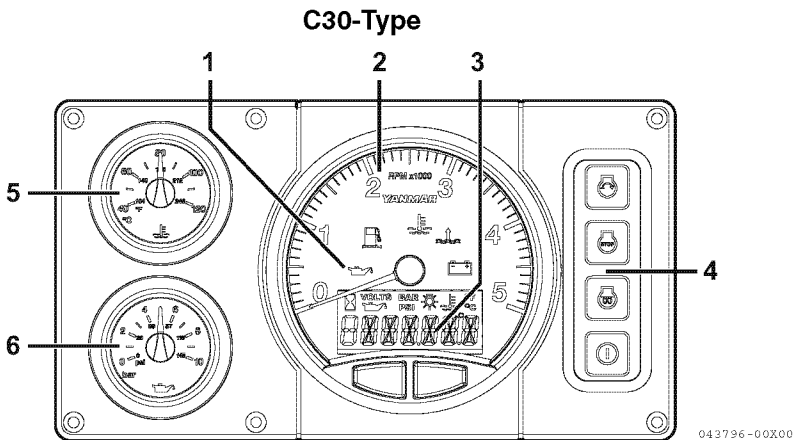

Figure 13

- | | |
|---|---|
| <ul style="list-style-type: none"> 1 – Alarm lamp 2 – Tachometer 3 – LCD | <ul style="list-style-type: none"> 4 – Switches (push-buttons) 5 – Coolant temperature gauge 6 – Engine oil pressure gauge |
|---|---|

PRODUCT OVERVIEW

Meters

Instrument	Function
Tachometer	Shows engine rotation speed.
Hourmeter	Shows number of operating hours. Can be used as a guide for periodic maintenance checks. The hourmeter is located at the bottom of the tachometer.
Coolant Temperature Gauge	Shows the coolant temperature.
Engine Oil Pressure Gauge	Shows the engine oil pressure.
Panel Lights	When the power switch is pushed, the gauges will illuminate for easier viewing.

Note: The LCD on the instrument panel show hourmeter, display brightness and battery voltage.

Coolant temperature and oil pressure display (option)

- B20-Type panels have a digital LCD screen inside the tachometer.
- C30-Type panels have an electric gauge with a needle.

Instrument Panel

The formats for the instrument panel are shown below.

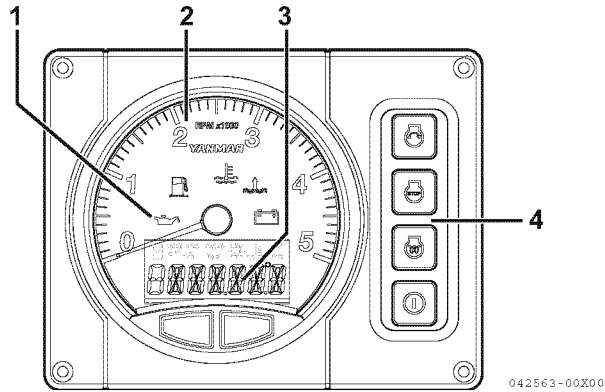

Figure 14

- 1 – Alarm lamp
- 2 – Tachometer

- 3 – LCD
- 4 – Switches (push-buttons)

Control panel switches

All switches are push-buttons.



Start switch

Pushing this switch operates the starter and starts the engine.

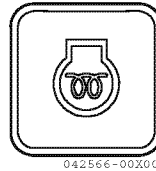

Glow switch

Pushing this switch for the specified time heats the air heater on the air intake manifold. It becomes red-hot, facilitating fuel ignition. This assists starting in cold weather.



Stop switch

Pushing this switch stops the engine.

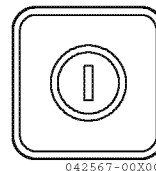

Power switch

Pushing this switch turns on or off the power.

PRODUCT OVERVIEW

Indicators and Alarms (Optional)

When a sensor detects a problem during operation, the indicator on the instrument panel will light and an alarm will sound. Indicators are located on the instrument panel and the alarms are located on the back of the panel. Under normal operating conditions, the indicators are off.



Battery Low Charge Indicator

When the alternator output is too low, the indicator will light. When charging begins, the indicator will turn off.



Coolant High Temperature Indicator and Alarm

When coolant temperature reaches the maximum allowable temperature (95°C [203°F] or higher), the indicator will light and the alarm will sound. Continuing operation at temperatures exceeding the maximum limit will result in damage and seizure. Check the load and troubleshoot the cooling system.



Engine Oil Low Pressure Indicator and Alarm

When the engine oil pressure falls below normal, the oil pressure sensor will send a signal to the indicator, causing it to light and the alarm to sound. Stop operation to avoid damage to the engine. Check the oil level and troubleshoot the lubrication system.



Water in Sail Drive Seal Indicator and Alarm

When water is detected between the seals of the sail drive, the indicator will light and the alarm will sound.



Water in Fuel Filter Indicator and Alarm

- 4JH4-TE, 4JH4-HTE1 and 4JH4-HTE engines only -

When the water level in the fuel filter / water separator becomes too high, the indicator will light and the alarm will sound. Drain the water from the fuel filter / water separator. See *Draining Fuel Filter / Water Separator* on page 76.

LCD control (hourmeter, coolant temperature, display brightness, oil pressure, battery voltage)

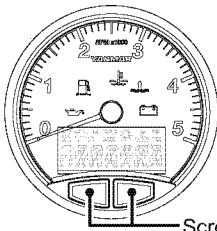

Scroll
Engine hour (>300 min⁻¹)

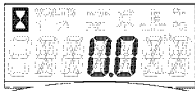

Coolant temperature



Metric



English

Backlighting Brightness

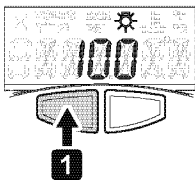

Push and hold
(display will blink when ready)

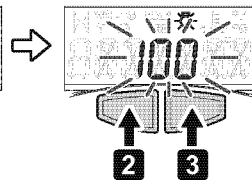

Scroll
100, 80, 60, 40, 20, 0
(value will be set after 3 seconds)

Oil pressure



Metric

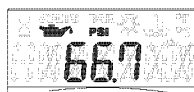

English

Battery voltage



Return to hourmeter

You can switch (scroll) between displays by pressing the buttons on the bottom.

- Switching screens by pressing the right button (Pressing the left button switches the screens in the opposite direction.)

Press the power switch.

- After 4 seconds, the LCD shows the hourmeter.

Pressing the right button on the bottom of the LCD shows the temperature display. Select between Metric units (°C) and Imperial units (°F) at the "System Units screen" on the next page.

Pressing the right button again shows the LCD brightness settings.

To set the brightness of the backlight:

- 1 Press the left button continuously and the digits of the LCD start flashing.
- 2 In this condition, press the right button to decrease the brightness and the left button to increase the brightness. (The brightness changes in 6 steps of 20 %.)
- 3 To set the desired brightness, do not touch the buttons for 3 seconds.

Note: Continuously pressing means holding the button for approx. 2 seconds.

Next, press the right button to show the pressure display.

Select between Metric units (BAR) and Imperial units (PSI) at the "System Units screen" on the next page.

Press again to show the battery voltage.

Pressing the button once more returns the display to the initial hourmeter.

043718-00E00

Setup screen access and control

(Setting the temperature and pressure units and engine speed pulse)

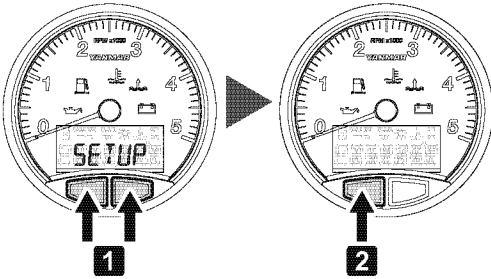

Use the buttons on the bottom of the LCD display to set the instrument panel. Press the left button to switch between displays.

- 1 Press and hold both buttons until "SET UP" appears.
- 2 Press the left button to set the units for the temperature and pressure display.

Setting the temperature and pressure units

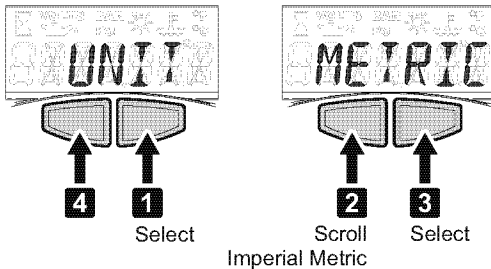

The display says "UNIT".

- 1 Next, press the right button to select Metric units (°C, BAR). The display says "METRIC".
- 2 Press the left button to switch to Imperial units (°F, PSI). The display says "ENGL".
- 3 Press the right button to select and go back to the "UNIT" screen.
- 4 Press the left button and go to the next screen "ENGINE".

Confirm that the display says "ENGINE". Pressing the right button shows the screen for the engine speed pulse setting.

Engine type select

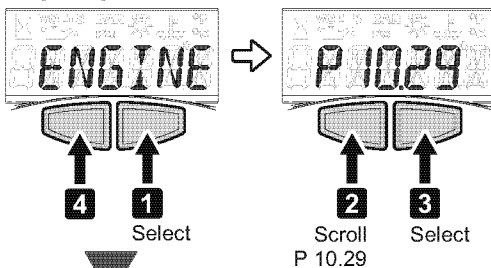

Setting the engine speed pulse value

- 1 Confirm that the display says "ENGINE". Press the right button and "P10.29" appears..

Note: This engine panel is pre-set to a speed pulse of P10.29.

- 2 Confirm that the display says "P10.29". If not, press the left button and change the set value.
- 3 After confirming the above, press the right button to return to the "ENGINE" screen.
- 4 Press the left button again to go from the "ENGINE" screen to the "EXIT" screen.
- 5 After confirming the display, press the right button to re-start the panel and return to the hourmeter display.

Exit setup

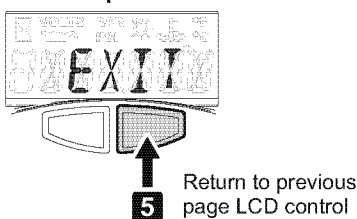

043719-00B00

Alarms

Checking the Warning Devices

Before and after engine start, make sure that the instruments and warning devices operate correctly.

If the engine runs out of coolant or lubricating oil and the instruments and warning devices fail, they can not give you warning to prevent accidents. This can also lead to incorrect operation and cause further malfunctions of the engine.

Before Engine Start

1. Turn on the battery switch.
2. Push the power switch on.
 - All alarm lamps light up for 4 seconds.
 - After 4 seconds, the charge lamp and the lubricating oil pressure alarm lamp light up, and the hourmeter is displayed.
 - The alarm buzzer sounds until the engine starts.

After Engine Start

After engine start, make sure that the warning devices operate correctly and according to “After start” in the below table.

- All alarm lamps turn off. The above check tells you whether the electric circuit for the alarm lamps and alarm buzzer operate correctly. If they do not operate correctly, inspection and repair are required. Consult your dealer or distributor for repairs.

Correct operation of the warning devices				
Instrument panel (power switch)	Power ON			
	Immediately	After 2 seconds	After 4 seconds	
	Before start			After start
Starter switch	OFF			ON
Alarm buzzer	ON			OFF
Charge lamp	ON	ON	ON	OFF
Coolant temperature lamp	ON	ON	OFF	OFF
Engine lubricating oil pressure lamp	ON	ON	ON	OFF
LCD display	Yanmar	Full display	Hourmeter	

NOTICE

When the warning devices are activated and normal operation is impossible, stop the engine and do not use it until the problem has been solved.

Accessory power output

The harness attached to the panel has a terminal where the signal that is synchronized to the panel power supply can be taken off. (**Figure 15**) (Refer to the Wiring Diagrams on page 137.)

The maximum current of this output terminal is 3 A. Do not use a current higher than 3 A. For the content of the output terminal, refer to the Wiring Diagrams on p138.

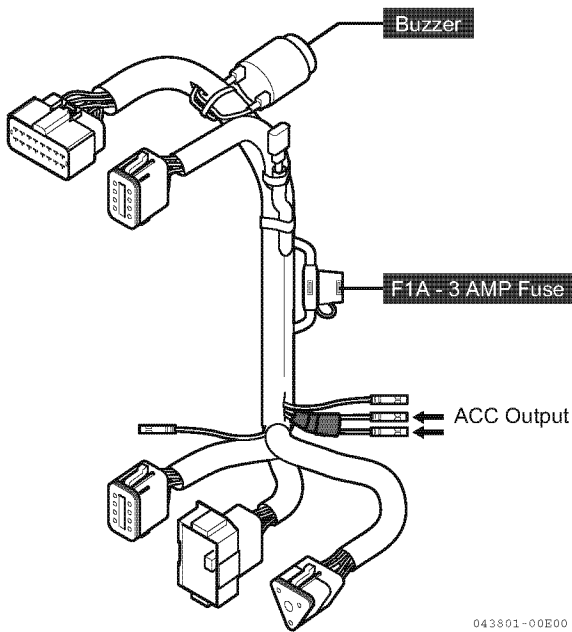
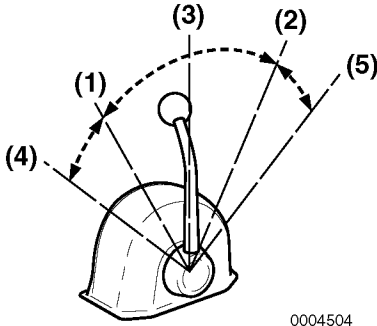

Figure 15

Single-Lever Remote Control Handle



0004504

Figure 16

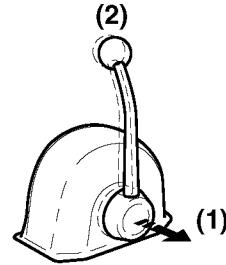

0004511

Figure 17

Note: Direction of travel will vary depending on installation location.

- 1 – Low Speed - FWD or REV**
- 2 – Low Speed - FWD or REV**
- 3 – NEUTRAL - Power to the propeller shaft is cut off and the engine idles**
- 4 – Maximum Engine Speed - FWD or REV**
- 5 – Maximum Engine Speed - FWD or REV**

Note: Yanmar recommends the use of a single-lever type for the remote control system. If only a two-lever type is available in the market, reduce engine speed to 1000 min⁻¹ or less before engaging and disengaging the marine gear clutch.

A single handle-type (**Figure 16**) should be used to operate the marine gear clutch (NEUTRAL, FORWARD and REVERSE) and to control the engine speed.

The handle controls the direction of the boat (ahead or astern) and also acts as an accelerator by increasing engine speed as the lever is pushed further in FORWARD or REVERSE directions.

When the handle is pulled out (**Figure 17, (1)**), the engine speed can be controlled without engaging the clutch. The clutch remains in NEUTRAL, no load position. Turn the knob (**Figure 17, (2)**) counterclockwise to move the handle or clockwise to lock the handle.

This Page Intentionally Left Blank

BEFORE YOU OPERATE

INTRODUCTION

This section of the *Operation Manual* describes the diesel fuel, engine oil and engine coolant specifications and how to replenish them.

SAFETY PRECAUTIONS

Before performing any operations within this section, review the *Safety* section on page 5.

DIESEL FUEL

Diesel Fuel Specifications

WARNING

Fire and Explosion Hazard.
Diesel fuel is flammable and explosive under certain conditions.

Only use diesel fuels recommended by Yanmar for the best engine performance, to prevent engine damage and to comply with EPA warranty requirements. Only use clean diesel fuel.

Diesel fuel should comply with the following specifications. The table lists several worldwide specifications for diesel fuels.

DIESEL FUEL SPECIFICATION	LOCATION
No. 2-D, No. 1-D, ASTM D975	USA
EN590-2009	European Union
ISO 8217 DMX	International
BS 2869-A1 or A2	United Kingdom
JIS K2204 Grade No. 2	Japan

Biodiesel Fuels

Yanmar approves the use of biodiesel fuels that do not exceed a blend of 7% non-mineral oil based fuel with 93% standard diesel fuel. Such biodiesel fuels are known in the marketplace as B7 biodiesel fuels. B7 biodiesel fuel can reduce particulate matter and the emission of “greenhouse” gases compared to standard diesel fuel.

If the B7 biodiesel fuel used does not meet the approved specifications, it will cause abnormal wear of injectors, reduce the life of the engine and it may affect the warranty coverage of your engine.

B7 diesel fuels must meet certain specifications.

The biodiesel fuels must meet the minimum specifications for the country in which they are used:

- In Europe, biodiesel fuels must comply with the European Standard EN590-2009.
- In the United States, biodiesel fuels must comply with the American Standard ASTM D-6751.

Biodiesel should be purchased only from recognized and authorized diesel fuel suppliers.

Precautions and concerns regarding the use of biofuels:

- Biodiesel fuels have a higher content of methyl-esters, which may deteriorate certain metal, rubber and plastic components of the fuel system. The customer and / or boat builder are responsible to verify the usage of biodiesel compatible components on the vessel fuel supply and return systems.
- Free water in biodiesel may result in plugging of fuel filters and increased bacterial growth.
- High viscosity at low temperatures may result in fuel delivery problems, injection pump seizures and poor injection nozzle spray atomization.
- Biodiesel may have adverse effects on some elastomers (seal materials) and may result in fuel leakage and dilution of the engine lubricating oil.

- Even biodiesel fuels that comply with a suitable standard as delivered will require additional care and attention to maintain the quality of the fuel in the equipment or other fuel tanks. It is important to maintain a supply of clean, fresh fuel. Regular flushing of the fuel system, and / or fuel storage containers, may be necessary.
- The use of biodiesel fuels that do not comply with the standards as agreed to by the diesel engine manufacturers and the diesel fuel injection equipment manufacturers, or biodiesel fuels that have degraded as per the precautions and concerns above, may affect the warranty coverage of your engine.

Additional Technical Fuel Requirements

- The fuel cetane number should be 45 or higher.
- The sulfur content must not exceed 0.5% by volume. Less than 0.05% is preferred.
- NEVER mix kerosene, used engine oil or residual fuels with the diesel fuel.
- Water and sediment in the fuel should not exceed 0.05% by volume.
- Keep the fuel tank and fuel-handling equipment clean at all times.
- Ash content not to exceed 0.01% by volume.
- Carbon residue content not to exceed 0.35% by volume. Less than 0.1% is preferred.
- Total aromatics content should not exceed 35% by volume. Less than 30% is preferred.
- PAH (polycyclic aromatic hydrocarbons) content should be below 10% by volume.
- Do not use Biocide.
- Do not use kerosene or residual fuels.

Handling of Diesel Fuel

⚠ WARNING

Fire and Explosion Hazard.
Only fill the fuel tank with diesel fuel. Filling the fuel tank with gasoline may result in a fire and will damage the engine. NEVER refuel with the engine running. Wipe up all spills immediately. Keep sparks, open flames or any other form of ignition (match, cigarette, static electric source) well away when refueling.

Fire and Explosion Hazard.
ALWAYS put the diesel fuel container on the ground when transferring the diesel fuel from the pump to the container. Hold the hose nozzle firmly against the side of the container while filling it. This prevents static electricity buildup which could cause sparks and ignite fuel vapors.

1. Water and dust in the fuel may cause engine failure. When fuel is stored, be sure that the inside of the storage container is clean and dry, and that the fuel is stored away from dirt or rain.

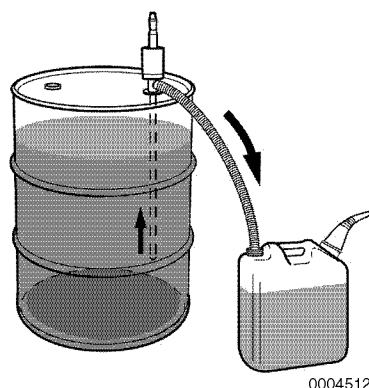

Figure 1

BEFORE YOU OPERATE

2. Keep the fuel container stationary for several hours to allow any dirt or water to settle to the bottom of the container. Use a pump to extract the clear, filtered fuel from the top of the container.

Fuel Tank (Optional)

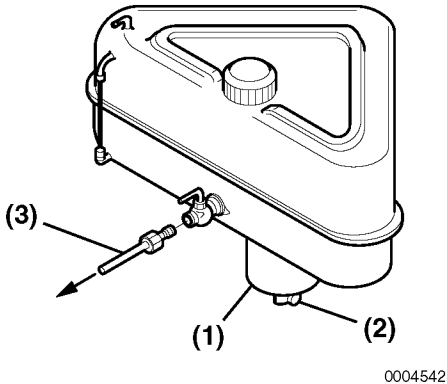

Figure 2

- 1 – Sediment Bowl
- 2 – Drain Cock
- 3 – Fuel Line to Engine

Install a drain cock (**Figure 2, (2)**) at the bottom of the fuel tank to remove water and contaminants from the sediment bowl (**Figure 2, (1)**).

The fuel outlet should be positioned 20 to 30 mm (0.75 to 1.125 in.) above the bottom of the tank so that only clean fuel is distributed to the engine.

Fuel System - 4JH4-TE and 4JH4-HTE1, 4JH4-HTE

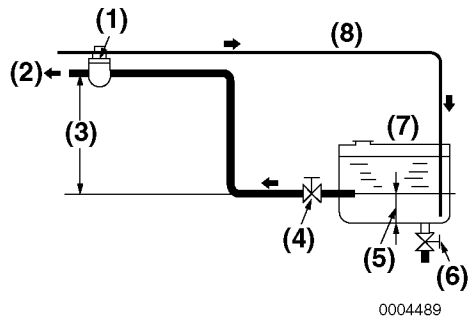

Figure 3

- 1 – Fuel Filter
- 2 – To Fuel Injection Pump
- 3 – Less than 500 mm (20.0 in.)
- 4 – Fuel Cock
- 5 – 20 to 30 mm (0.75 to 1.125 in.)
Approximate
- 6 – Drain Cock
- 7 – Fuel Tank
- 8 – Fuel Return Line

Install the fuel line from the fuel tank to the fuel injection pump as shown in **Figure 3**. The recommended fuel / water separator (optional) is installed at the center section of that line.

Fuel System - 3JH5E and 4JH5E

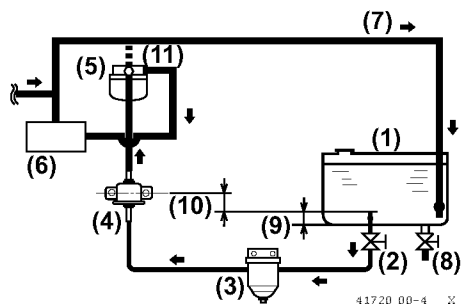

Figure 4

- 1 – Fuel Tank
- 2 – Fuel Cock
- 3 – Water Separator
- 4 – Fuel Feed Pump
- 5 – Fuel Filter
- 6 – Fuel Injection Pump
- 7 – Fuel Return Line
- 8 – Drain Cock
- 9 – 20 to 30 mm (0.75 to 1.25 in.)
Approximate
- 10 – Less than 400 mm (16.38 in.)
- 11 – Orifice for Air Bleeding

Filling the Fuel Tank

Before filling fuel tank for the first time:

⚠ WARNING

Fire and Explosion Hazard.
NEVER refuel with the engine running.

Rinse fuel tank with kerosene or diesel fuel. Dispose of waste properly.

To fill the fuel tank:

⚠ WARNING

Fire and Explosion Hazard.
Operate bilge ventilation (blowers) for a minimum of 5 minutes to purge fumes from engine compartment after refueling. Never operate bilge blower while refueling. Doing so can pump explosive fumes into the engine compartment and result in an explosion.

1. Clean the area around the fuel cap.
2. Remove the fuel cap from the fuel tank.
3. Fill the tank with clean fuel free of oil and dirt.

⚠ WARNING

Fire and Explosion Hazard.
Hold the hose nozzle firmly against the filler port while filling. This prevents static electricity buildup which could cause sparks and ignite fuel vapors.

4. Stop fueling when the gauge shows the fuel tank is full.

⚠ WARNING

Fire and Explosion Hazard.
NEVER overfill the fuel tank.

5. Replace the fuel cap and hand-tighten. Over-tightening the fuel cap will damage it.

BEFORE YOU OPERATE

Bleeding the Fuel System

The fuel system has an automatic air bleeding device that purges air from the fuel system. No manual air bleeding is required for normal operation. Bleeding must be done if any fuel system maintenance has been performed (replacement of fuel filter, etc.) or if the engine does not start after several attempts.

Figure 5 applies to both 4JH5E and 3JH5E.

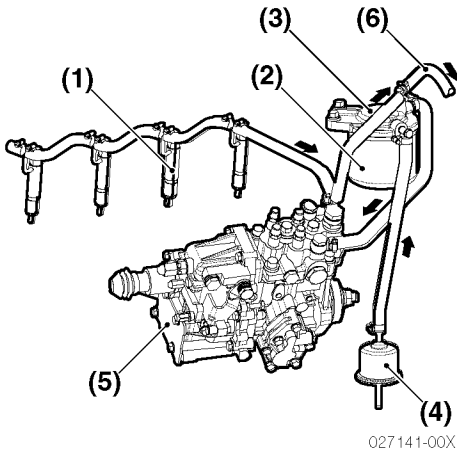

Figure 5

- 1 – Fuel Injector
- 2 – Fuel Filter
- 3 – Header (fuel filter)
- 4 – Electric Fuel Feed Pump
- 5 – Fuel Injection Pump

1. Check the fuel level in the fuel tank. Refill if necessary.
2. Open the fuel cock of the fuel tank.
3. To bleed air from the fuel filter, loosen the hose clamp on the return side fuel hose (**Figure 5, (4)**) at the T-joint. Remove the hose.
4. Push the power switch on to activate the electric fuel feed pump.

5. Continue pumping until a solid stream of fuel with no air bubbles begins to flow from the T-joint. Push the power switch off.
6. Install the return side fuel hose onto the T-joint. Tighten hose clamp.

Bleeding the Fuel System - 4JH4-TE and 4JH4-HTE1, 4JH4-HTE

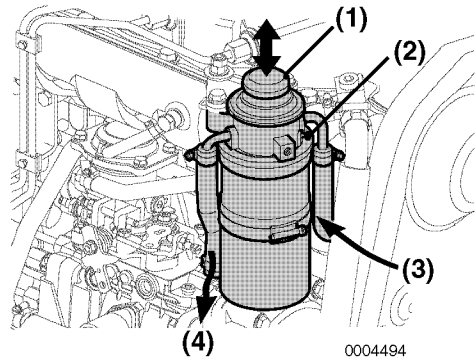

Figure 6

- 1 – Priming Pump
- 2 – Air Bleed Screw
- 3 – From Fuel Tank
- 4 – To Fuel Injection Pump

1. Check the fuel level in the fuel tank. Refill if necessary.
2. Open the fuel cock of the fuel tank.

WARNING

Exposure Hazard.
Always wear safety glasses when bleeding the fuel system.

3. Loosen the air bleed screw (**Figure 6, (2)**) two to three turns.
4. Push up and down on the priming pump (**Figure 6, (1)**) to release air out of the air bleed screw.

5. Continue pumping until a solid stream of fuel with no air bubbles begins to flow.
6. Tighten the air bleed screw.

NOTICE

NEVER use an engine starting aid such as ether. Engine damage will result.

ENGINE OIL

Engine Oil Specifications

Using engine oil that does not meet or exceed the following guidelines or specifications may cause seizure of parts, abnormal wear and shorten engine life.

Service Categories

Use an engine oil that meets or exceeds the following guidelines and classifications:

- *4JH4-TE and 4JH4-HTE1, 4JH4-HTE:*
API Service Categories CD, CF, CF-4 and CI-4.
- *3JH5E and 4JH5E:*
API Service Category CF, CF-4 and CI-4.
- SAE Viscosity:
10W30, 15W40. Engine oil 10W30 and 15W40 can be used throughout the year.

NOTICE

- Be sure the engine oil, engine oil storage containers and engine oil filling equipment are free of sediment or water.
 - Change the engine oil after the first 50 hours of operation and then at every 250 hours thereafter.
 - Select the oil viscosity based on the ambient temperature where the engine is being operated. See the SAE Service Grade Viscosity Chart (**Figure 7**).
 - Yanmar does not recommend the use of engine oil “additives”.
-

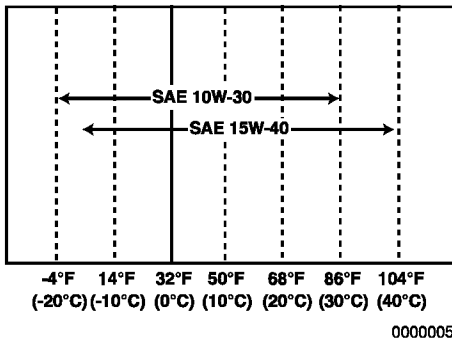

Figure 7

Handling Engine Oil

1. When handling and storing engine oil, be careful not to allow dust and water to contaminate the oil. Clean around the filler port before filling.
2. Do not mix lube oils of different types or brands. Mixing may cause the chemical characteristics of the oil to change and lubricating performance to decrease, reducing the engine's life.
3. Engine oil should be replaced at the specified intervals, regardless if the engine has been operated.

Engine Oil Viscosity

SAE 10W30 or SAE 15W40 are the recommended oil viscosities.

If you operate your equipment at temperatures outside the limits shown, consult your authorized Yanmar dealer or distributor for special lubricants or starting aids.

Checking the Engine Oil

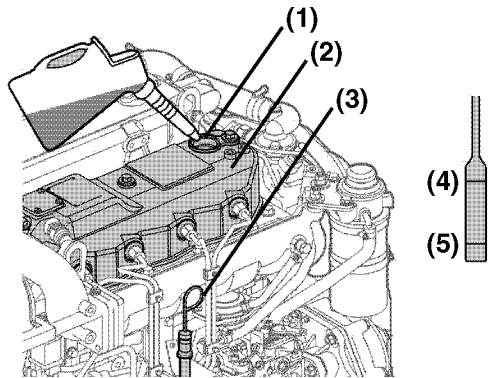

0004490

Figure 8

Note: 4JH4-TE shown. Other models are similar.

1. Make sure the engine is level.
2. Remove dipstick (**Figure 8, (3)**) and wipe with clean cloth.
3. Fully reinsert dipstick.
4. Remove dipstick. The oil level should be between upper (**Figure 8, (4)**) and lower (**Figure 8, (5)**) lines on the dipstick.
5. Add oil if necessary. See *Adding Engine Oil* on page 40.
6. Fully reinsert dipstick.

Adding Engine Oil

1. Remove the yellow oil filler port cap from filler port (**Figure 8, (1)**) and fill with engine oil.

NOTICE

Prevent dirt and debris from contaminating engine oil. Carefully clean the dipstick and the surrounding area before you remove the cap.

2. Fill with oil to the upper limit (Figure 8, (4)) on the dipstick (Figure 8, (3)).

NOTICE

NEVER overfill the engine with engine oil.

3. Insert the dipstick fully to check the level.

NOTICE

ALWAYS keep the oil level between upper and lower lines on the oil cap / dipstick.

4. Hand-tighten the filler port cap securely.

MARINE GEAR OR SAIL DRIVE OIL

Marine Gear Oil Specifications

Use marine gear oil that meets or exceeds the following guidelines and classifications:

KM35P, KM35A, KM35A2, KM4A1, KM4A2, KMH4A:

- API Service Categories CD or higher
- SAE Viscosity #20 or #30

ZF30M, ZF25A:

- ATF (Automatic Transmission Fluid)

Sail Drive Oil Specifications

Refer to the *Operation Manual* of the sail drive for the procedure to fill or replace the sail drive oil.

3JH5E, 4JH5E (SD50):

- Quick Silver[®] 1 High Performance Gear Lube

4JH4-TE (SD50-4T):

- Only use Quick Silver[®] High Performance Gear Lube.

Checking Marine Gear Oil

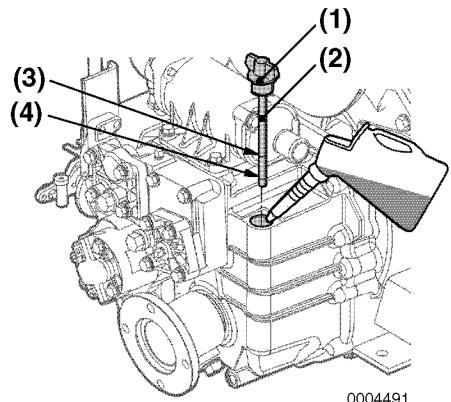

Figure 9

¹Quick Silver is a registered trademark of Brunswick © Corporation.

BEFORE YOU OPERATE

Note: 4JH4-TE with KMH4A marine gear shown.

1. Make sure engine is level.
2. Remove the filler cap (**Figure 9, (1)**) at the top of the housing.
3. Remove dipstick (**Figure 9, (2)**) and wipe with clean cloth.
4. Fully reinsert dipstick.
5. Remove dipstick. The oil level should be between upper (**Figure 9, (3)**) and lower (**Figure 9, (4)**) lines on the dipstick.
6. Fully reinsert dipstick.

Adding Marine Gear Oil

1. Make sure the engine is level.
2. Remove the filler cap (**Figure 9, (1)**) at the top of the housing.
3. Fill with oil to the upper limit on the dipstick (**Figure 9, (3)**). See *Marine Gear Oil Specifications* on page 41.

NOTICE

NEVER overfill the marine gear with oil.

4. Fully reinsert dipstick.
5. Tighten the filler port cap by hand.

Checking and Adding Sail Drive Oil

Refer to the operation manual for SD50-T for the procedure to check and fill the sail drive oil.

ENGINE COOLANT

Engine Coolant Specifications

Note: In the U.S., LLC is required for the warranty to be valid.

- Texaco Long Life Coolant (LLC), both standard and premixed, product code 7997 and 7998
- Havoline Extended Life Antifreeze / Coolant, product code 7994

Following the manufacturer's recommendations, use a proper LLC which will not have any adverse effects on the materials (cast iron, aluminum, copper, etc.) of the engine's cooling system.

ALWAYS use the mixing ratios specified by the antifreeze manufacturer for the temperature range.

Coolant (Closed Cooling System)

NOTICE

ALWAYS add LLC to soft water especially when operating in cold weather. NEVER use hard water. Water should be clean and free from sludge or particles. Without LLC, cooling performance will decrease due to scale and rust in the coolant system. Water alone may freeze and form ice; it expands approximately 9% in volume. Use the proper amount of coolant concentrate for the ambient temperature as specified by the LLC manufacturer. LLC concentration should be a minimum of 30% to a maximum of 60%. Too much LLC will decrease the cooling efficiency. Excessive use of antifreeze also lowers the cooling efficiency of the engine. NEVER mix different types or brands of LLC, as a harmful sludge may form. Mixing different brands of antifreeze may cause chemical reactions, and may make the antifreeze useless or cause engine problems.

Checking and Adding Coolant

3JH5E

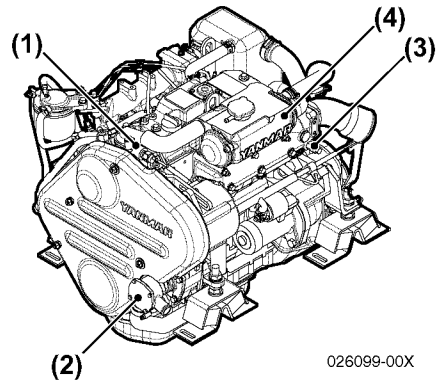
**Figure 10**

- 1 – Coolant Pump
- 2 – Seawater Drain from Seawater Pump Cover
- 3 – Coolant Drain Cock
- 4 – Coolant Tank (heat exchanger)

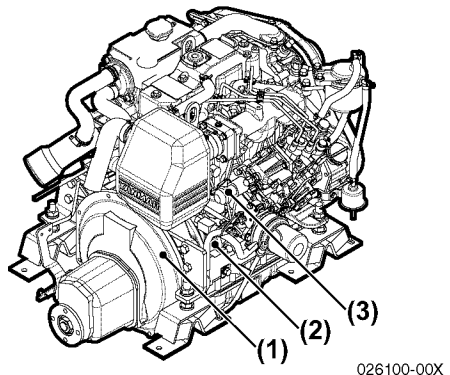
**Figure 11**

- 1 – Flywheel Housing
- 2 – Coolant Drain Cock
- 3 – Stop Solenoid

BEFORE YOU OPERATE

4JH5E

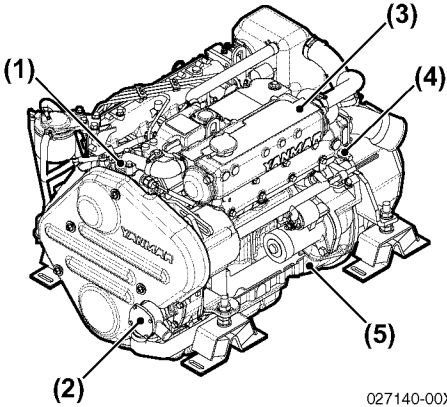

027140-00X

Figure 12

- 1 – Coolant Pump
- 2 – Seawater Drain from Seawater Pump Cover
- 3 – Coolant Tank (heat exchanger)
- 4 – Coolant Drain Cock
- 5 – Flywheel Housing

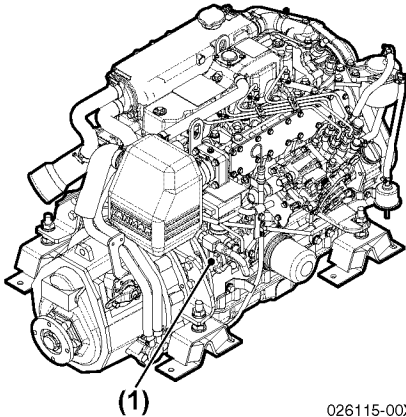

026115-00X

Figure 13

- 1 – Coolant Drain Cock

4JH4-TE

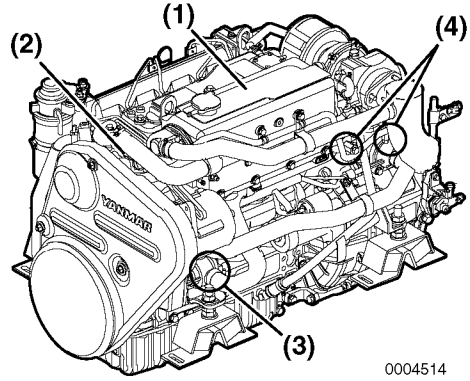

0004514

Figure 14

- 1 – Coolant Tank (heat exchanger)
- 2 – Coolant Pump
- 3 – Seawater Drain from Seawater Pump Cover
- 4 – Coolant Drain Cock (2 used)

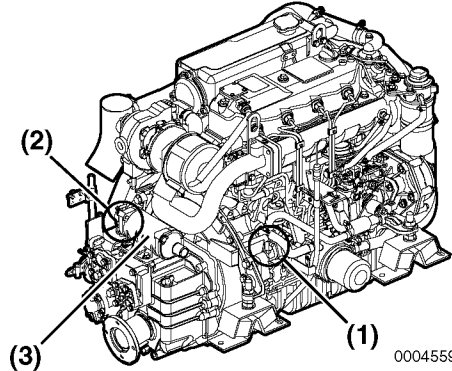

0004559

Figure 15

- 1 – Coolant Drain Cock
- 2 – Seawater Drain Cock
- 3 – Marine Gear Cooler

4JH4-HTE1 / 4JH4-HTE

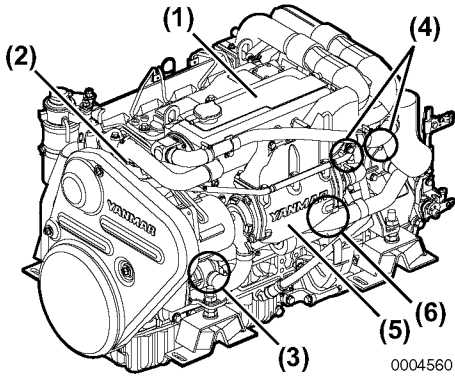

Figure 16

- 1 – Coolant Tank (heat exchanger)
- 2 – Coolant Pump
- 3 – Seawater Drain from Seawater Pump Cover
- 4 – Coolant Drain Cock
- 5 – Intercooler
- 6 – Seawater Drain Cock

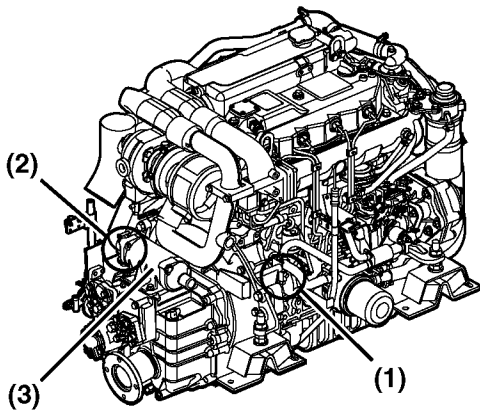

Figure 17

- 1 – Coolant Drain Cock
- 2 – Seawater Drain Cock
- 3 – Marine Gear Cooler

1. Ensure all drain cocks are closed.

Note: The drain cocks are opened before shipping from the factory. Marine gear ZF25A does not have a drain cock on the clutch cooler.

2. Loosen the filler cap of reservoir to relieve the pressure, then remove the filler cap.

⚠ WARNING

Burn Hazard.

NEVER remove the coolant filler cap if the engine is hot. Steam and hot engine coolant will spray out and seriously burn you. Allow the engine to cool down before you attempt to remove the cap.

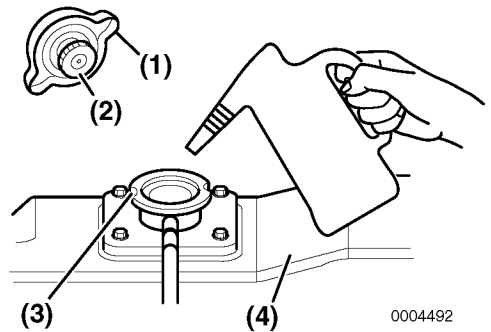

Figure 18

- 1 – Coolant Filler Cap
- 2 – Filler Cap Tabs
- 3 – Filler Port Notches
- 4 – Coolant Tank

3. Pour coolant slowly into reservoir (Figure 18, (4)) to avoid air bubbles. Fill until coolant overflows from the filler port.

BEFORE YOU OPERATE

NOTICE

NEVER pour cold coolant into a hot engine.

- Align filler cap tabs (**Figure 18, (2)**) with filler port notches (**Figure 18, (3)**) and tighten filler cap (**Figure 18, (1)**) firmly.

NOTICE

ALWAYS tighten reservoir cap securely after checking reservoir. Steam can spray out during engine operation if the cap is loose.

Note: The coolant level rises in the reservoir during operation. After stopping the engine, the coolant will cool down and the extra coolant will return to reservoir.

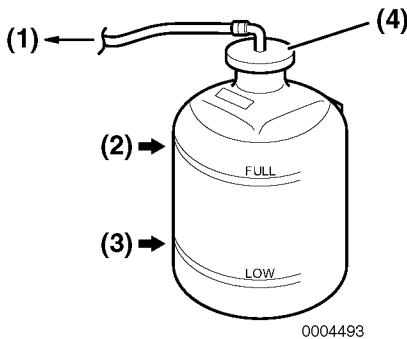

Figure 19

- Check the coolant level in the reservoir. The level should be at the FULL mark (**Figure 19, (2)**). Add coolant if necessary.

NOTICE

NEVER pour cold coolant into a hot engine.

- Remove reservoir cap (**Figure 19, (4)**) to add coolant if necessary. Do not add water.
- Replace filler cap and tighten it firmly. Failure to do so will cause water leakage.

Reservoir Capacity
0.8 L (0.85 qt)

- Check the rubber hose (**Figure 19, (1)**) connecting the reservoir to reservoir / heat exchanger. Replace if damaged.

Note: If the coolant runs low too often or the coolant level in reservoir drops without any change in the level in the reservoir, there may be water or air leaks in the cooling system. See your authorized Yanmar dealer or distributor.

CRANKING THE ENGINE

NOTICE

When the engine has not been used for a long period of time, engine oil will not be distributed to all of the operating parts. Using the engine in this condition will lead to seizure. After a long period of no use, distribute engine oil to each part by cranking. Perform in accordance with the following procedures before beginning operation.

1. Open seacock.
2. Open fuel cock.
3. Put remote control shift lever in NEUTRAL. *See Starting the Engine on page 51.*
4. Turn on the battery switch (if equipped).
5. Crank the engine.
 - 1- Push the power switch on the instrument panel and turn on the power.
 - 2- 3JH5E/4JH5E models:
Operate the starter while pushing in the emergency stop button (**Figure 20, (1)**) on the back of the fuel pump. This stops the fuel supply.

4JH4-TE / 4JH4-HTE1 / 4JH4-HTE models:

Operate the starter while moving and holding (**Figure 21, (1)**) the stop lever (**Figure 21, (2)**) on the governor to stop fuel flow.

When you push the start switch on the instrument panel while the emergency button is pushed in, the starter operates and the engine cranks.

Crank the engine 5 seconds.

3JH5E / 4JH5E models:

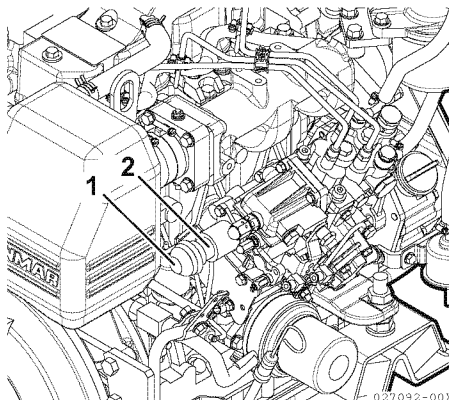

Figure 20

4JH4-TE / 4JH4-HTE1 / 4JH4-HTE models:

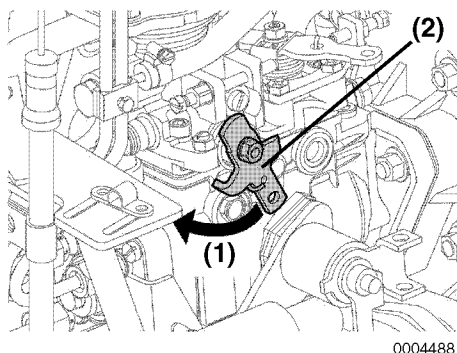
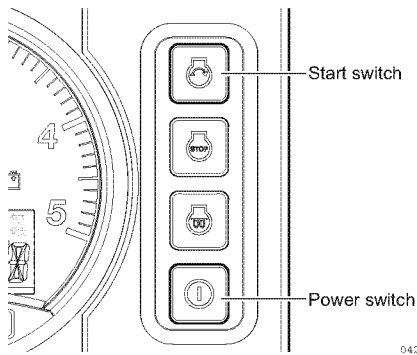

Figure 21

6. Continue cranking the engine for about 5 seconds, checking for abnormal sounds.
If you cannot find any abnormal sounds, push the power switch and turn off the engine.



042590-00E00

Figure 22

⚠ WARNING



Never touch or allow your clothes to touch the moving parts of the engine during operation. If a part of your body or clothing is caught in the front drive shaft, V-belt, propeller shaft, etc. serious injury may result. Check to see that no tools, pieces of cloth, etc. are left on or around the engine.

ENGINE OPERATION

INTRODUCTION

This section of the *Operation Manual* describes the diesel fuel, engine oil and engine coolant specifications and how to replenish them. It also describes the daily engine checkout.

SAFETY PRECAUTIONS

Before performing any operations within this section, review the *Safety* section on page 5.

WARNING

Fire and Explosion Hazard



NEVER jump-start the engine. Sparks caused by shorting the battery to the starter terminals may cause a fire or explosion. **ONLY** use the start switch on the instrument panel to start the engine.

Sudden Movement Hazard

Be sure the boat is in open water away from other boats, docks or other obstructions before increasing engine speed. Avoid unexpected equipment movement. Shift the marine gear into the **NEUTRAL** position any time the engine is at idle.

To prevent accidental equipment movement, **NEVER** start the engine in gear.

Sever Hazard



Keep children and pets away while the engine is operating.

NOTICE

If any indicator illuminates during engine operation, stop the engine immediately. Determine the cause and repair the problem before you continue to operate the engine.

If the alarm indicator with audible alarm fails to display and go out about 3 seconds after the ignition switch is turned on, see your authorized Yanmar Marine dealer or distributor for service before operating the engine

If the vessel is equipped with a water lift (water lock) muffler, excessive cranking could cause seawater to enter the cylinders and damage the engine. If the engine does not start after cranking for 10 seconds, close the thru-hull water intake valve to avoid filling the muffler with water. Crank for 10 seconds at a time until the engine starts. When the engine does start, stop the engine immediately and turn off the switch.

Be sure to re-open the seacock and restart the engine. Operate the engine normally.

Observe the following environmental operating conditions to maintain engine performance and avoid premature engine wear:

- Avoid operating in extremely dusty conditions.
- Avoid operating in the presence of chemical gases or fumes.
- **NEVER** run the engine if the ambient temperature is above +40°C (+104°F) or below -16°C (+5°F).
- If the ambient temperature exceeds +40°C (+104°F), the engine may overheat and cause the engine oil to break down.
- If the ambient temperature is below -16°C (+5°F), rubber components such as gaskets and seals will harden causing premature engine wear and damage.

NOTICE

- Contact your authorized Yanmar Marine engine dealer or distributor if the engine will be operated outside of this standard temperature range.

NEVER engage the starter motor while the engine is running. Damage to the starter motor pinion and / or ring gear will result.

STARTING THE ENGINE

1. Open the seacock (if equipped).
2. Open the fuel tank cock.
3. Put remote control handle in NEUTRAL.

Note: Safety equipment should make it impossible to start the engine in any other position than NEUTRAL.

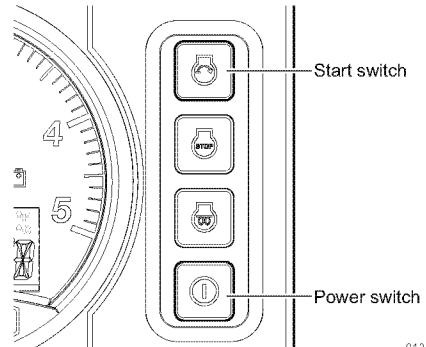

Figure 1

4. Turn on the battery switch (if equipped). Do not turn off the battery switch during engine operation. Also, turn it off when the engine does not operate.
5. If the alarm buzzer and all alarm lamps operate when you turn on the power switch on the instrument panel, the warning devices operate correctly.
6. Pushing the start switch turns on the engine. Release the switch after the engine starts. If the alarm lamps and the alarm buzzer stops operating, the warning devices operate correctly.

If the Engine Fails to Start

Before pushing the start switch again, be sure to confirm that the engine has stopped completely. If an attempt to restart is made while the engine is running, the pinion gear of the starter motor will be damaged.

NOTICE

NEVER hold for longer than 15 seconds or the starter motor will overheat.

NEVER attempt to restart the engine if the engine has not stopped completely. Pinion gear and starter motor damage will occur.

Note: Push and hold the start switch for a maximum of 15 seconds. If the engine does not start the first time, wait for about 15 seconds before trying again.

NOTICE

If the vessel is equipped with a water lift (water lock) muffler, excessive cranking could cause seawater to enter the cylinders and damage the engine. If the engine does not start after cranking for 15 seconds, close the thru-hull water intake valve to avoid filling the muffler with water. Crank for 10 seconds at a time until the engine starts. When the engine does start, stop the engine immediately and turn off the power switch. Be sure to re-open the seacock and restart the engine. Operate the engine normally.

Air Bleeding the Fuel System After Starting Failure

If the engine does not start after several attempts, there may be air in the fuel system. If air is in the fuel system, fuel cannot reach the fuel injection pump. Bleed the air out of the system. See *Bleeding the Fuel System on page 38*.

Starting at Low Temperatures

Comply with local environmental requirements. Use engine heaters to avoid starting problems and white smoke. Do not use starting aids.

NOTICE

NEVER use an engine starting aid such as ether. Engine damage will result.

To limit white smoke, run the engine at low speed and under moderate load until the engine reaches normal operating temperature. A light load on a cold engine provides better combustion and faster engine warm-up than no load.

Avoid running the engine at idling speed any longer than necessary.

Starting with Air Heater (If Equipped)

1. Open the seacock (if equipped).
2. Open the fuel tank cock.
3. Put remote control handle in NEUTRAL.
4. Turn the battery switch on (if equipped).
5. Push the power switch on. Ensure that the instrument panel indicators light and the alarm sounds. This shows that indicators and alarm are working correctly.

Note: The coolant high temperature alarm indicator does not come on during start-up.

6. Push and hold the glow switch for 15 seconds.
7. Push the start switch. Release the start switch when the engine has started. The alarm should stop and the indicators should go out.

NOTICE

NEVER hold the start switch for longer than 15 seconds or the starter motor will overheat.

After the Engine has Started

After the engine has started, check the following items at a low engine speed:

1. Check that the gauges, indicators and alarm are normal.
 - Normal coolant operating temperature is approximately 76° to 90°C (169° to 194°F).
 - Normal oil pressure at 3000 min⁻¹ is 0.28 to 0.54 MPa (41 to 78 psi).
2. Check for water, fuel or oil leakage from the engine.
3. Check that the smoke color, engine vibration and sound are normal.
4. When there are no problems, keep the engine at low speed with the boat still stopped to distribute engine oil to all parts of the engine.
5. Check that sufficient cooling water is discharged from the seawater outlet. Operation with inadequate seawater discharge will damage the impeller of the seawater pump. If seawater discharge is too low, stop the engine immediately. Identify the cause and repair.

NOTICE

The engine will seize if it is operated when seawater discharge is too small or if load is applied without any warming up operation.

For troubleshooting assistance, see *Troubleshooting After Starting on page 89* or *Troubleshooting Chart on page 91*. If necessary, see your authorized Yanmar dealer or distributor.

REMOTE CONTROL HANDLE OPERATION

Acceleration and Deceleration

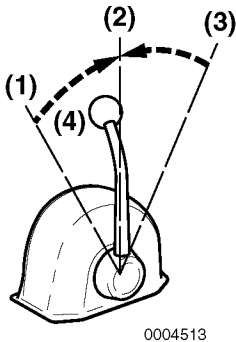

Figure 2

- 1 – FORWARD or REVERSE
- 2 – NEUTRAL
- 3 – REVERSE or FORWARD
- 4 – Throttle Handle / Shifting Handle

Note: Direction of travel will vary depending on installation location.

Use the throttle handle (Figure 2, (4)) to control acceleration and deceleration. Move the handle slowly.

Shifting the Engine

⚠ WARNING

Sudden Movement Hazard.
The boat will start to move when the marine gear is engaged:

- Ensure the boat is clear of all obstacles forward and aft.
- Quickly shift to the FORWARD position then back to the NEUTRAL position.
- Observe whether the boat moves in the direction you expect.

NOTICE

Shifting the marine gear while operating at high speed or not pushing the handle fully into position (partial engagement) will result in damage to marine gear parts and abnormal wear.

1. Before using the marine gear, be sure to move the throttle handle to a low idle position (less than 1000 min⁻¹). Move the throttle handle slowly to a higher speed position after completing marine gear engagement.
2. When moving the handle between FORWARD (Figure 2, (1 or 3)) and REVERSE (Figure 2, (3 or 1)), bring the handle to NEUTRAL (Figure 2, (2)) and pause before slowly shifting to the desired position. NEVER shift abruptly from FORWARD to REVERSE or vice versa.

NOTICE

- NEVER shift the marine gear at high engine speed. During normal operation, the marine gear should only be shifted with the engine at idle.
- When sailing, set the remote control handle in NEUTRAL. Not doing so WILL introduce slippage or any damage and void your warranty.

Switching to Trolling (KMH4A Only)

Use the trolling handle to begin trolling. When changing from FORWARD or REVERSE to trolling, the speed of the propeller revolution will be reduced to a minimum.

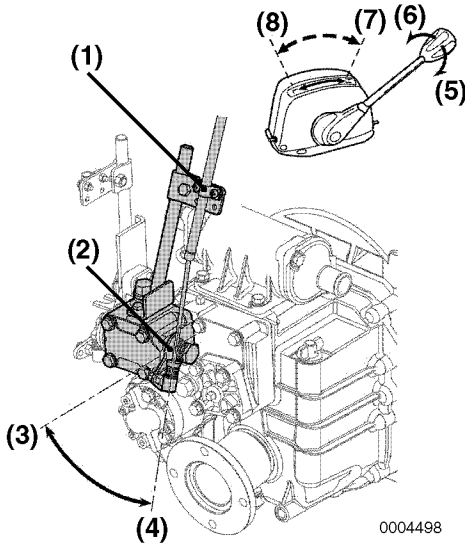

Figure 3

- 1 – Cable Fitting**
- 2 – Trolling Lever**
- 3 – Low Speed (trolling)**
- 4 – High Speed**
- 5 – Loosen**
- 6 – Tighten**
- 7 – Normal Operation (high speed)**
- 8 – Trolling (low speed)**

1. Operation continues at low engine speed of 1000 min^{-1} or less.
2. Reduce the speed by moving the trolling handle from high speed (H) (**Figure 3, (4)**) to low speed (L) (**Figure 3, (3)**). Adjust the speed to the desired rate and secure the trolling handle in place.
3. Before returning to normal operation, be sure to put the trolling handle in high-speed (H) position.
4. Increase engine speed and continue normal operation.

CAUTIONS DURING OPERATION

NOTICE

Engine trouble can arise if the engine is operated for a long time under overloaded conditions with the control handle in the full throttle position (maximum engine speed position), exceeding the continuous rated output engine speed. Operate the engine at about 100 min^{-1} lower than the full throttle engine speed.

Note: If the engine is in the first 50 hours of operation, see *New Engine Break-In* on page 16.

Always be on the lookout for problems during engine operation.

Pay particular attention to the following:

- Is sufficient seawater being discharged from the exhaust and seawater outlet pipe?

If the discharge is small, stop the engine immediately; identify the cause and repair.

- Is the smoke color normal?

The continuous emission of black exhaust smoke indicates engine overloading. This shortens the engines life and should be avoided.

ENGINE OPERATION

- Are there abnormal vibrations or noise?

NOTICE

Excessive vibration may cause damage to the engine, marine gear, hull and onboard equipment. In addition, it causes able passenger and crew discomfort.

Depending on the hull structure, engine and hull resonance may suddenly become great at a certain engine speed range, causing heavy vibrations. Avoid operation in this speed range. If you hear any abnormal sounds, stop the engine and inspect.

- Alarm buzzer sounds during operation.

NOTICE

If any alarm indicator with audible alarm sound appears on the display during engine operation, stop the engine immediately. Determine the cause and repair the problem before you continue to operate the engine.

- Is there water, oil or fuel leakage, or are there any loose bolts?

Check the engine room periodically for any problems.

- Is there sufficient diesel fuel in the diesel fuel tank?

Replenish diesel fuel before leaving the dock to avoid running out of fuel during operation.

- When operating the engine at low speed for long periods of time, race the engine once every 2 hours.

NOTICE

Racing the engine: With the gear in NEUTRAL, accelerate from the low-speed position to the high-speed position and repeat this process about five times. This is done to clean out carbon from the cylinders and the fuel injection valve. Neglecting to race the engine will result in poor smoke color and reduce engine performance.

- If possible, periodically operate the engine at near maximum engine speed while underway. This will generate higher exhaust temperatures, which will help clean out hard carbon deposits, maintaining engine performance and prolonging the life of the engine.

NOTICE

NEVER turn off the battery switch (if equipped) or short the battery cables during operation. Damage to the electric system will result.

SHUTTING DOWN THE ENGINE

Normal Shutdown

1. Reduce engine speed to low idle and put remote control handle in NEUTRAL.
2. Accelerate from low speed to high speed and repeat five times. This will clean out the carbon from the cylinders and the fuel injection nozzles.
3. Allow engine to run at low speed (approximately 1000 min⁻¹) without load for 5 minutes.

NOTICE

For maximum engine life, Yanmar recommends that when shutting the engine down, you allow the engine to idle, without load, for 5 minutes. This will allow the engine components that operate at high temperatures, such as the turbocharger (if equipped) and exhaust system, to cool slightly before the engine itself is shut down.

NOTICE

Continue to hold the stop switch in until the engine is completely stopped. If the switch is released before the engine has completely stopped, it may restart. If the engine does not shut down, see *Emergency Shutdown on page 58*.

5. Turn off the battery switch (if equipped).
6. Close the fuel cock.
7. Close the seacock (if equipped).

NOTICE

- Be sure to close the seacock. Neglecting to close the seacock could allow water to leak into the boat and may cause it to sink.
- If seawater is left inside the engine, it may freeze and damage parts of the cooling system when the ambient temperature is below 0°C (32°F).

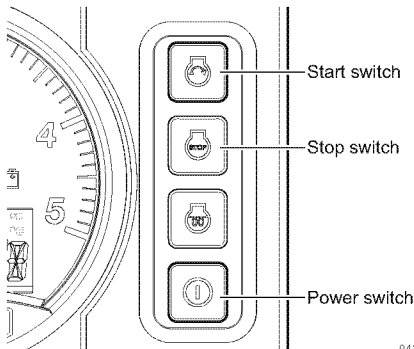

Figure 4

4. Push and hold the stop switch. After the engine has stopped, push the power switch off.

Emergency Shutdown

NOTICE

NEVER use the emergency stop switch for a normal engine shutdown. Use this switch only when stopping the engine suddenly in an emergency.

3JH5E / 4JH5E

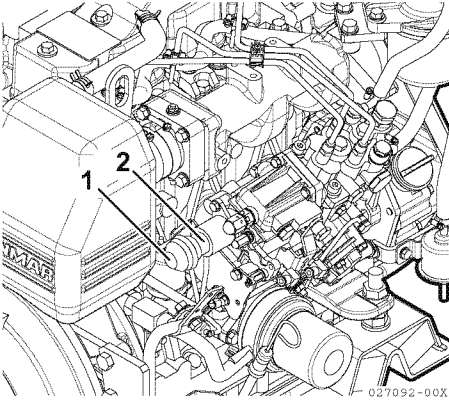

Figure 5

If the engine cannot be shut down by the stop switch on the panel, stop the engine by pushing the button (Figure 5, (1)) at the back of the stop solenoid (Figure 5, (2)).

4JH4-TE / 4JH4-HTE1 / 4JH4-HTE

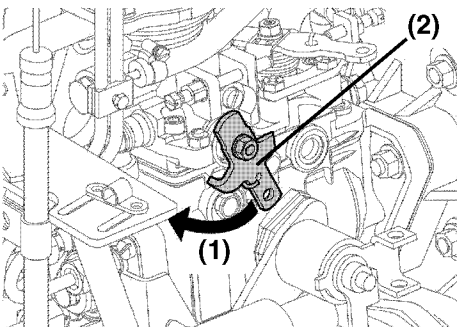

Figure 6

If the engine cannot be shut down by the stop switch on the panel, stop the engine by moving the stop lever (Figure 6, (2)) by hand to the left (Figure 6, (1)). The lever is attached to the fuel injection pump.

WARNING

Sever Hazard.

ALWAYS keep hands, body parts and loose-fitting clothes away from moving / rotating parts such as the flywheel or PTO shaft.

CHECKING THE ENGINE AFTER OPERATION

- Check that the power switch is off and that the battery switch (if equipped) is turned to off.
- Fill the fuel tank. *See Filling the Fuel Tank on page 37.*
- Close seawater cock(s).
- If there is a risk of freezing, check that the cooling system contains enough coolant. **See Engine Coolant Specifications on page 42.**
- If there is a risk of freezing, drain the seawater system. *See Drain Seawater Cooling System on page 94.*
- At temperatures below 0°C (32°F), drain seawater system and connect the engine heater (if equipped).

PERIODIC MAINTENANCE

INTRODUCTION

This section of the *Operation Manual* describes the procedures for proper care and maintenance of the engine.

SAFETY PRECAUTIONS

Before performing any maintenance procedures within this section, read the following safety information and review the *Safety* section on page 5.

WARNING

Crush Hazard



If the engine needs to be transported for repair, have a helper assist you attach it to a hoist and load it on a truck.

The engine lifting eyes are engineered to lift the weight of the marine engine only. **ALWAYS** use the engine lifting eyes when lifting the engine.

Additional equipment is necessary to lift the marine engine and marine gear together. **ALWAYS** use lifting equipment with sufficient capacity to lift the marine engine.

WARNING

Welding Hazard

- **ALWAYS** turn off the battery switch (if equipped) or disconnect the negative battery cable and the leads to the alternator when welding on the equipment.
- Remove the engine control unit multi-pin connector. Connect the weld clamp to the component to be welded and as close as possible to the welding point.
- **NEVER** connect the weld clamp to the engine or in a manner which would allow current to pass through a mounting bracket.
- When welding is completed, reconnect the alternator and engine control unit prior to reconnecting the batteries.

Entanglement Hazard



NEVER leave the power switch on when you are servicing the engine. Someone may accidentally start the engine and not realize you are servicing it.

Shock Hazard



ALWAYS turn off the battery switch (if equipped) or disconnect the negative battery cable before servicing the equipment.

ALWAYS keep the electrical connectors and terminals clean. Check the electrical harnesses for cracks, abrasions, and damaged or corroded connectors.

NEVER use undersized wiring for the electrical system.

Tool Hazard

ALWAYS remove any tools or shop rags used during maintenance from the area before operation.

NOTICE

Any part which is found defective as a result of inspection, or any part whose measured value does not satisfy the standard or limit, must be replaced.

Modifications may impair the engine's safety and performance characteristics and shorten the engine's life. Any alterations to this engine may void its warranty. Be sure to use Yanmar genuine replacement parts.

PRECAUTIONS

The Importance of Periodic Maintenance

Engine deterioration and wear occur in proportion to the length of time the engine has been in service and the conditions the engine is subjected to during operation. Periodic maintenance prevents unexpected downtime, reduces the number of accidents due to poor machine performance and helps extend the life of the engine.

Performing Periodic Maintenance

WARNING

Exhaust Hazard.

NEVER block windows, vents, or other means of ventilation if the engine is operating in an enclosed area. All internal combustion engines create carbon monoxide gas during operation. Accumulation of this gas within an enclosure could cause illness or even death. Make sure that all connections are tightened to specifications after repair is made to the exhaust system. Failure to comply could result in death or serious injury.

The Importance of Daily Checks

The Periodic Maintenance Schedule assumes that the daily checks are performed on a regular basis. Make it a habit to perform daily checks before the start of each operating day. *See Daily Checks on page 70.*

Keep a Log of Engine Hours and Daily Checks

Keep a log of the number of hours the engine is run each day and a log of the daily checks performed. Also note the date, type of repair (e.g., replaced alternator) and parts used for any service needed between the periodic maintenance intervals. Periodic maintenance intervals are every 50, 250, 500 and 1000 engine hours. Failure to perform periodic maintenance will shorten the life of the engine.

NOTICE

Failure to perform periodic maintenance will shorten the life of the engine and may void the warranty.

Yanmar Replacement Parts

Yanmar recommends that you use genuine Yanmar parts when replacement parts are needed. Genuine replacement parts help ensure long engine life.

Tools Required

Before you start any periodic maintenance procedure, make sure you have the tools you need to perform all of the required tasks.

Ask Your Authorized Yanmar Marine Dealer or Distributor for Help

Our professional service technicians have the expertise and skills to help you with any maintenance or service related procedures you need help with.

PERIODIC MAINTENANCE

Tightening Fasteners

Use the correct amount of torque when you tighten fasteners on the engine. Applying excessive torque may damage the fastener or component and not enough torque may cause a leak or component failure.

NOTICE



The tightening torque in the Standard Torque Chart should be applied only to the bolts with a “7” head (JIS strength classification: 7T). Apply 60% torque to bolts that are not listed. Apply 80% torque when tightened to aluminum alloy.

Bolt Diameter x Pitch (mm)		M6x1.0	M8x1.25	M10x1.5	M12x1.75	M14x1.5	M16x1.5
Tightening Torque	N·m	10.8 ± 1.0	25.5 ± 3.0	49 ± 5.0	88.2 ± 10.0	140.0 ± 10.0	230.0 ± 10.0
	ft·lb	8.0 ± 0.7	18.8 ± 2.2	36.2 ± 3.7	65.1 ± 7.4	103 ± 7.2	170 ± 7.2

Taper Plugs		1/8	1/4	3/8	1/2
Tightening Torque	N·m	9.8	19.6	29.4	58.8
	ft·lb	7.4	14.5	21.7	43.2

When lock adhesive is applied, decide separately.

Pipe Joint Bolts		M8	M10	M12	M14	M16
Tightening Torque	N·m	14.7 ± 2	22.5 ± 3	29.4 ± 5	14.1 ± 5	53.9 ± 5
	ft·lb	10.9 ± 1.5	16.6 ± 2.2	21.7 ± 3.7	32.6 ± 3.7	69.8 ± 3.7

When seal washer applied, torque is 34 ± 5 N·m (25.1 ± 3.7 ft·lb).

Main Bolt and Nuts

Name		Thread Diameter x Pitch	Lubricating Oil Application (thread portion and seat surface)	Torque N·m (ft·lb)
Head bolt		M10x1.25	Yes	88.2 ± 3 (65.1 ± 2.2)
Con-rod bolt		M9x1.0	Yes	44.1 to 49.1 (32.6 to 36.3)
Flywheel bolt		M10x1.25	Yes	83.3 to 88.3 (61.5 to 65.2)
Metal cap bolt		M12x1.5	Yes	98 ± 2 (72.3 ± 1.5)
Crank pulley bolt (Material of pulley: FC300)		M14x1.5	Yes	88.2 ± 5 (65.1 ± 3.7)
Nozzle fastening bolt		M8x1.25	—	26.4 ± 2 (19.5 ± 1.5)
FIP gear fastening bolt	3JH5E, 4JH5E	M8x1.0	—	34.3 ± 2 (25.3 ± 1.5)
	4JH4-TE 4JH4-HTE1 4JH4-HTE	M14x1.5	Yes	64 ± 5 (41.6 ± 3.7)
High pressure pipe nut		M12x1.5	—	29.4 to 34.4 (21.7 to 25.4)
Starter relay nut		M6x1	—	3.6 ± 0.6 (2.7 ± 0.4)

EPA MAINTENANCE REQUIREMENTS

To maintain optimum engine performance and compliance with the Environmental Protection Agency (EPA) Regulations for Engines, it is essential that you follow the *Periodic Maintenance Schedule on page 66* and the *Periodic Maintenance Procedures on page 70*.

EPA Requirements for USA and Other Applicable Countries

The following are the requirements for the EPA. Unless these requirements are met, the exhaust gas emissions will not be within the limits specified by the EPA.

See Conditions to Ensure Compliance with EPA Emission Standards on page 64. Clean or replace the air cleaner element if the air intake restriction exceeds the referenced specifications.

EPA Requirements

The EPA emission regulation is applicable only in the USA and other countries that have adopted the EPA requirements in part or in whole. Determine and follow the emission regulations in the country where your engine will be operating to assist you in specified compliance.

PERIODIC MAINTENANCE

Conditions to Ensure Compliance with EPA Emission Standards

The 3JH5E, 4JH5E, 4JH-TE and 4JH4-HTE1 are EPA-certified engines.

The following are the conditions that must be met in order to ensure that the emissions during operation meet the EPA standards.

The operating conditions should be as follows:

- Ambient temperature: -20° to +40°C (-4°F to +104°F)
- Relative humidity: 80% or lower

The diesel fuel should be:

- ASTM D975 No. 1-D or No. 2-D, or equivalent (minimum of cetane No. 45)

The lubricating oil should be:

- **4JH4-TE and 4JH4-HTE1:** Type API, Class CD, CF, CF-4 and CI-4
- **3JH5E and 4JH5E:** Type API, Class CF, CF-4 and CI-4

Be sure to perform inspections as outlined in *Periodic Maintenance Procedures on page 70* and keep a record of the results.

Pay particular attention to these important points:

- Replacing the engine oil
- Replacing the engine oil filter
- Replacing the fuel filter
- Cleaning the intake silencer (air cleaner)

Note: Inspections are divided into two sections in accordance with who is responsible for performing the inspection: the user or the maker.

Emission Control Certification			
Model Year	2011	2012	2013
3JH5E	EPA marine CI Tier 3 (Non-road Tier 2)		
4JH5E / 4JH4-TE	EPA marine CI Tier 3 intermediate		
4JH4-HTE1	-	EPA marine CI Tier 3 intermediate	

Note: Since 2012, the 4JH4-HTE does not comply with the EPA regulation.

Inspection and Maintenance

See *Inspection and Maintenance of EPA Emission-Related Parts on page 69* for the EPA emission-related parts. Inspection and maintenance procedures not shown in *Inspection and Maintenance of EPA Emission-Related Parts on page 69* are covered in *Periodic Maintenance Schedule on page 66*.

This maintenance must be performed to keep the emission values of your engine in the standard values during the warranty period. The warranty period is determined by the age of the engine or the number of hours of operation.

Installation of Exhaust Sampling Port

All engines subject to emission standards shall be equipped with a connection in the engine exhaust system that is located downstream of the engine, and before any point at which the exhaust contacts water (or any other cooling / scrubbing medium), for the temporary attachment of gaseous and / or particulate emissions sampling equipment. This connection shall be internally threaded with standard pipe threads of a size not larger than 12.7 mm (0.5 in.), and shall be closed by a pipe plug when not in use. Equivalent connections are allowed.

The instructions for the proper installation and location of the required sample port, in addition to those specified above in the quoted federal regulation, are as follows:

1. The connection should be located as far downstream as reasonably practicable from any sharp bend (of 30 degrees or more) in the exhaust pipe to help ensure that a well-mixed exhaust flow sample may be taken;
2. The requirement that the connection be located before any point at which the exhaust contacts water (or any other cooling / scrubbing medium) does not include contact with water used to cool exhaust manifolds, unless the water is allowed to come into direct contact with the exhaust gases;
3. To allow ready access to the sample port, the connection should be located, if possible given the constraints of vessel design, approximately 0.6 to 1.8 m (2 to 6 ft) above a deck or walkway;
4. To facilitate insertion and withdrawal of an exhaust sample probe, there should be no obstructions for at least one and one-half exhaust pipe / stack diameters perpendicular, i.e., 90 degrees, from the sample port; and
5. If a threaded connection is used, both the internal and external threads should be coated with a high-temperature, anti-seize compound before the initial installation and at every subsequent re-installation to facilitate removal of the connection for testing.

PERIODIC MAINTENANCE SCHEDULE

Daily and periodic maintenance is important to keep the engine in good operating condition. The following is a summary of maintenance items by periodic maintenance intervals. Periodic maintenance intervals vary depending on engine application, loads, diesel fuel and engine oil used and are hard to establish definitively. The following should be treated only as a general guideline.

NOTICE

Establish a periodic maintenance plan according to the engine application and make sure to perform the required periodic maintenance at the intervals indicated. Failure to follow these guidelines will impair the engine's safety and performance characteristics, shorten the engine's life and may affect the warranty coverage on your engine.

See your authorized Yanmar Marine dealer or distributor for assistance when checking items marked with a ●.

PERIODIC MAINTENANCE

○: Check or Clean ◇: Replace ●: Contact your authorized Yanmar Marine dealer or distributor

System	Item		Periodic Maintenance Interval				
			Daily <i>See Daily Checks on page 70.</i>	Every 50 hours or monthly which-ever comes first	Every 250 hours or 1 year which-ever comes first	Every 500 hours or 2 years which-ever comes first	Every 1000 hours or 4 years which-ever comes first
Whole	Visual inspection of engine exterior		○				
Fuel System	Check the fuel level and refill if necessary		○				
	Drain water and sediment from fuel tank			○ Initial 50	○		
	Drain the fuel / water separator			○			
	Replace the fuel filter element				◇		
	Check the fuel injection timing						●
	Check the fuel injector spray pattern For EPA requirements, see <i>Inspection and Maintenance of EPA Emission-Related Parts on page 69</i> .						●*
Lubricating System	Check the lube oil level	Engine	○				
		Marine Gear	○				
	Replace the lube oil	Engine		◇ Initial 50	◇		
		Marine Gear		◇ Initial 50	◇		
	Replace the oil filter element	Engine		◇ Initial 50	◇		
		Marine Gear (if equipped)		◇ Initial 50	◇		
Cooling System	Seawater outlet		○ During Operation				
	Check coolant level		○				
	Check or replace the seawater pump impeller				○		◇
	Replace coolant		Every year. When Long Life Coolant is used, replace every 2 years. See <i>Engine Coolant Specifications on page 42</i> .				
	Clean and check the seawater passages						●

PERIODIC MAINTENANCE

○: Check or Clean ◇: Replace ●: Contact your authorized Yanmar Marine dealer or distributor

System	Item	Periodic Maintenance Interval				
		Daily See Daily Checks on page 70.	Every 50 hours or monthly which- ever comes first	Every 250 hours or 1 year which- ever comes first	Every 500 hours or 2 years which- ever comes first	Every 1000 hours or 4 years which- ever comes first
Air Intake and Exhaust System	Clean intake silencer (air cleaner) element			○		
	Clean or replace the exhaust / water mixing elbow			○	◇	
	Clean the turbocharger* - 4JH4-TE, 4JH4-HTE1 or 4JH4-HTE only			●		
	Check diaphragm assembly 3JH5E / 4JH5E only					●
Electrical System	Check the alarm and indicators	○				
	Check the electrolyte level in the battery		○			
	Adjust the tension of the alternator V-belt or replace V-belt		○ Initial 50	○		◇
	Check the wiring connectors			○		
Engine Cylinder Head and Block	Check for leakage of fuel, engine oil and engine coolant	○ After starting				
	Tighten all major nuts and bolts			●		
	Adjust intake / exhaust valve clearance		● Initial 50			●
Miscellaneous Items	Check the remote control cable operation		○ Initial 50			●
	Adjust the propeller shaft alignment		● Initial 50			●
	Replace rubberized hoses (fuel and water)	Replace every 2 years.				

* For EPA requirements, see *Inspection and Maintenance of EPA Emission-Related Parts on page 69*.

Note: These procedures are considered normal maintenance and are performed at the owner's expense.

Inspection and Maintenance of EPA Emission-Related Parts

- Marine diesel engines less than 37 kW: 3JH5E is certified as EPA CI marine engine and CARB non-road engine
- Marine diesel engines greater than 37 kW: 4JH5E, 4JH4-TE and 4JH4-HTE1 are certified as EPA CI marine engines

Inspection and Maintenance of EPA Emission-Related Parts for Non-Road and CI Marine Engines

Parts	Interval
Clean fuel injection nozzle	1500 hours
Check fuel injection nozzle pressure and spray pattern	3000 hours
Check fuel injection pump adjustment	
Check turbocharger adjustment (if equipped)	
Check electronic engine control unit and its associated sensors and actuators (if equipped)	

Note: The inspection and maintenance items shown above are to be performed at your Yanmar Marine dealer or distributor.

PERIODIC MAINTENANCE PROCEDURES

WARNING

Exposure Hazard.

ALWAYS wear personal protective equipment when performing periodic maintenance procedures.

Daily Checks

Before you head out for the day, make sure the Yanmar engine is in good operating condition.

NOTICE

It is important to perform the daily checks as listed in this Operation Manual. Periodic maintenance prevents unexpected downtime, reduces the number of accidents due to poor engine performance and helps extend the life of the engine.

Make sure you check the following items.

Visual Checks

1. Check for engine oil leaks.
2. Check for fuel leaks.

WARNING

Piercing Hazard.

Avoid skin contact with the high-pressure diesel fuel spray caused by a fuel system leak, such as a broken fuel injection line.

High-pressure fuel can penetrate your skin and result in serious injury. If you are exposed to high-pressure fuel spray, obtain prompt medical treatment.

NEVER check for a fuel leak with your hands.

ALWAYS use a piece of wood or cardboard. Have your authorized Yanmar Marine dealer or distributor repair any damage.

3. Check for engine coolant leaks.
4. Check for damaged or missing parts.
5. Check for loose, missing or damaged fasteners.
6. Check the electrical harnesses for cracks, abrasions, and damaged or corroded connectors.
7. Check hoses for cracks, abrasions, and damaged, loose or corroded clamps.
8. Check the fuel filter / water separator for presence of water and contaminants. If you find any water or contaminants, drain the fuel filter / water separator. *See Draining Fuel Filter / Water Separator on page 76.* If you have to drain the fuel filter / water separator frequently, drain the fuel tank and check for the presence of water in your fuel supply. *See Draining the Fuel Tank on page 71.*

NOTICE

If any problem is noted during the visual check, the necessary corrective action should be taken before operating the engine.

Check Diesel Fuel, Engine Oil and Engine Coolant Levels

Follow the procedures in *Diesel Fuel on page 34*, *Engine Oil on page 39* and *Engine Coolant on page 42* to check these levels.

Checking and Refilling Marine Gear Oil

Refer to the *Operation Manual* for the marine gear.

Checking the Battery Electrolyte Level

Check the battery electrolyte level before use. **See *Checking the Battery Electrolyte Level (Serviceable Batteries Only)* on page 78.**

Checking the Alternator Belt

Check the belt tension before use. *See **Checking and Adjusting the Alternator V-Belt Tension** on page 73.*

Checking the Remote Control Handle

Check the operation of the remote control handle and ensure it moves smoothly. If it is hard to operate, grease the joints of the remote control cable and lever bearings. If the lever is too loose, adjust the remote control cable. *See **Checking and Adjusting Remote Control Cables** on page 74.*

Checking the Alarm Indicators

When operating the start switch on the instrument panel, check that there is no alarm message on the display and the alarm indicators work normally. *See **Control Equipment** on page 23.*

Preparing Fuel, Oil and Coolant in Reserve

Prepare sufficient fuel for the days operation. Always store engine oil and coolant in reserve (for at least one refill) onboard, to be ready for emergencies.

After Initial 50 Hours of Operation

Perform the following maintenance after the initial 50 hours of operation.

- **Draining the Fuel Tank**
- **Changing the Engine Oil and Replacing the Engine Oil Filter Element**
- **Changing the Marine Gear Oil and Replacing the Marine Gear Oil Filter (If Equipped)**
- **Checking and Adjusting the Alternator V-Belt Tension**
- **Inspecting and Adjusting Intake / Exhaust Valve Clearance**
- **Checking and Adjusting the Remote Control Cables**
- **Adjusting Propeller Shaft Alignment**

Draining the Fuel Tank

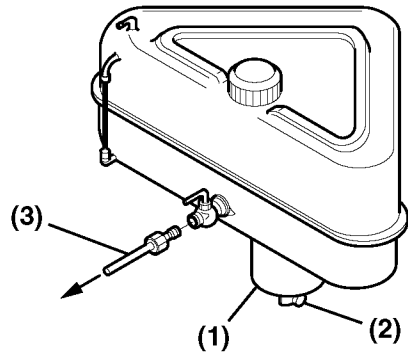

0004542

Figure 1

Note: Optional fuel tank shown. Actual equipment may differ.

PERIODIC MAINTENANCE

1. Put a pan under the drain cock (**Figure 1, (2)**) to catch fuel.
2. Open the drain cock and drain water and sediment. Close the drain cock when the fuel is clean and free of air bubbles.

Changing the Engine Oil and Replacing the Engine Oil Filter Element

The engine oil on a new engine becomes contaminated from the initial break-in of internal parts. It is very important that the initial oil replacement is performed as scheduled.

It is easiest and most available to drain the engine oil after operation while the engine is still warm.

WARNING

Burn Hazard.

If you must drain the engine oil while it is still hot, stay clear of the hot engine oil to avoid being burned. ALWAYS wear eye protection.

1. Turn the engine off.
2. Remove the engine oil dipstick. Attach the oil drain pump (if equipped) and pump out the oil.
For easier draining, remove the engine oil fill cap. Dispose of used oil properly.

NOTICE

- Prevent dirt and debris from contaminating engine oil. Carefully clean the dipstick and the surrounding area before removing the dipstick.
- ALWAYS be environmentally responsible.

3. Remove the engine oil filter (**Figure 2**) with a filter wrench (turn counterclockwise).

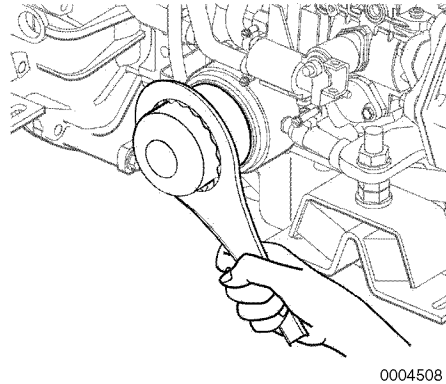

Figure 2

Note: 4JH4-TE shown.

4. Install a new filter element and tighten by hand until the seal touches the housing.
5. Turn filter an additional 3/4 turn clockwise with a box wrench. Tighten to 20 to 24 N·m (177 to 212 in.-lb).
6. Fill with new engine oil. *See Adding Engine Oil on page 40.*

NOTICE

NEVER mix different types of engine oil. This may adversely affect the lubricating properties of the engine oil.
NEVER overfill. Overfilling may result in white exhaust smoke, engine overspeed or internal damage.

7. Perform a trial run and check for oil leaks.
8. Approximately 10 minutes after stopping the engine, remove the oil dipstick and check the oil level. Add oil if the level is too low.

NOTICE

Be careful not to get any oil on the V-belt. Oil on the belt causes slipping and stretching. Replace the belt if it is damaged.

Changing the Marine Gear Oil and Replacing the Marine Gear Oil Filter (If Equipped)

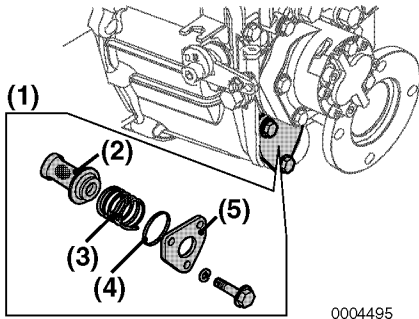

Figure 3

Note: 4JH4-TE / 4JH4-HTE1 / 4JH4-HTE engines with KMH4A marine gear shown. Refer to the Operation Manual for the marine gear or sail drive for procedure.

1. Remove cap from the filler port and attach an oil drain pump. Drain marine gear oil.

NOTICE

ALWAYS be environmentally responsible.

2. KMH4A Marine Gear:

Wash the marine gear oil filter:

- (a) Remove side cover (**Figure 3, (5)**) and remove the filter (**Figure 3, (2)**).
- (b) Clean the filter thoroughly with kerosene or clean diesel fuel.
- (c) Hold the filter in place with the coil spring (**Figure 3, (3)**) and insert into the case. Install a new O-ring (**Figure 3, (4)**) in the side cover.
- (d) Install side cover and tighten side cover bolts.

3. Fill marine gear with clean marine gear oil. See *Marine Gear Oil Specifications* on page 41.

4. Perform a trial run and check for oil leaks.
5. Approximately 10 minutes after stopping the engine, remove the oil dipstick and check the oil level. Add oil if the level is too low.

Checking and Adjusting the Alternator V-Belt Tension

⚠ WARNING

Sever Hazard. Perform this check with the power switch off and the battery switch turned off to avoid contact with moving parts.

NOTICE

- When there is not enough tension in the V-belt, it will slip and the coolant pump will fail to supply coolant. Engine overheating and seizure will result.
- When there is too much tension in the V-belt, the belt will become damaged more quickly and the coolant pump bearing may be damaged.
- NEVER get any oil on the belt(s). Oil on the belt causes slipping and stretching. Replace the belt if it is damaged.

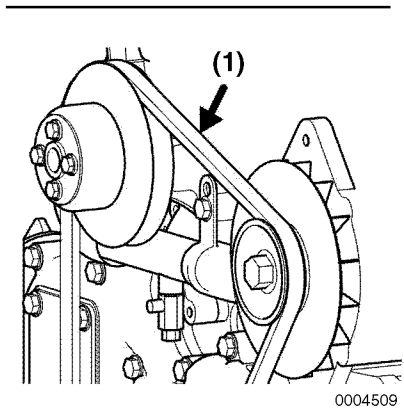

Figure 4

Note: 4JH4-TE shown.

PERIODIC MAINTENANCE

1. Remove the belt cover.
2. Check the belt by pushing on the middle of the belt (**Figure 4, (1)**) with your finger.
With proper tension, the belt should deflect 8 to 10 mm (approximately 3/8 in.).
3. Loosen the alternator bolt and move the alternator to adjust the V-belt tension.
4. Install the belt cover.

Note: If replacing the V-belt, loosen the V-pulley of the coolant pump to remove V-belt.

Inspecting and Adjusting Intake / Exhaust Valve Clearance

Proper adjustment is necessary to maintain the correct timing for opening and closing the valves. Improper adjustment will cause the engine to run noisily, resulting in poor engine performance and engine damage. See your authorized Yanmar Marine dealer or distributor to adjust the intake / exhaust valve clearance.

Checking and Adjusting Remote Control Cables

NOTICE

Never adjust the high-speed stop bolt on the governor. This will void the engine warranty.

Adjusting Engine Speed Remote Control Cable

Ensure the control lever on the engine side moves to the high-speed stop position and low-speed stop position when the remote control lever is moved to HIGH and then to LOW.

3JH5E / 4JH5E

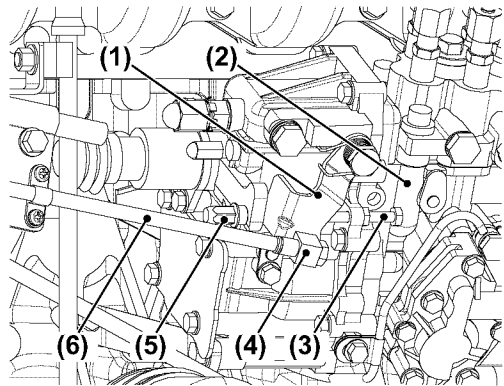

Figure 5

- 1 – Control Lever
- 2 – Fuel Injection Pump
- 3 – Low-Speed Stop
- 4 – Adjustment Screw
- 5 – High-Speed Stop
- 6 – Cable

4JH4-TE / 4JH4-HTE1 / 4JH4-HTE

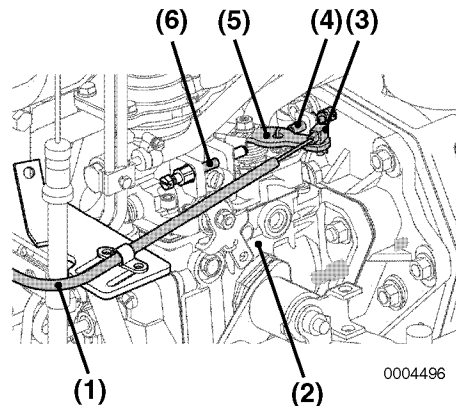

Figure 6

- 1 – Cable
- 2 – Fuel Injection Pump
- 3 – Cable Fitting
- 4 – Low-Speed Stop
- 5 – Control Lever
- 6 – High-Speed Stop

1. To adjust, loosen the adjustment screw (Figure 5, (4)) or cable fitting (Figure 6, (3)) for the remote control cable on the engine side and adjust.
2. Adjust the high-speed stop (Figure 5, (5)) or (Figure 6, (6)) position first and then adjust the low-speed stop (Figure 5, (3)) or (Figure 6, (4)), with the adjustment screw on the remote control lever (Figure 5, (1)) or (Figure 6, (5)).

Adjusting Clutch Remote Control Cable 3JH5E / 4JH5E

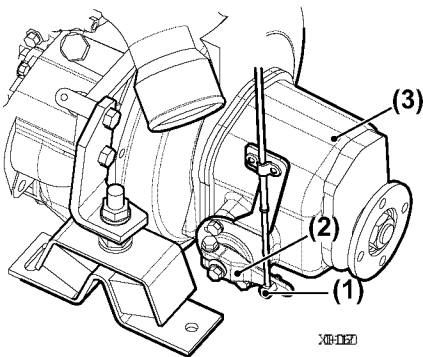

Figure 7

4JH4-TE / 4JH4-HTE1 / 4JH4-HTE

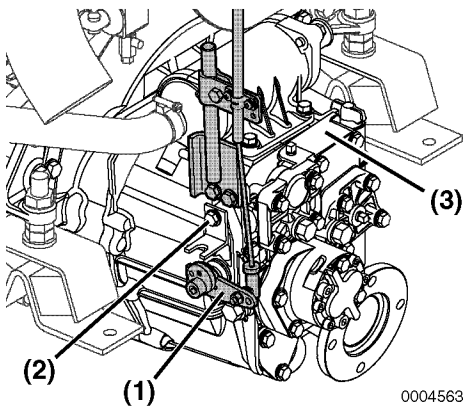

Figure 8

1. Ensure that the remote control lever (Figure 7, (2)) or (Figure 8, (1)) moves to the correct position when the remote control handle is in the NEUTRAL, FORWARD and REVERSE positions. Use the NEUTRAL position as the standard for adjustment.
2. To adjust, loosen and retighten the cable fitting (Figure 7, (1)) or (Figure 8, (2)).

Adjusting Trolling Remote Control Handle - If Equipped

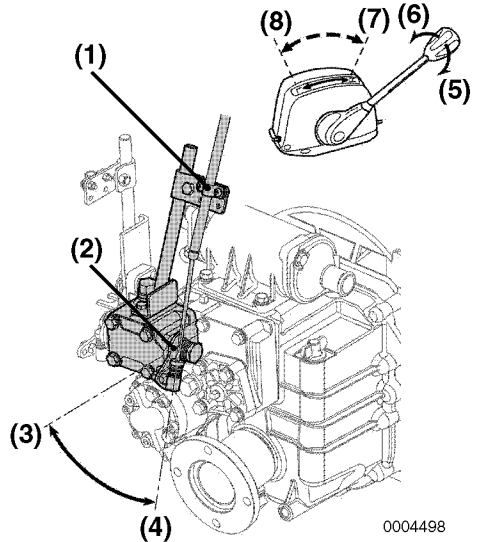

Figure 9

- 1 – Cable Fitting
- 2 – Trolling Lever
- 3 – Low Speed (trolling)
- 4 – High Speed
- 5 – Loosen
- 6 – Tighten
- 7 – Normal Operation (high speed)
- 8 – Trolling (low speed)

Note: KMH4A marine gear shown.

PERIODIC MAINTENANCE

1. Ensure that the trolling lever (**Figure 9, (2)**) is in the high-speed (**Figure 9, (4)**) position when the trolling remote control handle is in high-speed position (**Figure 9, (7)**).
2. Ensure that the trolling lever is in the low-speed (**Figure 9, (3)**) position when the trolling remote control handle is in low-speed position (**Figure 9, (8)**).
3. To adjust, loosen the adjustment screw of the cable fitting (**Figure 9, (1)**) and adjust the position of the cable.

Adjusting Propeller Shaft Alignment

The flexible engine mounts are compressed slightly during initial engine operation and may cause misalignment between the engine and the propeller shaft.

After the first 50 hours of operation, the alignment should be checked and readjusted if necessary. This is considered normal maintenance and the adjustment requires specialized knowledge and techniques. Consult your authorized Yanmar Marine dealer or distributor.

Check for any unusual noise and vibration in the engine / boat hull, while increasing and decreasing the engine speed gradually.

If there is unusual noise and / or vibration, this maintenance requires specialized knowledge and techniques. See your authorized Yanmar Marine dealer or distributor to adjust the propeller shaft alignment.

Every 50 Hours of Operation

Perform the following procedures every 50 hours thereafter or monthly, whichever comes first.

- **Draining Fuel Filter / Water Separator**
- **Checking Battery Electrolyte Level (Serviceable Batteries Only)**

Draining Fuel Filter / Water Separator

WARNING

Fire and Explosion Hazard.

When removing any fuel system component to perform maintenance (such as changing the fuel filter), put an approved container under the opening to catch the fuel.

NEVER use a shop rag to catch the fuel. Vapors from the rag are flammable and explosive. Wipe up any spills immediately.

Exposure Hazard.

Wear eye protection. The fuel system is under pressure and fuel could spray out when removing any fuel system component.

3JH5E and 4JH5E (Attach to Hull)

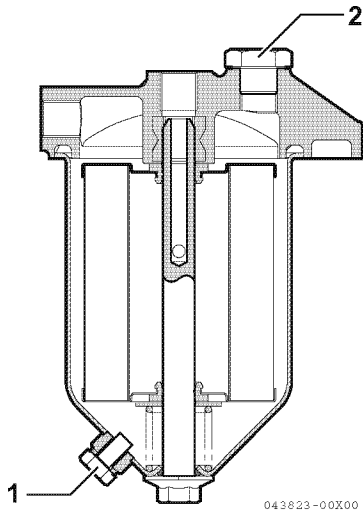

Figure 10

1. Close the fuel tank cock.
2. Loosen the drain plug (**Figure 10, (1)**) of the water separator and drain off any water or dirt collected inside. Dispose of the collected water and dirt properly.

NOTICE

ALWAYS be environmentally responsible.

3. After draining, tighten the air bleed screw (**Figure 10, (2)**).
4. Be sure to bleed air from the fuel system. See *Bleeding the Fuel System* on page 38.

4JH4-TE and 4JH4-HTE1, 4JH4-HTE

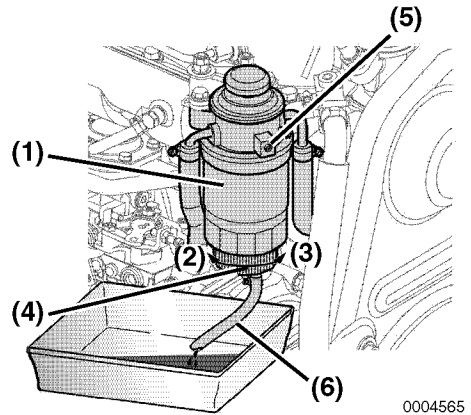

0004565

Figure 11

Note: 4JH4-TE shown.

NOTICE

If the fuel filter / water separator is positioned higher than the fuel level in the fuel tank, water may not drip out when the fuel filter / water separator drain cock is opened. If this happens, turn the air vent screw on the top of the fuel filter / water separator two to three turns counterclockwise. Be sure to tighten the air vent screw after the water has drained out.

1. Close the fuel tank cock.
2. Loosen the hose clamp and remove the fire-resistant cover, which is installed to the lower part of the fuel filter / water separator to protect the water alarm switch.
3. Attach a tube (**Figure 11, (6)**) to the drain plug (**Figure 11, (4)**).

PERIODIC MAINTENANCE

- Loosen the drain plug (**Figure 11, (4)**) at the bottom of the fuel filter / water separator by turning counterclockwise and drain off any water or sediment.

NOTE: If there is a large quantity of water and sediment in the fuel filter / water separator, also drain the fuel tank. See *Draining the Fuel Tank on page 71*.

NOTICE

ALWAYS be environmentally responsible. Dispose of the collected water and dirt properly.

- Tighten the drain plug.
- Remove the drain tube.
- Install the fire-resistant cover and tighten the hose clamp.
- Bleed air from the fuel system. See *Bleeding the Fuel System on page 38*.

Checking the Battery Electrolyte Level (Serviceable Batteries Only)

WARNING

Exposure Hazard. Batteries contain sulfuric acid. NEVER allow battery fluid to come in contact with clothing, skin or eyes. Severe burns could result. ALWAYS wear safety goggles and protective clothing when servicing the battery. If battery fluid contacts the eyes and / or skin, immediately flush the affected area with a large amount of clean water and obtain prompt medical treatment.

NOTICE

NEVER turn off the battery switch (if equipped) or short the battery cables during operation. Damage to the electric system will result.

NEVER operate with insufficient battery electrolyte. Operating with insufficient electrolyte will destroy the battery.

Battery fluid tends to evaporate in high temperatures, especially in summer. In such conditions, inspect the battery earlier than specified.

- Turn off the battery switch (if equipped) or disconnect the negative (-) battery cable.
- Do not operate with insufficient battery electrolyte, as the battery will be destroyed.
- Remove the plugs and check the electrolyte level in all cells.

NOTICE

NEVER attempt to remove the covers or fill a maintenance-free battery.

- If the level is lower than the minimum fill level (**Figure 12, (1)**), fill with distilled water (**Figure 12, (2)**) (available in the grocery store) up to the upper limit (**Figure 12, (3)**) of the battery.

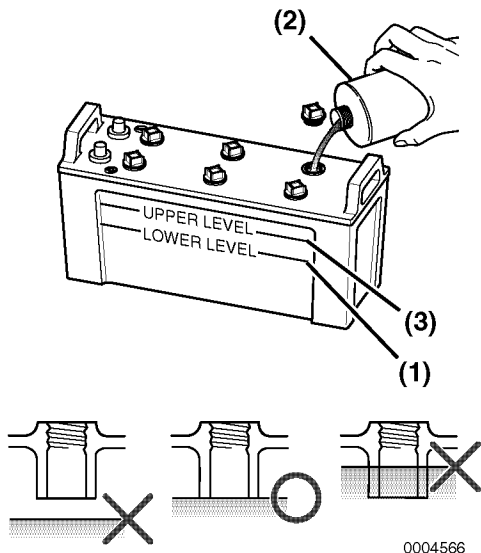

Figure 12

Note: The maximum fill level is approximately 10 to 15 mm (3/8 to 9/16 in.) above the plates.

Every 250 Hours of Operation

Perform the following maintenance every 250 hours or 1 year of operation, whichever comes first.

- Draining the Fuel Tank
- Replacing the Fuel Filter Element
- Changing the Engine Oil and Replacing the Engine Oil Filter Element
- Changing the Marine Gear Oil and Replacing Marine Gear Oil Filter Element (If Equipped)
- Checking or Replacing the Seawater Impeller
- Changing the Coolant
- Cleaning the Intake Silencer (Air Cleaner) Element
- Cleaning the Exhaust / Water Mixing Elbow
- Cleaning the Turbocharger (If Equipped)
- Adjusting the Alternator V-Belt Tension
- Checking the Wiring Connectors
- Tightening All Major Nuts and Bolts

Draining the Fuel Tank

See *Draining the Fuel Tank* on page 71.

PERIODIC MAINTENANCE

Replacing the Fuel Filter Element

⚠ WARNING

Fire and Explosion Hazard.
When removing any fuel system component to perform maintenance (such as changing the fuel filter), put an approved container under the opening to catch the fuel.
NEVER use a shop rag to catch the fuel. Vapors from the rag are flammable and explosive. Wipe up any spills immediately.

Exposure Hazard.
Wear eye protection. The fuel system is under pressure and fuel could spray out when removing any fuel system component.

3JH5E / 4JH5E

When there is not enough tension in the V-belt, it will slip and the coolant pump will fail to supply coolant. Engine overheating and seizure will result.

When there is too much tension in the V-belt, the belt will become damaged more quickly and the coolant pump bearing may be damaged.

⚠ WARNING

Sever Hazard.
Perform this check with the power switch off and the battery switch turned off to avoid contact with moving parts.

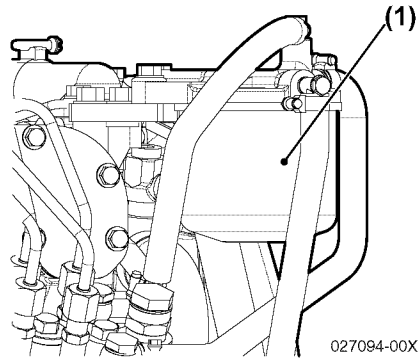

Figure 13

1. Close the fuel tank drain cock.
2. Remove the cartridge filter (**Figure 13, (1)**) with a filter wrench.

Note: When removing the fuel filter, hold the bottom of the fuel filter with a cloth to prevent the fuel from spilling. Wipe up any spilled fuel immediately.

3. Apply a thin film of clean diesel fuel to the sealing surface of the new filter gasket.

Component	Part No.
Fuel Filter - 3JH5E / 4JH5E	119802-55801

4. Install a new filter and hand-tighten. Use a filter wrench and tighten to 20 to 24 N·m (14.75 to 17.7 ft-lb).
5. Bleed the fuel system. See *Bleeding the Fuel System* on page 38. Dispose of waste properly.
6. Check for fuel leaks.

⚠ WARNING

Piercing Hazard.

Avoid skin contact with the high-pressure diesel fuel spray caused by a fuel system leak, such as a broken fuel injection line.

High-pressure fuel can penetrate your skin and result in serious injury. If you are exposed to high-pressure fuel spray, obtain prompt medical treatment.

NEVER check for a fuel leak with your hands.

ALWAYS use a piece of wood or cardboard. Have your authorized Yanmar Marine dealer or distributor repair any damage.

4JH4-TE / 4JH4-HTE1 / 4JH4-HTE

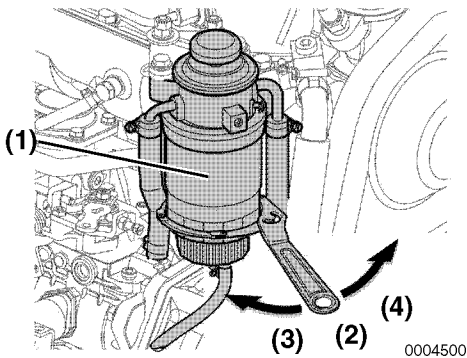

Figure 14

1. Close the fuel tank drain cock.
2. Loosen the hose clamp and remove the fire-resistant cover, which is installed to the lower part of the fuel filter / water separator to protect the water alarm switch.
3. Attach a tube to the drain plug.
4. Loosen the drain plug and drain the fuel from the drain plug.

5. Disconnect the electrical connectors and remove the alarm switch with a spanner wrench.
6. Remove the filter housing (**Figure 14, (1)**) with a filter wrench (**Figure 14, (2)**).
7. Clean the filter housing mounting surface. Install new filter element in filter housing.

Component	Part No.
Fuel Filter - 4JH4-TE / 4JH4-HTE1 / 4JH4-HTE	129574-55711

8. Install the alarm switch to the fuel filter. Apply clean fuel to the gasket of the new fuel filter.
9. Install filter housing into engine and hand-tighten until the gasket comes into contact with the seat. Use a filter wrench and tighten approximately 3/4 turn to 11.8 to 15.6 N·m (104.4 to 138.1 in.-lb).
10. Install the fire-resistant cover and tighten the hose clamp.
11. Bleed the fuel system. *See Bleeding the Fuel System on page 38.*
12. Dispose of waste properly.

PERIODIC MAINTENANCE

Changing the Engine Oil and Replacing the Engine Oil Filter Element

See *Changing the Engine Oil and Replacing the Engine Oil Filter Element* on page 72.

Changing the Marine Gear Oil and Replacing the Marine Gear Oil Filter Element (if equipped)

See *Changing the Marine Gear Oil and Replacing the Marine Gear Oil Filter (If Equipped)* on page 73.

Checking or Replacing Seawater Pump Impeller

1. Loosen side cover bolts and remove the side cover.
2. Inspect the inside of the seawater pump with a flashlight. If any of the following are found, disassembly and maintenance are required:
 - Impeller blades are cracked or nicked. Edges or surfaces of the blades are marred or scratched.
 - Wear plate is damaged.
3. If no damage is found when inspecting the inside of the pump, install the O-ring and side cover.
4. If a large amount of water leaks continuously from the water drain line below the seawater pump during operation, replace the mechanical seal. See your authorized Yanmar Marine dealer or distributor.

Replacing the Seawater Pump Impeller

Note: The impeller must be replaced periodically (every 1000 hours) even if there is no damage.

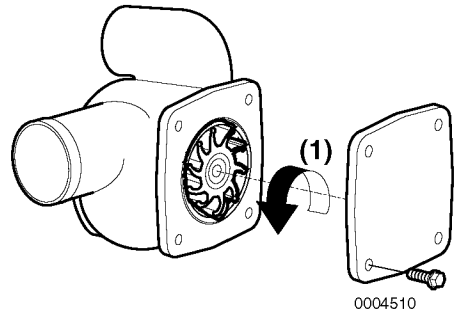

Figure 15

There are two types of special service tools for removing the impeller:

Puller A (standard) Part No. 129671-92110

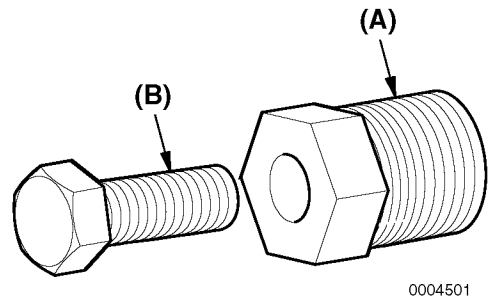

Figure 16

Puller A	Jack Screw B
M18x1.5	M10x40 mm length

1. Remove the side cover of the seawater pump.
2. Install puller (**Figure 16, (A)**) in the impeller.
3. Turn the jack screw (**Figure 16, (B)**) clockwise to remove the impeller from the pump body.

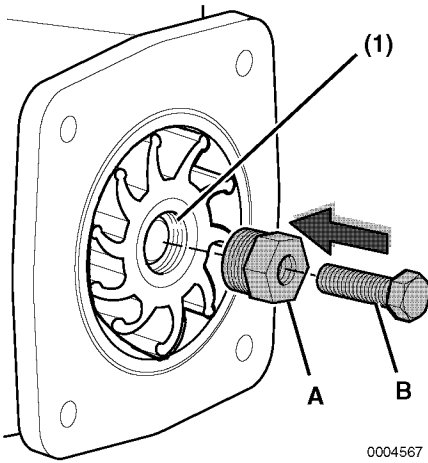

Figure 17

0004567

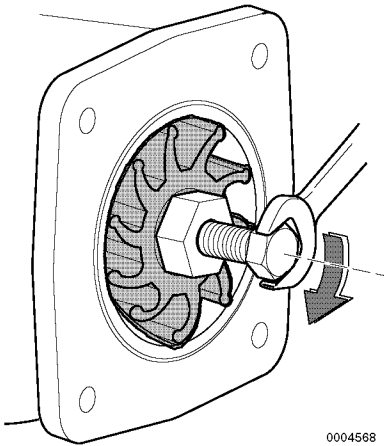

Figure 18

0004568

Note: When replacing a used impeller with a new one, the impeller must have an M18x1.5 thread (Figure 17, (1)). Turn the M18 screw side of the impeller to the cover side and install (Figure 18).

Puller B (option)
Part No. 129671-92100

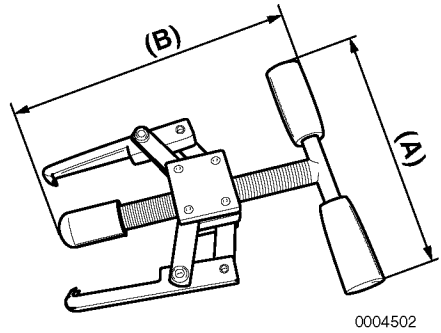

Figure 19

A	B
110 mm (4.33 in.)	140 mm (5.51 in.)

Changing the Coolant

CAUTION

Coolant Hazard. Wear eye protection and rubber gloves when you handle engine coolant. If contact with the eyes or skin should occur, flush eyes and wash immediately with clean water.

Change the coolant every year.

NOTICE

NEVER mix different types and / or colors of coolants.

Discard old coolant in an approved manner according to environmental laws.

Note: If Long Life coolant is used, replace coolant every 2 years.

3JH5E

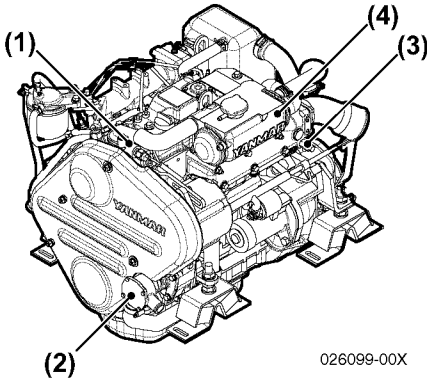

Figure 20

- 1 – Coolant Pump
- 2 – Seawater Drain from Seawater Pump Cover
- 3 – Coolant Drain Cock
- 4 – Coolant Tank (heat exchanger)

4JH5E

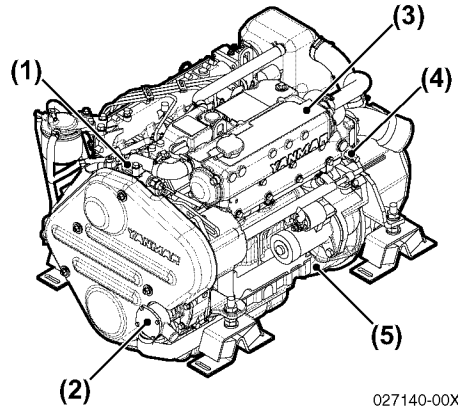

Figure 22

- 1 – Coolant Pump
- 2 – Seawater Drain from Seawater Pump Cover
- 3 – Coolant Tank (heat exchanger)
- 4 – Coolant Drain Cock
- 5 – Flywheel Housing

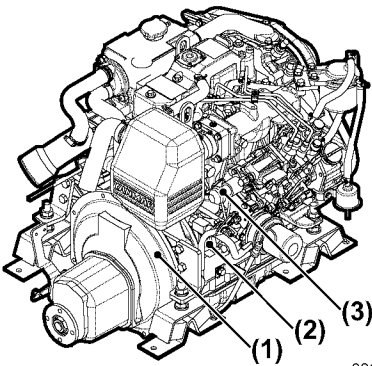

Figure 21

- 1 – Flywheel Housing
- 2 – Coolant Drain Cock
- 3 – Stop Solenoid

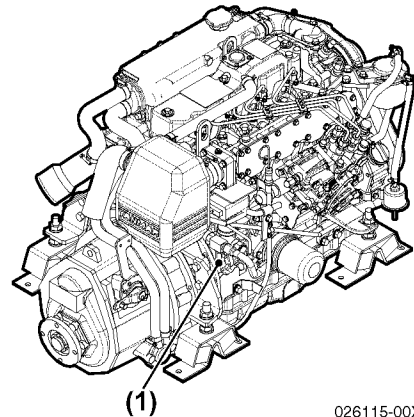
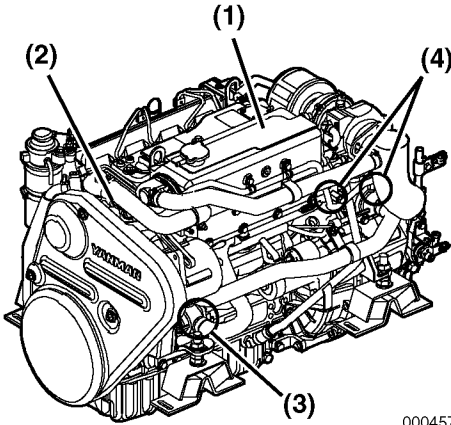

Figure 23

- 1 – Coolant Drain Cock

4JH4-TE



0004571

Figure 24

- 1 – Coolant Tank (heat exchanger)
- 2 – Coolant Pump
- 3 – Seawater Drain from Seawater Pump Cover
- 4 – Coolant Drain Cock (two used)

4JH4-HTE1 / 4JH4-HTE

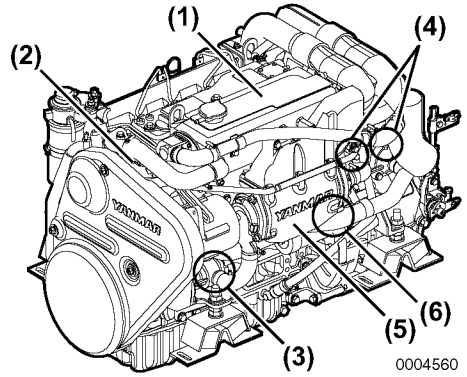

0004560

Figure 26

- 1 – Coolant Tank (heat exchanger)
- 2 – Coolant Pump
- 3 – Seawater Drain from Seawater Pump Cover
- 4 – Coolant Drain Cock
- 5 – Intercooler
- 6 – Seawater Drain from Seawater Pump Cover

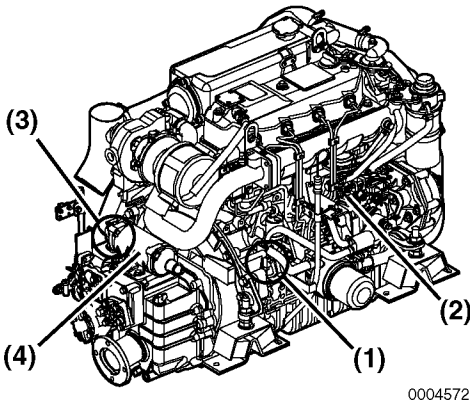

0004572

Figure 25

- 1 – Coolant Drain Cock
- 2 – Fuel Pump
- 3 – Seawater Drain Cock
- 4 – Marine Gear Cooler

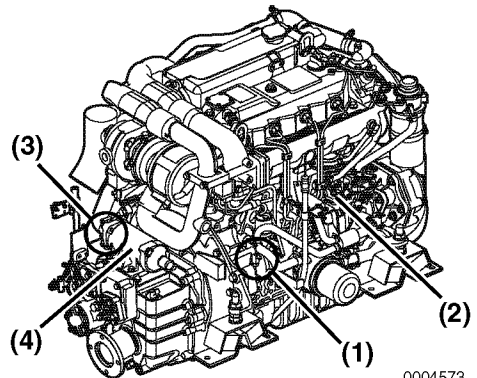

0004573

Figure 27

- 1 – Coolant Drain Cock
- 2 – Fuel Pump
- 3 – Seawater Drain Cock
- 4 – Marine Gear Cooler

PERIODIC MAINTENANCE

Note: The drain cocks are opened before shipping from the factory. Marine gear ZF25A does not have a drain cock on the clutch cooler.

1. Open all coolant drain cocks.
2. Allow to drain completely. Dispose of waste properly.
3. Close all the drain cocks.
4. Fill coolant tank and reservoir with appropriate coolant.
See Engine Coolant Specifications on page 42 and Checking and Adding Coolant on page 43 .

Cleaning the Intake Silencer (Air Cleaner) Element

1. Disassemble the intake silencer (air cleaner).
2. Remove element. Clean element and housing with a neutral detergent.
3. Dry completely and reassemble.

Cleaning the Exhaust / Water Mixing Elbow

The mixing elbow is attached to the turbocharger. The exhaust gas is mixed with seawater in the mixing elbow.

1. Remove the mixing elbow.
2. Clean dirt and scale out of the exhaust and seawater passages.
3. If the mixing elbow is damaged, repair or replace. See your authorized Yanmar Marine dealer or distributor.
4. Inspect the gasket and replace if necessary.

Cleaning the Turbocharger (If Equipped)

Contamination of the turbocharger causes revolutions to drop and engine output to fall.

If a significant drop in engine output is noted (10% or more), clean the turbocharger.

This should be done only by a trained and qualified technician. See your authorized Yanmar Marine dealer or distributor.

Adjusting the Alternator V-Belt Tension

See Checking and Adjusting the Alternator V-Belt Tension on page 73.

Checking the Wiring Connectors

See your authorized Yanmar Marine dealer or distributor.

Tightening All Major Nuts and Bolts

See Tightening Fasteners on page 62 or see your authorized Yanmar Marine dealer or distributor.

Every 500 Hours of Operation

Perform the following maintenance every 500 hours or 2 years of operation, whichever comes first.

- **Replacing the Exhaust / Water Mixing Elbow**
- **Replacing Rubber Hoses**

Replacing the Exhaust / Water Mixing Elbow

Replace the mixing elbow with a new one every 500 hours or 2 years, whichever comes first, even if no damage is found.

See your authorized Yanmar Marine dealer or distributor.

Replacing Rubber Hoses

Replace rubber hoses every 2000 hours or 2 years, whichever comes first.

See your authorized Yanmar Marine dealer or distributor.

Every 1000 Hours of Operation

Perform the following maintenance every 1000 hours or 4 years of operation, whichever comes first.

- **Checking the Fuel Injection Timing**
- **Checking the Fuel Injector Spray Pattern**
- **Replacing the Seawater Pump Impeller**
- **Cleaning and Checking the Seawater Passages**
- **Checking Diaphragm Assembly (3JH5E / 4JH5E Only)**
- **Replacing the Alternator V-Belt**
- **Adjusting Intake / Exhaust Valve Clearance**
- **Checking the Remote Control Cable Operation**
- **Adjusting the Propeller Shaft Alignment**

Checking the Fuel Injection Timing

See your authorized Yanmar Marine dealer or distributor.

Checking the Fuel Injector Spray Pattern

See your authorized Yanmar Marine dealer or distributor.

Replacing the Seawater Pump Impeller

The seawater impeller must be replaced every 1000 hours even if it is not damaged.

See Checking or Replacing Seawater Pump Impeller on page 82.

PERIODIC MAINTENANCE

Cleaning and Checking the Seawater Passages

After prolonged use, clean the seawater passages to remove trash, scale, rust and other contaminants that collect in the cooling water passages. This can cause declining cooling performance. The following items need to be inspected:

- Heat Exchanger
- Pressure Cap

See your authorized Yanmar Marine dealer or distributor.

Checking Diaphragm Assembly (3JH5E / 4JH5E Only)

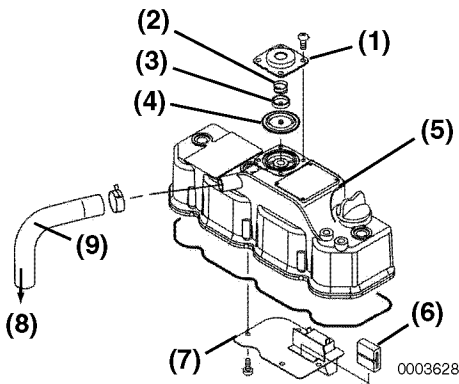

Figure 28

- 1 – Diaphragm Cover
- 2 – Spring
- 3 – Center Plate
- 4 – Diaphragm
- 5 – Rocker Arm Cover
- 6 – Breather Baffle
- 7 – Baffle Plate
- 8 – Intake Silencer
- 9 – Breather Pipe

See your authorized Yanmar Marine dealer or distributor.

Replacing the Alternator V-Belt

See *Checking and Adjusting the Alternator V-Belt Tension* on page 73.

Adjusting Intake / Exhaust Valve Clearance

See your authorized Yanmar Marine dealer or distributor.

Checking the Remote Control Cable Operation

See your authorized Yanmar Marine dealer or distributor.

Adjusting the Propeller Shaft Alignment

See your authorized Yanmar Marine dealer or distributor.

TROUBLESHOOTING

SAFETY PRECAUTIONS

Before performing any troubleshooting procedures within this section, review the *Safety* section on page 5.

If a problem occurs, stop the engine immediately. Refer to the Symptom column in the Troubleshooting Chart to identify the problem.

TROUBLESHOOTING AFTER STARTING

Just after the engine has started, check the following items at a low engine speed:

Is sufficient water being discharged from the seawater outlet pipe?

If the discharge is low, stop the engine immediately. Identify the cause and repair.

Is the smoke color normal?

The continuous emission of black exhaust smoke indicates engine overloading. This shortens the engines life and should be avoided.

Are there abnormal vibrations or noise?

Depending on the hull structure, engine and hull resonance may suddenly increase at certain engine speed ranges, causing heavy vibrations. Avoid operation in this speed range. If any abnormal sounds are heard, stop the engine and inspect for cause.

Alarm sounds during operation.

If the alarm sounds during operation, lower the engine speed immediately, check the alarm lamps and stop the engine for repairs.

TROUBLESHOOTING

Is there water, oil or fuel leakage? Are there any loose bolts or connections?

Check the engine room daily for any leaks or loose connections.

Is there sufficient fuel in the fuel tank?

Refill fuel in advance to avoid running out of fuel. If the tank runs out of fuel, bleed the fuel system. See *Bleeding the Fuel System* on page 38.

When operating the engine at low speed for long periods of time, race the engine once every 2 hours. Racing the engine with the clutch in NEUTRAL, accelerate from the low-speed position to the high-speed position and repeat this process about five times. This is done to clean out carbon from the cylinders and the fuel injection valves.

NOTICE

Neglecting to race the engine will result in poor smoke color and reduce engine performance.

Periodically operate the engine near maximum speed while underway. This will generate higher exhaust temperatures, which will help clean out hard carbon deposits, maintain engine performance and prolong the life of the engine.

TROUBLESHOOTING INFORMATION

If the engine does not operate properly, refer to the *Troubleshooting Chart* on page 91 or see your authorized Yanmar Marine dealer or distributor.

Supply the authorized Yanmar Marine dealer or distributor with the following information:

- Model name and serial number of your engine
- Boat model, hull material, size (tons)
- Use, type of boating, number of hours run
- Total number of operation hours (refer to hourmeter), age of boat
- The operating conditions when the problem occurs:
 - Engine speed (min⁻¹)
 - Color of exhaust smoke
 - Type of diesel fuel
 - Type of engine oil
 - Any abnormal noises or vibration
 - Operating environment such as high altitude or extreme ambient temperatures, etc.
 - Engine maintenance history and previous problems
 - Other factors that contribute to the problem

TROUBLESHOOTING CHART

Symptom	Probable Cause	Measure	Reference
Indicators light on the instrument panel and alarm sounds during operation	Shift to low-speed operation immediately, and check which indicator has come on. Stop the engine and inspect. If no abnormality is identified and there is no problem with operation, return to port at lowest speed and request repairs.		
<ul style="list-style-type: none"> Engine oil low pressure alarm indicator comes on 	Engine oil level is low.	Check engine oil level. Add or replace.	See <i>Checking the Engine Oil</i> on page 40
	Engine oil filter clogged.	Replace engine oil filter. Replace engine oil.	See <i>Changing the Engine Oil and Replacing the Engine Oil Filter Element</i> on page 72
<ul style="list-style-type: none"> Water in sail drive seal indicator comes on 	Rubber sail drive seal broken.	See your authorized Yanmar Marine dealer or distributor.	-
<ul style="list-style-type: none"> Coolant high temperature alarm comes on 	Coolant level is low.	Check coolant level and refill.	See <i>Checking and Adding Coolant</i> on page 43
	Insufficient seawater causing temperature to rise.	Check seawater system.	-
	Contamination inside cooling system.	See your authorized Yanmar Marine dealer or distributor.	-
<ul style="list-style-type: none"> Faulty Warning Devices 	Do not operate the engine if alarm devices are not repaired. Serious accidents may result if abnormalities are not identified due to faulty indicators or alarm.		
Indicators Do Not Go On:			
<ul style="list-style-type: none"> The tachometer does not turn on, even though the power switch is turned on 	No electrical current available. The battery switch is turned off, the fuse (3 A) on the instrument panel is burned out or the circuit is broken.	See your authorized Yanmar Marine dealer or distributor.	-
<ul style="list-style-type: none"> One of the indicators does not go out 	Sensor switch is faulty.	See your authorized Yanmar Marine dealer or distributor.	-
<ul style="list-style-type: none"> Battery low charge indicator does not go out during operation 	V-belt is loose or broken.	Replace V-belt or adjust tension.	See <i>Checking and Adjusting the Alternator V-Belt Tension</i> on page 73
	Battery is defective.	Check battery fluid level, specific gravity or replace battery.	See <i>Checking the Battery Electrolyte Level (Serviceable Batteries Only)</i> on page 78
	Alternator power generation failure.	See your authorized Yanmar Marine dealer or distributor.	-
Starting Failures:			
<ul style="list-style-type: none"> Starter turns but engine does not start 	No fuel.	Add fuel. Bleed fuel system.	See <i>Filling the Fuel Tank</i> on page 37 and <i>Bleeding the Fuel System</i> on page 38
	Fuel filter is clogged.	Replace filter element.	See <i>Replacing the Fuel Filter Element</i> on page 80
	Improper fuel.	Replace with recommended fuel.	See <i>Diesel Fuel Specifications</i> on page 34
	Problem with fuel injection.	See your authorized Yanmar Marine dealer or distributor.	-

TROUBLESHOOTING

Symptom	Probable Cause	Measure	Reference
Compression leakage from intake / exhaust valve.	See your authorized Yanmar Marine dealer or distributor.	-	-
<ul style="list-style-type: none"> Starter does not turn or turns slowly (engine can be turned manually) 	Faulty clutch position.	Shift to NEUTRAL and start.	-
	Insufficient battery charge.	Check fluid level. Recharge. Replace.	See <i>Checking the Battery Electrolyte Level (Serviceable Batteries Only)</i> on page 78
	Cable terminal contact failure.	Remove corrosion from terminals. Tighten battery cables.	-
	Faulty safety switch device.	See your authorized Yanmar Marine dealer or distributor.	-
	Faulty instrument panel.	See your authorized Yanmar Marine dealer or distributor.	-
Power lacking due to accessory drive being engaged.	See your authorized Yanmar Marine dealer or distributor.	-	-
<ul style="list-style-type: none"> Engine cannot be turned manually 	Internal parts seized.	See your authorized Yanmar Marine dealer or distributor.	-
Abnormal Smoke Color:			
<ul style="list-style-type: none"> Black smoke 	Load increased.	See your authorized Yanmar Marine dealer or distributor.	-
	Improper propeller matching.	See your authorized Yanmar Marine dealer or distributor.	-
	Dirty intake silencer (air cleaner).	Clean element.	See <i>Cleaning the Intake Silencer (Air Cleaner) Element</i> on page 86
	Improper fuel.	Replace with recommended fuel.	See <i>Diesel Fuel Specifications</i> on page 34
	Faulty spraying of fuel injector.	See your authorized Yanmar Marine dealer or distributor.	-
<ul style="list-style-type: none"> Incorrect intake / exhaust valve clearance. 	See your authorized Yanmar Marine dealer or distributor.	-	-
<ul style="list-style-type: none"> White smoke 	Improper fuel.	Replace with recommended fuel.	See <i>Diesel Fuel Specifications</i> on page 34
	Faulty spraying of fuel injector.	See your authorized Yanmar Marine dealer or distributor.	-
	Fuel injection timing off.	See your authorized Yanmar Marine dealer or distributor.	-
	Engine burning oil (excessive consumption).	See your authorized Yanmar Marine dealer or distributor.	-

LONG-TERM STORAGE

If the engine will not be used for an extended period of time, special measures should be taken to protect the cooling system, fuel system and combustion chamber from corrosion and the exterior from rusting.

The engine can normally stand idle for up to 6 months. If it remains unused for longer than this, please contact your authorized Yanmar Marine dealer or distributor.

Before performing any storage procedures within this section, review the *Safety* section on page 5.

In cold temperatures or before long-term storage, be sure to drain the seawater from the cooling system.

NOTICE

DO NOT drain the coolant system. A full coolant system will prevent corrosion and frost damage.

If seawater is left inside of the engine, it may freeze and damage parts of the cooling system when the ambient temperature is below 0°C (32°F).

PREPARE ENGINE FOR LONG-TERM STORAGE

Note: If the engine is close to a periodic maintenance interval, perform those maintenance procedures before putting the engine into long-term storage.

1. Wipe off any dust or oil from the outside of engine.
2. Drain water from fuel filters.
3. Drain fuel tank completely or fill the tank to prevent condensation.
4. Grease the exposed areas and joints of the remote control cables and the bearings of the remote control handle.
5. Seal the intake silencer, exhaust pipe, etc. to prevent moisture or contamination from entering engine.
6. Completely drain bilge in hull bottom.
7. Waterproof the engine room to prevent rain or seawater from entering.
8. Charge the battery once a month to compensate for battery's self-discharge.
9. Make sure the power switch is off.

**DRAIN SEAWATER
COOLING SYSTEM**

3JH5E

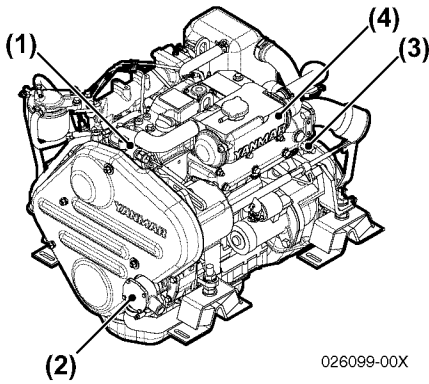

026099-00X

Figure 1

- 1 – Coolant Pump
- 2 – Seawater Drain from Seawater Pump Cover
- 3 – Coolant Drain Cock
- 4 – Coolant Tank (heat exchanger)

4JH5E

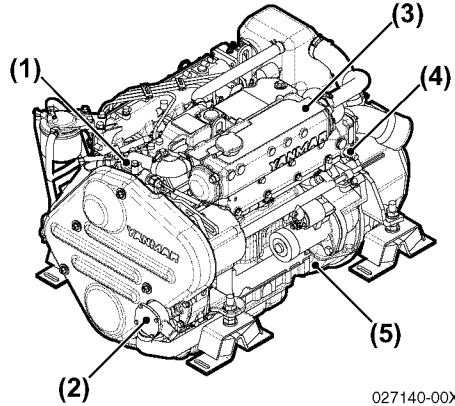

027140-00X

Figure 3

- 1 – Coolant Pump
- 2 – Seawater Drain from Seawater Pump Cover
- 3 – Coolant Tank (heat exchanger)
- 4 – Coolant Drain Cock
- 5 – Flywheel Housing

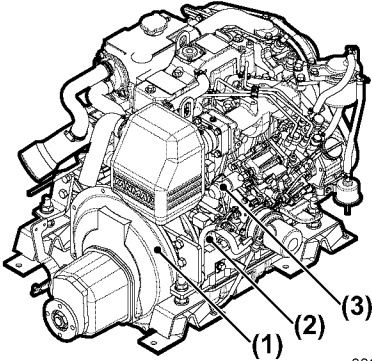

026100-00X

Figure 2

- 1 – Flywheel Housing
- 2 – Coolant Drain Cock
- 3 – Stop Solenoid

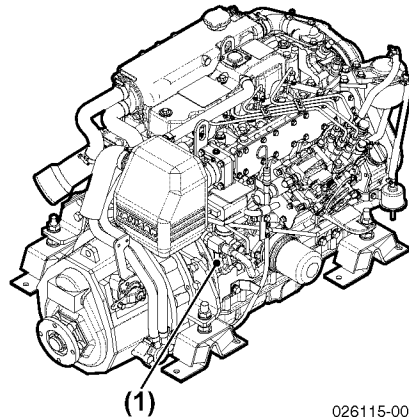

026115-00X

Figure 4

- 1 – Coolant Drain Cock

4JH4-TE

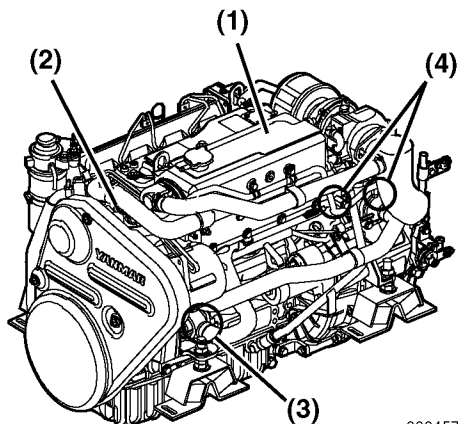

0004571

Figure 5

- 1 – Coolant Tank (heat exchanger)
- 2 – Coolant Pump
- 3 – Seawater Drain from Seawater Pump Cover
- 4 – Coolant Drain Cock (two used)

4JH4-HTE1 / 4JH4-HTE

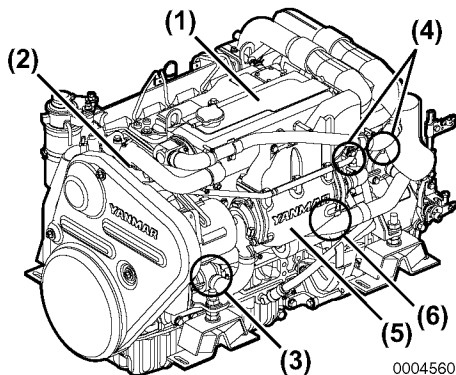

0004560

Figure 7

- 1 – Coolant Tank (heat exchanger)
- 2 – Coolant Pump
- 3 – Seawater Drain from Seawater Pump Cover
- 4 – Coolant Drain Cock
- 5 – Intercooler
- 6 – Seawater Drain from Heat Exchanger

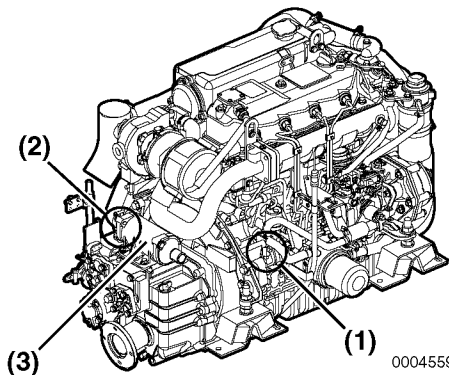

0004559

Figure 6

- 1 – Coolant Drain Cock
- 2 – Seawater Drain Cock
- 3 – Marine Gear Cooler

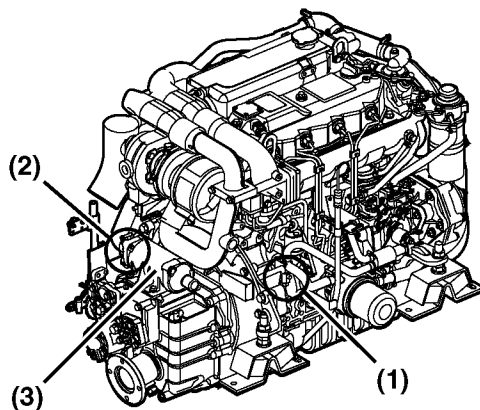

0004561

Figure 8

- 1 – Coolant Drain Cock
- 2 – Seawater Drain Cock
- 3 – Marine Gear Cooler

Note: The drain cocks are opened before shipping from the factory. Marine gear ZF25A does not have a drain cock on the clutch cooler.

NOTICE

If seawater is left inside, it may freeze and damage parts of the cooling system (heat exchanger, seawater pump, etc.) when ambient temperature is below 32°F (0°C).

1. Open the seawater drain cock on the clutch cooler (if equipped). Allow to drain. Open the seawater drain cock on the intercooler (4JH4-HTE1, 4JH4-HTE only) and drain. If no water drains, use a stiff brush to remove any debris.
2. Remove four bolts attaching the side cover of the seawater pump. Remove the cover and drain the seawater.
3. Install cover and tighten bolts.
4. Close all the drain cocks.

RETURNING THE ENGINE TO SERVICE

1. Replace the oil and the oil filter before running the engine.
2. Supply fuel if the fuel in the fuel tank was removed, and prime the fuel system.
3. Confirm that there is engine coolant in the engine.
4. Operate the engine at idle speed for 1 minute.
5. Check fluid levels and check engine for leaks.

SPECIFICATIONS

PRINCIPAL ENGINE SPECIFICATIONS

SPECIFICATIONS

3JH5E Engine

Specification		3JH5E			
		KM35P	KM35A	SD50	Bobtail
Use		Pleasure use			
Type		Vertical water cooled 4-cycle diesel engine			
Combustion System		Direct injection			
Air Charging		Natural aspiration			
Number of Cylinders		3			
Bore x Stroke		88 mm x 90 mm (3.46 in. x 3.54 in.)			
Displacement		1.642 L (100.20 cu in.)			
Continuous Output		26.1 kW (35.5 hp metric) / 2900 min ⁻¹			
Maximum Output Rating	Output at crankshaft / engine speed	28.7 kW (39.0 hp metric) / 3000 min ^{-1*}			
	Output at propeller / engine speed	27.4 kW (37.3 hp metric) / 3000 min ^{-1**}	-	-	-
Installation		Flexible mounting			
Fuel Injection Timing		FIR 5 ± 1° BTDC (at Maximum Rated Output Power) FIT 18 ± 1° BTDC (at Plunger Lift 2.5 mm [0.098 in.])			
Fuel Injection Opening Pressure		21.6 to 21.7 MPa			
Main Power Take Off		At flywheel end			
Direction of Rotation	Crankshaft	Counterclockwise viewed from stern			
	Propeller shaft (ahead)	Clockwise viewed from stern	-	-	-
Cooling System		Coolant cooling with heat exchanger			
Lubrication System		Forced lubrication system			
Cooling Water Capacity (fresh)		Engine 4.5 L (4.8 qt), Reservoir: 0.8 L (0.8 qt)			
Lubricating Oil Capacity (engine)	Rake angle	at rake angle 8°	at rake angle 0°	8° or 0°	
	Total**	5.0 ± 0.3 L (5.3 ± 0.3 qt)	5.5 ± 0.3 L (5.8 ± 0.3 qt)	Refer to left	
	Oil pan only	4.5 ± 0.3 L (4.8 ± 0.3 qt)	5.0 ± 0.3 L (5.3 ± 0.3 qt)	Refer to left	
	Effective***	1.1 L (1.2 qt)	1.2 L (1.3 qt)	Refer to left	
Starting System	Type	Electric			
	Starting motor	DC 12 V - 1.4 kW			
	AC generator	12 V - 80 A			
Engine Dimension	Overall length	777 mm (30.6 in.)	776 mm (30.6 in.)	700 mm (27.6 in.)	
	Overall width	560 mm (22.0 in.)			
	Overall height	623 mm (24.5 in.)			
Flywheel Major Dimension		D300 x 66 mm (11.8 x 2.6 in.)			
Engine Dry Mass (including marine gear)		185 kg (408 lb)	186 kg (410 lb)	213 kg (470 lb) engine: 173 kg (381 lb)	173 kg (381 lb)

* Rating Condition: Temperature of fuel; 40°C at fuel pump inlet; ISO 8665

** The "total" oil quantity includes oil in oil pan, channels, coolers and filter.

*** The effective amount of oil shows the difference in maximum scale of the dipstick and minimum scale.

Note: Density of fuel: 0.842g/cm³ at 15°C. Fuel temperature at the inlet of the fuel injection pump.

Note: 1 hp metric = 0.7355 kW

3JH5E Marine Gears

Model	KM35P	KM35A	SD50 (coupled at boat builder)
Type	Mechanical cone clutch		
Reduction Ratio (forward / reverse)	2.36 / 3.16, 2.61 / 3.16	2.33 / 3.04, 2.64 / 3.04	2.32
Propeller Speed (forward / reverse)*	1232 / 921, 1114 / 921 min ⁻¹	1246 / 955, 1103 / 955 min ⁻¹	1253 min ⁻¹
Lubrication System	Splash	Splash	Oil bath
Lubricating Oil Capacity (total)	0.5 L (0.5 qt)	0.65 L (0.69 qt)	SD50: 2.1 L (2.2 qt) Long Reach (58): 2.35 L (2.48 qt) Long Reach (100): 2.45 L (2.59 qt)
Lubricating Oil Capacity (effective)	0.05 L (0.05 qt)	0.15 L (0.16 qt)	-
Cooling System	Air cooling by fan on flywheel		-
Weight	12 kg (26.5 lb)	13 kg (28.7 lb)	40 kg (88 lb)

* At continuous power engine speed 2907 min⁻¹

SPECIFICATIONS

4JH5E Engine

Engine Model		4JH5E			
Marine Gear Model		KM35P	ZF30M	KM35A2	KM4A1
Use		Pleasure use			
Type		Vertical water cooled 4-cycle diesel engine			
Combustion System		Direct injection			
Air Charging		Natural aspiration			
Number of Cylinders		4			
Bore x Stroke		88 mm x 90 mm (3.46 in. x 3.54 in.)			
Displacement		2.190 L (133.64 cu in.)			
Continuous Output Rating at Crankshaft		36.0 kW (48.9 hp metric) / 2907 min ⁻¹			
Maximum Output Rating	Output at crankshaft / engine speed	39.6 kW (53.8 hp metric) / 3000 min ⁻¹ *			
	Output at propeller / engine speed	38.0 kW (51.7 hp metric) / 3000 min ⁻¹	-	-	-
Installation		Flexible mounting			
Fuel Injection Timing at Max Power		FIR 6.0 ± 1° BTDC (at Fuel Stop Power) FIT 20.0 ± 1° BTDC (at Plunger Lift 2.5 mm [0.098 in.]			
Fuel Injection Opening Pressure		21.6 to 22.6 MPa			
Main Power Take Off		At flywheel end			
Direction of Rotation	Crankshaft	Counterclockwise viewed from stern			
	Propeller shaft (ahead)	Clockwise viewed from stern			
Cooling System		Coolant cooling with heat exchanger			
Lubrication System		Forced lubrication system			
Cooling Water Capacity (fresh)		Engine 6.0 L (6.3 qt) Reservoir: 0.8 L (0.8 qt)			
Lubricating Oil Capacity (engine)	Rake angle	at rake angle 8°		at rake angle 0°	
	Total**	5.0 ± 0.3 L (5.3 ± 0.3 qt)		5.5 ± 0.3 L (5.8 ± 0.3 qt)	
	Oil pan only	4.5 ± 0.3 L (4.8 ± 0.3 qt)		5.0 ± 0.3 L (5.3 ± 0.3 qt)	
	Effective***	1.2 L (1.3 qt)		1.4 L (1.5 qt)	
Starting System	Type	Electric			
	Starting motor	DC 12 V - 1.4 kW			
	AC generator	12 V - 80 A			
Engine Dimension	Overall length	871 mm (34.3 in.)	950 mm (37.4 in.)	864 mm (34.0 in.)	922 mm (36.3 in.)
	Overall width	560 mm (22.0 in.)			
	Overall height	625 mm (24.6 in.)			
Flywheel Major Dimension		D300 x 66 mm (11.8 x 2.6 in.)			
Engine Dry Mass (include marine gear)		213 kg (470 lb)	229 kg (505 lb)	214 kg (472 lb)	230 kg (507 lb)

* Rating Condition: Temperature of fuel; 40°C at fuel pump inlet; ISO 8665

** The "total" oil quantity includes oil in oil pan, channels, coolers and filter.

*** The effective amount of oil shows the difference in maximum scale of the dipstick and minimum scale.

Note: Density of fuel: 0.842g/cm³ at 15°C. Fuel temperature at the inlet of the fuel injection pump.

Note: 1 hp metric = 0.7355 kW

4JH5E (Continued)

Engine Model		4JH5E	
Marine Gear Model		SD50	Bobtail
Use		Pleasure use	
Type		Vertical water cooled 4-cycle diesel engine	
Combustion System		Direct injection	
Air Charging		Natural aspiration	
Number of Cylinders		4	
Bore x Stroke		88 x 90 mm (3.46 x 3.54 in.)	
Displacement		2.190 L 133.6 cu in.	
Continuous Output Rating at Crankshaft		36.0 kW (48.9 hp)/2907 min ⁻¹	
Maximum Output Rating	Output at crankshaft / engine speed	39.6 kW (53.8hp)/3000 min ⁻¹ *	
	Output at propeller / engine speed	-	
Installation		Flexible mounting	
Fuel Injection Timing		FIR 6 ± 1° BTDC (at Fuel Stop Power) FIT 20.0 ± 1° BTDC (at Plunger Lift 2.5 mm [0.098 in.]	
Fuel Injection Pressure		21.6 to 22.6 MPa	
Main Power Take Off		At flywheel end	
Direction of Rotation	Crankshaft	Counterclockwise viewed from stern	
	Propeller shaft (Ahead)	Clockwise viewed from stern	
Cooling System		Coolant cooling with heat exchanger	
Lubrication System		Forced lubrication system	
Cooling Water Capacity (fresh)		Engine 6.0 L (6.3 qt) Reservoir: 0.8 L (0.8 qt)	
Lubricating Oil Capacity (engine)	Rake angle	at rake angle 0°	8° or 0°
	Total **	5.5 ± 0.3 L (5.8 ± 0.3 qt)	Refer to left and page 100
	Oil pan only	5.0 ± 0.3 L (5.3 ± 0.3 qt)	Refer to left and page 100
	Effective ***	1.4 L (1.5 qt)	Refer to left and page 100
Starting System	Type	Electric	
	Starting motor	DC 12 V - 1.4 kW	
	AC generator	12 V - 80 A	
Engine Dimension	Overall length	795 mm (31.3 in.)	
	Overall width	560 mm (22.0 in.)	
	Overall height	625 mm (24.6 in.)	
Flywheel Major Dimension		D300 x 66 mm (11.8 x 2.6 in.)	
Engine Dry Mass (include marine gear)		241 kg (531 lb) engine: 201 kg (443 lb)	201 kg (443 lb)

* Rating Condition: Temperature of fuel; 40°C at fuel pump inlet; ISO 8665

** The "total" oil quantity includes oil in oil pan, channels, coolers and filter.

*** The effective amount of oil shows the difference in maximum scale of the dipstick and minimum scale.

Note: Density of fuel: 0.842g/cm³ at 15°C. Fuel temperature at the inlet of the fuel injection pump.

Note: 1 hp metric = 0.7355 kW

SPECIFICATIONS

4JH5E Marine Gear or Sail Drive

Model	KM35P		ZF30M	
Type	Mechanical cone clutch		Mechanical wet maliple disk clutch	
Reduction Ratio (forward / reverse)	2.36 / 3.16	2.61 / 3.16	2.15 / 2.64	2.70 / 2.64
Propeller Speed (forward / reverse) *	1232 / 921 min ⁻¹	1114 / 921 min ⁻¹	1353 / 1103 min ⁻¹	1078 / 1103 min ⁻¹
Lubrication System	Splash			
Lubricating Oil Capacity (total)	0.5 L (0.5 qt)		1.1 L (1.2 qt) **	
Lubricating Oil Capacity (effective)	0.05 L (0.05 qt)		0.2 L (0.2 qt)	
Cooling System	Air cooling by fan		Seawater cooling	
Weight	12 kg (26 lb)		27.5 kg (61 lb)	

* At continuous power engine speed 2907 min⁻¹

** ZF30M Lubricating oil: ATF

Model	KM35A2		KM4A1			SD50 (coupled at boat builder)
Type	Mechanical cone clutch					
Reduction Ratio (forward / reverse)	2.33 / 3.06	2.64 / 3.06	1.47 / 1.47	2.14 / 2.14	2.63 / 2.63	2.32
Propeller Speed (forward / reverse) *	1246 / 950 min ⁻¹	1103 / 950 min ⁻¹	1983 / 1983 min ⁻¹	1360 / 1360 min ⁻¹	1106 / 1106 min ⁻¹	1253 min ⁻¹
Lubrication System	Splash		Centrifugal pump			Oil bath
Lubricating Oil Capacity (total)	0.65 L (0.69 qt)		2.3 L (2.4 qt)			SD50: 2.1 L (2.2 qt)
Lubricating Oil Capacity (effective)	0.15 L (0.16 qt)		0.20 L (0.21 qt)			-
Cooling System	Air cooling by fan		Seawater cooling			-
Weight	13 kg (28 lb)		29 kg (64 lb)			40 kg (88 lb)

* At continuous power engine speed 2907 min⁻¹

4JH4-TE Engine

Engine Model		4JH4-TE					
Marine Gear Model		ZF30M	KM4A2	KMH4A	ZF25A	SD50-4T	Bobtail
Use		Pleasure use					
Type		Vertical water cooled 4-cycle diesel engine					
Combustion System		Direct injection					
Air Charging		Turbocharged					
Number of Cylinders		4					
Bore x Stroke		84 x 90 mm (3.31 x 3.54 in.)					
Displacement		1.995 L (121.74 cu in.)					
Continuous Output Rating at Crankshaft		50.2 kW (68.3 hp metric) / 3101 min ⁻¹ Rating Condition: *					
Maximum Output Rating	Output at crankshaft / engine speed	55.2 kW (75.1hp metric) / 3200 min ⁻¹ *					
	Output at propeller / engine speed	53.0 kW (72.1hp metric) / 3200 min ⁻¹ *				-	
Installation		Flexible mounting					
Fuel Injection Timing		Plunger lift at TDC 1.26 ± 0.01 mm (when W-CSD is released)					
Fuel Injection Opening Pressure		21.6 ± 0.5 MPa					
Main Power Take Off		At flywheel end					
Direction of Rotation	Crankshaft	Counterclockwise viewed from stern					
	Propeller shaft (Ahead)	Clockwise from stern	Clockwise or counterclockwise (Bi-rotation)			-	
Cooling System		Coolant cooling with heat exchanger					
Lubrication System		Forced lubrication system					
Cooling Water Capacity (fresh)		Engine: 7.2 L (7.6 qt), Reservoir: 0.8 L (0.8 qt)					
Lubricating Oil Capacity (engine)	Rake angle	7°	0°				7° or 0°
	Total **	5.7 ± 0.3 L (6.0 ± 0.3 qt)	6.9 ± 0.3 L (7.3 ± 0.3 qt)				Refer to left
	Oil pan only	5.2 ± 0.3 L (5.5 ± 0.3 qt)	6.4 ± 0.3 L (6.8 ± 0.3 qt)				Refer to left
	Effective ***	2.4 L (2.5 qt)					
Starting System	Type	Electric					
	Starting motor	DC 12 V - 1.4 kW					
	AC generator	12 V - 80 A (12 V - 60 A optional)					
Engine Dimension	Overall length	923 mm (36.3 in.)	903 mm (35.6 in.)	933 mm (36.7 in.)	1017 mm (40.0 in.)	782 mm (30.8 in.)	782 mm (30.8 in.)
	Overall width	616 mm (24.3 in.)					
	Overall height	659 mm (25.9 in.)					
Flywheel Major Dimension		D339 x 66 mm (13.3 x 2.6 in.)					
Engine Dry Mass (including marine gear)		235 kg (518 lb)	237 kg (523 lb)	238 kg (525 lb)	237 kg (523 lb) engine: 207 kg (456 lb)	249 kg (549 lb) engine: 207 kg (456 lb)	207 kg (456 lb)

* Temperature of fuel; 40°C at fuel pump inlet; ISO 8665

** The "total" oil quantity includes oil in oil pan, channels, coolers and filter.

*** The effective amount of oil shows the difference in maximum scale of the dipstick and minimum scale.

Note: Density of fuel: 0.842g/cm³ at 15°C. Fuel temperature at the inlet of the fuel injection pump.

Note: 1 hp metric = 0.7355 kW

SPECIFICATIONS

4JH4-HTE1 Engine

Engine Model		4JH4-HTE1				
Marine Gear Model		ZF30M	KM4A2	KMH4A	ZF25A	Bobtail
Use		Pleasure use				
Type		Vertical water cooled 4-cycle diesel engine				
Combustion System		Direct injection				
Air Charging		Turbocharged				
Number of Cylinders		4				
Bore x Stroke		84 x 90 mm (3.31 x 3.54 in.)				
Displacement		1.995 L (121.74 cu in.)				
Continuous Output Rating at Crankshaft		65.1 kW (88.5 hp metric) / 3101 min ⁻¹ *				
Maximum Output Rating	Output at crankshaft / engine speed	71.6 kW (97.3 hp metric) / 3200 min ⁻¹ *				
	Output at propeller / engine speed	68.7 kW (93.4 hp metric) / 3200 min ⁻¹ *				-
Installation		Flexible mounting				
Fuel Injection Timing		Plunger lift at TDC 1.26 ± 0.01 mm (when W-CSD is released)				
Fuel Injection Opening Pressure		21.6 ± 0.5 MPa				
Main Power Take Off		At flywheel end				
Direction of Rotation	Crankshaft	Counterclockwise viewed from stern				
	Propeller shaft (Ahead)	Clockwise from stern	Clockwise or counterclockwise (Bi-rotation)			-
Cooling System		Coolant cooling with heat exchanger				
Lubrication System		Forced lubrication system				
Cooling Water Capacity (fresh)		Engine: 7.2 L (7.6 qt), Reservoir: 0.8 L (0.8 qt)				
Lubricating Oil Capacity (engine)	Rake angle	7°	0°			7° or 0°
	Total **	5.7 ± 0.3 L (6.0 ± 0.3 qt)	6.9 ± 0.3 L (7.3 ± 0.3 qt)			Refer to left
	Oil pan only	5.2 ± 0.3 L (5.5 ± 0.3 qt)	6.4 ± 0.3 L (6.8 ± 0.3 qt)			Refer to left
	Effective ***	2.4 L (2.5 qt)				
Starting System	Type	Electric				
	Starting motor	DC 12 V - 1.4 kW				
	AC generator	12 V - 80 A (12 V - 60 A optional)				
Engine Dimension	Overall length	923 mm (36.3 in.)	903 mm (35.6 in.)	933 mm (36.7 in.)	1017 mm (40.0 in.)	782 mm (30.8 in.)
	Overall width	616 mm (24.3 in.)				
	Overall height	659 mm (25.9 in.)				
Flywheel Major Dimension		D339 x 66 mm (13.3 x 2.6 in.)				
Engine Dry Mass (including marine gear)		245 kg (540 lb)	247 kg (545 lb)	248 kg (547 lb)	247 kg (545 lb)	217 kg (478 lb)

* Rating Condition: Temperature of fuel; 40°C at fuel pump inlet; ISO 8665

** The "total" oil quantity includes oil in oil pan, channels, coolers and filter.

*** The effective amount of oil shows the difference in maximum scale of the dipstick and minimum scale.

Note: Density of fuel: 0.842g/cm³ at 15°C. Fuel temperature at the inlet of the fuel injection pump.

Note: 1 hp metric = 0.7355 kW

4JH4-HTE Engine

Engine Model		4JH4-HTE				
Marine Gear Model		ZF30M	KM4A2	KMH4A	ZF25A	Bobtail
Use		Pleasure use				
Type		Vertical water cooled 4-cycle diesel engine				
Combustion System		Direct injection				
Air Charging		Turbocharged				
Number of Cylinders		4				
Bore x Stroke		84 x 90 mm (3.31 x 3.54 in.)				
Displacement		1.995 L (121.74 cu in.)				
Continuous Output Rating at Crankshaft		73.6 kW (100 hp metric) / 3101 min ⁻¹ *				
Maximum Output Rating	Output at crankshaft / engine speed	80.9 kW (110 hp metric) / 3200 min ⁻¹ *				
	Output at propeller / engine speed	77.7 kW (106 hp metric) / 3200 min ⁻¹ *				-
Installation		Flexible mounting				
Fuel Injection Timing		Plunger lift at TDC 1.26 ± 0.01 mm (when W-CSD is released)				
Fuel Injection Opening Pressure		21.6 ± 0.5 MPa				
Main Power Take Off		At flywheel end				
Direction of Rotation	Crankshaft	Counterclockwise viewed from stern				
	Propeller shaft (Ahead)	Clockwise from stern	Clockwise or counterclockwise (Bi-rotation)			-
Cooling System		Coolant cooling with heat exchanger				
Lubrication System		Forced lubrication system				
Cooling Water Capacity (fresh)		Engine: 7.2 L (7.6 qt), Reservoir: 0.8 L (0.8 qt)				
Lubricating Oil Capacity (engine)	Rake angle	7°	0°			7° or 0°
	Total **	5.7 ± 0.3 L (6.0 ± 0.3 qt)	6.9 ± 0.3 L (7.3 ± 0.3 qt)			Refer to left
	Oil pan only	5.2 ± 0.3 L (5.5 ± 0.3 qt)	6.4 ± 0.3 L (6.8 ± 0.3 qt)			Refer to left
	Effective ***	2.4 L (2.5 qt)				
Starting System	Type	Electric				
	Starting motor	DC 12 V - 1.4 kW				
	AC generator	12 V - 80 A (12 V - 60 A optional)				
Engine Dimension	Overall length	923 mm (36.3 in.)	903 mm (35.6 in.)	933 mm (36.7 in.)	1017 mm (40.0 in.)	782 mm (30.8 in.)
	Overall width	616 mm (24.3 in.)				
	Overall height	659 mm (25.9 in.)				
Flywheel Major Dimension		D339 x 66 mm (13.3 x 2.6 in.)				
Engine Dry Mass (including marine gear)		245 kg (540 lb)	247 kg (545 lb)	248 kg (547 lb)	247 kg (545 lb)	217 kg (478 lb)

* Rating Condition: Temperature of fuel; 40°C at fuel pump inlet; ISO 8665

** The "total" oil quantity includes oil in oil pan, channels, coolers and filter.

*** The effective amount of oil shows the difference in maximum scale of the dipstick and minimum scale.

Note: *Density of fuel: 0.842g/cm³ at 15°C. Fuel temperature at the inlet of the fuel injection pump.*

Note: *1 hp metric = 0.7355 kW.*

Note: Since 2012, the 4JH4-HTE is not covered by the EPA regulation.

SPECIFICATIONS







4JH4-TE, 4JH4-HTE1 and 4JH4-HTE Marine Gear or Sail Drive

Model	ZF30M		KM4A2			KMH4A		ZF25A		SD50-4T (coupled at boat builder)
Down Angle	0°		7°			8°		8°		-
Type	Mechanical wet multiple disk clutch		Mechanical cone clutch			Hydraulic wet multiple disk clutch		Hydraulic wet multiple disk clutch		Mechanical cone clutch
Reduction Ratio (forward / reverse)	2.15 / 2.64	2.70 / 2.64	1.47 / 1.47	2.14 / 2.14	2.63 / 2.63	2.04 / 2.04	2.45 / 2.45	1.93 / 1.93	2.48 / 2.48	2.32
Propeller Speed (forward / reverse) (min ⁻¹) *	1444 / 1176	1150 / 1176	2115 / 2113	1451 / 1450	1180 / 1179	1520 / 1520	1263 / 1263	1607 / 1607	1250 / 1250	1337
Lubrication System	Splash		Centrifugal pump			Trochoid pump		Trochoid pump		Oil bath
Lubrication Oil	ATF		API CD or higher SAE #20 or #30				ATF		Quick-Silver [®] only	
Lubricating Oil Capacity (total)	1.1 L (1.2 qt)		3.3 L (3.5 qt)			2.0 L (2.1 qt)		1.8 L (1.9 qt)		2.1 L (2.2 qt)
Lubricating Oil Capacity (effective)	0.2 L (0.2 qt)		0.3 L (0.3 qt)			0.2 L (0.2 qt)		-		-
Cooling: System	Seawater cooling									-
Weight	27.5 kg (61 lb)		30 kg (66 lb)			31 kg (68 lb)		30 kg (66 lb)		42 kg (93 lb)

* At continuous power engine speed 2907 min⁻¹

SYSTEM DIAGRAMS

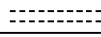
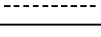
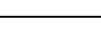
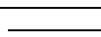
PIPING DIAGRAMS

Notation	Description
	Screw Joint (Union)
	Flange Joint
	Eye Joint
	Insertion Joint
	Drilled Hole
	Coolant Piping
	Cooling Seawater Piping
	Lubricating Oil Piping
	Diesel Fuel Piping

Note:

- Dimension of steel pipe: outer diameter x thickness.
- Dimension of rubber pipe: inner diameter x thickness.
- Fuel rubber pipes (marked *) satisfy EN / ISO7840.

3JH5E with KM35P, KM35A Marine Gear

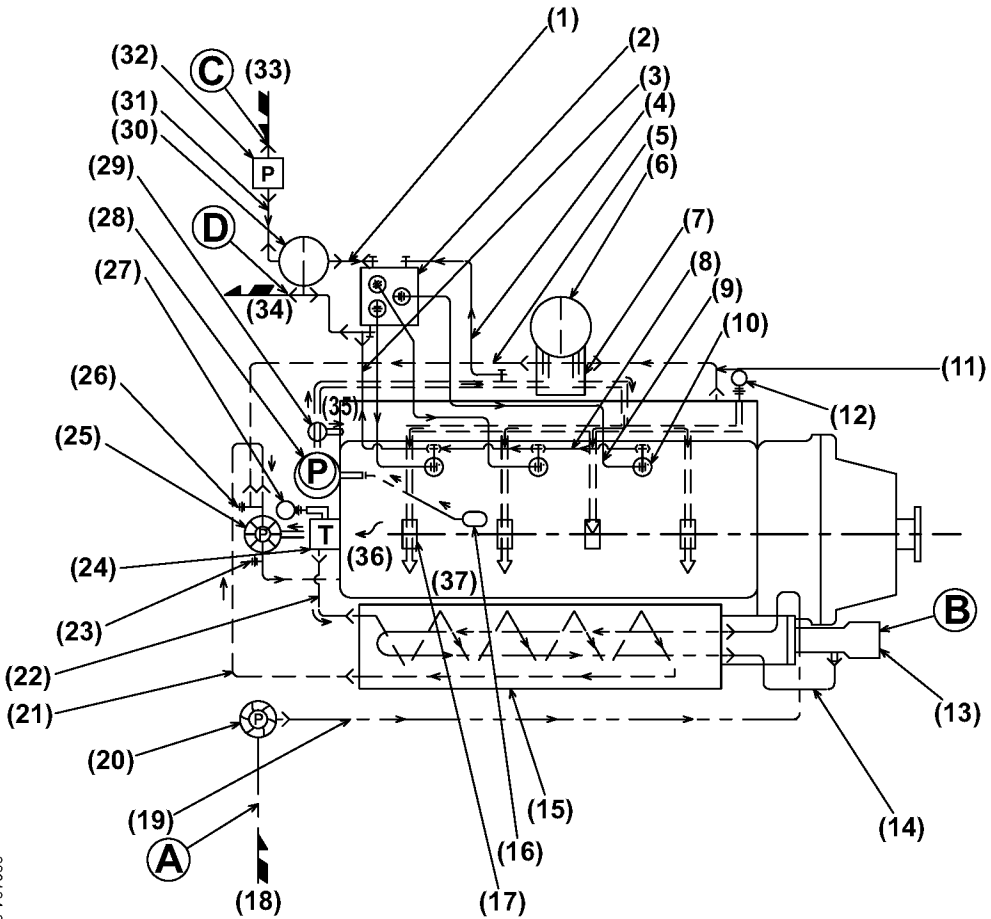
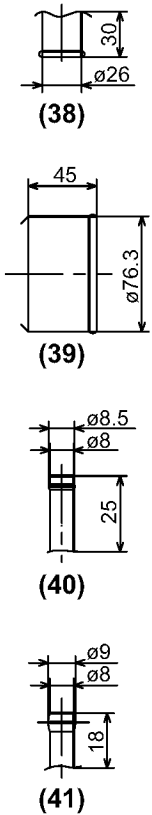

Figure 1

026104-00X

- 1 – * 7 x t4.5 Rubber Hose
- 2 – Fuel Injection Pump
- 3 – * 5 x t4.5 Rubber Hose
- 4 – * 4.76 x t0.7 Steel Pipe
- 5 – * 9 x t3.5 Rubber Hose
- 6 – Lubricating Oil Filter (cartridge type)
- 7 – Lubricating Oil Cooler
- 8 – * 5 x t4.5 Rubber Hose
- 9 – Fuel High-Pressure Pipe 6.35 x t2.375 Steel Pipe
- 10 – Fuel Injection Nozzle
- 11 – 9 x t3.5 Rubber Hose
- 12 – Oil Pressure Switch
- 13 – Mixing Elbow
- 14 – 25.4 x t4.3 Rubber Hose
- 15 – Heat Exchanger
- 16 – Lubricating Oil Inlet Filter
- 17 – Main Bearing
- 18 – Seawater Inlet
- 19 – 25.4 x t4.3 Rubber Hose
- 20 – Cooling Water Pump (seawater)
- 21 – 28 x t4 Rubber Hose
- 22 – 28 x t4 Rubber Hose
- 23 – Hot Water Connection Outlet (R3/8)
- 24 – Thermostat
- 25 – Coolant Pump (fresh water)
- 26 – Hot Water Connection Inlet (R3/8)
- 27 – Coolant Temperature Switch
- 28 – Lubricating Oil Pump
- 29 – Pressure Control Valve
- 30 – Fuel Filter (cartridge type)
- 31 – * 7 x t4.5 Rubber Hose
- 32 – Fuel Feed Pump
- 33 – Fuel Inlet
- 34 – Fuel Overflow
- 35 – To Oil Pan
- 36 – From Cylinder Head
- 37 – To Camshaft
- 38 – Detail of Part A
- 39 – Detail of Part B
- 40 – Detail of Part C
- 41 – Detail of Part D

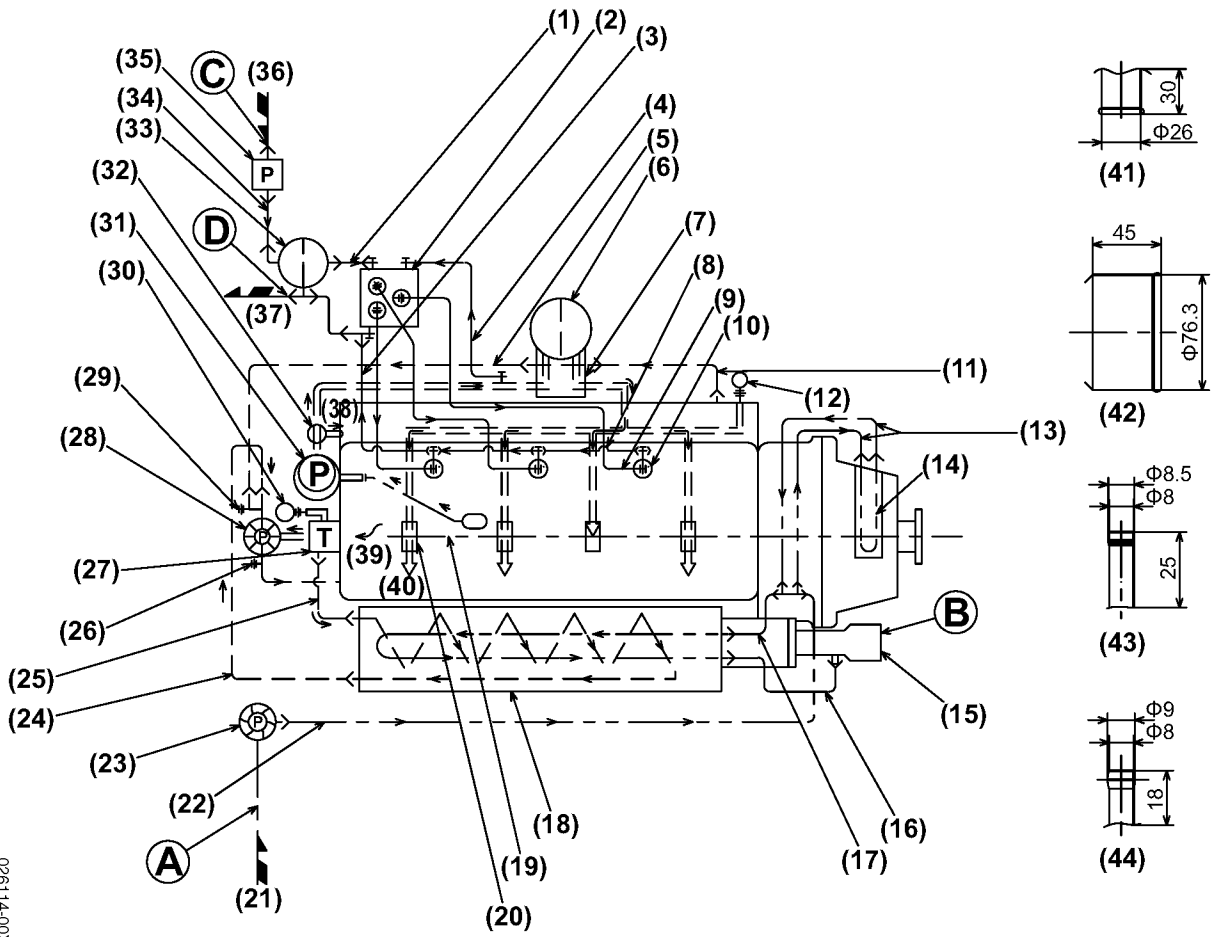

Figure 2

026114-00X

- 1 – * 7 x t4.5 Rubber Hose
- 2 – Fuel Injection Pump
- 3 – * 5 x t4.5 Rubber Hose
- 4 – 4.76 x 0.7 Steel Pipe
- 5 – 9 x t3.5 Rubber Hose
- 6 – Lubricating Oil Filter (cartridge type)
- 7 – Lubricating Oil Cooler
- 8 – * 5 x t4.5 Rubber Hose
- 9 – Fuel High-Pressure Pipe 6.35 x t2.375 Steel Pipe
- 10 – Fuel Injection Nozzle
- 11 – 9 x t3.5 Rubber Hose
- 12 – Oil Pressure Switch
- 13 – 13 x t4 Rubber Hose
- 14 – Clutch Lubricating Oil Cooler
- 15 – Mixing Elbow
- 16 – 25.4 x t4.3 Rubber Hose
- 17 – 25.4 x t4.3 Rubber Hose
- 18 – Heat Exchanger
- 19 – Lubricating Oil Inlet Filter
- 20 – Main Bearing
- 21 – Seawater Inlet
- 22 – 25.4 x t4.3 Rubber Hose
- 23 – Cooling Water Pump (seawater)
- 24 – 28 x t4 Rubber Hose
- 25 – 28 x t4 Rubber Hose
- 26 – Hot Water Connection Outlet (R3/8)
- 27 – Thermostat
- 28 – Coolant Pump (fresh water)
- 29 – Hot Water Connection Inlet (R3/8)
- 30 – Coolant Temperature Switch
- 31 – Lubricating Oil Pump
- 32 – Pressure Control Valve
- 33 – Fuel Filter (cartridge type)
- 34 – * 7 x t4.5 Rubber Hose
- 35 – Fuel Feed Pump
- 36 – Fuel Inlet
- 37 – Fuel Overflow
- 38 – To Oil Pan
- 39 – From Cylinder Head
- 40 – To Camshaft
- 41 – Detail of Part A
- 42 – Detail of Part B
- 43 – Detail of Part C
- 44 – Detail of Part D

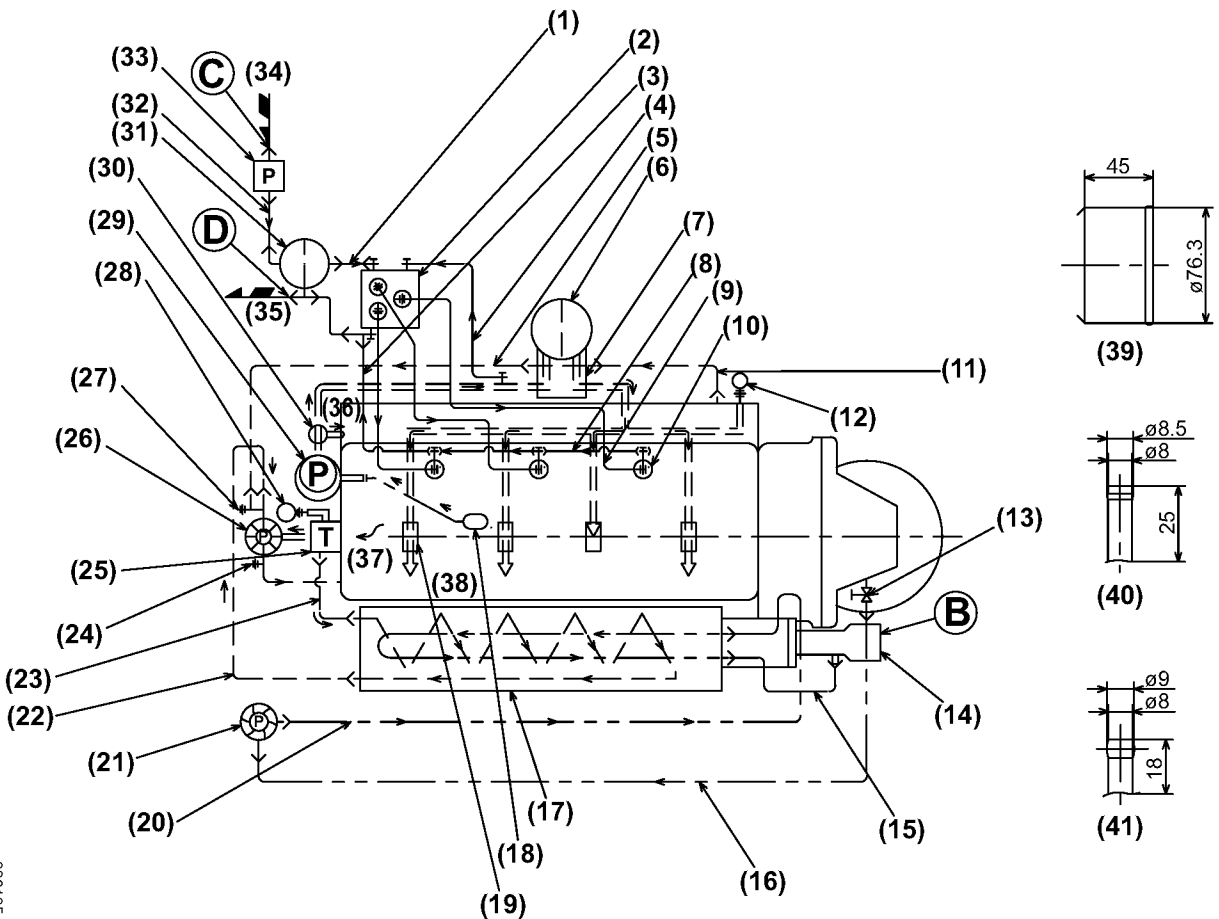
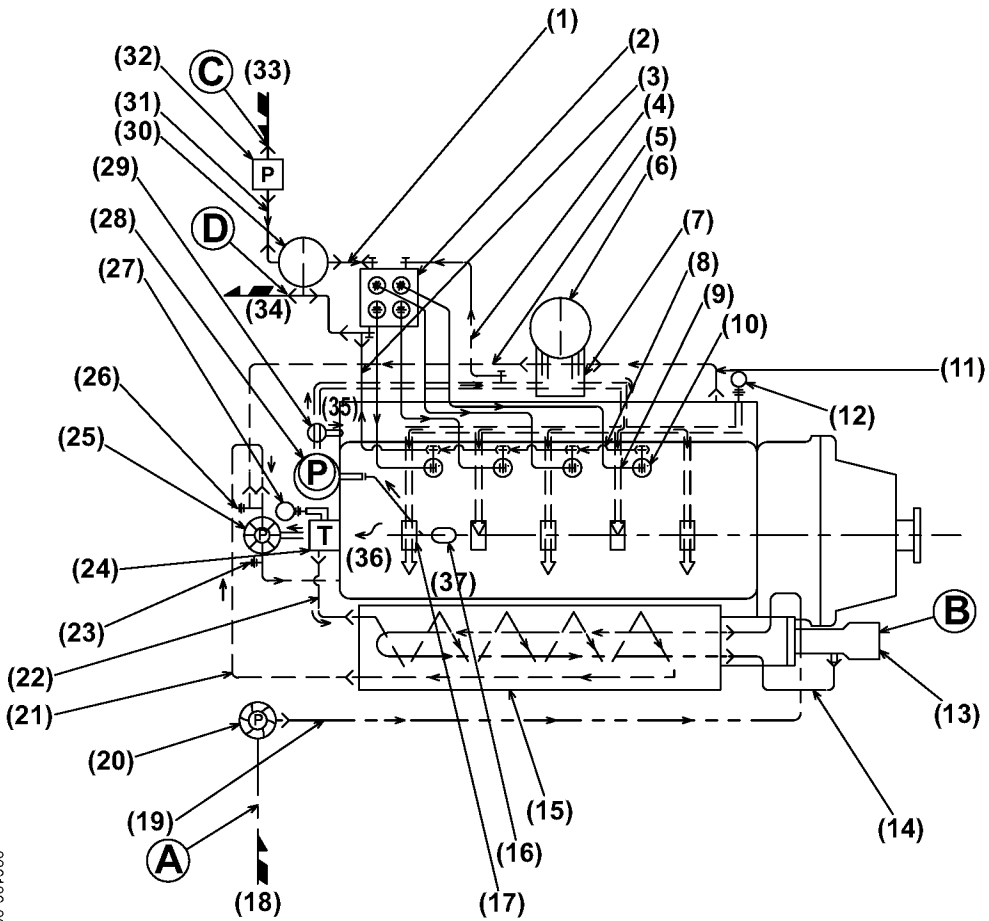
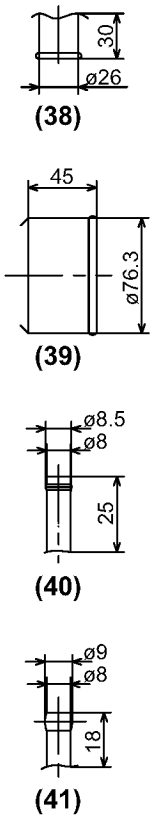

Figure 3

026105-00X

- 1 – * 7 x t4.5 Rubber Hose
- 2 – Fuel Injection Pump
- 3 – * 5 x t4.5 Rubber Hose
- 4 – 4.76 x t0.7 Steel Pipe
- 5 – * 9 x t3.5 Rubber Hose
- 6 – Lubricating Oil Filter (cartridge type)
- 7 – Lubricating Oil Cooler
- 8 – * 5 x t4.5 Rubber Hose
- 9 – Fuel High-Pressure Pipe 6.35 x t2.375 Steel Pipe
- 10 – Fuel Injection Nozzle
- 11 – 9 x t3.5 Rubber Hose
- 12 – Oil Pressure Switch
- 13 – Cock (seawater inlet)
- 14 – Mixing Elbow
- 15 – 25.4 x t4.3 Rubber Hose
- 16 – 25.4 x t4.3 Rubber Hose
- 17 – Heat Exchanger
- 18 – Lubricating Oil Inlet Filter
- 19 – Main Bearing
- 20 – 25.4 x t4.3 Rubber Hose
- 21 – Cooling Water Pump (seawater)
- 22 – 28 x t4 Rubber Hose
- 23 – 28 x t4 Rubber Hose
- 24 – Hot Water Connection Outlet (R3/8)
- 25 – Thermostat
- 26 – Coolant Pump (fresh water)
- 27 – Hot Water Connection Inlet (R3/8)
- 28 – Coolant Temperature Switch
- 29 – Lubricating Oil Pump
- 30 – Pressure Control Valve
- 31 – Fuel Filter (cartridge type)
- 32 – * 7 x t4.5 Rubber Hose
- 33 – Fuel Feed Pump
- 34 – Fuel Inlet
- 35 – Fuel Overflow
- 36 – To Oil Pan
- 37 – From Cylinder Head
- 38 – To Camshaft
- 39 – Detail of Part B
- 40 – Detail of Part C
- 41 – Detail of Part D

4JH5E with KM35P, KM35A2 Marine Gear



026106-00X

Figure 4

- 1 – * 7 x t4.5 Rubber Hose
- 2 – Fuel Injection Pump
- 3 – * 5 x t4.5 Rubber Hose
- 4 – 4.76 x t0.7 Steel Pipe
- 5 – 9 x t3.5 Rubber Hose
- 6 – Lubricating Oil Filter (cartridge type)
- 7 – Lubricating Oil Cooler
- 8 – * 5 x t4.5 Rubber Hose
- 9 – Fuel High-Pressure Pipe 6.35 x t2.375 Steel Pipe
- 10 – Fuel Injection Nozzle
- 11 – 9 x t3.5 Rubber Hose
- 12 – Oil Pressure Switch
- 13 – Mixing Elbow
- 14 – 25.4 x t4.3 Rubber Hose
- 15 – Heat Exchanger
- 16 – Lubricating Oil Inlet Filter
- 17 – Main Bearing
- 18 – Seawater Inlet
- 19 – 25.4 x t4.3 Rubber Hose
- 20 – Cooling Water Pump (seawater)
- 21 – 28 x t4 Rubber Hose
- 22 – 28 x t4 Rubber Hose
- 23 – Hot Water Connection Outlet (R3/8)
- 24 – Thermostat
- 25 – Coolant Pump (fresh water)
- 26 – Hot Water Connection Inlet (R3/8)
- 27 – Coolant Temperature Switch
- 28 – Lubricating Oil Pump
- 29 – Pressure Control Valve
- 30 – Fuel Filter (cartridge type)
- 31 – * 7 x t4.5 Rubber Hose
- 32 – Fuel Feed Pump
- 33 – Fuel Inlet
- 34 – Fuel Overflow
- 35 – To Oil Pan
- 36 – From Cylinder Head
- 37 – To Camshaft
- 38 – Detail of Part A
- 39 – Detail of Part B
- 40 – Detail of Part C
- 41 – Detail of Part D

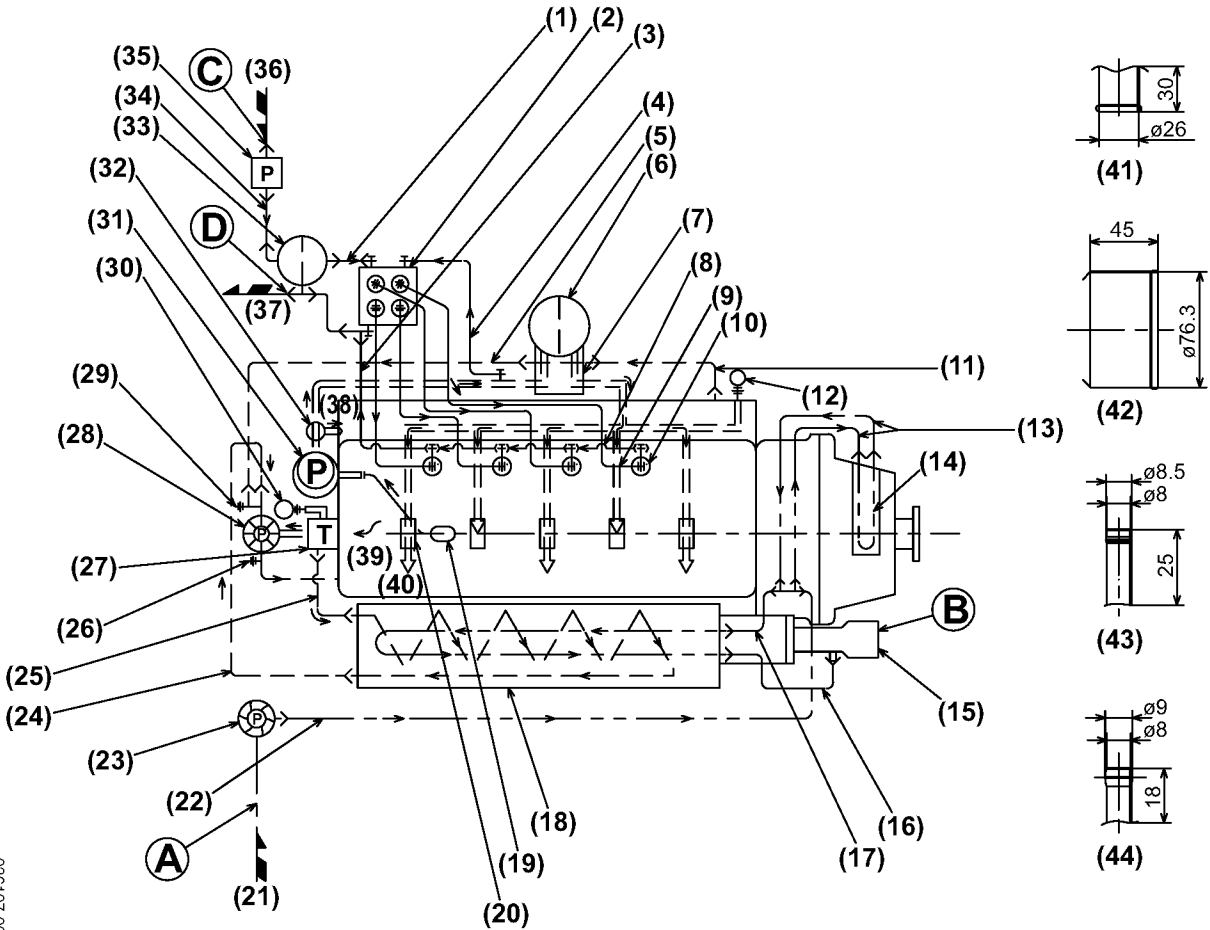
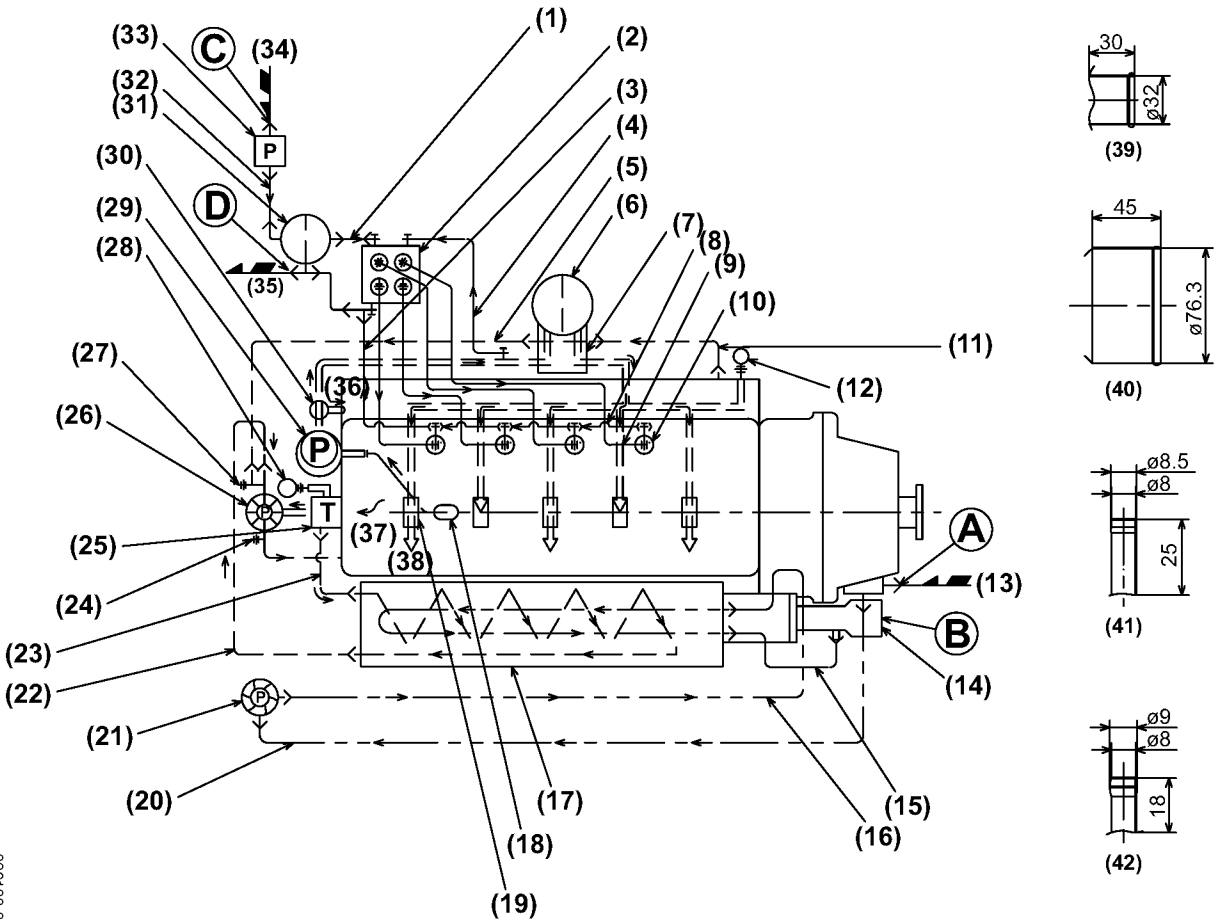

Figure 5

026107-00X

- 1 – * 7 x t4.5 Rubber Hose
- 2 – Fuel Injection Pump
- 3 – * 5 x t4.5 Rubber Hose
- 4 – 4.76 x 0.7 Steel Pipe
- 5 – 9 x t3.5 Rubber Hose
- 6 – Lubricating Oil Filter (cartridge type)
- 7 – Lubricating Oil Cooler
- 8 – * 5 x t4.5 Rubber Hose
- 9 – Fuel High-Pressure Pipe 6.35 x t2.375 Steel Pipe
- 10 – Fuel Injection Nozzle
- 11 – 9 x t3.5 Rubber Hose
- 12 – Oil Pressure Switch
- 13 – 13 x t4 Rubber Hose
- 14 – Clutch Lubricating Oil Cooler
- 15 – Mixing Elbow
- 16 – 25.4 x t4.3 Rubber Hose
- 17 – 25.4 x t4.3 Rubber Hose
- 18 – Heat Exchanger
- 19 – Lubricating Oil Inlet Filter
- 20 – Main Bearing
- 21 – Seawater Inlet
- 22 – 25.4 x t4.3 Rubber Hose
- 23 – Cooling Water Pump (seawater)
- 24 – 28 x t4 Rubber Hose
- 25 – 28 x t4 Rubber Hose
- 26 – Hot Water Connection Outlet (R3/8)
- 27 – Thermostat
- 28 – Coolant Pump (fresh water)
- 29 – Hot Water Connection Inlet (R3/8)
- 30 – Coolant Temperature Switch
- 31 – Lubricating Oil Pump
- 32 – Pressure Control Valve
- 33 – Fuel Filter (cartridge type)
- 34 – * 7 x t4.5 Rubber Hose
- 35 – Fuel Feed Pump
- 36 – Fuel Inlet
- 37 – Fuel Overflow
- 38 – To Oil Pan
- 39 – From Cylinder Head
- 40 – To Camshaft
- 41 – Detail of Part A
- 42 – Detail of Part B
- 43 – Detail of Part C
- 44 – Detail of Part D



- 1 – * 7 x t4.5 Rubber Hose
- 2 – Fuel Injection Pump
- 3 – * 5 x t4.5 Rubber Hose
- 4 – 4.76 x t0.7 Steel Pipe
- 5 – 9 x t3.5 Rubber Hose
- 6 – Lubricating Oil Filter (cartridge type)
- 7 – Lubricating Oil Cooler
- 8 – * 5 x t4.5 Rubber Hose
- 9 – Fuel High-Pressure Pipe 6.35 x t2.375 Steel Pipe
- 10 – Fuel Injection Nozzle
- 11 – 9 x t3.5 Rubber Hose
- 12 – Oil Pressure Switch
- 13 – Seawater Inlet
- 14 – Mixing Elbow
- 15 – 25.4 x t4.3 Rubber Hose
- 16 – 25.4 x t4.3 Rubber Hose
- 17 – Heat Exchanger
- 18 – Lubricating Oil Inlet Filter
- 19 – Main Bearing
- 20 – 25.4 x t4.3 Rubber Hose
- 21 – Cooling Water Pump (seawater)
- 22 – 28 x t4 Rubber Hose
- 23 – 28 x t4 Rubber Hose
- 24 – Hot Water Connection Outlet (R3/8)
- 25 – Thermostat
- 26 – Coolant Pump (fresh water)
- 27 – Hot Water Connection Inlet (R3/8)
- 28 – Coolant Temperature Switch
- 29 – Lubricating Oil Pump
- 30 – Pressure Control Valve
- 31 – Fuel Filter (cartridge type)
- 32 – * 7 x t4.5 Rubber Hose
- 33 – Fuel Feed Pump
- 34 – Fuel Inlet
- 35 – Fuel Overflow
- 36 – To Oil Pan
- 37 – From Cylinder Head
- 38 – To Camshaft
- 39 – Detail of Part A
- 40 – Detail of Part B
- 41 – Detail of Part C
- 42 – Detail of Part D

4JH5E with SD50 Sail Drive

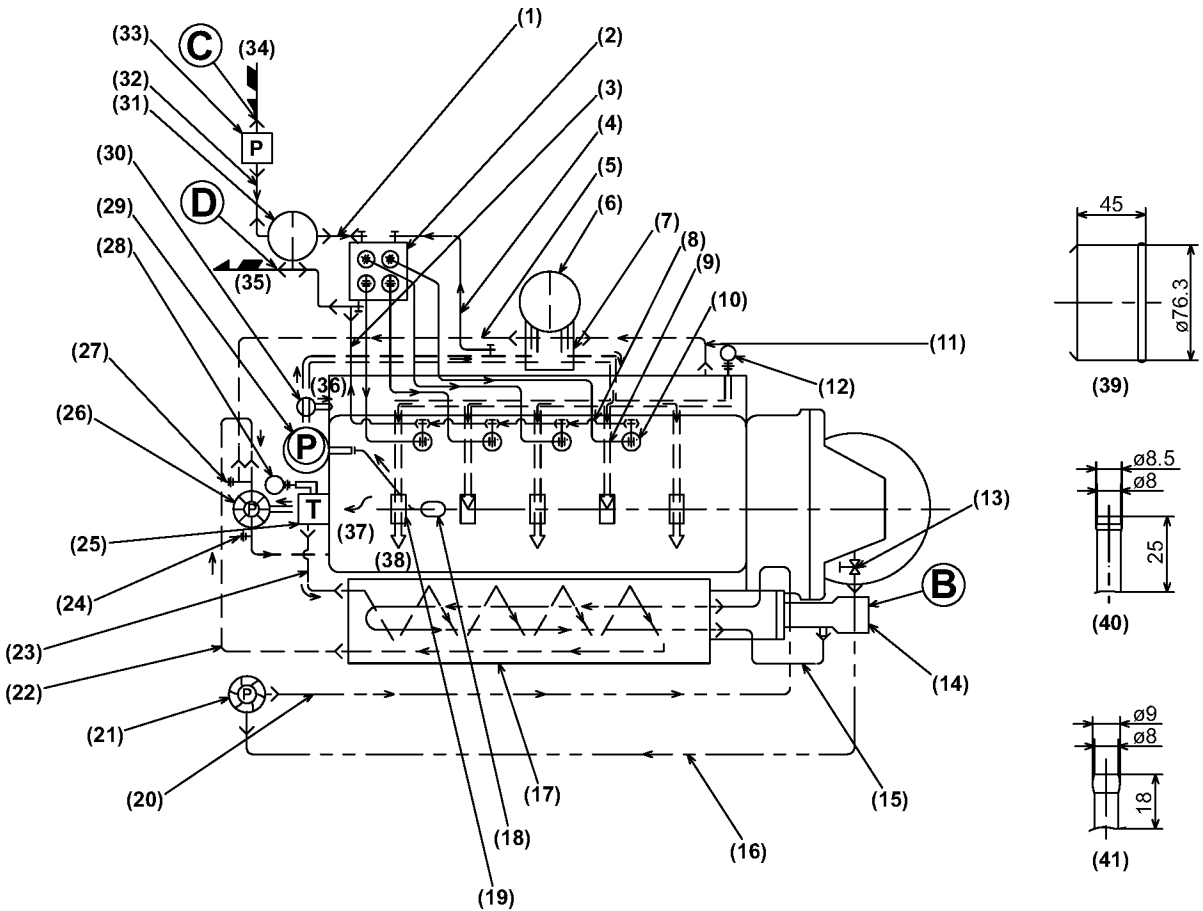

Figure 7

026109-00X

- 1 – * 7 x t4.5 Rubber Hose
- 2 – Fuel Injection Pump
- 3 – * 5 x t4.5 Rubber Hose
- 4 – 4.76x t0.7 Steel Pipe
- 5 – 9 x t3.5 Rubber Hose
- 6 – Lubricating Oil Filter (cartridge type)
- 7 – Lubricating Oil Cooler
- 8 – * 5 x t4.5 Rubber Hose
- 9 – Fuel High-Pressure Pipe 6.35 x t2.375 Steel Pipe
- 10 – Fuel Injection Nozzle
- 11 – 9 x t3.5 Rubber Hose
- 12 – Oil Pressure Switch
- 13 – Seacock
- 14 – Mixing Elbow
- 15 – 25.4 x t4.3 Rubber Hose
- 16 – 25.4 x t4.3 Rubber Hose
- 17 – Heat Exchanger
- 18 – Lubricating Oil Inlet Filter
- 19 – Main Bearing
- 20 – 25.4 x t4.3 Rubber Hose
- 21 – Cooling Water Pump
- 22 – 28 x t4 Rubber Hose
- 23 – 28 x t4 Rubber Hose
- 24 – Hot Water Connection Outlet (R3/8)
- 25 – Thermostat
- 26 – Coolant Pump (fresh water)
- 27 – Hot Water Connection Inlet (R3/8)
- 28 – Coolant Temperature Switch
- 29 – Lubricating Oil Pump
- 30 – Pressure Control Valve
- 31 – Fuel Filter (cartridge type)
- 32 – * 7 x t4.5 Rubber Hose
- 33 – Fuel Feed Pump
- 34 – Fuel Inlet
- 35 – Fuel Overflow
- 36 – To Oil Pan
- 37 – From Cylinder Head
- 38 – To Camshaft
- 39 – Detail of Part B
- 40 – Detail of Part C
- 41 – Detail of Part D

4JH4-TE with ZF30M

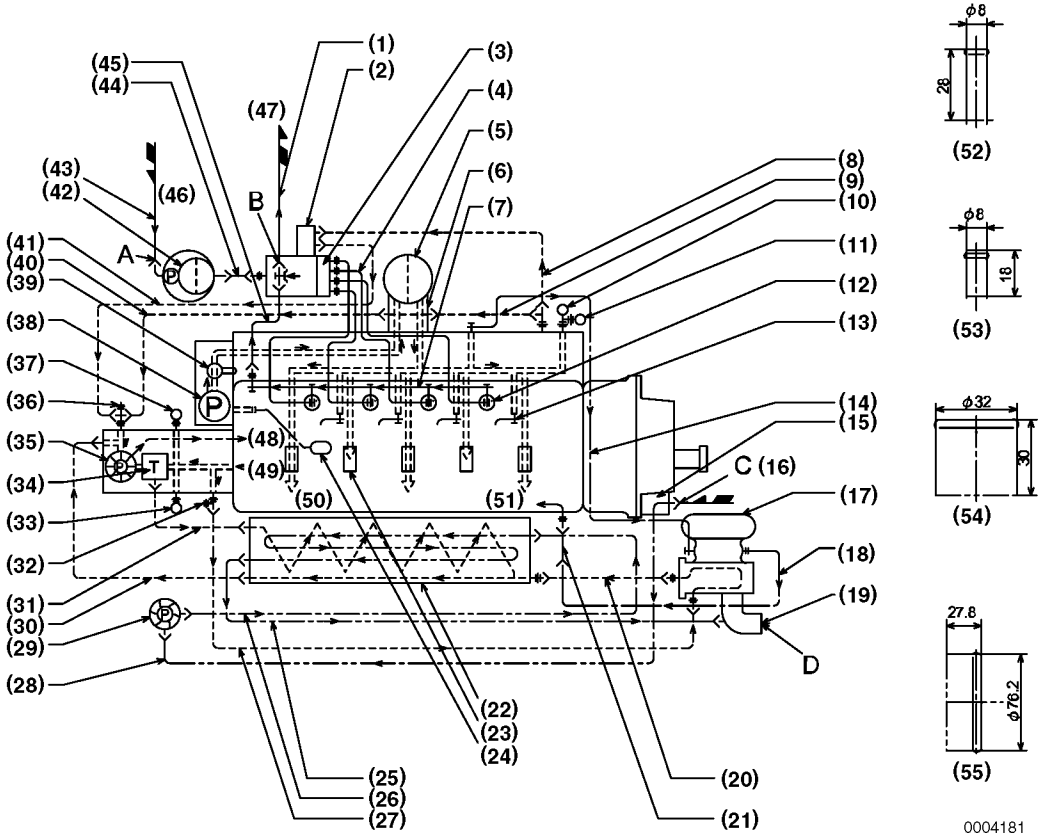

Figure 8

0004181

- | | |
|---|---------------------------|
| 1 – * 7 x t4.5 Rubber Hose | 45 – 5 x t4.5 Rubber Hose |
| 2 – W-C S.D. | 46 – Diesel Fuel Inlet |
| 3 – Fuel Injection Pump | 47 – Fuel Overflow |
| 4 – Fuel High-Pressure Pipe 6.35 x t2.175 STS | 48 – To Block |
| 5 – Lubrication Oil Filter (cartridge type) | 49 – From Head |
| 6 – Lubrication Oil Cooler | 50 – To Camshaft |
| 7 – 4.76 x t0.7 Double-Walled Steel Tube | 51 – To Oil Pan |
| 8 – 10 x t4.3 Rubber Hose | 52 – Detail of Part A |
| 9 – 13 x t3.5 Rubber Hose | 53 – Detail of Part B |
| 10 – Oil Pressure Switch | 54 – Detail of Part C |
| 11 – Oil Pressure Sensor (option) | 55 – Detail of Part D |
| 12 – Fuel Injection Nozzle | |
| 13 – Piston Cooling Oil Jet | |
| 14 – 8 x t0.8 STKM | |
| 15 – Clutch Lubrication Oil Cooler | |
| 16 – Seawater Inlet | |
| 17 – Turbocharger | |
| 18 – 17 x t1.2 STKM | |
| 19 – Mixing Elbow | |
| 20 – 8.5 x t3.5 Rubber Hose | |
| 21 – 17 x t3 Rubber Hose | |
| 22 – Heat Exchanger | |
| 23 – Main Bearing | |
| 24 – Lubrication Oil Inlet Filter | |
| 25 – 25.4 x t4.3 Rubber Hose | |
| 26 – 25.4 x t4.3 Rubber Hose | |
| 27 – 7.5 x t2.5 Rubber Hose | |
| 28 – 25.4 x t4.3 Rubber Hose | |
| 29 – Cooling Water Pump (seawater) | |
| 30 – 28 x t4 Rubber Hose | |
| 31 – 28 x t4 Rubber Hose | |
| 32 – Hot Water Connection Outlet | |
| 33 – Coolant Temperature Switch | |
| 34 – Thermostat | |
| 35 – Cooling Water Pump (coolant) | |
| 36 – Hot Water Connection Return | |
| 37 – Coolant Temperature Sensor (option) | |
| 38 – Lubrication Oil Pump | |
| 39 – Pressure Control Valve | |
| 40 – 13 x t3.5 Rubber Hose | |
| 41 – 10 x t3 Rubber Hose | |
| 42 – Diesel Fuel Filter (cartridge type) | |
| 43 – 7 x t4.5 Rubber Hose | |
| 44 – 7 x t4.5 Rubber Hose | |

4JH4-TE with KM4A2

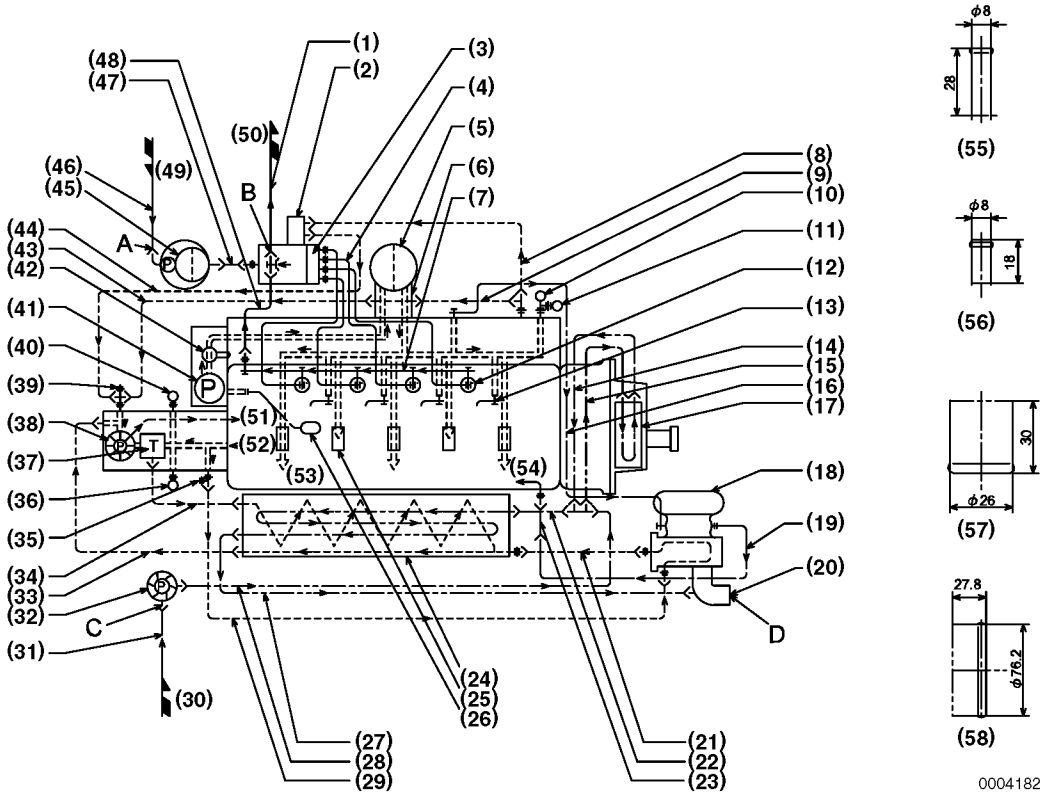

Figure 9

0004182

- 1 – * 7 x t4.5 Rubber Hose
- 2 – W-C S.D.
- 3 – Fuel Injection Pump
- 4 – Fuel High-Pressure Pipe 6.35 x t2.175 STS
- 5 – Lubrication Oil Filter (cartridge type)
- 6 – Lubrication Oil Cooler
- 7 – 4.76 x t0.7 Double-Walled Steel Tube
- 8 – 10 x t3 Rubber Hose
- 9 – 13 x t4.5 Rubber Hose
- 10 – Oil Pressure Switch
- 11 – Oil Pressure Sensor (option)
- 12 – Fuel Injection Nozzle
- 13 – Piston Cooling Oil Jet
- 14 – 13 x t4 Rubber Hose
- 15 – 13 x t4 Rubber Hose
- 16 – 8 x t0.8 STKM
- 17 – Clutch Lubrication Oil Cooler
- 18 – Turbocharger
- 19 – 17 x t1.2 STKM
- 20 – Mixing Elbow
- 21 – 8.5 x t3.5 Rubber Hose
- 22 – 25.4 x t4.3 Rubber Hose
- 23 – 17 x t3 Rubber Hose
- 24 – Heat Exchanger
- 25 – Main Bearing
- 26 – Lubrication Oil Inlet Filter
- 27 – 25.4 x t4.3 Rubber Hose
- 28 – 25.4 x t4.3 Rubber Hose
- 29 – 7.5 x t2.5 Rubber Hose
- 30 – Seawater Inlet
- 31 – 25.4 x t4.3 Rubber Hose
- 32 – Cooling Water Pump (seawater)
- 33 – 28 x t4 Rubber Hose
- 34 – 28 x t4 Rubber Hose
- 35 – Hot Water Connection Outlet
- 36 – Coolant Temperature Switch
- 37 – Thermostat
- 38 – Cooling Water Pump (coolant)
- 39 – Hot Water Connection Return
- 40 – Coolant Temperature Sensor (option)
- 41 – Lubrication Oil Pump
- 42 – Pressure Control Valve
- 43 – 13 x t3.5 Rubber Hose
- 44 – 10 x t3 Rubber Hose
- 45 – Diesel Fuel Filter (cartridge type)
- 46 – * 7 x t4.5 Rubber Hose
- 47 – * 7 x t4.5 Rubber Hose
- 48 – * 5 x t4.5 Rubber Hose
- 49 – Diesel Fuel Inlet
- 50 – Fuel Overflow
- 51 – To Block
- 52 – From Head
- 53 – To Camshaft
- 54 – To Oil Pan
- 55 – Detail of Part A
- 56 – Detail of Part B
- 57 – Detail of Part C
- 58 – Detail of Part D

4JH4-TE with KM4A / ZF25A

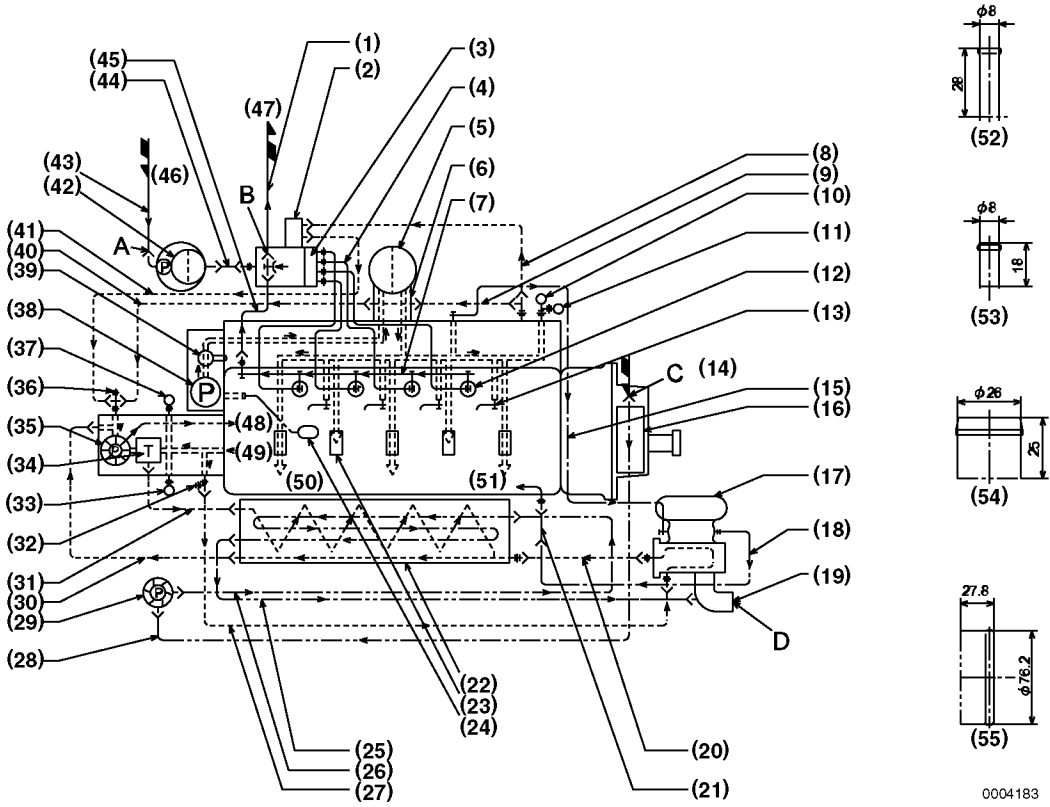

Figure 10

0004183

- | | |
|---|-----------------------------|
| 1 – * 7 x t4.5 Rubber Hose | 45 – * 5 x t4.5 Rubber Hose |
| 2 – W-C S.D. | 46 – Diesel Fuel Inlet |
| 3 – Fuel Injection Pump | 47 – Fuel Overflow |
| 4 – Fuel High-Pressure Pipe 6.35 x t2.175 STS | 48 – To Block |
| 5 – Lubrication Oil Filter (cartridge type) | 49 – From Head |
| 6 – Lubrication Oil Cooler | 50 – To Camshaft |
| 7 – 4.76 x t0.7 Double-Walled Steel Tube | 51 – To Oil Pan |
| 8 – 10 x t3 Rubber Hose | 52 – Detail of Part A |
| 9 – 13 x t3.5 Rubber Hose | 53 – Detail of Part B |
| 10 – Oil Pressure Switch | 54 – Detail of Part C |
| 11 – Oil Pressure Sensor | 55 – Detail of Part D |
| 12 – Fuel Injection Nozzle | |
| 13 – Piston Cooling Oil Jet | |
| 14 – Seawater Inlet | |
| 15 – 8 x t0.8 STKM | |
| 16 – Clutch Lubrication Oil Cooler | |
| 17 – Turbocharger | |
| 18 – 17 x t1.2 STKM | |
| 19 – Mixing Elbow | |
| 20 – 8.5 x t3.5 Rubber Hose | |
| 21 – 17 x t3 Rubber Hose | |
| 22 – Heat Exchanger | |
| 23 – Main Bearing | |
| 24 – Lubrication Oil Inlet Filter | |
| 25 – 25.4 x t4.3 Rubber Hose | |
| 26 – 25.4 x t4.3 Rubber Hose | |
| 27 – 7.5 x t2.5 Rubber Hose | |
| 28 – 25.4 x t4.3 Rubber Hose | |
| 29 – Cooling Water Pump (seawater) | |
| 30 – 28 x t4 Rubber Hose | |
| 31 – 28 x t4 Rubber Hose | |
| 32 – Hot Water Connection Outlet | |
| 33 – Coolant Temperature Switch | |
| 34 – Thermostat | |
| 35 – Cooling Water Pump (coolant) | |
| 36 – Hot Water Connection Return | |
| 37 – Coolant Temperature Sensor (option) | |
| 38 – Lubrication Oil Pump | |
| 39 – Pressure Control Valve | |
| 40 – 13 x t3.5 Rubber Hose | |
| 41 – 10 x t3 Rubber Hose | |
| 42 – Diesel Fuel Filter (cartridge type) | |
| 43 – * 7 x t4.5 Rubber Hose | |
| 44 – * 7 x t4.5 Rubber Hose | |

4JH4-TE with SD50 (SD40)

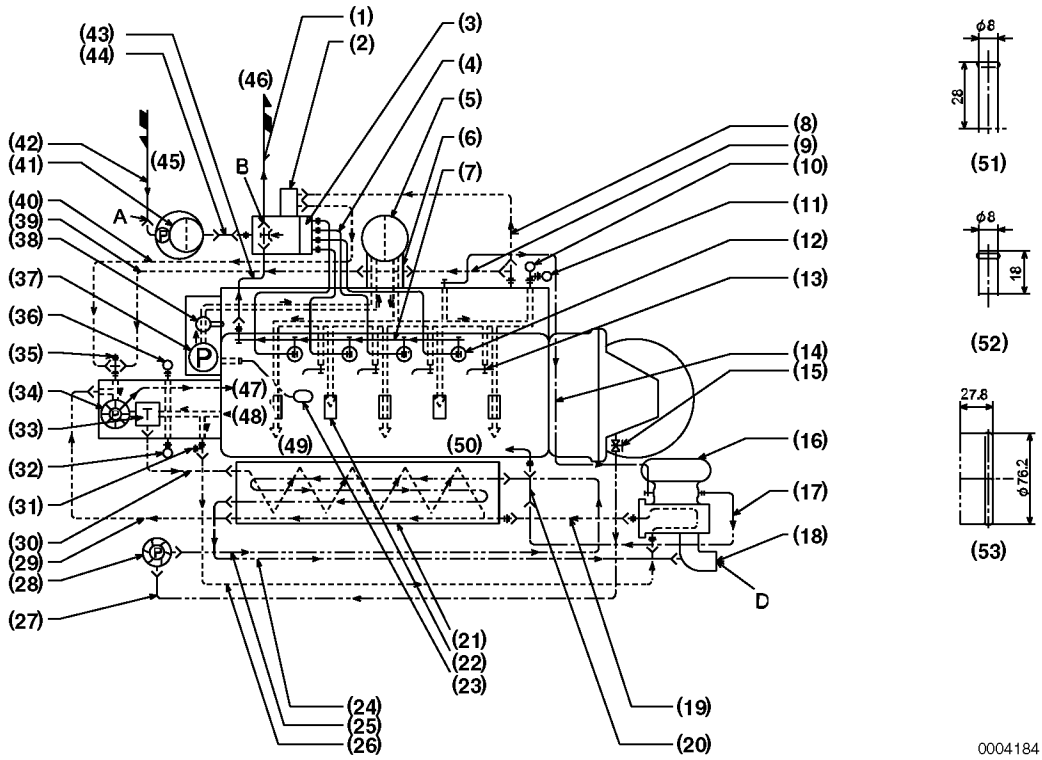

Figure 11

0004184

- 1 – * 7 x t4.5 Rubber Hose
- 2 – W-C S.D.
- 3 – Fuel Injection Pump
- 4 – Fuel High-Pressure Pipe 6.35 x t2.175 STS
- 5 – Lubrication Oil Filter (cartridge type)
- 6 – Lubrication Oil Cooler
- 7 – 4.76 x t0.7 Double-Walled Steel Tube
- 8 – 10 x t3 Rubber Hose
- 9 – 13 x t3.5 Rubber Hose
- 10 – Oil Pressure Switch
- 11 – Oil Pressure Sensor (option)
- 12 – Fuel Injection Nozzle
- 13 – Piston Cooling Oil Jet
- 14 – 8 x t0.8 STKM
- 15 – Seacock
- 16 – Turbocharger
- 17 – 17 x t1.2 STKM
- 18 – Mixing Elbow
- 19 – 8.5 x t3.5 Rubber Hose
- 20 – 17 x t3 Rubber Hose
- 21 – Heat Exchanger
- 22 – Main Bearing
- 23 – Lubrication Oil Inlet Filter
- 24 – 25.4 x t4.3 Rubber Hose
- 25 – 25.4 x t4.3 Rubber Hose
- 26 – 7.5 x t2.5 Rubber Hose
- 27 – 25.4 x t4.3 Rubber Hose
- 28 – Cooling Water Pump (seawater)
- 29 – 28 x t4 Rubber Hose
- 30 – 28 x t4 Rubber Hose
- 31 – Hot Water Connection Outlet
- 32 – Coolant Temperature Switch
- 33 – Thermostat
- 34 – Cooling Water Pump (coolant)
- 35 – Hot Water Connection Return
- 36 – Coolant Temperature Sensor (option)
- 37 – Lubrication Oil Pump
- 38 – Pressure Control Valve
- 39 – 13 x t3.5 Rubber Hose
- 40 – 10 x t3 Rubber Hose
- 41 – Diesel Fuel Filter (cartridge type)
- 42 – * 7 x t4.5 Rubber Hose
- 43 – * 7 x t4.5 Rubber Hose
- 44 – * 5 x t4.5 Rubber Hose
- 45 – Diesel Fuel Inlet
- 46 – Fuel Overflow
- 47 – To Block
- 48 – From Head
- 49 – To Camshaft
- 50 – To Oil Pan
- 51 – Detail of Part A
- 52 – Detail of Part B
- 53 – Detail of Part D

4JH4-HTE1 / 4JH4-HTE with KM4A2

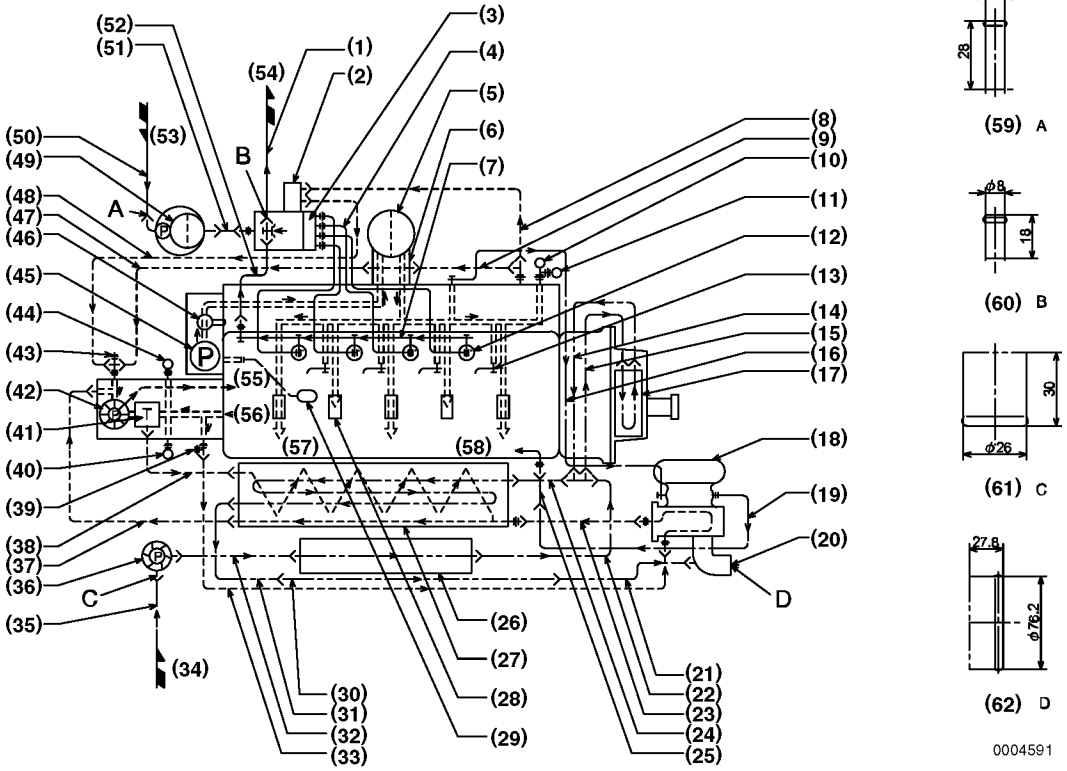
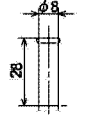
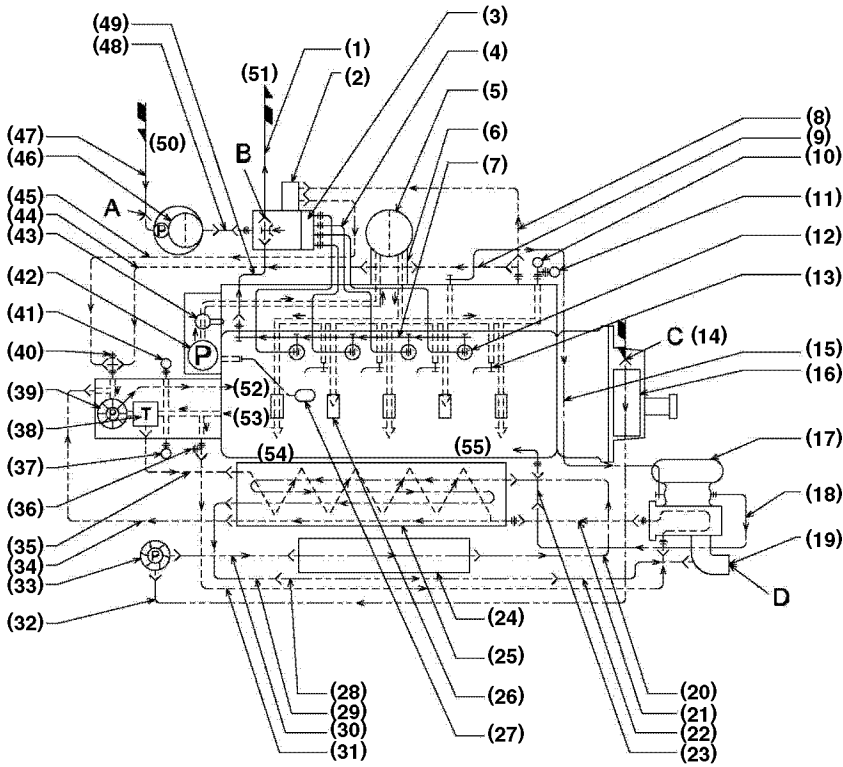

Figure 12

- 1 – * 7 x t4.5 Rubber Hose
- 2 – W-C S.D.
- 3 – Fuel Injection Pump
- 4 – Fuel High-Pressure Pipe 6.35 x t2.175 STS
- 5 – Lubrication Oil Filter (cartridge type)
- 6 – Lubrication Oil Cooler
- 7 – 4.76 x t0.7 Double-Walled Steel Tube
- 8 – 10 x t3 Rubber Hose
- 9 – 13 x t3.5 Rubber Hose
- 10 – Oil Pressure Switch
- 11 – Oil Pressure Sensor (option)
- 12 – Fuel Injection Nozzle
- 13 – Piston Cooling Oil Jet
- 14 – 13 x t4 Rubber Hose
- 15 – 13 x t4 Rubber Hose
- 16 – 8 x t0.8 STKM
- 17 – Clutch Lubrication Oil Cooler
- 18 – Turbocharger
- 19 – 17 x t1.2 STKM
- 20 – Mixing Elbow
- 21 – 25.4 x t4.3 Rubber Hose
- 22 – 25.4 x t4.3 Rubber Hose
- 23 – 8.5 x t3.5 Rubber Hose
- 24 – 25.4 x t4.3 Rubber Hose
- 25 – 17 x t3 Rubber Hose
- 26 – Intercooler
- 27 – Heat Exchanger
- 28 – Main Bearing
- 29 – Lubrication Oil Inlet Filter
- 30 – 25 x t2 C1201T
- 31 – 25.4 x t4.3 Rubber Hose
- 32 – 25.4 x t4.3 Rubber Hose
- 33 – 7.5 x t2.5 Rubber Hose
- 34 – Seawater Inlet
- 35 – 25.4 x t4.3 Rubber Hose
- 36 – Cooling Water Pump (seawater)
- 37 – 28 x t4 Rubber Hose
- 38 – 28 x t4 Rubber Hose
- 39 – Hot Water Connection Outlet
- 40 – Coolant Temperature Switch
- 41 – Thermostat
- 42 – Cooling Water Pump (coolant)
- 43 – Hot Water Connection Return
- 44 – Coolant Temperature Sensor (option)
- 45 – Lubrication Oil Pump
- 46 – Pressure Control Valve
- 47 – 13 x t3.5 Rubber Hose
- 48 – 10 x t3 Rubber Hose
- 49 – Diesel Fuel Filter (cartridge type)
- 50 – * 7 x t4.5 Rubber Hose
- 51 – * 7 x t4.5 Rubber Hose
- 52 – * 5 x t4.5 Rubber Hose
- 53 – Diesel Fuel Inlet
- 54 – Diesel Fuel Overflow
- 55 – To Block
- 56 – From Head
- 57 – To Camshaft
- 58 – To Oil Pan
- 59 – Detail of Part A
- 60 – Detail of Part B
- 61 – Detail of Part C
- 62 – Detail of Part B

4JH4-HTE1 / 4JH4-HTE with KMH4A / ZF25A



(56) A



(57) B

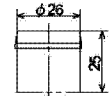

(58) C

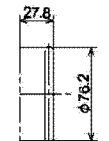

(59) D

0004592

Figure 13

- 1 – * 7 x t4.5 Rubber Hose
- 2 – W-C S.D.
- 3 – Fuel Injection Pump
- 4 – Fuel High-Pressure Pipe 6.35 x t2.175 STS
- 5 – Lubrication Oil Filter (cartridge type)
- 6 – Lubrication Oil Cooler
- 7 – 4.76 x t0.7 Double-Walled Steel Tube
- 8 – 10 x t3 Rubber Hose
- 9 – 13 x t3.5 Rubber Hose
- 10 – Oil Pressure Switch
- 11 – Oil Pressure Sensor (option)
- 12 – Fuel Injection Nozzle
- 13 – Piston Cooling Oil Jet
- 14 – Seawater Inlet
- 15 – 8 x t0.8 STKM
- 16 – Clutch Lubrication Oil Cooler
- 17 – Turbocharger
- 18 – 17 x t1.2 STKM
- 19 – Mixing Elbow
- 20 – 25.4 x t4.3 Rubber Hose
- 21 – 8.5 x t3.5 Rubber Hose
- 22 – 25.4 x t4.3 Rubber Hose
- 23 – 17 x t3 Rubber Hose
- 24 – Intercooler
- 25 – Heat Exchanger
- 26 – Main Bearing
- 27 – Lubrication Oil Inlet Filter
- 28 – 25 x t2 C1201T
- 29 – 25.4 x t4.3 Rubber Hose
- 30 – 25.4 x t4.3 Rubber Hose
- 31 – 7.5 x t2.5 Rubber Hose
- 32 – 25.4 x t4.3 Rubber Hose
- 33 – Cooling Water Pump (seawater)
- 34 – 28 x t4 Rubber Hose
- 35 – 28 x t4 Rubber Hose
- 36 – Hot Water Connection Outlet
- 37 – Coolant Temperature Switch
- 38 – Thermostat
- 39 – Cooling Water Pump (coolant)
- 40 – Hot Water Connection Return
- 41 – Coolant Temperature Sensor (option)
- 42 – Lubrication Oil Pump
- 43 – Pressure Control Valve
- 44 – 13 x t3.5 Rubber Hose
- 45 – 10 x t3 Rubber Hose
- 46 – Diesel Fuel Filter
- 47 – * 7 x t4.5 Rubber Hose
- 48 – * 7 x t4.5 Rubber Hose
- 49 – * 5 x t4.5 Rubber Hose
- 50 – Diesel Fuel Inlet
- 51 – Fuel Overflow
- 52 – To Block
- 53 – From Head
- 54 – To Camshaft
- 55 – To Oil Pan
- 56 – Detail of Part A
- 57 – Detail of Part B
- 58 – Detail of Part C
- 59 – Detail of Part D

4JH4-HTE1 / 4JH4-HTE with ZF30

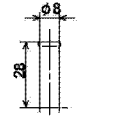
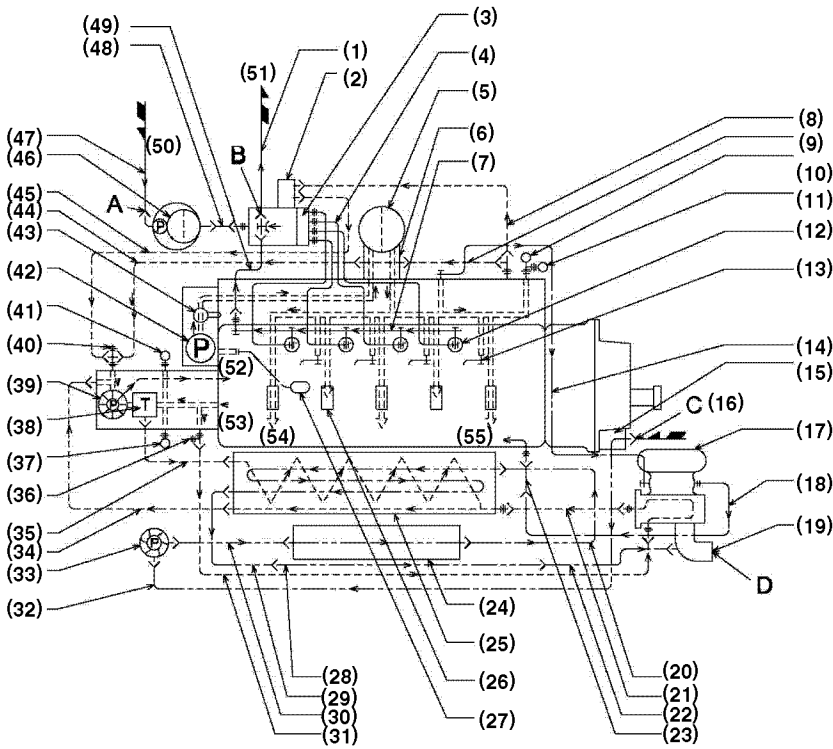

(56) A

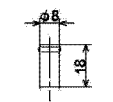

(57) B

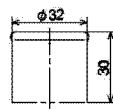

(58) C

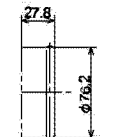

(59) D

0004593

Figure 14

- 1 – * 7 x t4.5 Rubber Hose
- 2 – W-C S.D.
- 3 – Fuel Injection Pump
- 4 – Fuel High-Pressure Pipe 6.35 x t2.175 STS
- 5 – Lubrication Oil Filter (cartridge type)
- 6 – Lubrication Oil Cooler
- 7 – 4.76 x t0.7 Double-Walled Steel Tube
- 8 – 10 x t3 Rubber Hose
- 9 – 13 x t3.5 Rubber Hose
- 10 – Oil Pressure Switch
- 11 – Oil Pressure Sensor (option)
- 12 – Fuel Injection Nozzle
- 13 – Piston Cooling Oil Jet
- 14 – Seawater Inlet
- 15 – 8 x t0.8 STKM
- 16 – Clutch Lubrication Oil Cooler
- 17 – Turbocharger
- 18 – 17 x t1.2 STKM
- 19 – Mixing Elbow
- 20 – 25.4 x t4.3 Rubber Hose
- 21 – 8.5 x t3.5 Rubber Hose
- 22 – 25.4 x t4.3 Rubber Hose
- 23 – 17 x t3 Rubber Hose
- 24 – Intercooler
- 25 – Heat Exchanger
- 26 – Main Bearing
- 27 – Lubrication Oil Inlet Filter
- 28 – 25 x t2 C1201T
- 29 – 25.4 x t4.3 Rubber Hose
- 30 – 25.4 x t4.3 Rubber Hose
- 31 – 7.5 x t2.5 Rubber Hose
- 32 – 25.4 x t4.3 Rubber Hose
- 33 – Cooling Water Pump (seawater)
- 34 – 28 x t4 Rubber Hose
- 35 – 28 x t4 Rubber Hose
- 36 – Hot Water Connection Outlet
- 37 – Coolant Temperature Switch
- 38 – Thermostat
- 39 – Cooling Water Pump (coolant)
- 40 – Hot Water Connection Return
- 41 – Coolant Temperature Sensor (option)
- 42 – Lubrication Oil Pump
- 43 – Pressure Control Valve
- 44 – 13 x t3.5 Rubber Hose
- 45 – 10 x t3 Rubber Hose
- 46 – Diesel Fuel Filter
- 47 – * 7 x t4.5 Rubber Hose
- 48 – * 7 x t4.5 Rubber Hose
- 49 – * 5 x t4.5 Rubber Hose
- 50 – Diesel Fuel Inlet
- 51 – Fuel Overflow
- 52 – To Block
- 53 – From Head
- 54 – To Camshaft
- 55 – To Oil Pan
- 56 – Detail of Part A
- 57 – Detail of Part B
- 58 – Detail of Part C
- 59 – Detail of Part D

This Page Intentionally Left Blank

WIRING DIAGRAMS

Allowable length by cross sectional area of battery cable	
Section of cable mm ² (in. ²)	Allowable length L = 1 + 2 + 3 m (ft.)
15 (0.023)	< 0.86 (0.26)
20 (0.031)	< 1.3 (0.40)
30 (0.046)	< 2.3 (0.70)
40 (0.062)	< 2.8 (0.85)
50 (0.077)	< 3.5 (1.07)
60 (0.093)	< 4.1 (1.25)

3JH5E / 4JH5E with C-Type Instrument Panel (Optional)

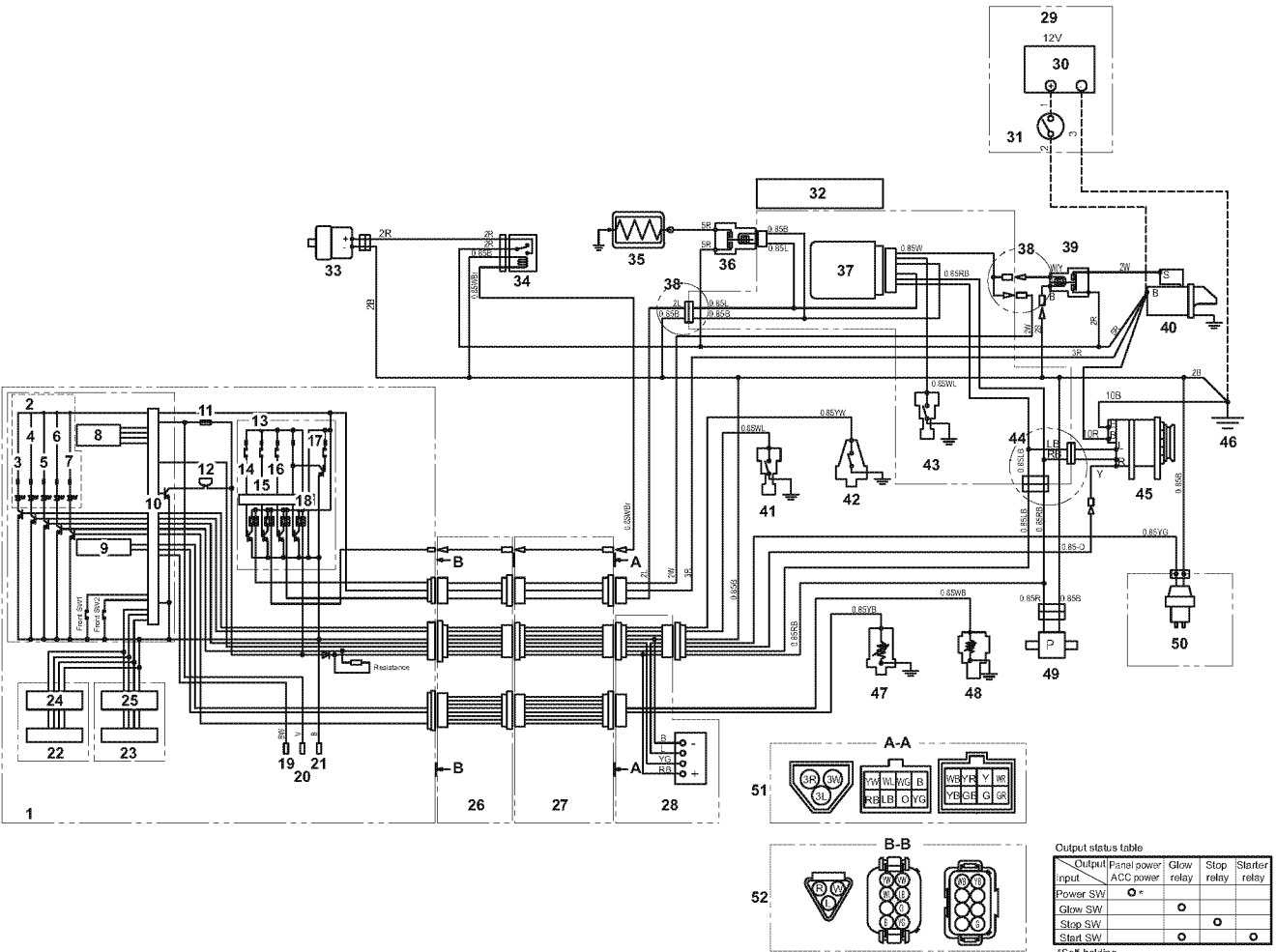

Figure 15

Output status table

Output input	Panel ACC power	Glow relay	Stop relay	Starter relay
Power SW	○*			
Glow SW		○		
Stop SW			○	
Start SW				○

*Self-holding

043783-00X00

3JH5E / 4JH5E with C-Type Instrument Panel (Optional)

Color Coding		Engine Harness
R	Red	+
B	Black	-
W	White	Ignition
L	Blue	Air Heater / Glow (option)
RB	Red / Black	Alternator Exciter
LB	Blue / Black	Alternator Charge Alarm
YW	Yellow / White	Engine Oil Pressure Alarm
YB	Yellow / Black	Engine Oil Pressure
YG	Yellow / Green	Sail Drive Seal
WL	White / Blue	Water Temperature Alarm
WB	White / Black	Water Temperature
V	Purple	ACC Power
BW	Blue / White	Fuel Tank Level
O	Orange	Pulse for Tachometer
WBr	White / Brown	Electric Stop

- 1 – Instrument panel C30 (Main station) (Option)
- 2 – Alarm lamps (3 to 7)
- 3 – Engine oil low pressure indicator
- 4 – Coolant high temperature Indicator
- 5 – Water in sail drive seal indicator
- 6 – Battery low charge indicator
- 7 – Water in fuel filter indicator
- 8 – Tachometer
- 9 – Segmented display
- 10 – Control unit (Tacho gauge)
- 11 – Fuse 3A
- 12 – Buzzer
- 13 – Switch module (14 to 18)
- 14 – Start switch
- 15 – Stop switch
- 16 – Glow switch
- 17 – Power switch
- 18 – Control unit (Switch module)
- 19 – Fuel tank level sensor input
- 20 – ACC power

- 21 – ACC GND
- 22 – Coolant temperature gauge
- 23 – Engine oil pressure gauge
- 24 – Control unit (Coolant temperature gauge)
- 25 – Control unit (Engine oil pressure gauge)
- 26 – Conversion harness
- 27 – Wire harness
- 28 – Water in sail drive seal sensor amplifier (Sail drive only)
- 29 – Procured by customer
- 30 – Battery
- 31 – Battery switch
- 32 – (Option) Controller (Air heater) assembly
- 33 – Engine stop solenoid
- 34 – Stop relay
- 35 – Air heater
- 36 – Air heater relay
- 37 – Air heater controller
- 38 – Remove the connector of engine harness from starter relay and air heater relay. Reconnect with the connector of air heater harness.
- 39 – Starter relay
- 40 – Starter
- 41 – Coolant temperature switch
- 42 – Engine oil pressure switch
- 43 – Coolant temperature switch (to air heater controller)
- 44 – Remove the connector from alternator. Reconnect with the connector of air heater harness.
- 45 – Alternator
- 46 – Ground
- 47 – Oil pressure sender
- 48 – Coolant temperature sender
- 49 – Fuel feed pump
- 50 – Water in sail drive seal sensor (Sail drive only)
- 51 – Details of coupler (Wire harness, view from A-A)
- 52 – Details of coupler (Conversion harness, view from B-B)

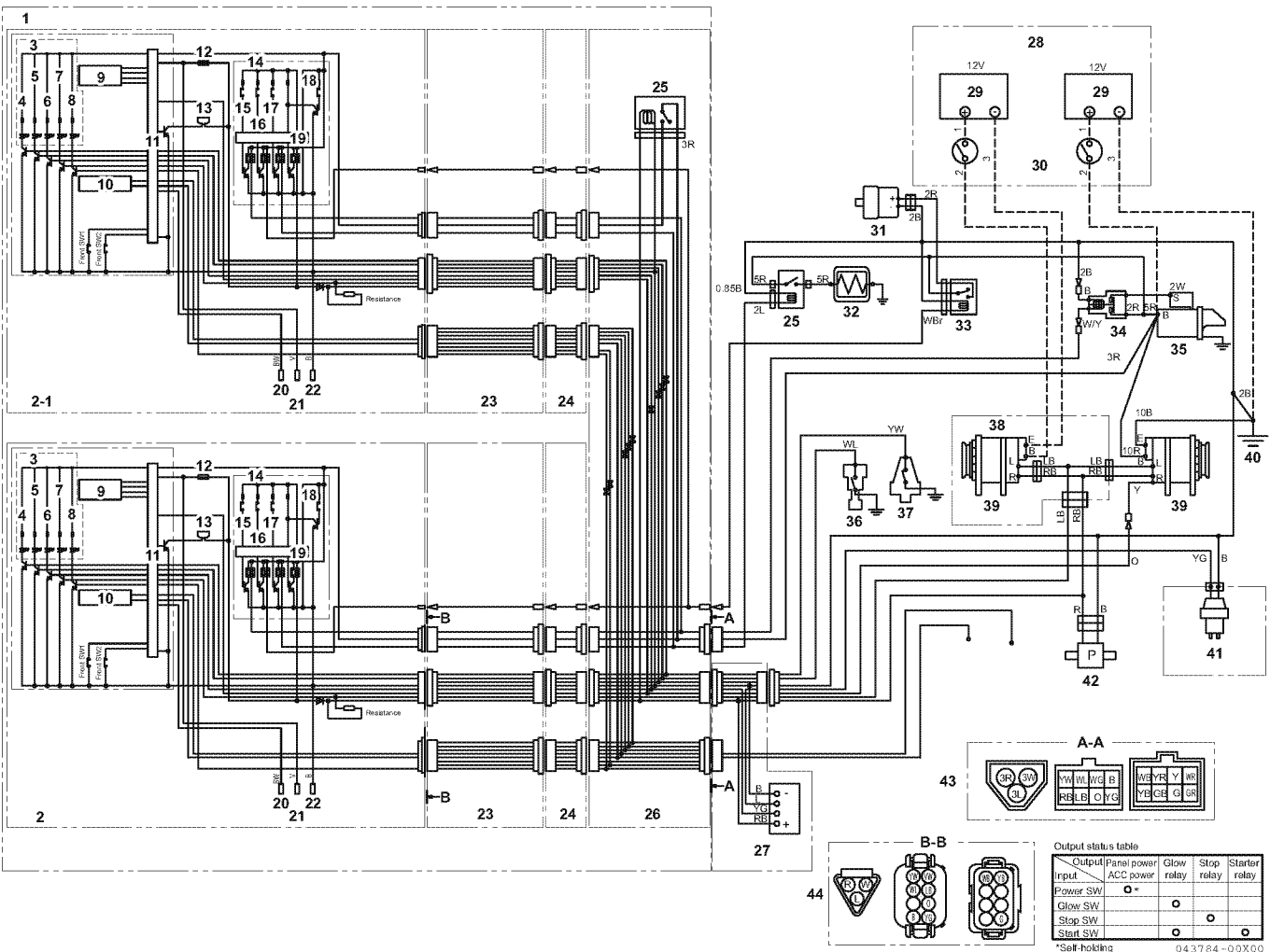

Figure 16

**3JH5E / 4JH5E with 12V B and B x B
Type Instrument Panel (Optional)**

Color Coding		Engine Harness
R	Red	+
B	Black	-
W	White	Ignition
L	Blue	Air Heater / Glow (option)
RB	Red / Black	Alternator Exciter
LB	Blue / Black	Alternator Charge Alarm
YW	Yellow / White	Engine Oil Pressure Alarm
YB	Yellow / Black	Engine Oil Pressure
YG	Yellow / Green	Sail Drive Seal
WL	White / Blue	Water Temperature Alarm
WB	White / Black	Water Temperature
V	Purple	ACC Power
BW	Blue / White	Fuel Tank Level
O	Orange	Pulse for Tachometer
WBr	White / Brown	Electric Stop

- 1 – Option (2 Panels)
- 2 – Instrument panel B20
(Main station)
1-Instrument panel B20
(Sub station)
- 3 – Alarm lamps (4 to 8)
- 4 – Engine oil low pressure indicator
- 5 – Coolant high temperature Indicator
- 6 – Water in sail drive seal indicator
- 7 – Battery low charge indicator
- 8 – Water in fuel filter indicator
- 9 – Tachometer
- 10 – Segmented display
- 11 – Control unit (Tacho gauge)
- 12 – Fuse 3A
- 13 – Buzzer
- 14 – Switch module (15 to 19)
- 15 – Start switch
- 16 – Stop switch
- 17 – Glow switch
- 18 – Power switch

- 19 – Control unit (Switch module)
- 20 – Fuel tank level sensor input
- 21 – ACC power
- 22 – ACC GND
- 23 – Conversion harness
- 24 – Wire harness
- 25 – Relay
- 26 – Wire harness for sub panel
- 27 – Water in sail drive seal sensor amplifier (sail drive only)
- 28 – Procured by customer
- 29 – Battery
- 30 – Battery switch
- 31 – Engine stop solenoid
- 32 – Air heater
- 33 – Air heater relay
- 34 – Air heater controller
- 35 – Starter
- 36 – Coolant temperature switch (to air heater controller)
- 37 – Engine oil pressure switch
- 38 – Option (Alternator)
- 39 – Alternator
- 40 – Ground
- 41 – Water in sail drive seal sensor (Sail drive only)
- 42 – Fuel feed pump
- 43 – Details of coupler (Wire harness, view from A-A)
- 44 – Details of coupler (Conversion harness, view from B-B)

3JH5E / 4JH5E with 12V C x B Type Instrument Panel (Optional)

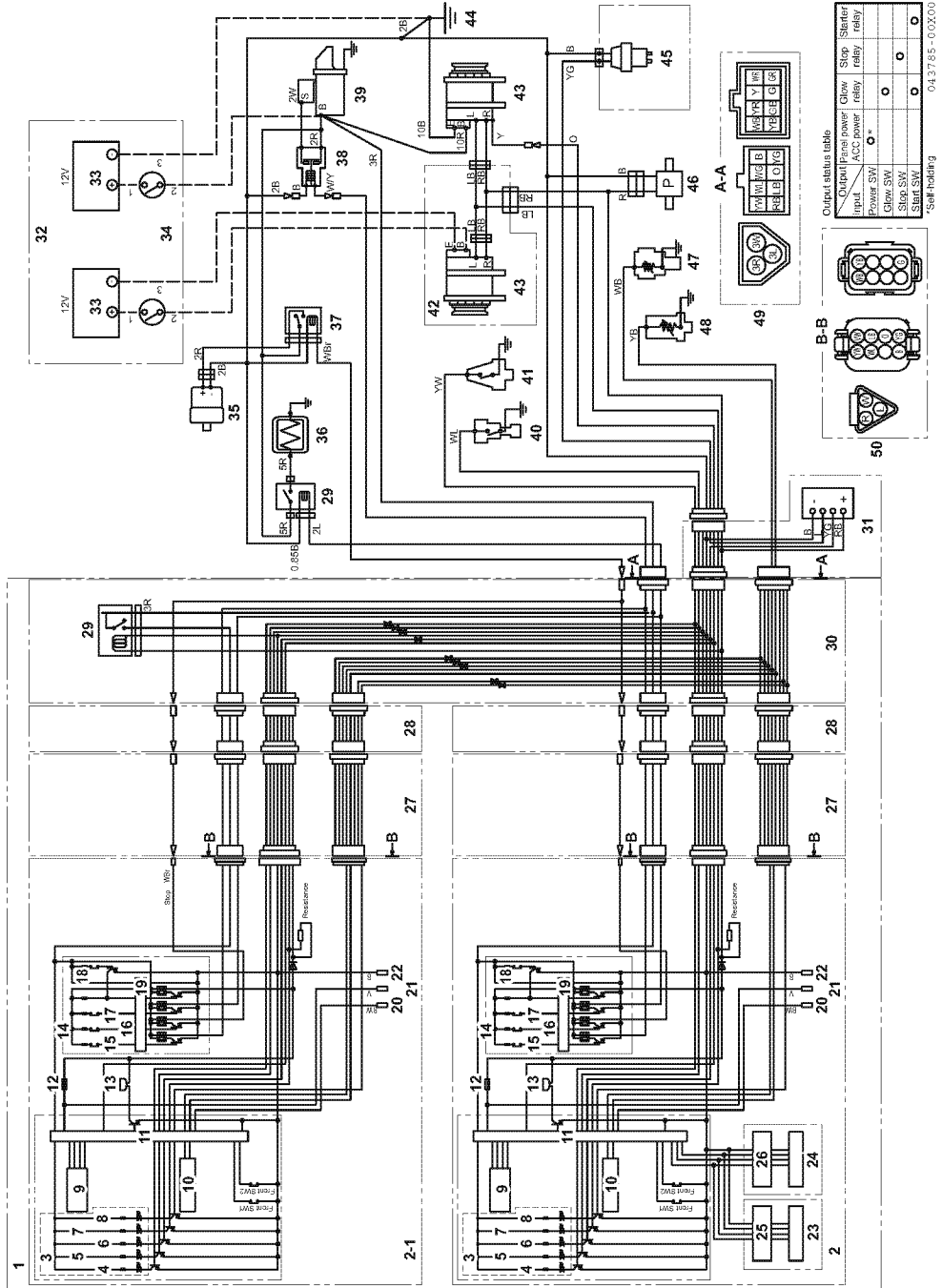

Figure 17

3JH5E / 4JH5E with 12V C x B Type Instrument Panel (Optional)

Color Coding		Engine Harness
R	Red	+
B	Black	-
W	White	Ignition
L	Blue	Air Heater / Glow (option)
RB	Red / Black	Alternator Exciter
LB	Blue / Black	Alternator Charge Alarm
YW	Yellow / White	Engine Oil Pressure Alarm
YB	Yellow / Black	Engine Oil Pressure
YG	Yellow / Green	Sail Drive Seal
WL	White / Blue	Water Temperature Alarm
WB	White / Black	Water Temperature
V	Purple	ACC Power
BW	Blue / White	Fuel Tank Level
O	Orange	Pulse for Tachometer
WBr	White / Brown	Electric Stop

- 1 – Option (2 panels)
- 2 – Instrument panel C30 (Main station)
1- Instrument panel B20 (Sub station)
- 3 – Alarm lamps (4 to 8)
- 4 – Engine oil low pressure indicator
- 5 – Coolant high temperature Indicator
- 6 – Water in sail drive seal indicator
- 7 – Battery low charge indicator
- 8 – Water in fuel filter indicator
- 9 – Tachometer
- 10 – Segmented display
- 11 – Control unit (Tacho gauge)
- 12 – Fuse 3A
- 13 – Buzzer
- 14 – Switch module (15 to 19)
- 15 – Start switch
- 16 – Stop switch
- 17 – Glow switch
- 18 – Power switch
- 19 – Control unit (Switch module)

- 20 – Fuel tank level sensor input
- 21 – ACC Power
- 22 – ACC GND
- 23 – Coolant temperature gauge
- 24 – Oil pressure gauge
- 25 – Control unit (Coolant temperature gauge)
- 26 – Control unit (Oil pressure gauge)
- 27 – Conversion harness
- 28 – Wire harness
- 29 – Relay
- 30 – Wire harness for sub panel
- 31 – Water in sail drive seal sensor amplifier (Sail drive only)
- 32 – Procured by customer
- 33 – Battery
- 34 – Battery switch
- 35 – Engine stop solenoid
- 36 – Air heater
- 37 – Air heater relay
- 38 – Air heater controller
- 39 – Starter
- 40 – Coolant temperature switch (to air heater controller)
- 41 – Engine oil pressure switch
- 42 – Option (Alternator)
- 43 – Alternator
- 44 – Ground
- 45 – Water in sail drive seal sensor (sail drive only)
- 46 – Fuel feed pump
- 47 – Coolant temperature sender
- 48 – Oil pressure sender
- 49 – Details of coupler (Wire harness, view from A-A)
- 50 – Details of coupler (Conversion harness, view from B-B)

4JH4-TE / 4JH4-HTE1 / 4JH4-HTE with B x B Type Panel (Optional)

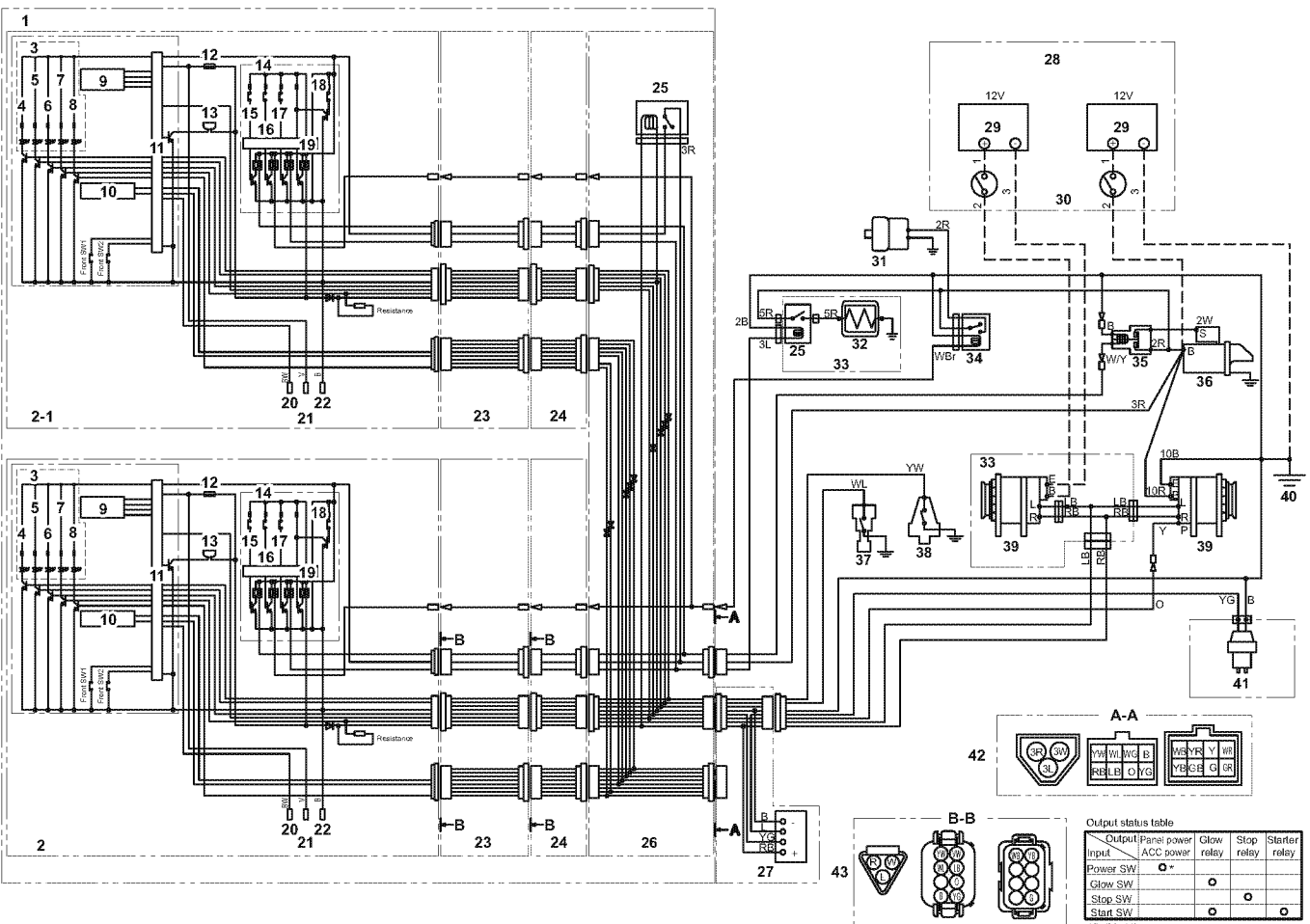

Figure 18

Output status table

Input	Output	Panel power	Glow relay	Stop relay	Starter relay
Power SW	ACC power	o	*		
Glow SW			o		
Stop SW				o	
Start SW					o

*Self-holding

4JH4-TE / 4JH4-HTE1 / 4JH4-HTE with B x B Type Panel (Optional)

Color Coding		Engine Harness
R	Red	+
B	Black	-
W	White	Ignition
L	Blue	Air Heater / Glow (option)
RB	Red / Black	Alternator Exciter
LB	Blue / Black	Alternator Charge Alarm
YW	Yellow / White	Engine Oil Pressure Alarm
YB	Yellow / Black	Engine Oil Pressure
YG	Yellow / Green	Sail Drive Seal
WL	White / Blue	Water Temperature Alarm
WB	White / Black	Water Temperature
V	Purple	ACC Power
BW	Blue / White	Fuel Tank Level
O	Orange	Pulse for Tachometer
WBr	White / Brown	Electric Stop

- 1 – Option (2 panels)
- 2 – Instrument panel B20 (Main station)
 - 1- Instrument panel B20 (Sub station)
- 3 – Alarm lamps (4 to 8)
- 4 – Engine oil low pressure indicator
- 5 – Coolant high temperature Indicator
- 6 – Water in sail drive seal indicator
- 7 – Battery low charge indicator
- 8 – Water in fuel filter indicator
- 9 – Tachometer
- 10 – Segmented display
- 11 – Control unit (Tacho gauge)
- 12 – Fuse 3A
- 13 – Buzzer
- 14 – Switch module (15 to 19)
- 15 – Start switch
- 16 – Stop switch
- 17 – Glow switch
- 18 – Power switch
- 19 – Control unit (Switch module)

- 20 – Fuel tank level sensor input
- 21 – ACC power
- 22 – ACC GND
- 23 – Conversion harness
- 24 – Wire harness
- 25 – Relay
- 26 – Wire Harness for sub panel
- 27 – Water in sail drive seal sensor amplifier (Sail drive only)
- 28 – Procured by customer
- 29 – Battery
- 30 – Battery switch
- 31 – Engine stop solenoid with VE pump
- 32 – Air heater
- 33 – Option (Alternator)
- 34 – Stop relay
- 35 – Starter relay
- 36 – Starter
- 37 – Coolant temperature switch
- 38 – Engine oil pressure switch
- 39 – Alternator
- 40 – Ground
- 41 – Water in sail drive seal sensor (Sail drive only)
- 42 – Details of coupler (Wire harness, view from A-A)
- 43 – Details of coupler (Conversion harness, view from B-B)

4JH4-TE / 4JH4-HTE1 / 4JH4-HTE with C x B Type Panel (Optional)

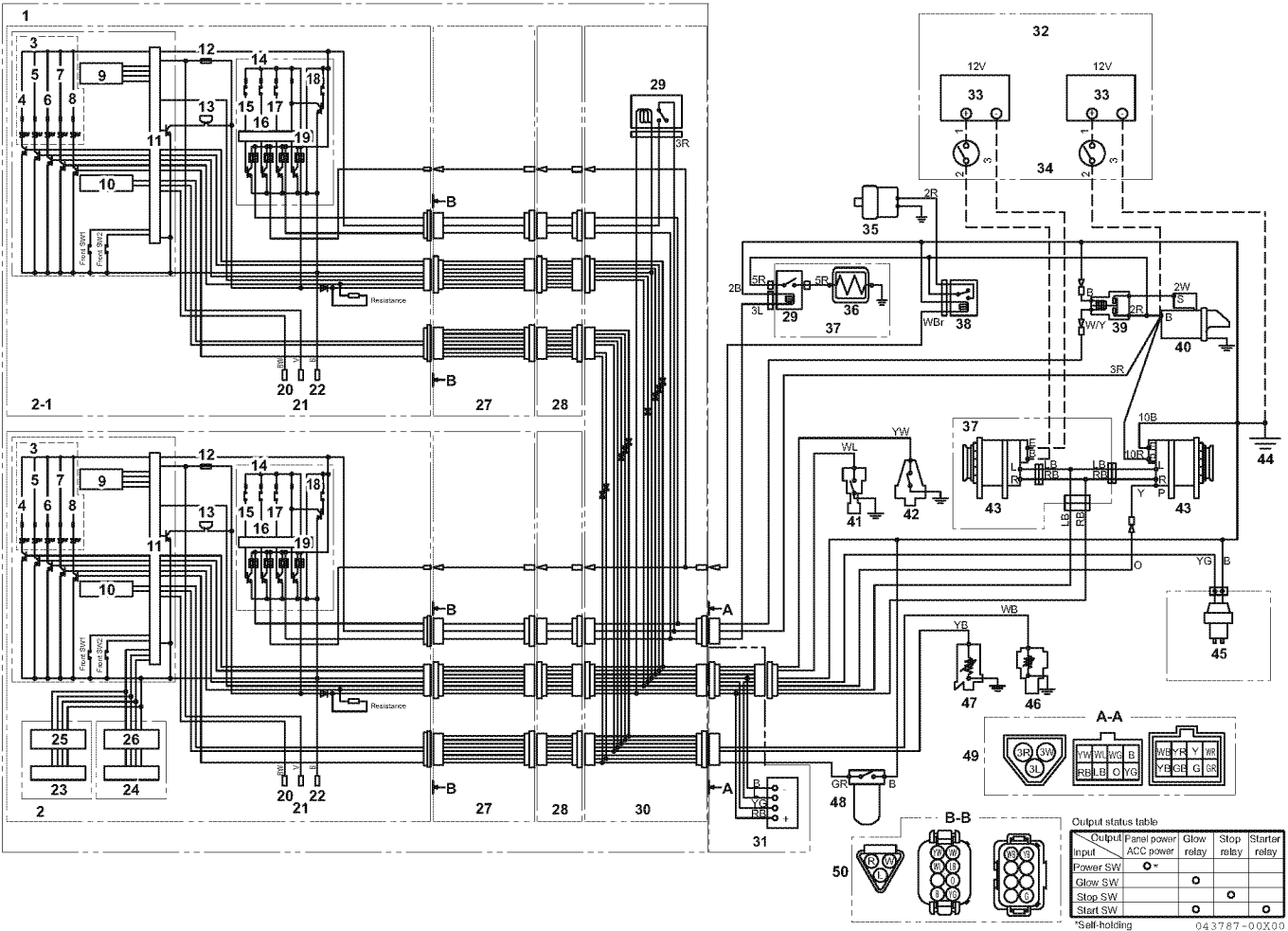

Figure 19

4JH4-TE / 4JH4-HTE1 / 4JH4-HTE with C x B Type Panel (Optional)

Color Coding		Engine Harness
R	Red	+
B	Black	-
W	White	Ignition
L	Blue	Air Heater / Glow (option)
RB	Red / Black	Alternator Exciter
LB	Blue / Black	Alternator Charge Alarm
YW	Yellow / White	Engine Oil Pressure Alarm
YB	Yellow / Black	Engine Oil Pressure
YG	Yellow / Green	Sail Drive Seal
WL	White / Blue	Water Temperature Alarm
WB	White / Black	Water Temperature
V	Purple	ACC Power
BW	Blue / White	Fuel Tank Level
O	Orange	Pulse for Tachometer
WBr	White / Brown	Electric Stop

- 1 – Option (2 panels)
- 2 – Instrument panel C30 (Main station)
 - 1- Instrument panel B20 (Sub station)
- 3 – Alarm lamps (4 to 8)
- 4 – Engine oil low pressure indicator
- 5 – Coolant high temperature Indicator
- 6 – Water in sail drive seal indicator
- 7 – Battery low charge indicator
- 8 – Water in fuel filter indicator
- 9 – Tachometer
- 10 – Segmented display
- 11 – Control unit (Tacho gauge)
- 12 – Fuse 3A
- 13 – Buzzer
- 14 – Switch module (15 to 19)
- 15 – Start switch
- 16 – Stop switch
- 17 – Glow switch
- 18 – Power switch
- 19 – Control unit (Switch module)

- 20 – Fuel tank level sensor input
- 21 – ACC power
- 22 – ACC GND
- 23 – Coolant temperature gauge
- 24 – Oil pressure gauge
- 25 – Control unit (Coolant temperature gauge)
- 26 – Control unit (Oil pressure gauge)
- 27 – Conversion harness
- 28 – Wire harness
- 29 – Relay
- 30 – Wire harness for sub panel
- 31 – Water in sail drive seal sensor amplifier (Sail drive only)
- 32 – Procured by customer
- 33 – Battery
- 34 – Battery switch
- 35 – Engine stop solenoid with VE pump
- 36 – Air heater
- 37 – Option (Alternator)
- 38 – Air heater relay
- 39 – Starter relay
- 40 – Starter
- 41 – Coolant temperature switch (to air heater controller)
- 42 – Engine oil pressure switch
- 43 – Alternator
- 44 – Ground
- 45 – Water in sail drive seal sensor (Sail drive only)
- 46 – Coolant temperature sender
- 47 – Oil pressure sender
- 48 – Fuel filter switch
- 49 – Details of coupler (Wire harness, view from A-A)
- 50 – Details of coupler (Conversion harness, view from B-B)

This Page Intentionally Left Blank

EPA WARRANTY USA ONLY

YANMAR CO., LTD. LIMITED EMISSION CONTROL SYSTEM WARRANTY - USA ONLY

3JH5E EPA and ARB Nameplate

EMISSION CONTROL INFORMATION	
THIS ENGINE COMPLIES WITH U.S. EPA MARINE AND CALIFORNIA OFF-ROAD REGULATIONS FOR 2012 M.Y. DIESEL ENGINES. LOW SULFUR FUEL OR ULTRA LOW SULFUR FUEL ONLY.	
ENGINE FAMILY: CYDXN1.64D3N	DISPLACEMENT: 1.642 LITERS
ENGINE MODEL: 3JH5E	E. C. S. : EM DFI
FUEL RATE: 32.5MM ³ STROKE @ 28.7kW / 3000RPM (19skW<37)	
STANDARDS NOx+HC: 7.5g/kW-hr CO: 5.5g/kW-hr PM: 0.30g/kW-hr	
APPLICATION: VARIABLE-SPEED PROPULSION ENGINES USED WITH FIXED-PITCH PROPELLERS.	
YANMAR. YANMAR CO., LTD.	

129271-07711

Figure 1

4JH5E EPA Nameplate For Example (4JH4-TE)

EMISSION CONTROL INFORMATION	
THIS MARINE ENGINE COMPLIES WITH U.S. EPA REGULATIONS FOR 2012.	
ENGINE FAMILY: CYDXN2.19D4N	ENGINE MODEL: 4JH5E
STANDARDS NOx+HC: 7.5g/kW-hr CO: 5.0g/kW-hr PM: 0.30g/kW-hr	
APPLICATION: VARIABLE-SPEED PROPULSION ENGINES USED WITH FIXED-PITCH PROPELLERS.	
EMISSION CONTROL SYSTEM: EM	
REFER TO OWNER'S MANUAL FOR MAINTENANCE SPECIFICATIONS AND ADJUSTMENTS.	
YANMAR. YANMAR CO., LTD.	

129670-07710

Figure 2

4JH4-TE EPA Nameplate

EMISSION CONTROL INFORMATION	
THIS MARINE ENGINE COMPLIES WITH U.S. EPA REGULATIONS FOR 2012.	
ENGINE FAMILY: CYDXN2.00D4T	ENGINE MODEL: 4JH4-TE
STANDARDS NOx+HC: 7.5g/kW-hr CO: 5.0g/kW-hr PM: 0.30g/kW-hr	
APPLICATION: VARIABLE-SPEED PROPULSION ENGINES USED WITH FIXED-PITCH PROPELLERS.	
EMISSION CONTROL SYSTEM: EM	
REFER TO OWNER'S MANUAL FOR MAINTENANCE SPECIFICATIONS AND ADJUSTMENTS.	
YANMAR. YANMAR CO., LTD.	

129671-07710

Figure 3

4JH4-HTE1 EPA Nameplate

EMISSION CONTROL INFORMATION	
THIS MARINE ENGINE COMPLIES WITH U.S. EPA REGULATIONS FOR 2012.	
ENGINE FAMILY: CYDXN2.00D4H	ENGINE MODEL: 4JH4-HTE1
STANDARDS NOx+HC: 7.5g/kW-hr CO: 5.0g/kW-hr PM: 0.30g/kW-hr	
APPLICATION: VARIABLE-SPEED PROPULSION ENGINES USED WITH FIXED-PITCH PROPELLERS.	
EMISSION CONTROL SYSTEM: EM	
REFER TO OWNER'S MANUAL FOR MAINTENANCE SPECIFICATIONS AND ADJUSTMENTS.	
YANMAR. YANMAR CO., LTD.	

129672-07710

Figure 4

EPA WARRANTY USA ONLY

THIS EMISSION WARRANTY APPLIES TO THE ENGINES CERTIFIED TO UNITED STATES EPA 40 CFR AND SOLD BY YANMAR THAT ARE INSTALLED IN VESSELS FLAGGED OR REGISTERED IN THE UNITED STATES.

Your Warranty Rights and Obligations:

Yanmar warrants to the first user and each subsequent purchaser the emission control system on your engine for periods of time listed below provided the engine has been installed according to Yanmar installation requirements and there has been no abuse, neglect, or improper maintenance of your Yanmar Marine engine.

Yanmar warrants that the engine is designed, built and tested using genuine parts and equipped so as to conform to all applicable emission requirements of the U.S. Environmental Protection Agency and is free from defects in material and workmanship which would cause this engine to fail to conform to the applicable emission regulations over its limited emission control system warranty period.

Where a warrantable emissions condition exists, Yanmar will repair your engine at no charge to you for diagnosis, parts, and labor. Warranty service or repair will be provided at authorized Yanmar Marine dealers or distributors.

It is recommended that any replacement parts used for maintenance, repair or replacement of emission control systems are Yanmar parts. The owner may elect to have maintenance, replacement or repair of the emission control components and systems performed by any repair establishment or individual and may elect to use parts other than Yanmar parts for such maintenance, replacement or repair. However, the cost of such service or parts and subsequent failures from such service or parts will not be covered under this emission control system warranty:

Warranty Period:

The warranty starts on either the date of delivery to the first end-user, or the date the unit is first leased, rented, or loaned.

Engine Model	Warranty Period
3JH5E ($19 \leq \text{kW} < 37$)	42 months or 2,500 hours of use, whichever comes first.
4JH5E, 4JH4-TE ($37 \leq \text{kW} < 75$)	60 months or 5,000 hours of use, whichever comes first.
4JH4-HTE1	60 months or 500 hours of use, whichever comes first.

When a measurement device of use hours is not equipped, warranties apply a period of use months.

Warranty Coverage:

Repair or replacement of any warranted parts will be performed at an authorized Yanmar dealer or distributor. This limited emission control system warranty covers engine components that are a part of the emission control system of the engine as delivered by Yanmar to the original retail purchaser. Such components may include the following:

- Fuel Injection System
- Turbocharger System
- After cooler
- Electronic Engine Control Units and its associated Sensor and Actuators

Exclusions:

Failures other than those arising from defects in material and / or workmanship are not covered by this limited emissions warranty. This warranty does not extend to the following: malfunction caused by abuse, misuse, improper adjustment, modification, alteration, tampering, disconnection, improper or inadequate maintenance, improper storage or use of non-recommended fuels and lubricating oils, accident-caused damage, and replacement of expendable and / or consumable items made in connection with scheduled maintenance.

Yanmar disclaims any responsibility for incidental or consequential damages such as loss of time, inconvenience, loss of use of marine vessel / engine or commercial loss.

Owner's Responsibility:

As the Yanmar Marine engine owner, you are responsible for the performance of the required maintenance listed in your *Operation Manual*. Yanmar recommends that you retain all documentation, including receipts, covering maintenance on your marine engine, but Yanmar cannot deny warranty solely for the lack of receipts or for your failure to ensure the performance of all scheduled maintenance.

Your engine is designed to operate on diesel fuel only. Use of any other fuel may result in your engine no longer operating in compliance with applicable emission requirements. You are responsible for initiating the warranty process. You must present your marine engine to an authorized Yanmar dealer or distributor as soon as a problem exists.

Customer Assistance:

If you have any questions regarding your warranty rights and responsibilities or would like information on the nearest authorized Yanmar dealer or distributor, you should contact Yanmar America Corporation, Marine Engine Division for assistance.

Yanmar America Corporation, Marine Engine Division

101 International Parkway
Adairsville, GA 30103 USA
Telephone: 770-877-9894
Fax: 770-877-7567

This Page Intentionally Left Blank

EMISSION SYSTEM WARRANTY

NON-ROAD EMISSION SYSTEM WARRANTY

Yanmar Co., Ltd. Limited Emission Control System Warranty - USA Only

Your Warranty Rights and Obligations:

California

The Air Resources Board (ARB), the Environmental Protection Agency (EPA) and Yanmar Co., Ltd. hereafter referred to as Yanmar, are pleased to explain the emission control system warranty on your compression-ignition engine. In California, model year 2000 or later off-road compression-ignition engines must be designed, built and equipped to meet the State's stringent anti-smog standards. In all states, 1998 and later non-road compression-ignition engines must be designed, built and equipped to meet the United States EPA emissions standards. Yanmar warrants the emission control system on your engine for the periods of time listed below provided there has been no abuse, neglect or improper

maintenance of your engine.

Your emission control system may include parts such as the fuel injection system and the air induction system.

Where a warrantable condition exists, Yanmar will repair your non-road compression-ignition engine at no charge to you including diagnosis, parts and labor.

Manufacturer's Warranty Period:

The model year 1998 or later certified and labeled non-road compression-ignition engines are warranted for the periods listed below. If any emission-related part on your engine is found to be defective during the applicable warranty period, the part will be replaced by Yanmar.

Engine Model	Warranty Period
3JH5E (19 ≤ kW < 37)	42 months or 2,500 hours of use, whichever comes first.

When a measurement device of use hours is not equipped, warranties apply a period of use months.

EMISSION SYSTEM WARRANTY

Warranty Coverage:

This warranty is transferable to each subsequent purchaser for the duration of the warranty period. Repair or replacement of any warranted part will be performed at an authorized Yanmar Marine engine dealer or distributor.

Warranted parts not scheduled for replacement as required maintenance in the *Operation Manual* shall be warranted for the warranty period. Warranted parts scheduled for replacement as required maintenance in the operation manual are warranted for the period of time prior to the first scheduled replacement. Any part repaired or replaced under warranty shall be warranted for the remaining warranty period.

During the warranty period, Yanmar is liable for damages to other engine components caused by the failure of any warranted part during the warranty period.

Any replacement part which is functionally identical to the original equipment part in all respects may be used in the maintenance or repair of your engine, and shall not reduce Yanmar's warranty obligations. Add-on or modified parts that are not exempted may not be used. The use of any non-exempted add-on or modified parts shall be grounds for disallowing a warranty.

Warranted Parts:

This warranty covers engine components that are a part of the emission control system of the engine as delivered by Yanmar to the original retail purchaser. Such components may include the following:

- Fuel Injection System
- Cold Start Enrichment System
- Positive Crankcase Ventilation System

Since emissions-related parts may vary slightly between models, certain models may not contain all of these parts and other models may contain the functional equivalents.

Exclusions:

Failures other than those arising from defects in material and / or workmanship are not covered by this warranty. The warranty does not extend to the following: malfunctions caused by abuse, misuse, improper adjustment, modification, alteration, tampering, disconnection, improper or inadequate maintenance or use of non-recommended fuels and lubricating oils; accident-caused damage, and replacement of expendable items made in connection with scheduled maintenance. Yanmar disclaims any responsibility for incidental or consequential damages such as loss of time, inconvenience, loss of use of equipment / engine or commercial loss.

Owners Warranty Responsibilities:

As the engine owner, you are responsible for the performance of the required maintenance listed in your owner's manual. Yanmar recommends that you retain all documentation, including receipts, covering maintenance on your non-road compression-ignition engine, but Yanmar cannot deny warranty solely for the lack of receipts, or for your failure to ensure the performance of all scheduled maintenance.

Yanmar may deny your warranty coverage of your non-road compression-ignition engine if a part has failed due to abuse, neglect, improper maintenance or unapproved modifications.

Your engine is designed to operate on diesel fuel only. Use of any other fuel may result in your engine no longer operating in compliance with applicable emissions requirements.

You are responsible for initiating the warranty process. You must present your engine to a Yanmar dealer as soon as a problem exists. The warranty repairs should be completed by the dealer as expeditiously as possible.

Customer Assistance

If you have any questions regarding your warranty rights and responsibilities or would like information on the nearest authorized Yanmar dealer or distributor, you should contact Yanmar Marine USA Corporation for assistance.

Yanmar America Corporation, Marine Engine Division

101 International Parkway
Adairsville, GA 30103 USA
Telephone: 770-877-9894
Fax: 770-877-7567

EMISSION SYSTEM WARRANTY

Maintenance Log

Date	Operating Hours	Maintenance Performed	Dealer Name	Stamp or Signature

EMISSION SYSTEM WARRANTY

1507

Date	Operating Hours	Maintenance Performed	Dealer Name	Stamp or Signature

EMISSION SYSTEM WARRANTY

Declaration of Conformity for Recreational Craft Propulsion Engine with the Exhaust emission requirements of Directive 94/25/EC as amended by 2003/44/EC (To be completed by manufacturer of inboard engines without integral exhaust)

Name of engine manufacturer: Yanmar Co., Ltd.

Street: 1-32 Town: Chayamachi, Kitaku, Osaka-City

Post Code: 530-8311 Country: Japan

Name of Authorised Representative: Yanmar Co.,Ltd. Marine Operations Division

Street: 5-3-1 Town: Tsukaguchi Honmachi, Amagasaki, Hyogo

Post Code: 661-0001 Country: Japan

Name of Notified Body for exhaust emission assessment: Société Nationale de Certification et d'Homologation

Street: 11, route de Luxembourg Town: Sandweiler

Post Code: L-5230 Country: Luxembourg ID Number: 0499

Module used for exhaust emission assessment: B+C B+D B+E B+F G H

or engine type-approved according to: stage II of Directive 97/68/EC Directive 88/77/EC

Other Community Directives applied: 2004/108/EC

DESCRIPTION OF ENGINE(S) AND ESSENTIAL REQUIERMENTS

Engine Type: z or sterndrive without integral exhaust Inboard engine

Fuel Type: Diesel Petrol

Combustion cycle: 2 stroke 4 stroke

Essential requirements	Standards Used	Other normative document used	See technical file
Annex I.B – Exhaust Emissions			
engine identification			
exhaust emission requirements	EN ISO 8178-1:1996		X
durability			
owner's manual			
Annex I.C – Noise Emissions	see craft manufacturer's Declaration of Conformity		

ENGINE(S) COVERED BY THIS DECLARATION

Engine model(s) or engine family name(s):	EC Type certificate number (exhaust)
	SNCH*94/25*2003/44*
RCD-1GM10X1	0009*00
RCD-2YM15X1	0004*02
RCD-3YM30X1	0005*02
RCD-4JH4X1	0014*01
RCD-4JH3TX1	0011*01
RCD-4LHAX1	0015*00
RCD-6LPADX1	0012*00
RCD-6LPASX1	0007*00
RCD-6CXMX1	0006*00
RCD-6LY2X1	0008*00
RCD-6LY3X1	0010*04
RCD-4JH3TX2	0016*00
RCD-4JH4TX2	0017*01
RCD-4JH4TX1	0018*02
RCD-6LPASX2	0023*01
RCD-4JH4AX1	0025*02
RCD-6CX53X1	0028*01
RCD-4JH5X1	0029*00
RCD-3JH5X1	0030*00
RCD-8LVX1	0038*00

I declare on behalf of the engine manufacturer that the engine(s) will meet the exhaust emission requirements of Directive 94/25/EC as amended by Directive 2003/44/EC when installed in a recreational craft, in accordance with the engine manufacturer's supplied instructions and that this (these) engine(s) must not be put into service until the recreational craft into which it is (they are) to be installed has been declared in conformity with the relevant provisions of the above mentioned Directive.

Name: Mitsuo Kaji Signature and title: M. Kaji
(identification of the person empowered to sign on behalf of the engine manufacturer or his authorised representative) (or an equivalent marking) Senior Manager
Small Marine Engine Development Dept.
Marine Operations Division
Yanmar Co., Ltd.

Date: (yr/month/day) 2011 / 11 / 11

YANMAR CO.,LTD.

■ Yanmar (Head office)

1-32, Chayamachi, Kita-ku, Osaka, Japan 530-8311

■ Marine Operations Division

Quality Assurance Dept.

3-1, 5-Chome, Tsukaguchi-honmachi, Amagasaki,
Hyogo, Japan 661-0001
Phone: 81-6-6428-3251 Fax: 81-6-6421-5549

Overseas Office

■ Yanmar Europe B.V. (YEU)

Brugplein 11, 1332 BS Almere-de Vaart, Netherlands
Phone: 31-36-5493200 Fax: 31-36-5493209

■ Yanmar Asia (Singapore) Corporation Pte Ltd. (YASC)

4 Tuas Lane, Singapore 638613
Phone: 65-6595-4200 Fax: 65-6862-5189

■ Yanmar America Corporation (YA)

101 International Parkway
Adairsville, GA 30103, U.S.A.
Phone: 1-770-877-9894 Fax: 1-770-877-9009

■ Yanmar Engine (Shanghai). Co., Ltd.

10F, E-Block POLY PLAZA, No.18 Dongfang Road,
Pudong Shanghai, CHINA P.R.C 200120
Phone: 21-6880-5090 Fax: 21-6880-8090

OPERATION MANUAL

3JH5E, 4JH5E, 4JH4-TE, 4JH4-HTE1, 4JH4-HTE

Aug 2009: 1st edition
Dec 2011: 2nd edition

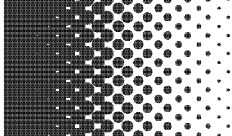

MARINE ENGINES



YANMAR

YANMAR CO.,LTD.

<http://www.yanmar.co.jp>

0AJHM-M00201
PRINTED IN JAPAN