

DETAIL OF COUPLING
SCALE 1/3

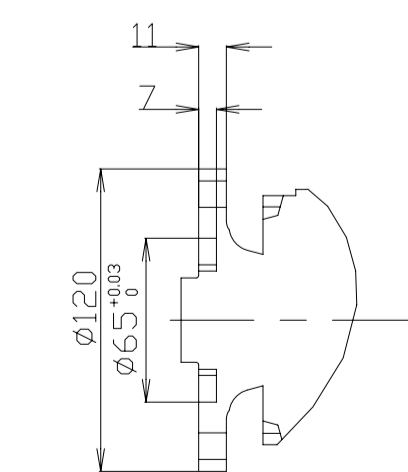

SECTION A-A

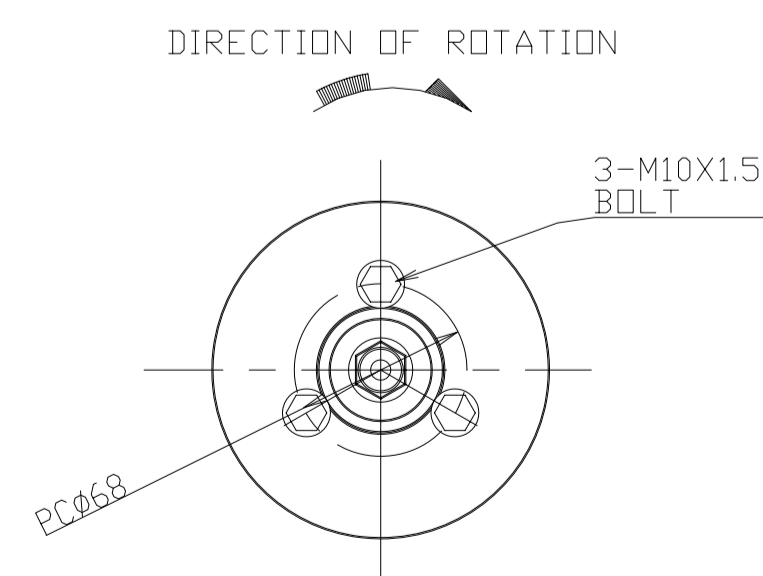

DETAIL OF PULLEY
SCALE 1:3
ARROW A

- NOTE
- 1.DWG.SHOWS MOUNTING BLOCKS AT ORIGINAL HEIGHT. ENGINE WEIGHT WILL COMPRESS BLOCKS BY 4MM(APPROX).
 - 2.MOUNTING BLOCKS ARE EQUIPPED FOR STANDARD ACCESSORY.
 - 3.THE FIGURES MARKED WITH * SHOW THE DIMENSIONS WITH U-MIXING ELBOW, OR OPTIONAL COUPLING.
 4. ● SHOWS THE CENTER OF GRAVITY.

SPECIFICATIONS			
Model			4JH4-TE
Continuous Power(ISO 8665)	kW/min ⁻¹		50.2/3101
Fuel Stop Power	Propeller shaft(ISO 8665)	kW/min ⁻¹	53.0/3200
	Crankshaft(ISO 8665)	kW/min ⁻¹	55.2/3200
Reduction ratio		1.47 2.14 2.63	
Dry mass	kg(lb.)	Approx. 232(511)	
Direction of Crankshaft rotation			Counter-clockwise

SCALE	NAME	MODEL
1:5	OUTLINE	4JH4-TE×KM4A2
DATE	ORIGINAL DRAWING NUMBER	REVISION
11-26-2012	B2-29671-0851	0