

NOTICE
THE MOUNTING FLANGE WIDTH
OF TRANSMISSION SHOULD BE 445.

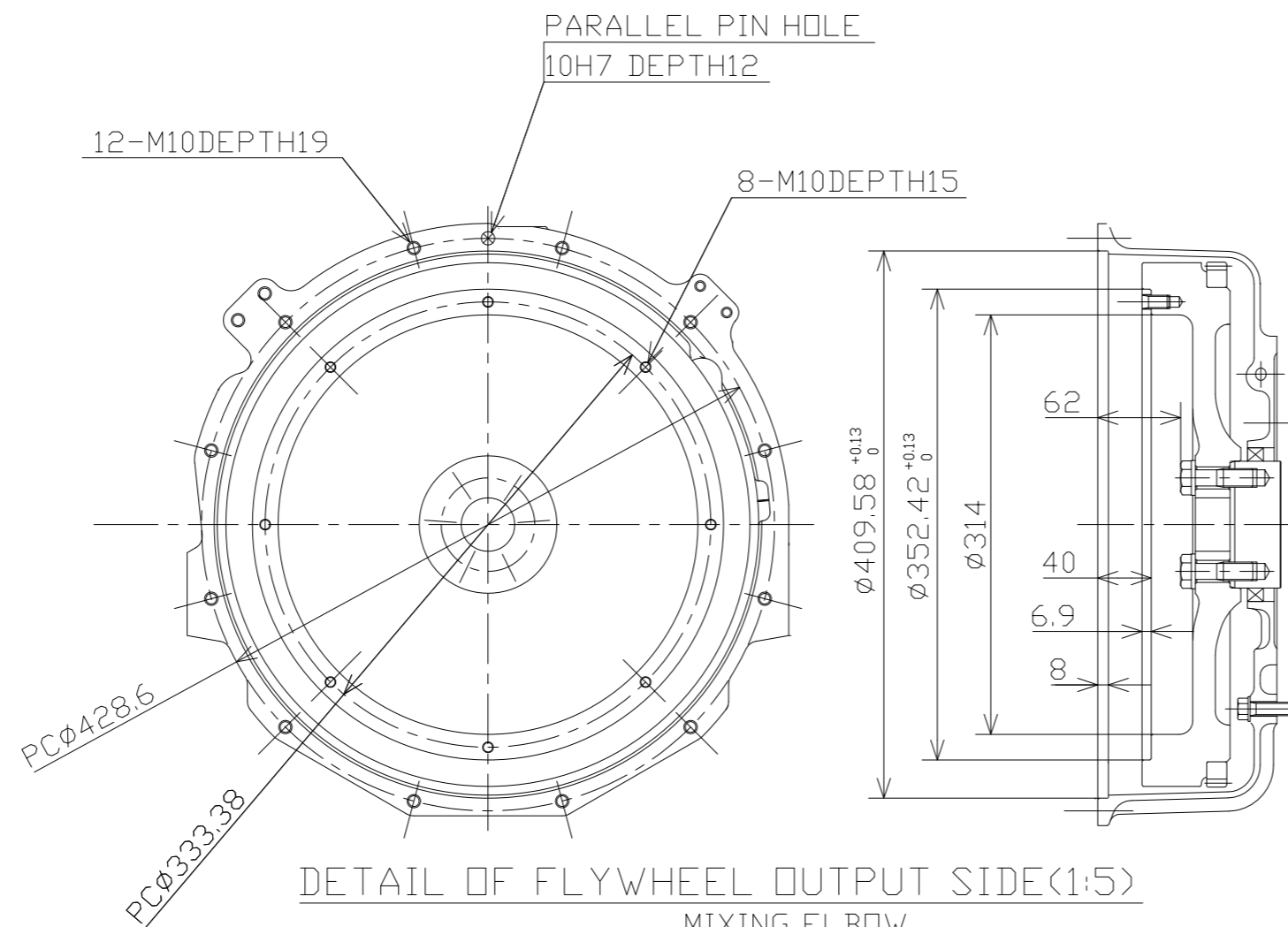

DETAIL OF FLYWHEEL OUTPUT SIDE(1:5)

MIXING ELBOW
:V-BAND TYPE AT EXHAUST INLET.
:ALLOWABLE INSTALLATION ANGLE
BETWEEN 0° TO 90° DEGREE.

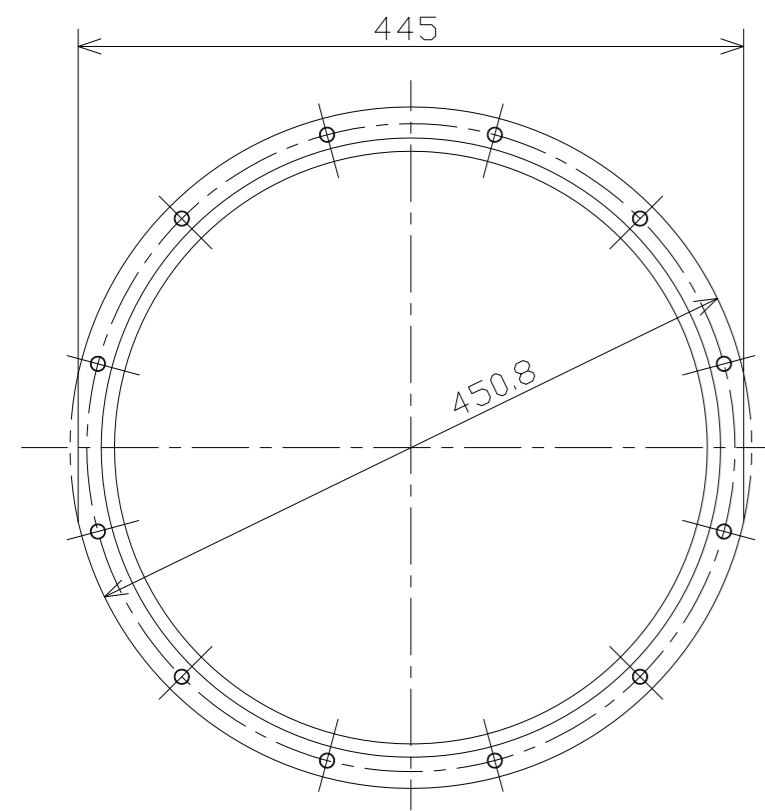
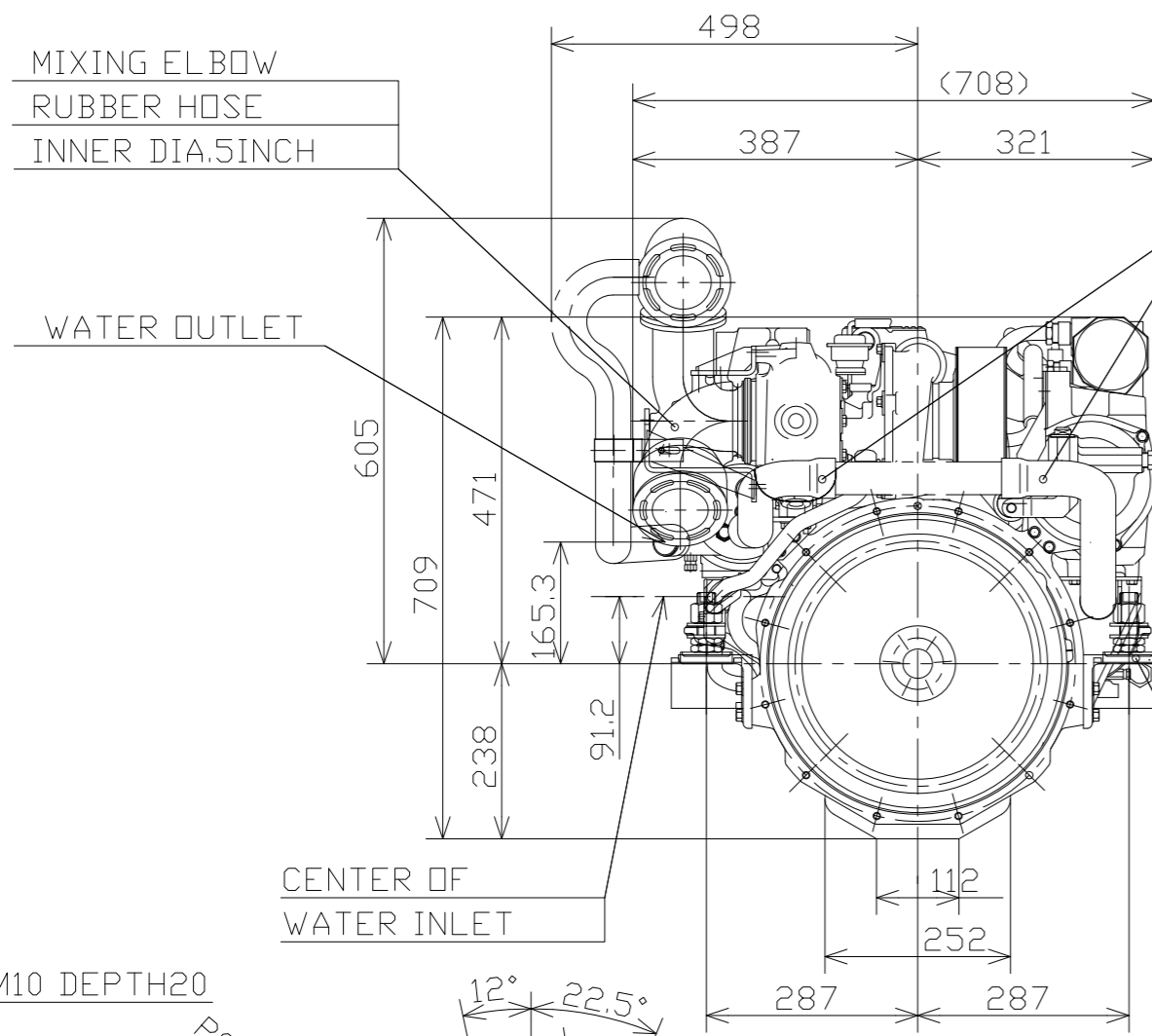
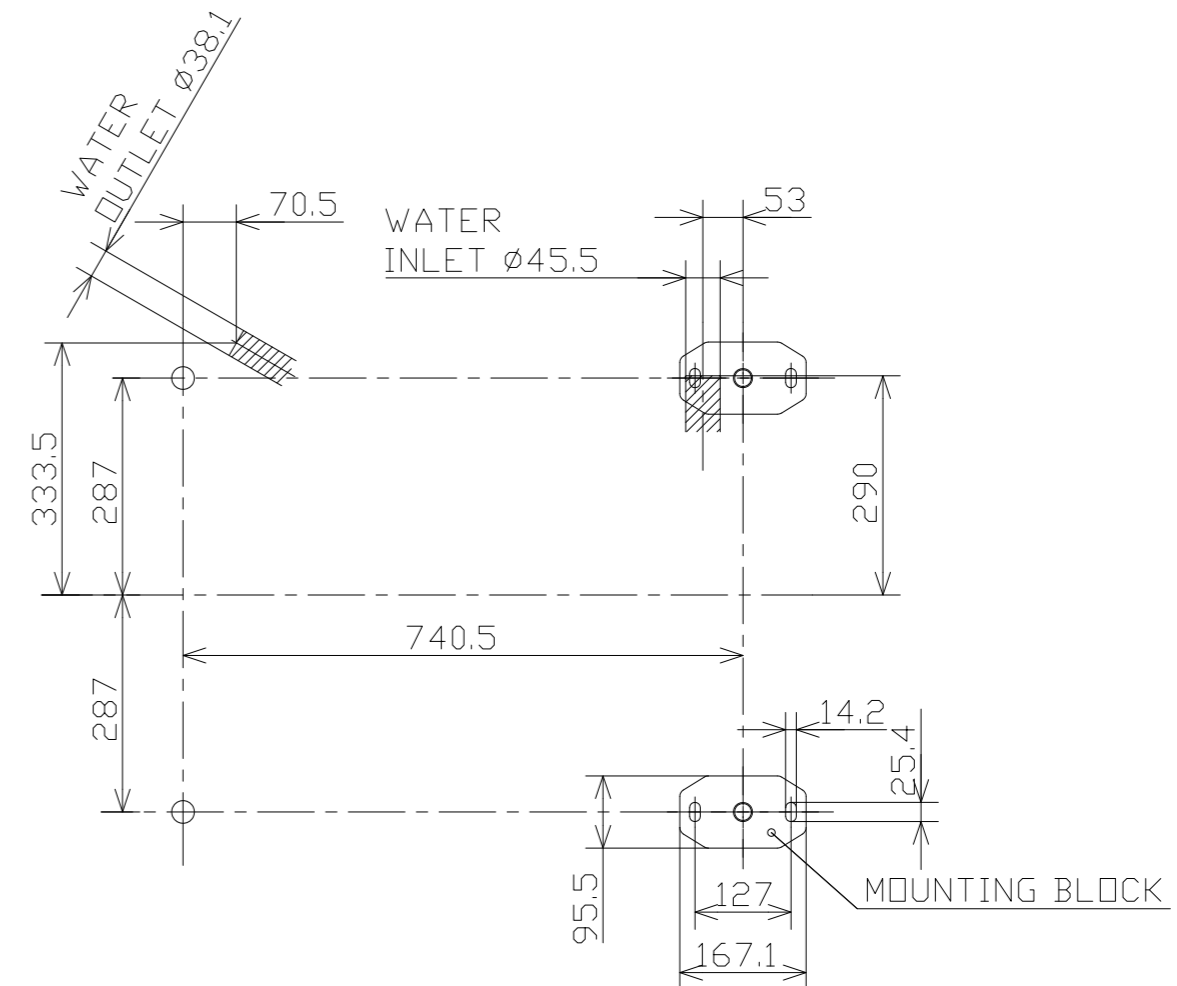

THESE RUBBER HOSES SHOULD
BE CONNECTED TO THE OILCOOLER
OF MARINE GEAR.
WATER PASSAGE AREA IS
OVER 12.5cm².

DIRECTION OF ROTATION

MOUNTING BRACKETS(REAR SIDE)
SHOULD BE USED ONLY FOR
TRANSPORTATION.

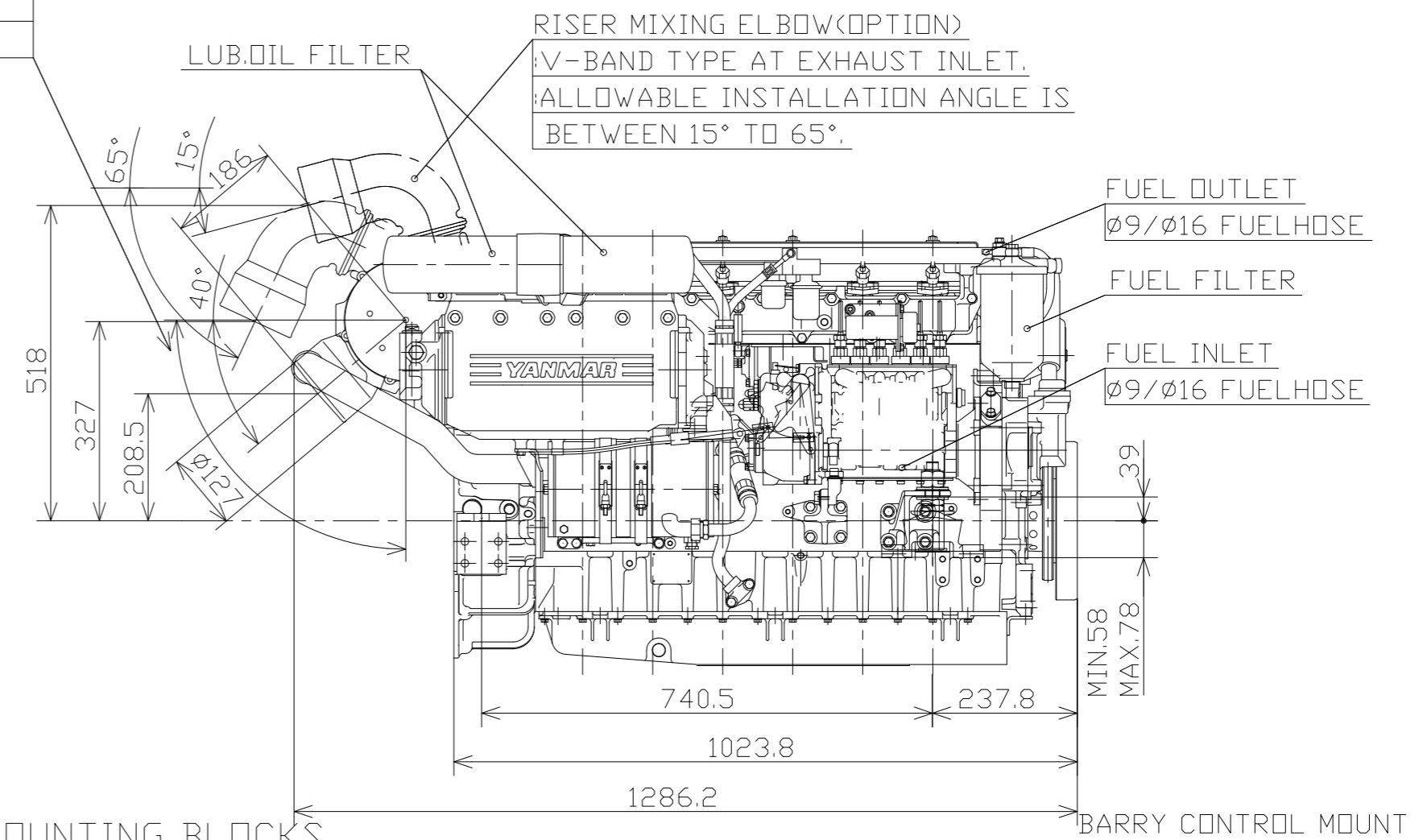

RISER MIXING ELBOW(OPTION)
:V-BAND TYPE AT EXHAUST INLET.
:ALLOWABLE INSTALLATION ANGLE IS
BETWEEN 15° TO 65°.

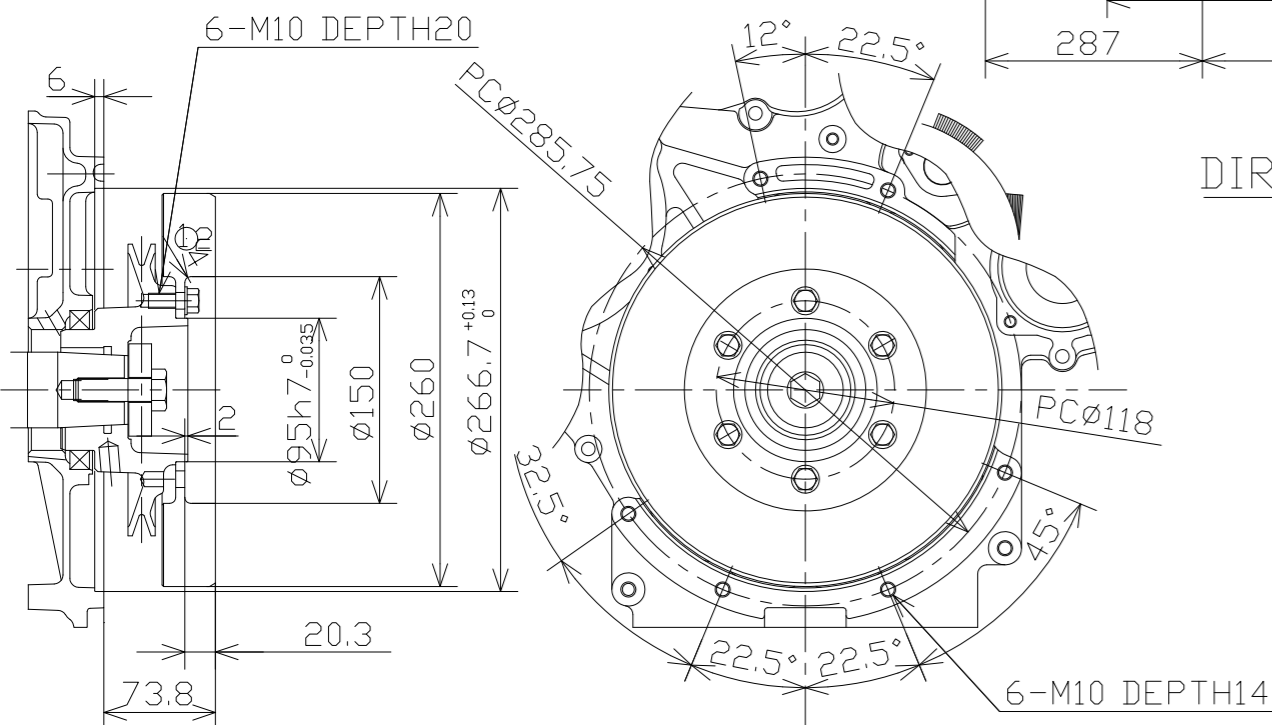

DETAIL OF FRONT COUPLING(1:5)

DIRECTION OF ROTATION

NOTE
1.DWG. SHOWS MOUNTING BLOCKS
AT COMPRESSED HEIGHT.
(COMPRESSED BY APPROX 2mm)
2.MOUNTING BLOCK PARTS NUMBER IS
119773-08300

SPECIFICATIONS		
MODEL		6LY2A-STP
CONT. RATING OUTPUT (FLYWHEEL OUTPUT)	HP/rpm	350/3100
	kW/rpm	257/3100
MAX OUTPUT (FLYWHEEL OUTPUT)	HP/rpm	440/3300
	kW/rpm	324/3300
NUMBER OF CYLINDER		6
DRY WEIGHT	kg	535
DIRECTION OF CRANK.SHAFT ROTATION		COUNTER CLOCKWISE AT FLYWHEEL SIDE

SCALE	NAME	MODEL
1:10(1:5)	OUTLINE	6LY2A-STP
DATE	ORIGINAL DRAWING NUMBER	REVISION
2-13-2002	B2-19575-0500	0