

*NOTE: The following applies to CE marked products only.*

## Declaration of Conformance – Mercury MerCruiser

This sterndrive or inboard engine when installed in accordance to Mercury MerCruisers' instructions complies with the requirements of the following directives by meeting the associated standards, as amended:

Recreational Craft Directive 94/25/EC; 2003/44/EC

Applicable Requirement	Standards Applied
Owner's manual (A.2.5)	ISO 10240
Openings in Hull, Deck and superstructure (A.3.4)	ISO 9093-1; ISO 9093-2
Handling characteristics (A.4)	ISO 8665
Inboard Engine (A.5.1.1)	ISO 15584; ISO 10088; ISO 7840; ISO 10133
Fuel System (A.5.2)	ISO 10088; ISO 7840; ISO 8469
Electrical System (A.5.3)	ISO 10133; ISO 8846
Steering system (A.5.4)	Applicable portions of: ISO 10592, ISO 8848 and ABYC P-17
Exhaust emission requirements (B.2)	ISO 8178
Owner's manual (B.4)	ISO 8665
Noise emission levels (C.1)	ISO 14509
Ignition-protected equipment (Annex II)	ISO 8846; SAE J1171; SAE J1191; SAE J 2031

Mercury MerCruiser declares that our sterndrive or inboard engines without integral exhaust, when installed in a recreational craft, in accordance with the manufacturers supplied instructions, will meet the exhaust emissions requirements of the directive mentioned above. This engine must not be put into service until the recreational craft in which it is to be installed has been declared in conformity, if so required, with the relevant provision of the directive.

Electromagnetic Compatibility Directive 89/336/EC, 92/31/EEC and 93/68/EEC

Generic emission standard	EN 50081-1
Generic immunity standard	EN 50082-1
Vehicles, boats and internal combustion engine driven devices - Radio disturbance characteristics	SAE J551 (CISPR 12)
Electrostatic discharge testing	EN 61000-6-2; EN 61000-4-2; EN61000-4-3

The notified body responsible for surveillance of the quality system under Full Quality Assurance Module H of Directive 2003/44/EC is:

Det Norske Veritas  
Norway  
Notified Body Number: 0575

This declaration is issued under the sole responsibility of Mercury Marine and Mercury MerCruiser.



Patrick C. Mackey

President - Mercury Marine, Fond du Lac, WI USA

Regulatory contact:  
 Engineering - Regulatory  
 MerCruiser  
 3003 N. Perkins Rd  
 Stillwater, Oklahoma 74075  
 USA  
 (405) 377-1200

## Identification Record

Please record the following information:

Engine Model and Horsepower		Engine Serial Number
Transom Assembly Serial Number (Sterndrive)	Gear Ratio	Sterndrive Unit Serial Number
Transmission Model (Inboard)	Gear Ratio	Transmission Serial Number
Propeller Number	Pitch	Diameter
Hull Identification Number (HIN)		Purchase Date
Boat Manufacturer	Boat Model	Length
Exhaust Gas Emissions Certification Number		

The serial numbers are the manufacturer's keys to numerous engineering details that apply to your Mercury MerCruiser® power package. When contacting your Authorized Mercury MerCruiser Dealer about service, **always specify model and serial numbers.**

The description and specifications contained herein were in effect at the time this guide was approved for printing. Mercury Marine, whose policy is one of continuous improvement, reserves the right to discontinue models at any time, or to change specifications or designs, without notice and without incurring obligation.

Mercury Marine, Fond du Lac, Wisconsin, U.S.A. Printed in U.S.A.

©2006, Mercury Marine

Mercury, Mercury Marine, MerCruiser, Mercury MerCruiser, Mercury Racing, Mercury Precision Parts, Mercury Propellers, Mariner, Quicksilver, #1 On The Water, Alpha, Bravo, Pro Max, OptiMax, Sport-Jet, K-Planes, MerCathode, RideGuide, SmartCraft, Zero Effort, M with Waves logo, Mercury with Waves logo, and SmartCraft logo are all registered trademarks of Brunswick Corporation. Mercury Product Protection logo is a registered service mark of Brunswick Corporation.

## Welcome

You have selected one of the finest marine power packages available. It incorporates numerous design features to assure operating ease and durability.

With proper care and maintenance, you will thoroughly enjoy using this product for many boating seasons. To ensure maximum performance and carefree use, we ask that you thoroughly read this manual.

The Operation, Maintenance and Warranty Manual contains specific instructions for using and maintaining your product. We suggest that this manual remain with the product for ready reference whenever you are on the water.

Thank you for purchasing one of our Mercury MerCruiser products. We sincerely hope your boating will be pleasant!

Mercury MerCruiser

## Warranty Message

The product you have purchased comes with a **limited warranty** from Mercury Marine; the terms of the warranty are set forth in the Warranty Sections of this manual. The warranty statement contains a description of what is covered, what is not covered, the duration of coverage, how to best obtain warranty coverage, **important disclaimers and limitations of damages** and other related information. Please review this important information.

Mercury Marine products are designed and manufactured to comply with our own high quality standards, applicable industry standards and regulations, as well as certain emissions regulations. At Mercury Marine every engine is operated and tested before it is boxed for shipment to make sure that the product is ready for use. In addition, certain Mercury Marine products are tested in a controlled and monitored environment, for up to 10 hours of engine run time, in order to verify and make a record of compliance with applicable standards and regulations. All Mercury Marine product, sold as new, receives the applicable limited warranty coverage, whether the engine participated in one of the test programs described above or not.

## Read This Manual Thoroughly

**IMPORTANT: If you don't understand any portion of this manual, contact your dealer for a demonstration of actual starting and operating procedures.**

## Notice

Throughout this publication, and on your power package, dangers, warnings, cautions, and notices, accompanied by the International Hazard Symbol , may be used to alert the installer/user to special instructions concerning a particular service or operation that may be hazardous if performed incorrectly or carelessly. These safety alerts follow ANSI standard Z535.6-2006 for product safety information in product manuals, instructions, and other collateral materials. **Observe them carefully.**

These Safety Alerts alone cannot eliminate the hazards that they signal. Strict compliance with these special instructions while performing the service, plus common sense operation, are major accident prevention measures.

### DANGER

Indicates a hazardous situation which, if not avoided, will result in death or serious injury.

### WARNING

Indicates a hazardous situation which, if not avoided, could result in death or serious injury.

### CAUTION

Indicates a hazardous situation which, if not avoided, could result in minor or moderate injury.

## NOTICE

Indicates a situation which, if not avoided, could result in engine or major component failure.

**IMPORTANT:** Identifies information essential to the successful completion of the task.

*NOTE:* Indicates information that helps in the understanding of a particular step or action.

## WARNING

The operator (driver) is responsible for the correct and safe operation of the boat, the equipment aboard and the safety of all occupants aboard. We strongly recommend that the operator read this Operation, Maintenance and Warranty Manual and thoroughly understand the operational instructions for the power package and all related accessories before the boat is used.

## WARNING

The engine exhaust from this product contains chemicals known to the state of California to cause cancer, birth defects or other reproductive harm.

# TABLE OF CONTENTS

---

## Section 1 - Warranty

---

Warranty Registration: United States and Canada.....	2	Mercury Installation Quality Certification Program	10
Warranty Registration: Outside the United States and Canada.....	2	California Emissions Limited Warranty.....	11
Transfer of Warranty.....	3	What Is Covered.....	11
Mercury Product Protection Plan: United States and Canada.....	3	Duration Of Coverage.....	12
Mercury MerCruiser Limited Warranty (Gasoline-Fueled Products Only) .....	4	How To Obtain Warranty Coverage.....	12
3-Year Limited Warranty Against Corrosion.....	6	What Mercury Will Do.....	13
4-Year Limited Corrosion Warranty: SeaCore Sterndrive Models with Gas Engines .....	7	What Is Not Covered.....	13
Global Warranty Charts.....	8	Components Of The Emission Control System	13
Consumer Application Warranty Chart.....	8	Disclaimers And Limitations.....	14
Commercial Application Warranty Chart.....	9	California Emission Control Warranty Statement. .	14
Government Application Warranty Chart.....	10	Your Warranty Rights and Obligations.....	14
		Manufacturer's Warranty Coverage.....	14
		Owner's Warranty Responsibilities.....	15
		Emission Control Information Label.....	15
		Owner Responsibility.....	16
		Emission Certification Star Label.....	16

---

## Section 2 - Getting to Know Your Power Package

---

Lanyard Stop Switch.....	20	Console Mount Features.....	24
Instrumentation.....	21	Zero Effort Features.....	24
System View.....	21	Electrical System Overload Protection.....	25
Digital Gauges.....	22	Audio Warning System.....	26
Analog Gauges.....	22	Testing The Audio Warning System.....	27
Remote Controls.....	22	Engine Guardian Strategy.....	27
Panel Mount Features.....	23	Warning Horn Signals.....	27

---

## Section 3 - On The Water

---

Safe Boating Suggestions.....	30	High-Speed And High-Performance Boat Operation.....	35
Be Alert To Carbon Monoxide Poisoning.....	31	Passenger Safety In Pontoon Boats And Deck Boats.....	35
Good Ventilation.....	32	Boats Having An Open Front Deck.....	35
Poor Ventilation .....	32	Boats With Front-Mounted, Raised Pedestal Fishing Seats.....	36
Basic Boat Operation.....	32	Wave And Wake Jumping.....	36
Launching and Boat Operation.....	32	Impact With Underwater Hazards.....	37
Operation Chart.....	32	Conditions Affecting Operation.....	37
Starting and Stopping the Scorpion Engine. .	33	Weight Distribution (Passengers and Gear) Inside the Boat.....	37
Starting the Engine.....	33	Bottom Of Boat.....	38
Stopping the Engine.....	34	Cavitation.....	38
Throttle Only Operation.....	34	Ventilation.....	38
Freezing Temperature Operation.....	34	Elevation And Climate.....	38
Drain Plug and Bilge Pump.....	34		
Protecting People In The Water.....	34		
While You Are Cruising.....	34		
While Boat Is Stationary.....	35		

---

Propeller Selection.....	39	After Break-In Period.....	39
Getting Started.....	39	End of First Season Checkup.....	40
20-Hour Break-In Period.....	39		

---

## Section 4 - Specifications

---

Fuel Requirements.....	42	Engine Oil.....	43
Fuel Ratings.....	42	Engine Specifications: Scorpion.....	44
Using Reformulated (Oxygenated) Gasolines (USA Only).....	42	Fluid Specifications.....	44
Gasolines Containing Alcohol.....	42	Engine.....	44
		Transmission.....	45

---

## Section 5 - Maintenance

---

Owner/Operator Responsibilities.....	48	Changing Filter.....	55
Dealer Responsibilities.....	48	Transmission Fluid.....	56
Maintenance.....	48	Checking While the Engine is Warm.....	56
Do It Yourself Maintenance Suggestions.....	49	Checking While Engine is Cold.....	56
Inspection.....	49	Changing.....	56
Maintenance Schedule - Inboard Models.....	50	IAC Muffler.....	56
Routine Maintenance.....	50	Changing.....	56
Each Day Start.....	50	Cleaning The Flame Arrestor.....	56
Each Day End.....	50	Positive Crankcase Ventilation Valve (PCV) ...	57
Weekly.....	50	Changing.....	57
Every Two Months or 50 Hours.....	50	Changing Water Separating Fuel Filter.....	58
Scheduled Maintenance.....	50	In-line Fuel Filter.....	59
After the Initial 20 Hour Break-in.....	50	Lubrication.....	61
Every 100 Hours or Annually (Whichever Occurs First).....	50	Throttle Cable.....	61
Every 300 Hours or 3 Years.....	50	Transmission Linkage.....	61
Every 5 Years.....	51	Serpentine Drive Belt.....	63
Maintenance Log.....	51	Checking.....	63
Engine Oil.....	51	Replacing Belt and/or Adjusting Tension.....	63
Checking.....	52	Flushing The Power Package—Tow Sports.....	64
Filling.....	52	The Boat Out of the Water.....	64
Changing Oil and Filter.....	53	The Boat In the Water.....	66
Easy Engine Oil Drain System.....	54	Battery.....	68
Engine Oil Drain Pump.....	54	Multiple EFI Engine Battery Precautions.....	69

---

## Section 6 - Storage

---

Cold Weather or Extended Storage.....	72	Multi-Point Drain (MPD) System.....	76
Preparing Power Package for Storage.....	72	Air Actuated Single Point Drain System.....	76
Engine and Fuel System Preparation.....	73	Boat in the Water.....	76
Draining the Seawater System.....	74	Boat out of the Water.....	79
Drain System Identification.....	74	Manual Single Point Drain System.....	81
Air Actuated Single Point Drain System.....	74	Boat in the Water.....	81
Manual Single Point Drain System.....	75	Boat out of the Water.....	82
Three Point Manual Drain System.....	75		

Three Point Manual Drain System.....	83	Boat out of the Water.....	85
Boat in the Water.....	83	Boat in the Water.....	87
Boat out of the Water.....	84	Battery Storage.....	89
Multi-Point Drain (MPD) System.....	85	Power Package Recommissioning.....	89

## Section 7 - Troubleshooting

Diagnosing EFI Problems.....	92	Excessive Engine Temperature.....	93
Engine Guardian System.....	92	Insufficient Engine Temperature.....	93
Starter Motor Will Not Crank Engine, Or Cranks Slow.....	92	Low Engine Oil Pressure.....	93
Engine Will Not Start Or Is Hard To Start.....	92	Battery Will Not Come Up On Charge.....	94
Engine Runs Rough, Misses And/Or Backfires....	92	Remote Control Operates Hard, Binds, Has Excessive Free-play Or Makes Unusual Sounds. .	94
Poor Performance.....	93	Steering Wheel Turns Hard Or Jerky.....	94

## Section 8 - Customer Assistance Information

Owner Service Assistance.....	96	Parts And Accessories Inquiries.....	97
Local Repair Service.....	96	Resolving A Problem.....	97
Service Away From Home.....	96	Mercury Marine Service Offices.....	97
Stolen Power Package.....	96	Ordering Literature.....	98
Attention Required After Submersion.....	96	United States and Canada.....	98
Replacement Service Parts.....	96	Outside The United States and Canada.....	98





# Section 1 - Warranty

## Table of Contents

Warranty Registration: United States and Canada .....	2	California Emissions Limited Warranty.....	11
.....	2	What Is Covered .....	11
Warranty Registration: Outside the United States and Canada.....	2	Duration Of Coverage .....	12
Transfer of Warranty.....	3	How To Obtain Warranty Coverage .....	12
Mercury Product Protection Plan: United States and Canada.....	3	What Mercury Will Do .....	13
Mercury MerCruiser Limited Warranty (Gasoline-Fueled Products Only) .....	4	What Is Not Covered .....	13
3-Year Limited Warranty Against Corrosion.....	6	Components Of The Emission Control System .....	13
4-Year Limited Corrosion Warranty: SeaCore Sterndrive Models with Gas Engines .....	7	Disclaimers And Limitations .....	14
Global Warranty Charts.....	8	California Emission Control Warranty Statement .....	14
Consumer Application Warranty Chart .....	8	Your Warranty Rights and Obligations .....	14
Commercial Application Warranty Chart .....	9	Manufacturer's Warranty Coverage .....	14
Government Application Warranty Chart .....	10	Owner's Warranty Responsibilities .....	15
Mercury Installation Quality Certification Program .....	10	Emission Control Information Label.....	15
.....	10	Owner Responsibility .....	16
		Emission Certification Star Label.....	16

## Warranty Registration: United States and Canada

To ensure that your warranty coverage begins promptly, your selling dealer should fill out the Warranty Registration Card completely and mail it to the factory immediately upon sale of the new product.

The Warranty Registration Card identifies the name and address of the original purchaser, product model and serial number(s), date of sale, type of use and selling dealer's code, name, and address. The dealer also certifies that you are the original purchaser and user of the product. A temporary Owner Warranty Registration Card will be presented to you when you purchase the product.

Upon receipt of the Warranty Registration Card at the factory, Mercury MerCruiser will send you an owner resource guide that includes your warranty registration confirmation. If you do not receive your owner resource guide within 60 days from date of new product sale, please contact your selling dealer.

Because of your selling dealer's ongoing interest in your satisfaction, the product should be returned to him for warranty service.

The product warranty is not effective until the product is registered at the factory.

***NOTE: Registration lists must be maintained by the factory and dealer on marine products sold in the United States in the event that a safety recall notification under the Federal Boat Safety Act is required.***

You may change your address at any time, including at time of warranty claim, by calling Mercury MerCruiser or sending a letter or fax to Mercury MerCruiser's warranty registration department with your name, old address, new address, and engine serial number. Your dealer can also process this change of information.

United States customers or dealers may contact:

Mercury Marine  
Attn: Warranty Registration Department  
W6250 Pioneer Road  
P.O. Box 1939  
Fond du Lac, WI 54936-1939  
920-929-5054  
Fax 920-929-5893

Canadian customers or dealers may contact:

Mercury Marine Canada Limited  
2395 Meadowpine Blvd.  
Mississauga, ON  
Canada, L5N 7W6  
Fax 1-800-663-8334

## Warranty Registration: Outside the United States and Canada

To ensure that your warranty coverage begins promptly, your selling dealer should fill out the warranty registration card completely and mail it to the distributor responsible for administering the warranty registration and claim program for your area.

The warranty registration card identifies your name and address, product model and serial numbers, date of sale, type of use, and the selling distributor's and dealer's code number, name, and address. The distributor or dealer also certifies that you are the original purchaser and user of the product. A copy of the warranty registration card, designated as the purchaser's copy, **MUST** be given to you immediately after the card has been completely filled out by the selling distributor or dealer. This card represents your factory registration identification. Keep the card; if you ever need warranty service on this product, your dealer may ask you for the warranty registration card to verify date of purchase and to use the information on the card to prepare the warranty claim forms.

In some countries, the distributor will issue a permanent (plastic) warranty registration card to you within 30 days after receiving the factory copy of the warranty registration card from your distributor or dealer. If you receive a plastic warranty registration card, you may discard the purchaser's copy that you received from the distributor or dealer when you purchased the product. Ask your distributor or dealer if this plastic card program applies to you. For further information concerning the warranty registration card and its relationship to warranty claim processing, refer to the International Warranty. See Table of Contents.

***NOTE: Registration lists must be maintained by the factory and dealer on marine products sold in the United States in the event of a safety recall notification under the Federal Boat Safety Act.***

## Transfer of Warranty

The limited warranty is transferable to a subsequent purchaser, but only for the remainder of the unused portion of the limited warranty. This will not apply to products used for commercial applications.

To transfer the warranty to the subsequent owner, send or fax a copy of the bill of sale or purchase agreement, new owner's name, address and engine serial number to Mercury Marine's warranty registration department. In the United States mail to:

Mercury Marine  
Attn: Warranty Registration Department  
W6250 W. Pioneer Road  
P.O. Box 1939  
Fond du Lac, WI 54936-1939  
920-929-5054  
Fax 920-929-5893

In Canada mail to:  
Mercury Marine Canada Limited  
2395 Meadowpine Blvd.  
Mississauga, ON  
Canada, L5N 7W6  
Fax 1-800-663-8334

Upon processing the transfer of warranty, Mercury Marine will send registration verification to the new owner of the product by mail.

There is no charge for this service.

For products purchased outside the United States and Canada, contact the distributor in your country, or the distributor closest to you.

## Mercury Product Protection Plan: United States and Canada

(Certain performance products, triple engine installations, and commercial applications are excluded.)

## Section 1 - Warranty

---

The Mercury Product Protection Plan provides coverage against unexpected mechanical and electrical breakdowns that may occur beyond the standard limited warranty.

The optional Mercury Product Protection Plan is the only Factory Plan available for your engine.

One-, two-, three-, four-, or five- year term plans can be purchased up to 12 months after the original engine registration date.

See your participating Mercury MerCruiser dealer for complete program details.

## Mercury MerCruiser Limited Warranty (Gasoline-Fueled Products Only)

### MERCURY MERCUISER LIMITED WARRANTY (GASOLINE-FUELED PRODUCTS ONLY)

#### What is Covered

Mercury Marine warrants its new products to be free of defects in material and workmanship during the period described following.

#### Duration of Coverage

##### Warranty Period for Recreational Use

The warranty period begins on the date the product is first sold to a recreational-use retail purchaser or the date on which the product is first put into service, whichever occurs first. Products installed by an Installation Quality Certified Installer receive one (1) year of additional warranty coverage. The repair or replacement of parts or the performance of service under this warranty does not extend the life of this warranty beyond its original expiration date. The warranty period is specific to the model covered; see your model for the base coverage period:

##### Horizon Sterndrive and Inboard Models, and MX 6.2 Black Scorpion Tow Sport Model Coverage

The Limited Warranty for the Horizon Sterndrive and Inboard Models, and MX 6.2 Black Scorpion Tow Sport Models is four (4) years when installed by an Installation Quality Certified Installer or three (3) years for noncertified installations.

##### SeaCore Sterndrive Model Coverage

The Limited Warranty for SeaCore Sterndrive Models is four (4) years when installed by an Installation Quality Certified Installer or three (3) years for noncertified installations.

##### Standard Model Coverage

The Limited Warranty for Standard Models, which do not include Horizon Sterndrive and Inboard Models, MX 6.2 Black Scorpion Tow Sport Models, or SeaCore Sterndrive Models, is two (2) years when installed by an Installation Quality Certified Installer or one (1) year for noncertified installations.

##### Warranty Period for Commercial Use

The warranty period begins on the date the product is first sold to a commercial-use retail purchaser or the date on which the product is first put into service, whichever occurs first. Commercial users of these products receive warranty coverage for either one (1) year from the date of first retail sale or the accumulation of 500 hours of operation, whichever occurs first. Commercial use is defined as any work-related or employment-related use of the product, or any use of the product that generates income for any part of the warranty period, even if the product is only occasionally used for such purposes. The repair or replacement of parts or the performance of service under this warranty does not extend the life of this warranty beyond its original expiration date.

#### Transfer of Coverage

Unexpired warranty coverage can be transferred from one recreational-use customer to a subsequent recreational-use customer upon proper reregistration of the product. Unexpired warranty coverage cannot be transferred either to or from a commercial-use customer.

#### Termination of Coverage

Warranty coverage is terminated for used product obtained in any of the following ways:

- Repossession from a retail customer
- Purchase at auction
- Purchase from a salvage yard
- Purchase from an insurance company that obtained the product as a result of an insurance claim

**Conditions That Must Be Met in Order to Obtain Warranty Coverage**

Warranty coverage is available only to retail customers that purchase from a dealer authorized by Mercury Marine to distribute the product in the country in which the sale occurred, and then only after the pre-delivery inspection process specified by Mercury Marine is completed and documented. Warranty coverage becomes available upon proper registration of the product by the authorized dealer. Inaccurate warranty registration information regarding recreational use or subsequent change of use from recreational to commercial (unless properly reregistered) may void the warranty at the sole discretion of Mercury Marine. Routine maintenance must be performed according to the maintenance schedule in the Operation, Maintenance & Warranty manual in order to obtain warranty coverage. Mercury Marine reserves the right to make any warranty coverage contingent upon proof of proper maintenance.

**What Mercury Marine Will Do**

Mercury Marine's sole and exclusive obligation under this warranty is limited to, at our option, repairing a defective part, replacing such part or parts with new or Mercury Marine certified remanufactured parts, or refunding the purchase price of the Mercury Marine product. Mercury Marine reserves the right to improve or modify products from time to time without assuming an obligation to modify products previously manufactured.

**How to Obtain Warranty Coverage**

The customer must provide Mercury Marine with a reasonable opportunity to repair and reasonable access to the product for warranty service. Warranty claims shall be made by delivering the product for inspection to a Mercury Marine dealer authorized to service the product. If the purchaser cannot deliver the product to such a dealer, written notice must be given to Mercury Marine. Mercury Marine will then arrange for the inspection and any covered repair. The purchaser in that case shall pay for all related transportation charges and travel time. If the service provided is not covered by this warranty, the purchaser shall pay for all related labor and material and any other expenses associated with that service. The purchaser shall not, unless requested by Mercury Marine, ship the product or parts of the product directly to Mercury Marine. Proof of registered ownership must be presented to the dealer at the time warranty service is requested in order to obtain coverage.

**What Is Not Covered**

This limited warranty does not cover the following:

- Routine maintenance items
- Adjustments
- Normal wear and tear
- Damage caused by abuse
- Abnormal use
- Use of a propeller or gear ratio that does not allow the engine to run in its recommended RPM range (see the Operation, Maintenance & Warranty manual)
- Operation of the product in a manner inconsistent with the recommended operation and duty cycle section of the Operation, Maintenance & Warranty manual
- Neglect
- Accident
- Submersion
- Improper installation (proper installation specifications and techniques are set forth in the installation instructions for the product)
- Improper service
- Use of an accessory or part that was not manufactured or sold by Mercury Marine and that damages the Mercury product
- Jet pump impellers and liners
- Operation with fuels, oils, or lubricants that are not suitable for use with the product (see the Operation, Maintenance & Warranty manual)
- Alteration or removal of parts
- Water entering the engine through the fuel intake, air intake, or exhaust system or damage to the product from insufficient cooling water caused by blockage of the cooling system by a foreign body
- Running the engine out of water
- Mounting the engine too high on the transom
- Operating the boat with the engine over trimmed

## Section 1 - Warranty

Use of the product for racing or other competitive activity, or operating with a racing-type lower unit at any point, even by a previous owner of the product, voids the warranty. Expenses related to haul-out, launch, towing, storage, telephone, rental, inconvenience, slip fees, insurance coverage, loan payments, loss of time, loss of income, or any other type of incidental or consequential damages are not covered by this warranty. Also, expenses associated with the removal or replacement of boat partitions or other material in order to gain access to the product are not covered by this warranty. No individual or entity, including Mercury Marine authorized dealers, has been given authority by Mercury Marine to make any affirmation, representation, or warranty regarding the product, other than those contained in this limited warranty. If such affirmation, representation, or warranty is made, it shall not be enforceable against Mercury Marine.

### DISCLAIMERS AND LIMITATIONS

**THE IMPLIED WARRANTIES OF MERCHANTABILITY AND FITNESS FOR A PARTICULAR PURPOSE ARE EXPRESSLY DISCLAIMED. TO THE EXTENT THAT THEY CANNOT BE DISCLAIMED, THE IMPLIED WARRANTIES ARE LIMITED IN DURATION TO THE LIFE OF THE EXPRESS WARRANTY. INCIDENTAL AND CONSEQUENTIAL DAMAGES ARE EXCLUDED FROM COVERAGE UNDER THIS WARRANTY. SOME STATES/COUNTRIES DO NOT ALLOW FOR THE DISCLAIMERS, LIMITATIONS AND EXCLUSIONS IDENTIFIED ABOVE. AS A RESULT, THEY MAY NOT APPLY TO YOU. THIS WARRANTY GIVES YOU SPECIFIC LEGAL RIGHTS, AND YOU MAY ALSO HAVE OTHER LEGAL RIGHTS WHICH VARY FROM STATE TO STATE AND COUNTRY TO COUNTRY.**

## 3-Year Limited Warranty Against Corrosion

### 3-YEAR LIMITED WARRANTY AGAINST CORROSION

#### What Is Covered

Mercury Marine warrants that each new Mercury, Mariner, Mercury Racing, Sport Jet, M<sup>2</sup> Jet Drive, Tracker by Mercury Marine Outboard, MerCruiser Inboard or Sterndrive engine (Product) will not be rendered inoperative as a direct result of corrosion for the period of time described below.

#### Duration of Coverage

This limited corrosion warranty provides coverage for three (3) years from either the date the product is first sold, or the date on which the product is first put into service, whichever occurs first. The repair and replacement of parts, or the performance of service under this warranty does not extend the life of this warranty beyond its original expiration date. Unexpired warranty coverage can be transferred to subsequent (noncommercial use) purchaser upon proper re-registration of the product. Warranty coverage is terminated for used product repossessed from a retail customer, purchased at auction, from a salvage yard, or from an insurance company that obtained the product as a result of an insurance claim.

#### Condition That Must Be Met in Order to Obtain Warranty Coverage

Warranty coverage is available only to retail customers that purchase from a dealer authorized by Mercury Marine to distribute the product in the country in which the sale occurred, and then only after the Mercury Marine specified pre-delivery inspection process is completed and documented. Warranty coverage becomes available upon proper registration of the product by the authorized dealer. Corrosion prevention devices specified in the Operation, Maintenance & Warranty manual must be in use on the boat, and routine maintenance outlined in the Operation, Maintenance & Warranty manual must be timely performed (including without limitation the replacement of sacrificial anodes, use of specified lubricants, and touch-up of nicks and scratches) in order to maintain warranty coverage. Mercury Marine reserves the right to make warranty coverage contingent upon proof of proper maintenance.

#### What Mercury Will Do

Mercury's sole and exclusive obligation under this warranty is limited to, at our option, repairing a corroded part, replacing such part or parts with new or Mercury Marine certified re-manufactured parts, or refunding the purchase price of the Mercury product. Mercury reserves the right to improve or modify products from time to time without assuming an obligation to modify products previously manufactured.

#### How to Obtain Warranty Coverage

The customer must provide Mercury with a reasonable opportunity to repair, and reasonable access to the product for warranty service. Warranty claims shall be made by delivering the product for inspection to a Mercury dealer authorized to service the product. If purchaser cannot deliver the product to such a dealer, written notice must be given to Mercury. We will then arrange for the inspection and any covered repair. Purchaser in that case shall pay for all related transportation charges and/or travel time. If the service provided is not covered by this warranty, purchaser shall pay for all related labor and material, and any other expenses associated with that service. Purchaser shall not, unless requested by Mercury, ship the product or parts of the product directly to Mercury. Proof of registered ownership must be presented to the dealer at the time warranty service is requested in order to obtain coverage.

#### What Is Not Covered

This limited warranty does not cover electrical system corrosion; corrosion resulting from damage, corrosion which causes purely cosmetic damage, abuse or improper service; corrosion to accessories, instruments, steering systems; corrosion to factory installed jet drive unit; damage due to marine growth; product sold with less than a one year limited Product warranty; replacement parts (parts purchased by the Customer); products used in a commercial application. Commercial use is defined as any work or employment related use of the product, or any use of the product which generates income, for any part of warranty period, even if the product is only occasionally used for such purposes.

## 4-Year Limited Corrosion Warranty: SeaCore Sterndrive Models with Gas Engines

### 4-YEAR LIMITED CORROSION WARRANTY: SEACORE STERNDRIVE MODELS WITH GAS ENGINES

#### What Is Covered

Mercury Marine warrants that each new MerCruiser SeaCore engine, transom, and sterndrive package will not be rendered inoperative as a direct result of corrosion for the period of time described below.

#### Duration of Coverage

This limited corrosion warranty provides coverage for four (4) years from either the date on which the MerCruiser SeaCore engine, transom, and sterndrive package is first sold or the date on which it is first put into service, whichever occurs first. The repair or replacement of parts or the performance of service under this warranty does not extend the life of this warranty beyond its original expiration date. Unexpired warranty coverage can be transferred to a subsequent (noncommercial-use) purchaser upon proper reregistration of the product. Warranty coverage is terminated for used product obtained in any of the following ways:

- Repossession from a retail customer
- Purchase at auction
- Purchase from a salvage yard
- Purchase from an insurance company that obtained the product as a result of an insurance claim

#### Condition That Must Be Met in Order to Obtain Warranty Coverage

Warranty coverage is available only to retail customers that purchase from a dealer authorized by Mercury Marine to distribute the product in the country in which the sale occurred, and then only after the pre-delivery inspection process specified by Mercury Marine is completed and documented. Warranty coverage becomes available upon proper registration of the product by the authorized dealer. Corrosion-prevention devices specified in the Operation, Maintenance & Warranty manual must be in use on the boat, and routine maintenance outlined in the Operation, Maintenance & Warranty manual must be performed according to the maintenance schedule in the Operation, Maintenance & Warranty manual (including without limitation the replacement of sacrificial anodes, use of specified lubricants, and touch-up of nicks and scratches) in order to maintain warranty coverage. Mercury Marine reserves the right to make warranty coverage contingent upon proof of proper maintenance.

#### What Mercury Marine Will Do

Mercury's sole and exclusive obligation under this warranty is limited to, at our option, repairing a corroded part, replacing such part or parts with new or Mercury Marine certified remanufactured parts, or refunding the purchase price of the Mercury product. Mercury reserves the right to improve or modify products from time to time without assuming an obligation to modify products previously manufactured.

#### How to Obtain Warranty Coverage

The customer must provide Mercury Marine with a reasonable opportunity to repair and reasonable access to the product for warranty service. Warranty claims shall be made by delivering the product for inspection to a Mercury Marine dealer authorized to service the product. If the purchaser cannot deliver the product to such a dealer, written notice must be given to Mercury Marine. Mercury Marine will then arrange for the inspection and any covered repair. The purchaser in that case shall pay for all related transportation charges and/or travel time. If the service provided is not covered by this warranty, the purchaser shall pay for all related labor and material, and any other expenses associated with that service. The purchaser shall not, unless requested by Mercury Marine, ship the product or parts of the product directly to Mercury Marine. Proof of registered ownership must be presented to the dealer at the time warranty service is requested in order to obtain coverage.

#### What Is Not Covered

## Section 1 - Warranty

This limited warranty does not cover the following:

- Electrical system corrosion
- Corrosion resulting from damage
- Corrosion that causes purely cosmetic damage
- Abuse or improper service
- Corrosion to accessories, instruments, and steering systems
- Corrosion to a factory-installed jet drive unit
- Damage due to marine growth
- Replacement parts (parts purchased by the customer)
- Product sold with less than a one-year limited product warranty
- Products used in a commercial application. Commercial use is defined as any work or employment related use of the product, or any use of the product which generates income, for any part of warranty period, even if the product is only occasionally used for such purposes.

## Global Warranty Charts

**IMPORTANT:** Please refer to [www.mercurymarine.com/global\\_warranty](http://www.mercurymarine.com/global_warranty) for the most current Global Warranty Charts.

### Consumer Application Warranty Chart

Consumer Application: Standard Factory Limited Warranty by Region & Boat Brand									Limited Corrosion Warranty	
Region	Non-Certified Boat Brand				Certified Boat Brand				All Boat Brands	
	Standard	SeaCore	Horizon	6.2 Scorpion	Standard	SeaCore	Horizon	6.2 Scorpion	Standard and Horizon	SeaCore
<b>USA and Canada</b>	1 year	3 years	3 years	3 years	2 years	4 years	4 years	4 years	3 years	4 years
<b>Latin America</b>	1 year	3 years	1 year	1 year	2 years	4 years	2 years	2 years	3 years	4 years
<b>Mexico</b>	1 year	3 years	1 year	1 year	1 year	4 years	1 year	1 year	1 year	4 years
<b>Europe</b>	2 years	3 years	2 years	2 years	3 years	4 years	3 years	3 years	3 years	4 years
<b>Japan</b>	1 year	1 year	1 year	1 year	1 year	1 year	1 year	1 year	1 year	1 year
<b>Australia and New Zealand</b>	2 years	3 years	3 years	3 years all Tow Sports	2 years	3 years	3 years	3 years all Tow Sports	3 years	4 years
<b>South Pacific</b>	1 year	3 years	1 year	1 year	1 year	3 years	1 year	1 year	3 years	4 years
<b>Asia (excluding Japan, South Pacific, Australia, New Zealand)</b>	2 years	2 years	2 years	3 years all Tow Sports	2 years	2 years	2 years	3 years all Tow Sports	2 years	2 years

**NOTE:** In regions where the Certified Boat Builder program is not applicable, the regular warranty always applies.

**NOTE:** In regions where TBD (To Be Determined) is listed, check with your local dealer for warranty length and conditions.



## Commercial Application Warranty Chart

Commercial Application: Standard Factory Limited Warranty by Region & Boat Brand									Limited Corrosion Warranty	
	Non-Certified Boat Brand				Certified Boat Brand				All Boat Brands	
Region	Standard	SeaCore	Horizon	6.2 Scorpion	Standard	SeaCore	Horizon	6.2 Scorpion	Standard and Horizon	SeaCore
<b>USA and Canada</b>	1 year or 500 hours	1 year or 500 hours	1 year or 500 hours	1 year or 500 hours	1 year or 500 hours	1 year or 500 hours	1 year or 500 hours	1 year or 500 hours	none	none
<b>Latin America</b>	1 year or 500 hours	1 year or 500 hours	1 year or 500 hours	1 year or 500 hours	1 year or 500 hours	1 year or 500 hours	1 year or 500 hours	1 year or 500 hours	none	none
<b>Mexico</b>	1 year	1 year	1 year	1 year	1 year	1 year	1 year	1 year	1 year	1 year
<b>Europe</b>	1 year or 500 hours	1 year or 500 hours	1 year or 500 hours	1 year or 500 hours	1 year or 500 hours	1 year or 500 hours	1 year or 500 hours	1 year or 500 hours	none	none
<b>Japan</b>	1 year or 500 hours	1 year or 500 hours	1 year or 500 hours	1 year or 500 hours	1 year or 500 hours	1 year or 500 hours	1 year or 500 hours	1 year or 500 hours	none	none
<b>Australia and New Zealand</b>	1 year or 500 hours	1 year or 500 hours	1 year or 500 hours	1 year or 500 hours	1 year or 500 hours	1 year or 500 hours	1 year or 500 hours	1 year or 500 hours	none	none
<b>South Pacific</b>	1 year or 500 hours	1 year or 500 hours	1 year or 500 hours	1 year or 500 hours	1 year or 500 hours	1 year or 500 hours	1 year or 500 hours	1 year or 500 hours	none	none
<b>Asia (excluding Japan, South Pacific, Australia, New Zealand)</b>	1 year or 500 hours	1 year or 500 hours	1 year or 500 hours	1 year or 500 hours	1 year or 500 hours	1 year or 500 hours	1 year or 500 hours	1 year or 500 hours	none	none

**NOTE:** In regions where the Certified Boat Builder program is not applicable, the regular warranty always applies

## Government Application Warranty Chart

Government Application: Standard Factory Limited Warranty by Region & Boat Brand									Limited Corrosion Warranty	
	Non-Certified Boat Brand				Certified Boat Brand				All Boat Brands	
Region	Standard	SeaCore	Horizon	6.2 Scorpion	Standard	SeaCore	Horizon	6.2 Scorpion	Standard and Horizon	SeaCore
<b>USA and Canada</b>	1 year	3 years	3 years	3 years	2 years	4 years	4 years	4 years	3 years	4 years
<b>Latin America</b>	1 year or 500 hours	1 year or 500 hours	1 year or 500 hours	1 year or 500 hours	1 year or 500 hours	1 year or 500 hours	1 year or 500 hours	1 year or 500 hours	none	none
<b>Mexico</b>	1 year	1 year	1 year	1 year	1 year	1 year	1 year	1 year	1 year	1 year
<b>Europe</b>	1 year or 500 hours	1 year or 500 hours	1 year or 500 hours	1 year or 500 hours	1 year or 500 hours	1 year or 500 hours	1 year or 500 hours	1 year or 500 hours	none	none
<b>Japan</b>	1 year or 500 hours	1 year or 500 hours	1 year or 500 hours	1 year or 500 hours	1 year or 500 hours	1 year or 500 hours	1 year or 500 hours	1 year or 500 hours	none	none
<b>Australia and New Zealand</b>	1 year or 500 hours	1 year or 500 hours	1 year or 500 hours	1 year or 500 hours	1 year or 500 hours	1 year or 500 hours	1 year or 500 hours	1 year or 500 hours	none	none
<b>South Pacific</b>	1 year or 500 hours	1 year or 500 hours	1 year or 500 hours	1 year or 500 hours	1 year or 500 hours	1 year or 500 hours	1 year or 500 hours	1 year or 500 hours	none	none
<b>Asia (excluding Japan, South Pacific, Australia, New Zealand)</b>	1 year or 500 hours	1 year or 500 hours	1 year or 500 hours	1 year or 500 hours	1 year or 500 hours	1 year or 500 hours	1 year or 500 hours	1 year or 500 hours	none	none

*NOTE: In regions where the Certified Boat Builder program is not applicable, the regular warranty always applies*

## Mercury Installation Quality Certification Program



15502

Mercury MerCruiser products installed by a Mercury Installation Quality Certified Manufacturer are Installation Quality certified products and may receive an additional one (1) year of limited warranty coverage.

The Installation Quality Certification program was developed to recognize MerCruiser boatbuilder customers who have achieved higher manufacturing standards. It is the first and only comprehensive manufacturer-installation certification program in the industry.

The program has three goals:

1. To enhance overall product quality.
2. To improve the boat ownership experience.
3. To enhance overall customer satisfaction.

The certification process is designed to review all facets of manufacturing and engine installation. The program is composed of design, manufacturing and installation review stages with which builders must comply. Certification applies leading-edge methodologies to create:

- Efficiencies and best practices specific to engine installation.
- World-class assembly and component specifications.
- Efficient installation processes.
- Industry standard end-of-line test procedures

Boat builders that successfully complete the program and meet all certification requirements earn Installation Quality System Certified Manufacturer status and receive an additional one (1) year of Mercury limited factory warranty coverage on all MerCruiser-powered boats that are registered on and after the boat builder's certification date for all worldwide registrations.

Mercury has designated a section of our Website to promote the Installation Quality Certification Program and communicate its benefits to consumers. For a current list of MerCruiser-powered boat brands that have earned Installation Quality Certification, visit [www.mercurymarine.com/mercruiser\\_warranty](http://www.mercurymarine.com/mercruiser_warranty).

## California Emissions Limited Warranty

***NOTE:** Mercury Marine does not establish model years for the Mercury MerCruiser product line. In order to comply with CARB warranty regulations, and for that limited purpose only, model year shall have the same meaning as calendar year. As an example, 2003 model year products refers to products manufactured during calendar year 2003.*

The California Air Resources Board has promulgated air emissions regulations for inboard and sterndrive engines. The regulations apply to all inboard and sterndrive engines that were manufactured for the 2003 model year and later. Mercury Marine, in compliance with those regulations, provides this limited warranty for the emission control systems (see the components of the emission control system listed following), and further warrants that the inboard or sterndrive engine was designed, built, and equipped to conform with all applicable regulations adopted by the California Air Resources Board pursuant to its authority in Chapters 1 and 2, Part 5, Division 26 of the Health and Safety Code. For information regarding the limited warranty for the non-emissions related components of the inboard or sterndrive engine, please see the limited warranty statement for your engine.

## What Is Covered

***NOTE:** Mercury Marine does not establish model years for the Mercury MerCruiser product line. In order to comply with CARB warranty regulations, and for that limited purpose only, model year shall have the same meaning as calendar year. As an example, 2003 model year products refers to products manufactured during calendar year 2003.*

**NOTE:** Your dealer will register your engine for warranty coverage for you. The warranty registration process is not related in any way to the process of obtaining a license, title or registration from state boating authorities. You should ask your dealer to update your warranty registration information to reflect a change of address or a transfer of ownership. (This change may be made at any time.) See the Warranty Registration section of your manual or your dealer for more information.

Mercury Marine warrants the components of the emissions control systems (see the components of the emission control system listed following) of its new, 2003 model year and later California certified inboard and sterndrive engines, registered to a California resident, to be free from defects in material or workmanship that cause the failure of a warranted part to be identical in all material respects to that part as described in the application of Mercury Marine for certification from the California Air Resources Board, for the period of time, and under the conditions identified below. The cost to diagnose a warranty failure is covered under the warranty (if the warranty claim is approved). Damage to other engine components caused by the failure of a warranted part will also be repaired under warranty.

## Duration Of Coverage

**NOTE:** Mercury Marine does not establish model years for the Mercury MerCruiser product line. In order to comply with CARB warranty regulations, and for that limited purpose only, model year shall have the same meaning as calendar year. As an example, 2003 model year products refers to products manufactured during calendar year 2003

This limited warranty provides coverage for the components of the emissions control systems of new 2003-2008 model year inboard and sterndrive engines for 2 years from either the date the product is first sold, or first put into service, whichever occurs first. Emission related normal maintenance items such as spark plugs and filters, that are on the warranted parts list (see following) are warranted up to their first required replacement interval only. (See Maintenance Schedule). The repair or replacement of parts, or the performance of service under this warranty, does not extend the life of this warranty beyond its original expiration date. Unexpired warranty coverage can be transferred to a subsequent purchaser. (See instructions on transfer of warranty). Warranty coverage is terminated for used product repossessed from a retail customer, purchased at auction, from a salvage yard, or from an insurance company that obtained the product as a result of an insurance claim.

## How To Obtain Warranty Coverage

The customer must provide Mercury with a reasonable opportunity to repair and reasonable access to the product for warranty service. Warranty claims shall be made by delivering the product for inspection to a Mercury dealer authorized to service the product. If purchaser cannot deliver the product to such a dealer, please notify Mercury Marine and Mercury will then arrange for the inspection and any covered repair. Purchaser in that case shall pay for all related transportation charges and/or travel time. If the service provided is not covered by this warranty, purchaser shall pay for all related labor and material, and any other expenses associated with that service. Purchaser shall not, unless requested by Mercury, ship the product or parts of the product directly to Mercury. Proof of registered ownership must be presented to the dealer at the time warranty service is requested in order to obtain coverage.

## What Mercury Will Do

Mercury Marine's sole and exclusive obligation under this warranty is limited to, at our expense and at our option, repairing or replacing defective parts with new or Mercury Marine certified re-manufactured parts, or refunding the purchase price of the Mercury product. Mercury reserves the right to improve or modify products from time to time without assuming an obligation to modify products previously manufactured.

## What Is Not Covered

This limited warranty does not cover routine maintenance items, tune ups, adjustments, normal wear and tear, damage caused by abuse, abnormal use, use of a propeller or gear ratio that does not allow the engine to run in its recommended wide-open-throttle RPM range (see Specifications), operation of the product in a manner inconsistent with the recommended operation procedures, neglect, accident, submersion, improper installation (proper installation specifications and techniques are set forth in the installation instructions for the product), improper service, use of an accessory or part not manufactured or sold by us, jet pump impellers and liners, operation with fuels, oils or lubricants which are not suitable for use with the product (see Specifications), alteration or removal of parts, or water entering the engine through the fuel intake, air intake or exhaust system. Use of the product for racing or other competitive activity, or operating with a racing type lower unit, at any point, even by a prior owner of the product, voids the warranty.

Expenses related to haul-out, launch, towing, storage, telephone, rental, inconvenience, slip fees, insurance coverage, loan payments, loss of time, loss of income, or any other type of incidental or consequential damages are not covered by this warranty. Also, expenses associated with the removal and/or replacement of boat partitions or material caused by boat design for access to the product are not covered by this warranty.

Non-warranty maintenance, replacement, or repair of emission control devices and systems may be performed by any marine engine repair establishment or individual. The use of non-Mercury parts for non-warranty maintenance or repairs will not be grounds for disallowing other warranty work. The use of add-on (as defined at section 1900 (b)(1) and (b)(10) of Title 13 of the California Code of Regulations) or modified parts not exempted by the California Air Resources Board may be grounds for disallowing a warranty claim, at the discretion of Mercury Marine. Failures of warranted parts caused by the use of a non-exempted add-on or modified part will not be covered.

## Components Of The Emission Control System

1. Fuel Metering System
  - a. Carburetor and internal parts (and/or pressure regulator or fuel injection system)
  - b. Intake valves
2. Air Induction System
  - a. Intake manifold
3. Ignition System
  - a. Spark plugs
  - b. Electronic ignition
  - c. Ignition coil and/or control module
  - d. Ignition wires
4. Positive Crankcase Ventilation (PCV) System
  - a. PCV Valve
  - b. Oil filler cap
5. Exhaust System.

- a. Exhaust manifold
  - b. Exhaust elbow
  - c. Intermediate exhaust elbow
  - d. Lower exhaust pipe
  - e. Tailpipe
  - f. Exhaust valve
6. Miscellaneous Items Used in Above Systems
- a. Hoses, clamps, fittings, tubing, sealing gaskets or devices, and mounting hardware
  - b. Pulleys, belts, and idlers
  - c. Vacuum, temperature, check and time sensitive valves and switches
  - d. Electronic controls.

## Disclaimers And Limitations

**DISCLAIMERS AND LIMITATIONS**  
THE IMPLIED WARRANTIES OF MERCHANTABILITY AND FITNESS FOR A PARTICULAR PURPOSE ARE EXPRESSLY DISCLAIMED. TO THE EXTENT THAT THEY CANNOT BE DISCLAIMED, THE IMPLIED WARRANTIES ARE LIMITED IN DURATION TO THE LIFE OF THE EXPRESS WARRANTY. INCIDENTAL AND CONSEQUENTIAL DAMAGES ARE EXCLUDED FROM COVERAGE UNDER THIS WARRANTY. SOME STATES/COUNTRIES DO NOT ALLOW FOR THE DISCLAIMERS, LIMITATIONS AND EXCLUSIONS IDENTIFIED ABOVE. AS A RESULT, THEY MAY NOT APPLY TO YOU. THIS WARRANTY GIVES YOU SPECIFIC LEGAL RIGHTS, AND YOU MAY ALSO HAVE OTHER LEGAL RIGHTS WHICH VARY FROM STATE TO STATE AND COUNTRY TO COUNTRY.

If you have any questions regarding your warranty rights and responsibilities, refer to Owner Service Assistance for contact information.

## California Emission Control Warranty Statement

### Your Warranty Rights and Obligations

The California Air Resources Board is pleased to explain the emission control system warranty on your 2003 model year<sup>1</sup> and later inboard or sterndrive engine. In California, new inboard and sterndrive engines must be designed, built and equipped to meet the State's stringent anti-smog standards. Mercury Marine must warrant the emission control system on your inboard or sterndrive engine for the periods of time listed below provided there has been no abuse, neglect or improper maintenance of your inboard or sterndrive engine.

Your emission control system may include parts such as the carburetor or fuel injection system, the ignition system, and catalytic converter. Also included may be hoses, belts, connectors and other emission-related assemblies.

Where a warrantable condition exists, Mercury Marine will repair your inboard or sterndrive engine at no cost to you; including diagnosis, parts and labor.

### Manufacturer's Warranty Coverage

For 2003-2008 spark-ignition inboard and sterndrive marine engines: Select emission control parts from model year<sup>1</sup>. 2003-2008 inboard and sterndrive engines are warranted for 2 years. If any emission-related part on your engine is defective under warranty, the part will be repaired or replaced by Mercury Marine.

1. Mercury Marine does not establish model years for the Mercury MerCruiser product line. In order to comply with CARB warranty regulations, and for that limited purpose only, model year shall have the same meaning as calendar year. As an example, 2003 model year products refers to products manufactured during calendar year 2003.

## Owner's Warranty Responsibilities

As the inboard or sterndrive engine owner, you are responsible for the performance of the required maintenance listed in your owner's manual. Mercury Marine recommends that you retain all receipts covering maintenance on your inboard or sterndrive engine, but Mercury Marine cannot deny warranty solely for the lack of receipts or your failure to ensure the performance of all scheduled maintenance.

As the inboard or sterndrive engine owner, you should however be aware that Mercury Marine may deny you warranty coverage if your inboard or sterndrive engine or a part has failed due to abuse, neglect, improper maintenance or unapproved modifications. Warranty coverage is terminated for used product repossessed from a retail customer, purchased at auction, from a salvage yard, or from an insurance company that obtained the product as a result of an insurance claim.

You are responsible for presenting your inboard or sterndrive engine to a Mercury Marine dealer authorized to service the product as soon as a problem exists. The warranty repairs will be completed in a reasonable amount of time, not to exceed 30 days.

If you have any questions regarding your warranty rights and responsibilities, refer to Owner Service Assistance for contact information.

## Emission Control Information Label

A tamper-resistant Emission Control Information label is affixed in a visible location to the engine at time of manufacture by Mercury MerCruiser. In addition to the required emissions statement, the label lists the engine serial number, family, FEL (emission level), date of manufacture (month, year), and the engine displacement. Please note that the low emissions certification will not affect the fit, function, or performance of the engines. Boatbuilders and dealers may not remove the label or the part it is affixed to before sale. If modifications are necessary, contact Mercury MerCruiser about the availability of replacement decals before proceeding.

		<b>EMISSION CONTROL INFORMATION</b>	
THIS ENGINE CONFORMS TO 2003 CALIFORNIA EMISSION REGULATIONS FOR SPARK IGNITION MARINE ENGINES			
REFER TO OWNER'S MANUAL FOR MAINTENANCE SPECIFICATIONS AND ADJUSTMENTS			
SERIAL#	OMXXXXXXXX	D.O.M	JAN. 2003
FAMILY	XXXXX XXXXXX	DISP	X.XL
FEL.	XX.X g/kW-hr		

11018

### Emission Control Label - Non CE Marked

"SERIAL#" - Engine Serial Number

"FAMILY" - Engine Family

"FEL." - Family Emission Limit

"D.O.M." - Date of Manufacture

"DISP" - Piston Displacement

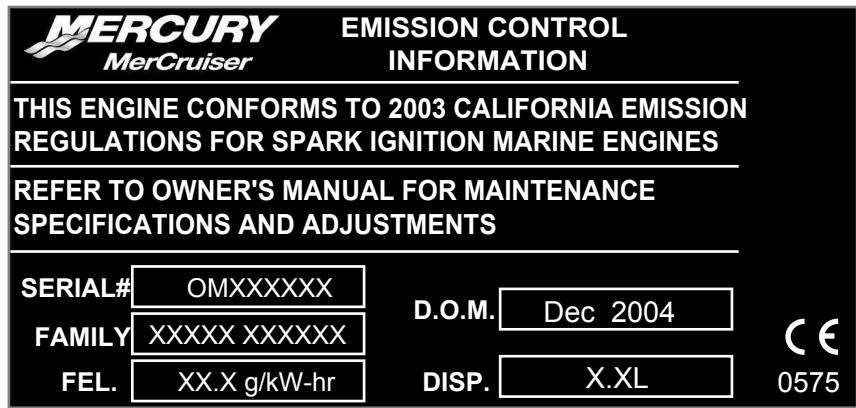

10652

### Emission Control Label - CE Marked

"SERIAL#" - Engine Serial Number

"FAMILY" - Engine Family

"FEL." - Family Emission Limit

"D.O.M." - Date of Manufacture

"DISP" - Piston Displacement

CE - When this mark is present in the lower right corner of the Emission Control Information Label, on the engine, the Declaration of Conformance applies. Refer to the front page of this Manual for further information.

## Owner Responsibility

The owner/operator is required to have routine engine maintenance performed to maintain emission levels within prescribed certification standards.

The owner/operator is not to modify the engine in any manner that would alter the horsepower or allow emissions levels to exceed their predetermined factory specifications.

## Emission Certification Star Label

Your boat is labeled on the hull with one of the following star labels. The Symbol for Cleaner Marine Engines Means:

1. Cleaner Air and Water - for a healthier lifestyle and environment.
2. Better Fuel Economy - burns up to 30-40 percent less gas and oil than conventional carbureted two-stroke engines, saving money and resources.
3. Longer Emission Warranty - Protects consumer for worry free operation.





Beginning January 1, 2003, one Three-Star label will be included with each factory-certified Mercury MerCruiser engine.

All Mercury MerCruiser engines (500 hp and below) will have a Three-Star Ultra Low Emission rating. The Three-Star label identifies that these engines meet the California Air Resources Board's Sterndrive and Inboard marine engine 2003 exhaust emission standards. Engines meeting these standards have 65% lower emissions than One-Star - Low Emissions engines.

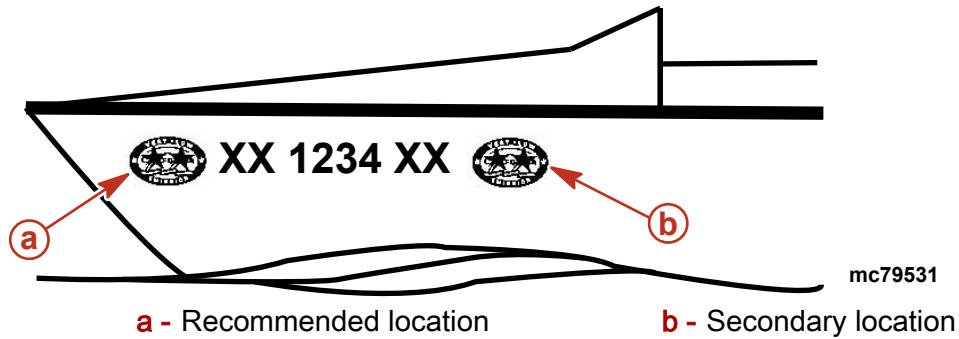

The Three-Star label will be affixed on the left side of the hull as shown.



<b>One Star - Low emission</b>	
 <p style="text-align: right;">mc79569-1</p>	<p>The one-star label identifies personal watercraft, outboard, sterndrive and inboard engines that meet the Air Resources Board's Personal Watercraft and Outboard marine engine 2001 exhaust emission standards. Engines meeting these standards have 75% lower emissions than conventional carbureted two-stroke engines. These engines are equivalent to the U.S. EPA's 2006 standards for marine engines.</p>
<b>Two Stars - Very Low emission</b>	
 <p style="text-align: right;">mc79570-1</p>	<p>The two-star label identifies personal watercraft, outboard, sterndrive and inboard engines that meet the Air Resources Board's Personal Watercraft and Outboard marine engine 2004 exhaust emission standards. Engines meeting these standards have 20% lower emissions than One Star - Low-Emission engines.</p>
<b>Three Stars - Ultra Low emission</b>	
 <p style="text-align: right;">mc79571-1</p>	<p>The three-star label identifies engines that meet the Air Resources Board's Personal Watercraft and Outboard marine engine 2008 exhaust emission standards or the Sterndrive and Inboard marine engine 2003 exhaust emission standards. Engines meeting these standards have 65% lower emissions than One Star - Low Emission engines.</p>
<b>Four Stars - Super Ultra Low emission</b>	
 <p style="text-align: right;">mc79572-1</p>	<p>The Four Star label identifies engines that meet the Air Resources Board's Sterndrive and Inboard marine engine 2009 exhaust emission standards. Personal Watercraft and Outboard marine engines may also comply with these standards. Engines meeting these standards have 90% lower emissions than One Star - Low Emission engines.</p>

Notes:

# Section 2 - Getting to Know Your Power Package

## Table of Contents

---

Lanyard Stop Switch.....	20	Console Mount Features .....	24
Instrumentation.....	21	Zero Effort Features.....	24
System View .....	21	Electrical System Overload Protection.....	25
Digital Gauges .....	22	Audio Warning System.....	26
Analog Gauges .....	22	Testing The Audio Warning System .....	27
Remote Controls.....	22	Engine Guardian Strategy.....	27
Panel Mount Features .....	23	Warning Horn Signals.....	27

---



## Lanyard Stop Switch

The purpose of a lanyard stop switch is to turn off the engine when the operator moves outside the operator's position (as in accidental ejection from the operator's position).

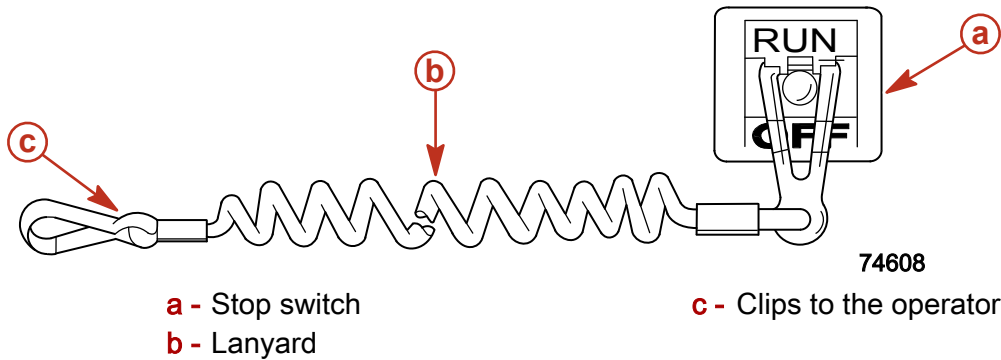

Accidental ejections, such as falling overboard, are more likely to occur in:

- low sided sport boats
- bass boats
- high performance boats

Accidental ejections can also occur from:

- poor operating practices
- sitting on the seat or gunwale at planing speeds
- standing at planing speeds
- operating at planing speeds in shallow or obstacle infested waters
- releasing your grip on the steering wheel that is pulling in one direction
- consuming alcohol or drugs
- high speed boating maneuvers

The lanyard is a cord usually between 122 and 152 cm (4 and 5 feet) in length when stretched out, with an element on one end made to be inserted into the switch and a snap on the other end for attaching to the operator. The lanyard is coiled to make its at-rest condition as short as possible to minimize the likelihood of lanyard entanglement with nearby objects. Its stretched-out length is made to minimize the likelihood of accidental activation should the operator choose to move around in an area close to the normal operator's position. If it is desired to have a shorter lanyard, wrap the lanyard around the operator's wrist or leg, or tie a knot in the lanyard.

Activation of the lanyard stop switch will stop the engine immediately, but the boat will continue to coast for some distance depending upon the velocity and degree of any turn at shut down. However, the boat will not complete a full circle. While the boat is coasting, it can cause injury to anyone in the boat's path as seriously as the boat would when under power.

We strongly recommend that other occupants be instructed on proper starting and operating procedures should they be required to operate the engine in an emergency (e.g. if the operator is accidentally ejected).

### **⚠ WARNING**

**Should the operator fall out of the boat, the possibility of serious injury or death from being run over by the boat can be greatly reduced by stopping the engine immediately. Always properly connect both ends of the stop switch lanyard to the stop switch and the operator.**

Accidental or unintended activation of the switch during normal operation is also a possibility. This could cause any, or all, of the following potentially hazardous situations:

- Occupants could be thrown forward due to unexpected loss of forward motion, a particular concern for passengers in the front of the boat who could be ejected over the bow and possibly struck by the propulsion or steering components.
- Loss of power and directional control in heavy seas, strong current or high winds.
- Loss of control when docking.

### ⚠ WARNING

Avoid serious injury or death from deceleration forces resulting from accidental or unintended stop switch activation. The boat operator should never leave the operator's station without first disconnecting the stop switch lanyard from the operator.

## Instrumentation

### System View

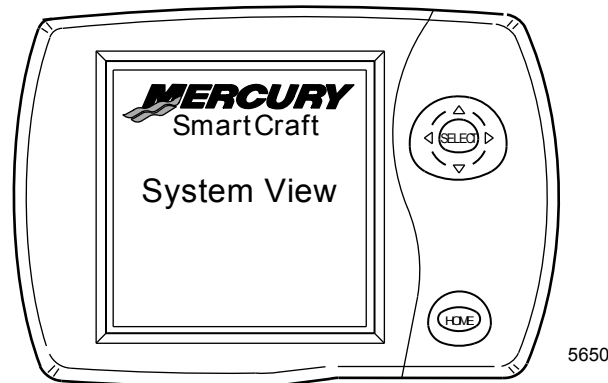

Your power package may be connected to the Mercury SC5000 SmartCraft System View display. The display monitors and reports information ranging from basic operating data to engine alarm data.

The SC5000 System View Display is a comprehensive boat information center. System View allows the boat operator to receive a wealth of critical operational information, displayed clearly and instantly at the helm on the LCD display. The System View continuously monitors and reports information ranging from basic operating data to detailed vessel environment information. System View displays water temperature and depth, engine trim status, boat speed, steering angle, system preventive maintenance reminders and systems diagnostics. System View also can be fully integrated with the boat's GPS, if equipped, to provide up to the minute location, course, speed, and fuel-to-destination information.

When a problem is detected with the engine or system, the System View will alert the operator to the potential problem by displaying the alarm message in the information window, located at the bottom of the view screen.

If the problem can cause immediate engine damage, the Engine Guardian System will respond to the problem by limiting engine power. Immediately reduce throttle speed to idle. Refer to the System View Operation Manual for further explanation of the problem and the correct action to take.

## Digital Gauges

A Mercury SmartCraft System instrument package can be purchased for this product. A few of the functions the instrument package will display are engine RPM, coolant temperature, oil pressure, battery voltage, fuel consumption and engine operating hours.

The SmartCraft Instrument package will also aid in Engine Guardian diagnostics. The SmartCraft Instrument package will display critical engine alarm data and potential problems.

Refer to the manual with your gauge package for the warning functions monitored and basic operation of the SmartCraft Instrument package.

## Analog Gauges

The following is a brief explanation of the instrumentation typically found on some boats. The owner/operator should be familiar with all instruments and their functions. Because of the large variety of instrumentation and manufacturers, you should have your boat dealer explain the particular gauges and normal readings for your boat.

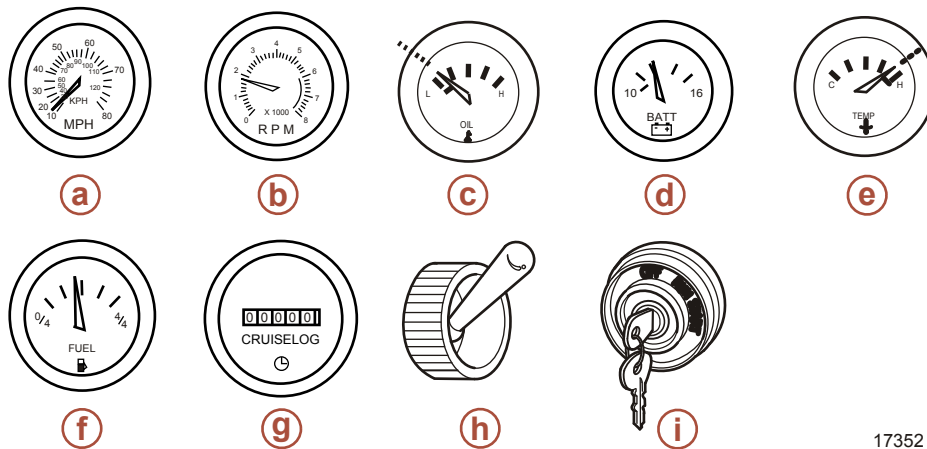

17352

- a - Speedometer
- b - Tachometer
- c - Oil pressure gauge
- d - Voltmeter
- e - Water temperature gauge
- f - Fuel gauge
- g - Hour meter
- h - Bilge blower switch
- i - Ignition switch

**Speedometer:** Indicates boat speed.

**Tachometer:** Indicates engine RPM.

**Oil Pressure Gauge:** Indicates engine oil pressure.

**Voltmeter:** Indicates battery voltage.

**Water Temperature Gauge:** Indicates engine operating temperature.

**Fuel Gauge:** Indicates quantity of fuel in tank.

**Hour meter:** Records engine operating time.

**Bilge Blower Switch:** Operates bilge blower.

**Ignition Switch:** Allows operator to start and stop engine.

## Remote Controls

Your boat may be equipped with a Mercury Precision Parts or Quicksilver remote controls. All controls may not have all features shown. Consult your dealer for a description and/or demonstration of your remote control.

## PANEL MOUNT FEATURES

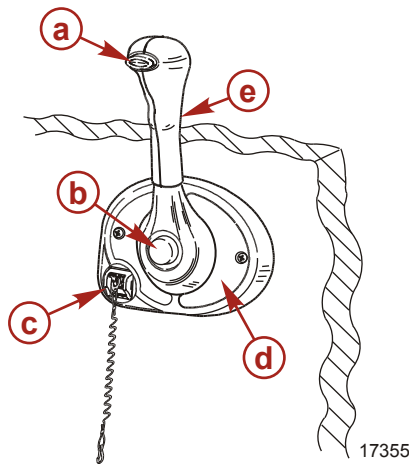

- |                                 |  |
|---------------------------------|--|
| <b>a</b> - Neutral lock button  | <b>d</b> - Control handle tension adjustment screw |
| <b>b</b> - Throttle only button | <b>e</b> - Control handle                          |
| <b>c</b> - Lanyard stop switch  |  |

**Neutral Lock Button** - Prevents accidental shift and throttle engagement. Neutral lock button must be pushed in to move the control handle out of neutral.

**Throttle Only Button** - Allows engine throttle advancement without shifting the engine. This is done by disengaging the shift mechanism from the control handle. The throttle only button can be depressed only when the remote control handle is in the neutral position, and should only be used to assist in starting the engine.

**Lanyard Stop Switch** - Turns the ignition off whenever the operator (when attached to the lanyard) moves far enough away from the operator's position to activate the switch. Refer to **Lanyard Stop Switch** for information on the use of this switch.

**Control Handle** - Operation of the shift and throttle are controlled by the movement of the control handle. Push the control handle forward from neutral with a quick firm motion to the first detent for forward gear. Continue pushing forward to increase speed. Pull the control handle back from neutral with a quick firm motion to the first detent for reverse gear and continue pushing back to increase speed.

**Control Handle Tension Adjustment Screw - (not visible)** This screw is used to adjust the effort required to move the remote control handle. Refer to instructions provided with remote control for complete adjustment instructions.

## CONSOLE MOUNT FEATURES

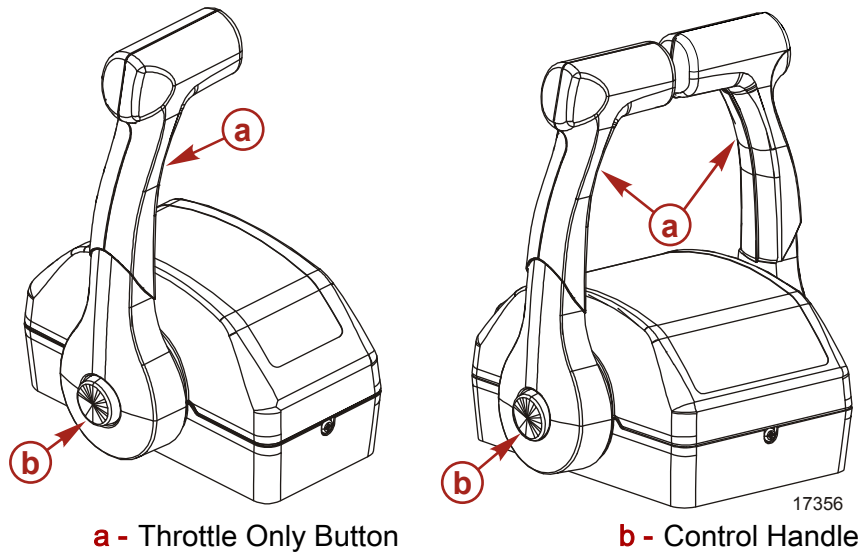

**Throttle Only Button** - Allows engine throttle advancement without shifting the engine. This is done by disengaging the shift mechanism from the control handle. The throttle only button can be depressed only when the remote control handle is in the neutral position.

**Control Handles** - Operation of the the shift and throttle are controlled by the movement of the control handle. Push the control handle forward from neutral with a quick firm motion to the first detent for forward gear and continue pushing forward to increase speed. Pull the control handle back from neutral with a quick firm motion to the first detent for reverse gear and continue pushing back to increase speed.

**Control Handle Tension Adjustment Screw - (not visible)** This screw is used to adjust the effort required to move the remote control handle. Refer to instructions provided with remote control for complete adjustment instructions.

## Zero Effort Features

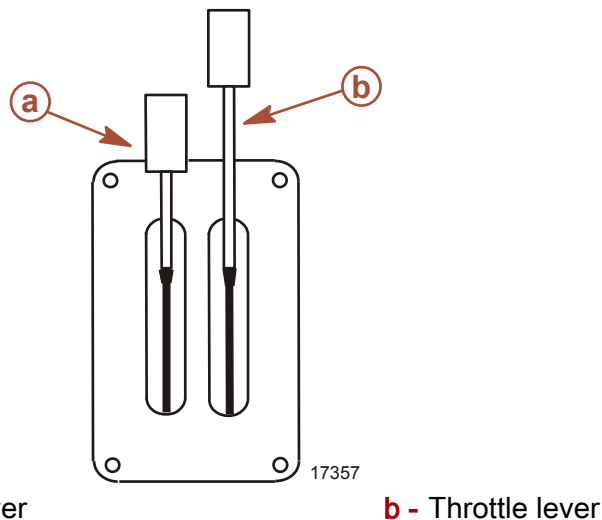

**Shift Lever** - Shift functions are controlled by the movement of the shift lever. Shift into reverse by moving the shift lever to its aft position. Shift into neutral by moving the shift lever to its center position. Shift into forward by moving the shift lever to its forward position.



**Throttle Lever** - Throttle functions are controlled by the movement of the throttle lever. Increase the RPM by moving the throttle lever forward. Achieve Wide Open Throttle (WOT) by placing the throttle lever in its full forward position. Decrease RPM by moving the throttle lever back. Achieve minimum RPM (idle) by placing the throttle lever in its full aft position.

## Electrical System Overload Protection

If an electrical overload occurs, a fuse will blow or the circuit breaker will trip open. Find and correct the cause before replacing the fuse or resetting the circuit breaker.

**NOTE:** In an emergency, when the engine must be operated and the cause for the high-current draw cannot be located and corrected, turn off or disconnect all accessories connected to the engine and instrumentation wiring. Reset the circuit breaker. If the breaker remains open, the electrical overload has not been eliminated. Further checks must be made on the electrical system. Contact your authorized dealer.

1. A circuit breaker protects the engine wiring harness and the instrumentation power lead. Test the circuit breaker by pushing the red button. If the circuit breaker is functioning properly, the yellow lever will appear. Reset after testing, or if tripped, by pushing the yellow lever back into the housing.

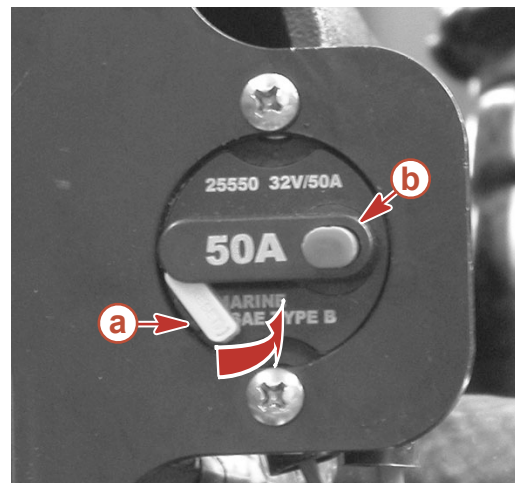

22529

**Yellow lever style circuit breaker-typical**

**a** - Yellow lever-shown tripped

**b** - Red test button

2. A 90 amp fuse is located on the large post of the starter solenoid. This fuse protects the engine wiring harness if an electrical overload occurs.

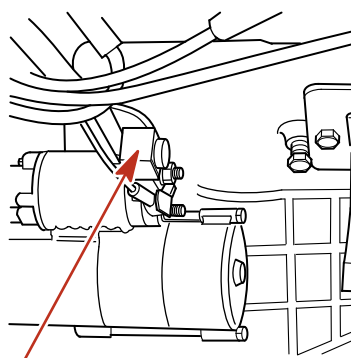

mc74907-1

3. Four fuses are located on the port side of the engine. These fuses protect the main power, fuel pump, ignition, and accessory circuits.

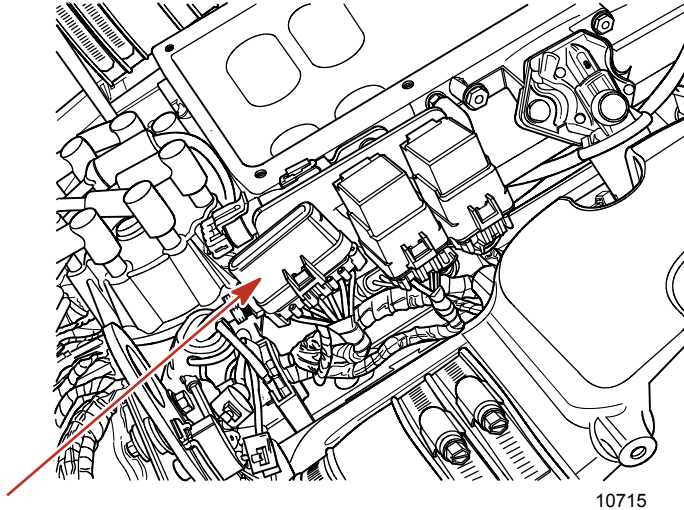

10715

4. A 20 amp fuse may be located in the ignition switch "I" terminal lead to protect the electrical system. Check for blown fuse if the ignition key is turned to the "START" position and nothing happens (and circuit breaker is not tripped).

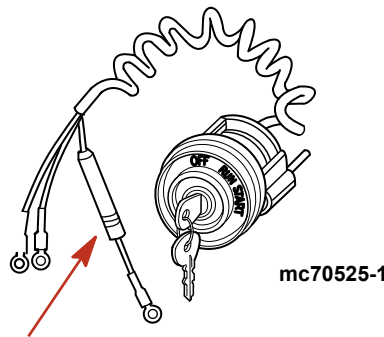

mc70525-1

## Audio Warning System

Your Mercury MerCruiser power package may be equipped with an Audio Warning System. The Audio Warning System will not protect the engine from damage. It is designed to warn the operator that a problem has occurred.

The audio warning system will sound with a continuous horn if one of the following occurs:

- Engine oil pressure too low
- Engine temperature too hot
- Seawater pressure too low

The audio warning system will sound with an intermittent beeping if the following occurs:

- Transmission fluid temperature too hot
- Transmission pressure too low

### **NOTICE**

A continuous horn indicates a critical fault. Operating the engine during a critical fault can damage components. If the warning horn emits a continuous beep, do not operate the engine unless avoiding a hazardous situation.

If the alarm sounds, stop the engine immediately. Investigate cause and correct it, if possible. If the cause cannot be determined, contact your authorized Mercury MerCruiser dealer.

## Testing The Audio Warning System

1. Turn the ignition switch to the "ON" position without cranking the engine.
2. Listen for the audio alarm. The alarm will sound if the system is functioning correctly.

## Engine Guardian Strategy

**IMPORTANT: Boat speed could be reduced to idle and may not respond to the throttle.**

Engine Guardian Strategy is designed to help reduce the potential for engine damage by reducing engine power when a potential problem is sensed by the ECM. Engine Guardian monitors:

- Oil pressure
- Coolant temperature
- Seawater pressure
- Engine overspeed
- Exhaust Manifold Temperature [8.1 liter (496 cid) engines only]

Also the Engine Guardian Strategy will reduce engine power to 90 percent of maximum if any sensor on the power package fails.

For example, if the water inlet becomes partially blocked, Engine Guardian Strategy will reduce the available power level of the engine to help prevent damage from decreased water flow to the engine. If the debris passes through and full water flow is restored, engine power levels are restored to normal.

To avoid a possible recurrence of the problem you should contact an authorized dealer. The ECM stores the fault and with this information the technician will be able to more rapidly diagnose problems.

## Warning Horn Signals

Most faults will cause the warning horn circuit to activate. How the warning horn activates depends on how serious the problem is. There are four warning horn states:

- Caution - horn signal varies with product line and calibration. Minimal guardian.
- Warning - horn signal varies with product line and calibration.
- Severe - horn is beeping constantly.
- Critical - horn is beeping constantly and guardian will be at forced idle.

In addition, depending on the gauge package, there will be warning icons and fault messages on the dash mounted gauges.

Notes:

# Section 3 - On The Water

## Table of Contents

Safe Boating Suggestions.....	30	Passenger Safety In Pontoon Boats And Deck Boats.....	35
Be Alert To Carbon Monoxide Poisoning.....	31	Boats Having An Open Front Deck .....	35
Good Ventilation .....	32	Boats With Front-Mounted, Raised Pedestal Fishing Seats .....	36
Poor Ventilation .....	32	Wave And Wake Jumping.....	36
Basic Boat Operation.....	32	Impact With Underwater Hazards.....	37
Launching and Boat Operation.....	32	Conditions Affecting Operation.....	37
Operation Chart .....	32	Weight Distribution (Passengers and Gear)	
Starting and Stopping the Scorpion Engine .....	33	Inside the Boat.....	37
Starting the Engine .....	33	Bottom Of Boat.....	38
Stopping the Engine .....	34	Cavitation.....	38
Throttle Only Operation.....	34	Ventilation.....	38
Freezing Temperature Operation.....	34	Elevation And Climate.....	38
Drain Plug and Bilge Pump.....	34	Propeller Selection.....	39
Protecting People In The Water.....	34	Getting Started.....	39
While You Are Cruising .....	34	20-Hour Break-In Period.....	39
While Boat Is Stationary .....	35	After Break-In Period.....	39
High-Speed And High-Performance Boat Operation .....	35	End of First Season Checkup.....	40



## Safe Boating Suggestions

In order to safely enjoy the waterways, familiarize yourself with local and all other governmental boating regulations and restrictions, and consider the following suggestions.

### **Know and obey all nautical rules and laws of the waterways.**

- Mercury MerCruiser strongly recommends that all powerboat operators complete a boating safety course. Courses are offered in the U.S.A. by: The U.S. Coast Guard Auxiliary, The Power Squadron, The Red Cross and your state or provincial boating law enforcement agency. Inquiries may be made to the Boating Hotline at 1-800-368-5647 or the Boat U.S. Foundation at 1-800-336-BOAT.

### **Perform safety checks and required maintenance.**

- Follow a regular schedule and ensure that all repairs are properly made.

### **Check safety equipment on board.**

- Here are some suggestions of the types of safety equipment to carry when boating:
  - Approved fire extinguishers
  - Signal devices: flashlight, rockets or flares, flag and whistle or horn
  - Tools necessary for minor repairs
  - Anchor and extra anchor line
  - Manual bilge pump and extra drain plugs
  - Drinking water
  - Transistor radio
  - Paddle or oar
  - Spare propeller, thrust hubs, and an appropriate wrench
  - First aid kit and instructions
  - Water-proof storage containers
  - Spare operating equipment, batteries, bulbs and fuses
  - Compass and map or chart of the area
  - Personal flotation device (1 per person on board)

### **Watch for signs of weather change and avoid foul weather and rough-sea boating.**

### **Tell someone where you are going and when you expect to return.**

### **Passenger boarding.**

- Stop the engine whenever passengers are boarding, unloading or are near the back (stern) of the boat. Shifting the drive unit into neutral is not sufficient.

### **Use personal flotation devices.**

- Federal Law requires that there be a U. S. Coast Guard approved life jacket (personal flotation device), correctly sized and readily accessible for every person on board, plus a throwable cushion or ring. We strongly advise that everyone wear a life jacket at all times while in the boat.

### **Prepare other boat operators.**

- Instruct at least 1 person on board in the basics of starting and operating the engine and boat handling in case the driver becomes disabled or falls overboard.

### **Do not overload your boat.**

- Most boats are rated and certified for maximum load (weight) capacities (refer to your boat capacity plate). Know your boat's operating and loading limitations. Know if your boat will float if full of water. When in doubt, contact your authorized Mercury MerCruiser dealer or the boat manufacturer.

**Ensure that everyone in the boat is properly seated.**

- Do not allow anyone to sit or ride on any part of the boat that was not intended for such use. This includes the backs of seats, gunwales, transom, bow, decks, raised fishing seats and any rotating fishing seat; anywhere that sudden unexpected acceleration, sudden stopping, unexpected loss of boat control or sudden boat movement could cause a person to be thrown overboard or into the boat. Ensure that all passengers have a proper seat and are in it before any boat movement.

**Never be under the influence of alcohol or drugs while boating (it is the law).**

- They impair your judgment and greatly reduce your ability to react quickly.

**Know your boating area and avoid hazardous locations.****Be alert.**

- The operator of the boat is responsible by law to maintain a proper lookout by sight and hearing. The operator must have an unobstructed view particularly to the front. No passengers, load or fishing seats should block the operators view when the boat is above idle or planing transition speed. Watch out for others, the water and your wake.

**Never drive your boat directly behind a water skier in case the skier falls.**

- As an example, your boat traveling at 40 km/h (25 MPH) will overtake a fallen skier who was 61 m (200 ft.) in front of you in 5 seconds.

**Watch fallen skiers.**

- When using your boat for water skiing or similar activities, always keep a fallen or down skier on the operator's side of the boat while returning to attend to the skier. The operator should always have the down skier in sight and never back up to the skier or anyone in the water.

**Report accidents.**

- Boat operators are required by law to file a Boating Accident Report with their state boating law enforcement agency when their boat is involved in certain boating accidents. A boating accident must be reported if 1) there is loss of life or probable loss of life, 2) there is personal injury requiring medical treatment beyond first aid, 3) there is damage to boats or other property where the damage value exceeds \$500.00 or 4) there is complete loss of the boat. Seek further assistance from local law enforcement.

## Be Alert To Carbon Monoxide Poisoning

Carbon monoxide is present in the exhaust fumes of all internal combustion engines including the outboards, sterndrives and inboard engines that propel boats, as well as the generators that power various boat accessories. Carbon monoxide is a deadly gas that is odorless, colorless and tasteless.

Early symptoms of carbon monoxide poisoning, which should not be confused with seasickness or intoxication, include headache, dizziness, drowsiness and nausea.

**⚠ WARNING**

**Avoid prolonged exposure to carbon monoxide. Carbon monoxide poisoning can lead to unconsciousness, brain damage or death. Ensure that the boat, while at rest or underway, is well ventilated.**

## Good Ventilation

Ventilate the passenger area, open the side curtains or forward hatches to remove fumes.

1. Example of desired air flow through the boat.



mc79553-1

## Poor Ventilation

Under certain conditions, permanently enclosed or canvas enclosed cabins or cockpits with insufficient ventilation may draw in carbon monoxide. Install one or more carbon monoxide detectors in your boat.

Although the occurrence is rare, on a very calm day, swimmers and passengers in an open area of a stationary boat that contains or is near an operating engine may be exposed to a hazardous level of carbon monoxide.

1. Examples of poor ventilation while a boat is stationary:

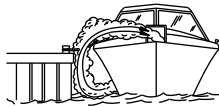

**a**

**a** - Operating the engine when the boat is moored in a confined space



**b**

**b** - Mooring close to another boat with its engine operating

mc79554-1

2. Examples of poor ventilation while a boat is moving:



**a**

**a** - Operating the boat with the trim angle of the bow too high



**b**

**b** - Operating the boat with no forward hatches open (station wagon effect)

mc79556-1

## Basic Boat Operation

### Launching and Boat Operation

**IMPORTANT:** Install bilge drain plug prior to launching boat.

#### OPERATION CHART

Operation Chart			
BEFORE STARTING	AFTER STARTING	WHILE UNDERWAY	AFTER STOPPING
Install bilge drain plug.	Observe all gauges to check condition of engine. If not normal, stop engine.	Observe all gauges to check condition of engine. If not normal, stop engine.	Turn ignition key to the "OFF" position.
Open engine hatch.	Check for fuel, oil, water, fluid and exhaust leaks.	Listen for the audio alarm.	Turn battery switch to the "OFF" position.
Turn battery switch on.	Check shift and throttle control operation.		Close fuel shut off valve.



Operation Chart			
BEFORE STARTING	AFTER STARTING	WHILE UNDERWAY	AFTER STOPPING
Operate bilge blowers.	Check steering operation.		Close seacock, if equipped.
Open fuel shut off valve.			Flush cooling system if in saltwater.
Open seacock, if equipped.			Drain bilge.
Close the drain system.			
Check the engine oil.			
Perform all other checks specified by your dealer and/or boat builder.			
Listen for Audio Warning Alarm to sound when the ignition switch is in the "ON" position.			

## Starting and Stopping the Scorpion Engine

*NOTE: Only perform those functions applicable to your power package.*

### STARTING THE ENGINE

1. Check all items listed in the Operation Chart.
2. Place the remote control handle in neutral.

#### ⚠ CAUTION

**Overheating from insufficient cooling water will cause engine and drive system damage. Ensure that there is sufficient water always available at water inlet holes during operation.**

#### ⚠ WARNING

**Avoid fire or explosion. Before starting the engine, operate the bilge blower for at least five minutes to remove any explosive fumes from the engine compartment. If the boat is not equipped with a bilge blower, open the engine hatch and leave it open while starting the engine.**

3. Turn ignition key to "START". Release key when engine starts and allow switch to return to "ON" position. Allow engine to warm up (6-10 minutes on first start of the day). The engine will typically idle at 900-1000 RPM until warm, and then return to the normal idle RPM of approximately 650 RPM.

*NOTE: If the engine has not run for a long period of time it may require a couple of attempts.*

4. If engine does not start after 3 attempts:
  - a. Push the **throttle only** button and position the remote control handle/throttle lever to the 1/4 throttle position.
  - b. Turn ignition key to "START". Release key when engine starts and allow switch to return to "ON" position.
5. If engine does not start after step 4:
  - a. Move the remote control handle/throttle lever to full throttle position, then return to 1/4 throttle.
  - b. Turn ignition key to "START". Release key when engine starts and allow switch to return to "ON" position.

6. Inspect the power package for fuel, oil, water and exhaust leaks.
7. Move control handle with a firm, quick motion forward to shift to forward gear, or backward to shift to reverse. After shifting, advance throttle to desired setting.

**⚠ CAUTION**

**Shifting the drive system at RPMs greater than engine idle speed may cause internal damage to the drive system. Shift the drive system only when the engine is at idle RPM.**

### STOPPING THE ENGINE

1. Move the remote control handle to neutral/idle and allow the engine to slow to idle speed. If engine has been operated at high speed for a long period of time, allow the engine to cool at idle speed for 3 to 5 minutes.
2. Turn ignition key to the "OFF" position.

### Throttle Only Operation

1. Refer to **Remote Controls** section for remote control features.
2. Move the control lever to the idle/neutral position.
3. Depress and hold the throttle only button, and move the control lever to the idle/forward or idle/reverse position.
4. Advancing the control lever beyond the idle/forward or idle/reverse position will cause engine speed to increase.

**IMPORTANT: Moving the control lever back to the idle/neutral position will disengage the throttle only button and allow the engine to shift into gear.**

5. Throttle only mode is deactivated by moving the control lever to the idle/neutral position. Moving the control lever from the idle/neutral position to the idle/forward or idle/reverse position without pressing the throttle only button will shift the unit into the chosen gear.

### Freezing Temperature Operation

**IMPORTANT: If the boat is operated during periods of freezing temperature, precautions must be taken to prevent freeze damage to the power package. Damage caused by freezing is not covered by Mercury MerCruiser Limited Warranty.**

### Drain Plug and Bilge Pump

The engine compartment in your boat is a natural place for water to collect. For this reason, boats are normally equipped with a drain plug and/or a bilge pump. It is very important to check these items on a regular basis to ensure that the water level does not come into contact with your power package. Components on your engine will be damaged if submerged. Damage caused by submersion is not covered by the Mercury MerCruiser Limited Warranty.

## Protecting People In The Water

### While You Are Cruising

It is very difficult for a person in the water to take quick action to avoid a boat heading in their direction, even at slow speeds.



21604

Always slow down and exercise extreme caution any time you are boating in an area where there might be people in the water.

Whenever a boat is moving (even coasting) and the gear shift is in neutral, there is sufficient force by the water on the propeller to cause the propeller to rotate. This neutral propeller rotation can cause serious injury.

## While Boat Is Stationary

### ⚠ WARNING

Stop your engine immediately whenever anyone in the water is near your boat. Serious injury to the person in the water is likely if contacted by a rotating propeller, a moving boat, a moving gearcase, or any solid device rigidly attached to a moving boat or gearcase.

Shift into neutral and shut off the engine before allowing people to swim or be in the water near your boat.

## High-Speed And High-Performance Boat Operation

If your boat is considered a high-speed or high-performance boat with which you are unfamiliar, we recommend that you never operate it at its high speed capability without first requesting an initial orientation and demonstration ride with your dealer or an operator experienced with your boat. For additional information, refer to **Hi-Performance Boat Operation** booklet (90-849250-R2) from your dealer, distributor or Mercury Marine.

## Passenger Safety In Pontoon Boats And Deck Boats

Whenever the boat is in motion, observe the location of all passengers. Do not allow any passengers to stand or use seats other than those designated for traveling faster than idle speed. A sudden reduction in boat speed, such as plunging into a large wave or wake, a sudden throttle reduction, or a sharp change of boat direction, could throw them over the front of boat. Falling over the front of the boat between the two pontoons will position them to be run over.

### Boats Having An Open Front Deck

No one should ever be on the deck in front of the fence while the boat is in motion. Keep all passengers behind the front fence or enclosure.

Persons on the front deck could easily be thrown overboard or persons dangling their feet over the front edge could get their legs caught by a wave and pulled into the water.

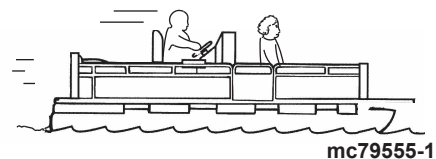
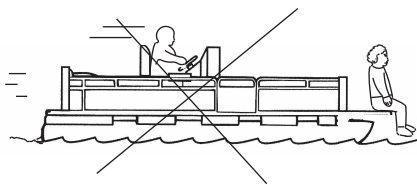

### ⚠ WARNING

Avoid serious injury or death from falling over the front end of a pontoon or deck boat and being run over. Stay back from the front end of the deck and remain seated while the boat is in motion.

## Boats With Front-Mounted, Raised Pedestal Fishing Seats

Elevated fishing seats are not intended for use when the boat is traveling faster than idle or trolling speed. Sit only in seats designated for traveling at faster speeds.

Any unexpected, sudden reduction in boat speed could result in the elevated passenger falling over the front of the boat.

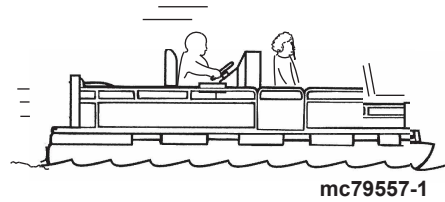
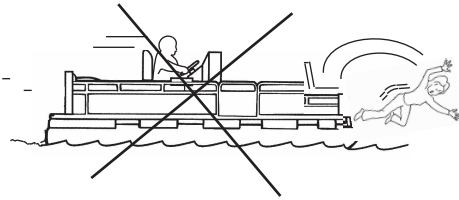

## Wave And Wake Jumping

### **⚠ WARNING**

**Avoid serious injury or death from being thrown within or out of a boat when it lands after jumping a wave or wake. Avoid wave or wake jumping whenever possible. Instruct all occupants that if a wake or wave jump occurs, get low and hang on to any boat hand hold.**

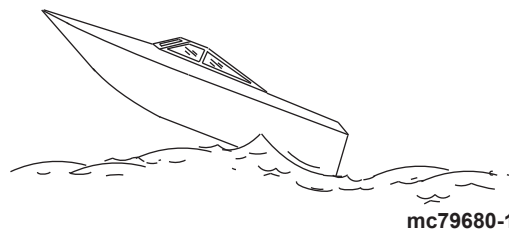

Operating recreational boats over waves and wakes is a natural part of boating. However, when this activity is done with enough speed to force the boat hull partially or completely out of the water, certain hazards arise, particularly when the boat re-enters the water.

The primary concern is the boat changing direction while in the midst of the jump. In such cases the landing may cause the boat to violently veer in a new direction. Such a sharp change in direction or turn can cause occupants to be thrown out of their seats or out of the boat.

There is another less common hazardous result from allowing your boat to launch off of a wave or wake. If the bow of your boat pitches down far enough while airborne, upon water contact it may penetrate under the water surface and submarine for an instant. This will bring the boat nearly to a stop in an instant and can send the occupants flying forward. The boat may also veer sharply to one side.

## Impact With Underwater Hazards

Reduce speed and proceed with caution whenever you're driving a boat in shallow water or in areas where the waters are suspected of having underwater obstacles that could be struck by the underwater drive components, rudder or the boat bottom.

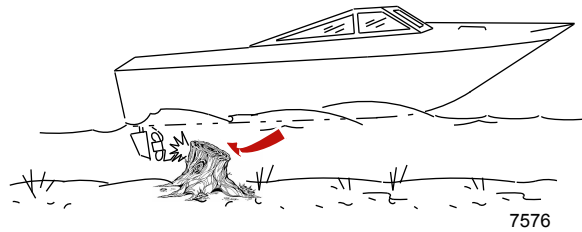

**IMPORTANT:** The most important thing you can do to help reduce injury or impact damage from striking a floating or underwater object is control the boat speed. Under these conditions, boat speed should be kept to a maximum speed of 24 to 40 km/h (15 to 25 MPH).

Striking a floating/underwater object may result in an infinite number of situations. Some of these situations could result in the following:

- The boat could move suddenly in a new direction. Such a sharp change in direction or turn can cause occupants to be thrown out of their seats or out of the boat.
- A rapid reduction in speed. This will cause occupants to be thrown forward, even out of the boat.
- Impact damage to the underwater drive components, rudder and/or boat.

Keep in mind, one of the most important things you can do to help reduce injury or impact damage in these situations is control the boat speed. Boat speed should be kept to a minimum planing speed when driving in waters known to have underwater obstacles.

After striking a submerged object, stop the engine as soon as possible and inspect the drive system for any broken or loose parts. If damage is present or suspected, the power package should be taken to an authorized Mercury MerCruiser dealer for a thorough inspection and necessary repair.

The boat should be checked for hull fractures, transom fractures and water leaks.

Operating with damaged underwater drive components, rudder or boat bottom could cause additional damage to other parts of the power package, or could affect control of the boat. If continued operation is necessary, do so at greatly reduced speeds.

### **⚠ WARNING**

Avoid serious injury or death from loss of boat control. Continued boating with major impact damage can result in sudden component failure with or without subsequent impacts. Have the power package thoroughly inspected and any necessary repairs made.

## Conditions Affecting Operation

### Weight Distribution (Passengers and Gear) Inside the Boat

#### Shifting weight to rear (stern):

- Generally increases speed and engine RPM
- Causes bow to bounce in choppy water
- Increases danger of following wave splashing into the boat when coming off plane

- At extremes, can cause the boat to porpoise

**Shifting weight to front (bow):**

- Improves ease of planing
- Improves rough water ride
- At extremes, can cause the boat to veer back and forth (bow steer)

## Bottom Of Boat

To maintain maximum speed, the boat bottom should be:

- Clean, free of barnacles and marine growth
- Free of distortion; nearly flat where it contacts the water
- Straight and smooth, fore and aft

Marine vegetation may accumulate when the boat is docked. This growth must be removed before operation; it may clog the water inlets and cause the engine to overheat.

## Cavitation

Cavitation occurs when water flow cannot follow the contour of a fast-moving underwater object, such as a gear housing or a propeller. Cavitation permits the propeller to speed up, but the boat speed to reduce. Cavitation can seriously erode the surface of the gear housing or the propeller. Common causes of cavitation are:

- Weeds or other debris snagged on the propeller
- Bent propeller blade
- Raised burrs or sharp edges on the propeller

## Ventilation

Ventilation is caused by surface air or exhaust gases that are introduced around the propeller resulting in propeller speed-up and a reduction in boat speed. Air bubbles strike the propeller blade and cause erosion of the blade surface. If allowed to continue, eventual blade failure (breakage) will occur. Excessive ventilation is usually caused by:

- Drive unit trimmed out too far.
- A missing propeller diffuser ring.
- A damaged propeller or gear housing, which allows exhaust gases to escape between propeller and gear housing.
- Drive unit installed too high on transom.

## Elevation And Climate

Elevation and climate changes will affect the performance of your power package. Loss of performance can be caused by:

- Higher elevations
- Higher temperatures
- Low barometric pressures
- High humidity

For you to have optimum engine performance under changing weather conditions, it is essential that the engine be propped to allow the engine to operate at or near the top end of the specified maximum RPM range with a normal boat load during your normal boating weather conditions.

In most cases, recommended RPM can be achieved by changing to a lower pitch propeller.

## Propeller Selection

**IMPORTANT:** The engines covered in this manual are equipped with an RPM rev-limiter that is set to an upper (or limited) RPM amount. This limit is slightly above the normal operating range of the engine and is designed to help prevent damage from excessive engine RPM. Once the RPM returns to the recommended operating RPM range, normal engine operation resumes.

It is the responsibility of the boat manufacturer and/or the selling dealer to equip the power package with the correct propeller. Refer to Mercury Marine's web page [http://www.mercurymarine.com/everything\\_you\\_need\\_to\\_know\\_about\\_propellers6](http://www.mercurymarine.com/everything_you_need_to_know_about_propellers6).

Select a propeller that will allow the engine power package to operate at or near the top end of the recommended WOT operating RPM range with a normal load.

If full throttle operation is below the recommended range, the propeller must be changed to prevent loss of performance and possible engine damage. On the other hand, operating an engine above the recommended operating RPM range will cause higher than normal wear and/or damage.

After initial propeller selection, the following common problems may require that the propeller be changed to a lower pitch.

- Warmer weather and greater humidity cause a loss of RPM.
- Operating in a higher elevation causes a loss of RPM.
- Operating with a dirty boat bottom causes a loss of RPM.
- Operating with increased load (additional passengers, pulling skiers) causes a loss of RPM.

For better acceleration, such as is needed for water skiing, use the next lower pitch propeller. When not pulling skiers, do not operate at full throttle when using the lower pitch propeller.

## Getting Started

### 20-Hour Break-In Period

**IMPORTANT:** The first 20 hours of operation is the engine break-in period. Correct break-in is essential to obtain minimum oil consumption and maximum engine performance. During this break-in period, the following rules must be observed:

- Do not operate below 1500 RPM for extended periods of time for the first 10 hours. Shift into gear as soon as possible after starting and advance the throttle above 1500 rpm **if conditions permit safe operation.**
- Do not operate at one speed consistently for extended periods.
- Do not exceed 3/4 throttle during the first 10 hours. During the next 10 hours, occasional operation at full throttle is permissible (5 minutes at a time maximum).
- Avoid full throttle acceleration from idle speed.
- Do not operate at full throttle until the engine reaches normal operating temperature.
- Frequently check engine oil level. Add oil as needed. It is normal for oil consumption to be high during the break-in period.

### After Break-In Period

To help extend the life of your Mercury MerCruiser power package, the following recommendations should be considered;

- Ensure that propeller allows the engine to operate at or near the top of the specified WOT RPM range (Refer to **Specifications** and **Maintenance**) when at full throttle with a normal boat load.
- Operation at 3/4 throttle setting or lower is recommended. Refrain from prolonged operation at WOT RPM.
- Change the engine oil and oil filter. Refer to **Maintenance**.
- Change the transmission oil and filter. Refer to **Maintenance** (ZF Transmission models).<sup>1</sup>

### End of First Season Checkup

At the end of the first season of operation, contact an authorized Mercury MerCruiser dealer to discuss and/or perform scheduled maintenance items. If you are in an area where the product is operated continuously, year-round, you should contact your dealer at the end of the first 100 hours of operation or once yearly, whichever occurs first.

1. Require fluid and filter change after the first 25 hours and then every 100 hours.



# Section 4 - Specifications

## Table of Contents

---

Fuel Requirements.....	42	Engine Oil.....	43
Fuel Ratings .....	42	Engine Specifications: Scorpion.....	44
Using Reformulated (Oxygenated) Gasolines		Fluid Specifications.....	44
(USA Only) .....	42	Engine .....	44
Gasolines Containing Alcohol .....	42	Transmission .....	45

---

## Fuel Requirements

**IMPORTANT: Use of improper gasoline can damage your engine. Engine damage resulting from the use of improper gasoline is considered misuse of the engine, and damage caused thereby will not be covered under the limited warranty.**

### Fuel Ratings

Mercury MerCruiser engines will operate satisfactorily when using a major brand of unleaded gasoline meeting the following specifications:

**USA and Canada** - having a posted pump Octane Rating of 87 (R+M)/2 minimum. Premium gasoline [92 (R+M)/2 Octane] is also acceptable. Do not use leaded gasoline.

**Outside USA and Canada** - having a posted pump Octane Rating of 90 RON minimum. Premium gasoline (98 RON) is also acceptable. If unleaded gasoline is not available, use a major brand of leaded gasoline.

### Using Reformulated (Oxygenated) Gasolines (USA Only)

This type of gasoline is required in certain areas of the USA. The 2 types of oxygenates used in these fuels is Alcohol (Ethanol) or Ether (MTBE or ETBE). If Ethanol is the oxygenate that is used in the gasoline in your area, refer to Gasolines Containing Alcohol.

These Reformulated Gasolines are acceptable for use in your Mercury MerCruiser engine.

### Gasolines Containing Alcohol

If the gasoline in your area contains either methanol (methyl alcohol) or ethanol (ethyl alcohol), you should be aware of certain adverse effects that can occur. These adverse effects are more severe with methanol. Increasing the percentage of alcohol in the fuel can also worsen these adverse effects.

Some of these adverse effects are caused because the alcohol in the gasoline can absorb moisture from the air, resulting in a separation of the water/alcohol from the gasoline in the fuel tank.

The fuel system components on your Mercury MerCruiser engine will withstand up to 10% alcohol content in the gasoline. We do not know what percentage your boat's fuel system will withstand. Contact your boat manufacturer for specific recommendations on the boat's fuel system components (fuel tanks, fuel lines, and fittings). Be aware that gasolines containing alcohol may cause increased:

- Corrosion of metal parts
- Deterioration of rubber or plastic parts
- Fuel permeation through rubber fuel lines
- Starting and operating difficulties

#### WARNING

**FIRE AND EXPLOSION HAZARD: Fuel leakage from any part of the fuel system can be a fire and explosion hazard which can cause serious bodily injury or death. Careful periodic inspection of entire fuel system is mandatory, particularly after storage. All fuel components should be inspected for leakage, softening, hardening, swelling or corrosion. Any sign of leakage or deterioration requires replacement before further engine operation.**

Because of possible adverse effects of alcohol in gasoline, it is recommended that only alcohol-free gasoline be used where possible. If only fuel containing alcohol is available, or if the presence of alcohol is unknown, increased inspection frequency for leaks and abnormalities is required.

**IMPORTANT:** When operating a Mercury MerCruiser engine on gasoline containing alcohol, storage of gasoline in the fuel tank for long periods should be avoided. Long periods of storage, common to boats, create unique problems. In cars alcohol-blend fuels normally are consumed before they can absorb enough moisture to cause trouble, but boats often sit idle long enough for phase separation to take place. In addition, internal corrosion may take place during storage if alcohol has washed protective oil films from internal components.

## Engine Oil

To help obtain optimum engine performance and to provide maximum protection, we strongly recommend the use of the following oils listed in the order of recommendation:

1. MerCruiser / Quicksilver Synthetic Blend, NMMA FC-W rated, 4-cycle oil.
2. MerCruiser / Quicksilver 25W40 NMMA FC-W rated oil.
3. A NMMA FC-W rated oil.
4. MerCruiser / Quicksilver 4-cycle 25W40, non FC-W rated oil.
5. A good grade straight weight detergent automotive oil per the operating chart below.

**NOTE:** The use of non-detergent oils, multi-viscosity oils (other than as specified), non FC-W rated synthetic oils, low quality oils or oils that contain solid additives are specifically not recommended.

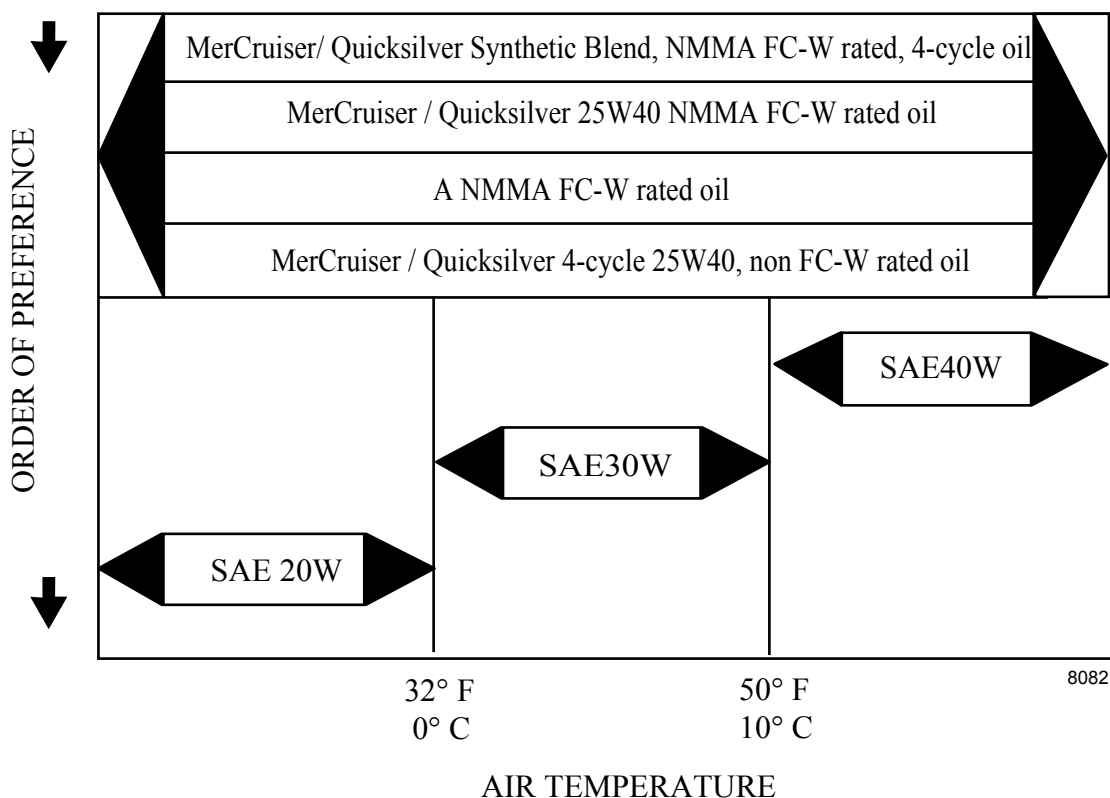

# Engine Specifications: Scorpion

## Tow Sports Models

Models	Black Scorpion	MX 6.2 Black Scorpion
Horsepower	330	340
Kilowatts	246	254
Displacement	5.7 L (350cid)	6.2 L (377cid)
Specified WOT RPM Range	4800–5200	
Idle RPM in Neutral	650	
Minimum Oil Pressure @ Idle	41 kPa (6 psi)	
Thermostat	71° C (160° F)	
Timing @ Idle	Not adjustable	
Firing Order	1-8-4-3-6-5-7-2	
Electrical System	12-Volt negative (-) ground	
Alternator Rating	65 amp	
Recommended Battery Rating (Minimum)	750 CCA, 950 MCA, or 180 Ah	
Spark Plug Type	AC Platinum (AC 41-993)	
Spark Plug Gap	1.5 mm (0.060 in.)	

The horsepower and kilowatt performance data were obtained and corrected in accordance with SAE J1228/ISO 8665 Crankshaft Power.

All measurements were obtained using an accurate service tachometer with the engine at normal operating temperatures.

The oil pressure must be checked with the engine at normal operating temperature.

The idle speed on EFI models is not adjustable.

## Fluid Specifications

### Engine

**IMPORTANT: All capacities are approximate fluid measures.**

**IMPORTANT: It may be necessary to adjust oil levels depending on installation angle and cooling systems (heat exchanger and fluid lines).**

All Models	Capacity	Fluid Type
Engine Oil (With Filter) <sup>1</sup>	4.25 liters (4.5 U.S. qts)	Quicksilver Synthetic Blend, NMMA FC-W rated, 4 cycle oil
Seawater Cooling System <sup>2</sup>	20 liters (21 U.S. qts)	Propylene Glycol and Purified Water

1. Always use the dipstick to determine the exact quantity of oil or fluid required.

2. Seawater Cooling System capacity information is for winterization use only.

## Transmission

Model	Capacity	Fluid Type
71C In-Line	1.66 Liter (1.75 U.S. Quart)	Dexron III Automatic Transmission Fluid
45C In-Line <sup>3</sup> .	1.94 Liter (66 oz.)	Dexron III Automatic Transmission Fluid
RV-36 V-drive (gear box only) <sup>4</sup> .	0.5 Liter (0.75 U.S. Quart)	SAE 30 Heavy Duty Motor Exxon Spartan, EP-68 Gear Oil, APG-80 Gear Oil

3. Refer to manufacturers owners manual for information concerning remote V-drive fluid capacities.

4. Walters V-drive Applications have 2 fluid service points, the transmission and the gear box.

## Notes:

# Section 5 - Maintenance

## Table of Contents

Owner/Operator Responsibilities.....	48	Changing Filter .....	55
Dealer Responsibilities.....	48	Transmission Fluid.....	56
Maintenance.....	48	Checking While the Engine is Warm .....	56
Do It Yourself Maintenance Suggestions.....	49	Checking While Engine is Cold .....	56
Inspection.....	49	Changing .....	56
Maintenance Schedule - Inboard Models.....	50	IAC Muffler.....	56
Routine Maintenance .....	50	Changing .....	56
Each Day Start .....	50	Cleaning The Flame Arrestor.....	56
Each Day End .....	50	Positive Crankcase Ventilation Valve (PCV)	
Weekly .....	50	.....	57
Every Two Months or 50 Hours .....	50	Changing .....	57
Scheduled Maintenance .....	50	Changing Water Separating Fuel Filter.....	58
After the Initial 20 Hour Break-in .....	50	In-line Fuel Filter.....	59
Every 100 Hours or Annually (Whichever		Lubrication.....	61
Occurs First) .....	50	Throttle Cable.....	61
Every 300 Hours or 3 Years .....	50	Transmission Linkage.....	61
Every 5 Years .....	51	Serpentine Drive Belt.....	63
Maintenance Log.....	51	Checking .....	63
Engine Oil.....	51	Replacing Belt and/or Adjusting Tension .....	63
Checking .....	52	Flushing The Power Package—Tow Sports.....	64
Filling .....	52	The Boat Out of the Water .....	64
Changing Oil and Filter .....	53	The Boat In the Water .....	66
Easy Engine Oil Drain System .....	54	Battery.....	68
Engine Oil Drain Pump .....	54	Multiple EFI Engine Battery Precautions.....	69

## Owner/Operator Responsibilities

It is the operator's responsibility to perform all safety checks, to ensure that all lubrication and maintenance instructions are complied with for safe operation and to return the unit to an authorized Mercury MerCruiser dealer for a periodic checkup.

Normal maintenance service and replacement parts are the responsibility of the owner/operator and as such, are not considered defects in workmanship or material within the terms of the warranty. Individual operating habits and usage contribute to the need for maintenance service.

Proper maintenance and care of your power package will ensure optimum performance and dependability and will keep your overall operating expenses at a minimum. See your authorized Mercury MerCruiser dealer for service aids.

## Dealer Responsibilities

In general, a dealer's responsibilities to the customer include predelivery inspection and preparation such as:

- Ensure that the boat is properly equipped.
- Prior to delivery, make certain that the Mercury MerCruiser power package and other equipment are in proper operating condition.
- Make all necessary adjustments for maximum efficiency.
- Familiarize the customer with the on-board equipment.
- Explain and demonstrate the operation of the power package and boat.
- Provide you with a copy of a Predelivery Inspection Checklist.
- Your selling dealer should fill out the Warranty Registration Card completely and mail it to the factory immediately upon sale of the new product.

## Maintenance

### ⚠ WARNING

Avoid product damage, injury, or death from electrical shock, fire or explosion. Always disconnect both battery cables from the battery before servicing the power package.

### ⚠ WARNING

Fuel vapors can be present in the engine compartment. Avoid injury or power package damage caused by fuel vapors or explosion. Always ventilate the engine compartment prior to servicing the power package.

**IMPORTANT:** Refer to the maintenance schedule for complete listing of all scheduled maintenance to be performed. Some listings can be done by owner/operator, while others should be performed by an authorized Mercury MerCruiser dealer. Before attempting maintenance or repair procedures not covered in this manual, it is recommended that a Mercury MerCruiser Service Manual be purchased and read thoroughly.

*NOTE: Maintenance points are color coded for ease of identification. See the decal on engine for identification.*

Maintenance Point Color Codes	
Blue	Coolant
Yellow	Engine Oil



Maintenance Point Color Codes	
Orange	Fuel
Black	Gear Lube Oil (Sterndrive models only)
Brown	Transmission (Inboard models only)

## Do It Yourself Maintenance Suggestions

Present day marine equipment, such as your Mercury MerCruiser power package, are highly technical pieces of machinery. Electronic ignition and special fuel delivery systems provide greater fuel economies, but also are more complex for the untrained mechanic.

If you are one of those persons who likes to do it yourself, here are some suggestions for you.

- Do not attempt any repairs unless you are aware of the Cautions, Warnings and procedures required. Your safety is our concern.
- If you attempt to service the product yourself, we suggest you order the service manual for that model. The service manual outlines the correct procedures to follow. It is written for the trained mechanic, so there may be procedures you don't understand. Do not attempt repairs if you do not understand the procedures.
- There are special tools and equipment that are required to perform some repairs. Do not attempt these repairs unless you have these special tools and/or equipment. You can cause damage to the product in excess of the cost a dealer would charge you.
- Also, if you partially disassemble an engine or drive assembly and are unable to repair it, the dealer's mechanic must reassemble the components and test to determine the problem. This will cost you more than taking it to the dealer immediately upon having a problem. It may be a very simple adjustment to correct the problem.
- Do not telephone the dealer, service office or the factory to attempt for them to diagnose a problem or to request the repair procedure. It is difficult for them to diagnose a problem over the telephone.

Your authorized dealer is there to service your power package. They have qualified factory trained mechanics.

It is recommended you have the dealer do periodic maintenance checks on your power package. Have them winterize it in the fall and service it before the boating season. This will reduce the possibility of any problems occurring during your boating season when you want trouble free boating pleasure.

## Inspection

Inspect your power package often, and at regular intervals, to help maintain its top operating performance and correct potential problems before they occur. The entire power package should be checked carefully, including all accessible engine parts.

- Check for loose, damaged or missing parts, hoses and clamps; tighten or replace as necessary.
- Check plug leads and electrical leads for damage.
- Remove and inspect the propeller. If badly nicked, bent or cracked, contact your authorized Mercury MerCruiser dealer.
- Repair nicks and corrosion damage on power package exterior finish. Contact your authorized Mercury MerCruiser dealer.

## Maintenance Schedule - Inboard Models

### Routine Maintenance

*NOTE: Only perform maintenance which applies to your particular power package.*

#### EACH DAY START

- Check the crankcase oil (interval can be extended based on experience).
- Check the transmission fluid level.

#### EACH DAY END

- If operating in salt, brackish or polluted waters, flush the cooling system after each use.

#### WEEKLY

- Check the water inlets for debris or marine growth. Check the seawater strainer and clean.
- Check the coolant level.
- Check the transmission fluid.

#### EVERY TWO MONTHS OR 50 HOURS

- Operating in saltwater or brackish or polluted water only: treat the power package with Corrosion Guard.
- Check the battery connections and the fluid level.
- Ensure that the gauges and the wiring connections are secure. Clean the gauges.<sup>1</sup>

### Scheduled Maintenance

*NOTE: Only perform maintenance which applies to your particular power package.*

#### AFTER THE INITIAL 20 HOUR BREAK-IN

To help extend the life of your Mercury MerCruiser power package, the following is recommended:

1. Change the engine oil and filter
2. Change the transmission fluid and filter on inboard models.

*NOTE: ZF Marine requires the transmission fluid and filter be changed to preserve the warranty.*

#### EVERY 100 HOURS OR ANNUALLY (WHICHEVER OCCURS FIRST)

- Touch-up the paint on the power package.
- Change the crankcase oil and filter.
- Change the transmission fluid (ZF Transmission Models)<sup>2</sup>.
- Replace the water separating fuel filter element.
- Check the steering system and the remote control for loose, missing or damaged parts. Lubricate the cables and the linkages.
- Clean the flame arrestor, IAC muffler (MPI engines)<sup>3</sup>, and the crankcase ventilation hoses. Inspect the PCV valve, if equipped.

#### EVERY 300 HOURS OR 3 YEARS

- Inspect the condition of the belts.
- Check the engine mount for tightness and retorque if necessary.
- Check the distributor cap, if equipped.

1. If operating in saltwater, interval is reduced to every 25 hours or 30 days whichever occurs first.

2. Require fluid and filter change after the first 25 hours and then every 100 hours.

3. Contact your authorized Mercury MerCruiser dealer to replace the IAC muffler.



## Checking

1. Stop the engine. Allow approximately 5 minutes for the oil to drain into the oil pan. The boat must be at rest in the water.
2. Remove the dipstick. Wipe clean and reinstall fully into the dipstick tube. Wait 60 seconds to allow trapped air to vent.

**NOTE:** Ensure that dipstick is installed with oil level indication marks facing the rear of the engine (flywheel end).

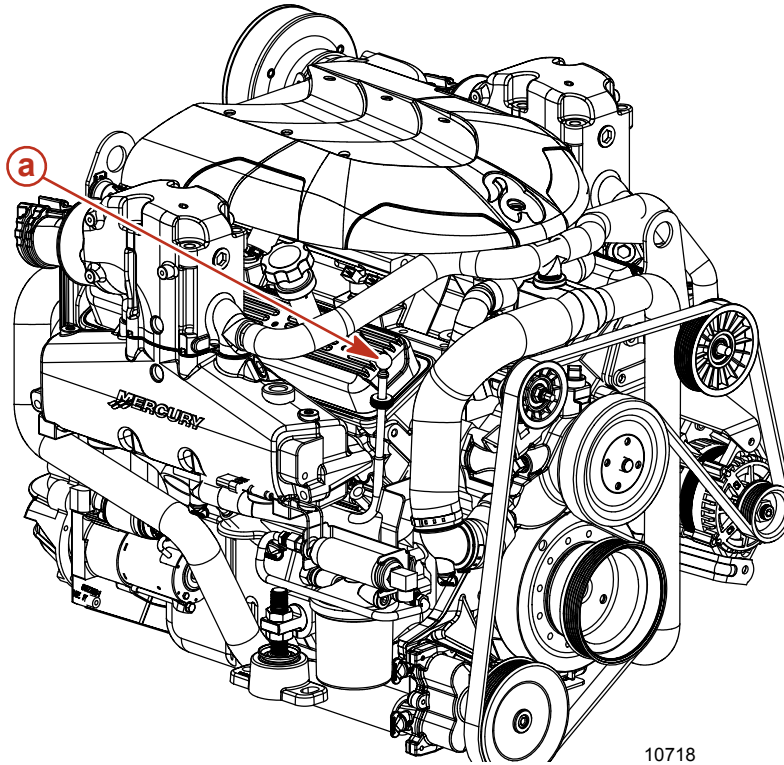

10718

**a** - Dipstick tube

**IMPORTANT:** Add the specified engine oil to bring the level up to, but not over, the full or OK range mark on the dipstick.

3. Remove the dipstick and observe the oil level. Oil level must be between full or OK range and add. Reinstall dipstick into dipstick tube.

## Filling

**IMPORTANT:** Do not overfill the engine with oil.

**IMPORTANT:** Always use the dipstick to determine the exact quantity of oil or fluid required.

1. Remove oil fill cap.

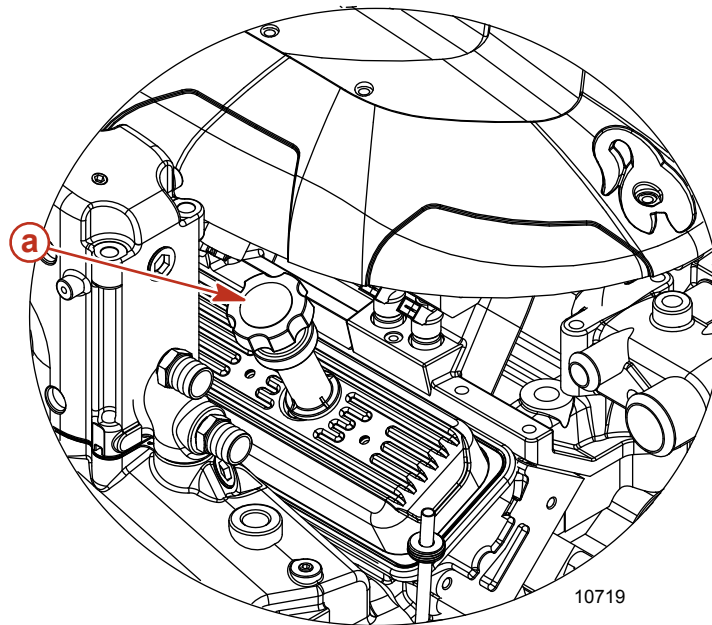

**a** - Oil fill cap

**IMPORTANT:** Add the specified engine oil to bring the level up to, but not over, the full or OK range mark on the dipstick.

2. Add the specified engine oil to bring the level up to, but not over, the full or OK range mark on the dipstick. Recheck oil level.
3. Replace the fill cap.

Models	Capacity	Fluid Type
Engine Oil (With Filter)	4.25 liters (4.5 U.S. Quart)	Mercury/Quicksilver Synthetic Blend MerCruiser Engine Oil 25W-40

## Changing Oil and Filter

Refer to the Maintenance schedule for the change interval. Engine oil should be changed before placing the boat in storage.

**IMPORTANT:** Change engine oil when the engine is warm from operation. Warm oil flows more freely, carrying away more impurities. Use only recommended engine oil (refer to Specifications).

## EASY ENGINE OIL DRAIN SYSTEM

**NOTE:** Boat must be out of water to perform this procedure.

1. Loosen the oil filter to vent the system.
2. Remove the bilge drain plug.
3. Pull tether through the bilge drain.

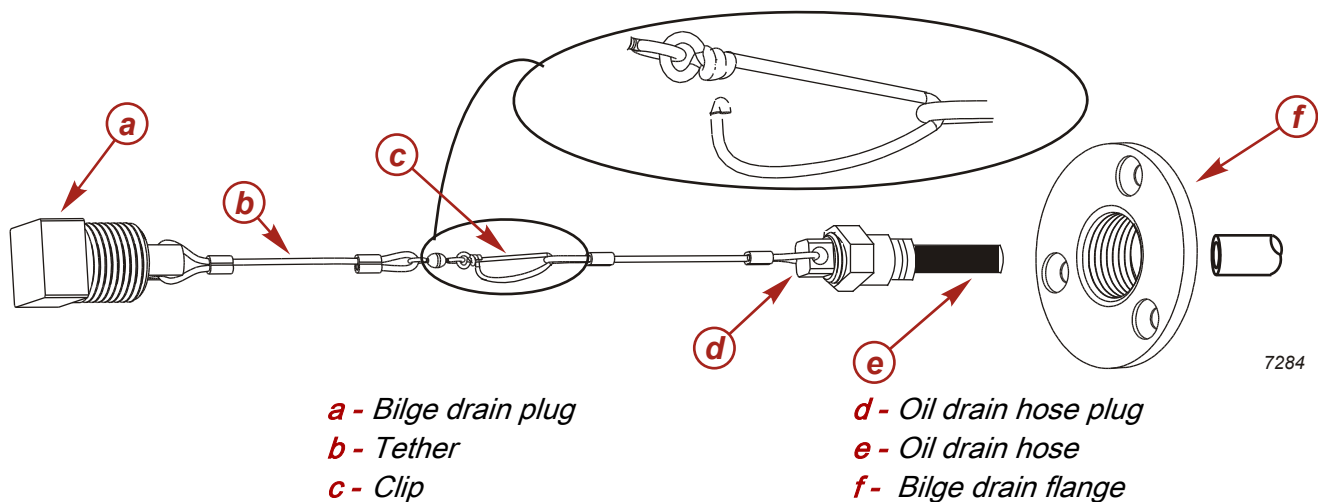

4. Place the oil drain hose in a suitable container.
5. Remove the drain plug from the oil drain hose.
6. After oil has drained completely, install the drain plug in the oil drain hose.
7. Push the hose through bilge drain and install the plug.

## ENGINE OIL DRAIN PUMP

1. Loosen the oil filter to vent the system.
2. Remove the dipstick.
3. Install the oil pump onto the dipstick tube.

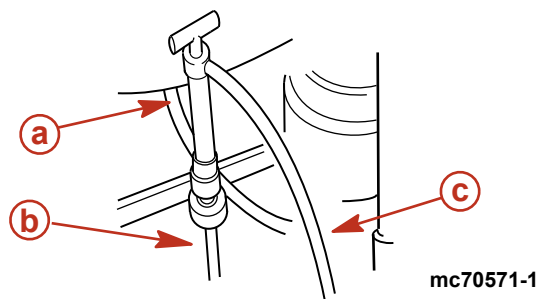

4. Insert the hose end of the crankcase oil pump onto an appropriate container and, using the handle, pump until the crankcase is empty.
5. Remove the pump.
6. Install the dipstick.

## CHANGING FILTER

1. Remove and discard oil filter.

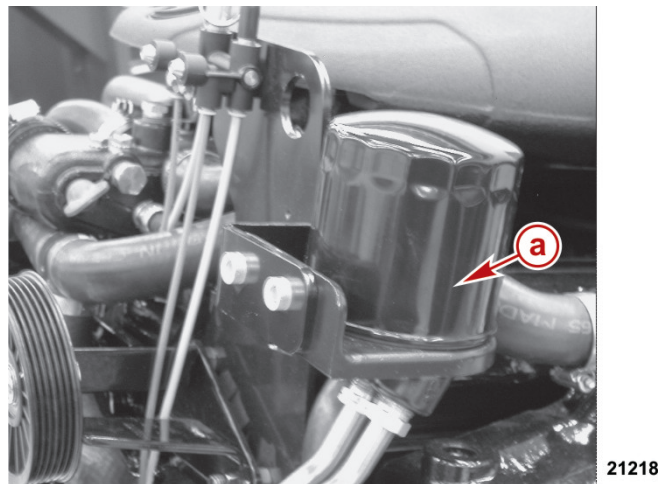
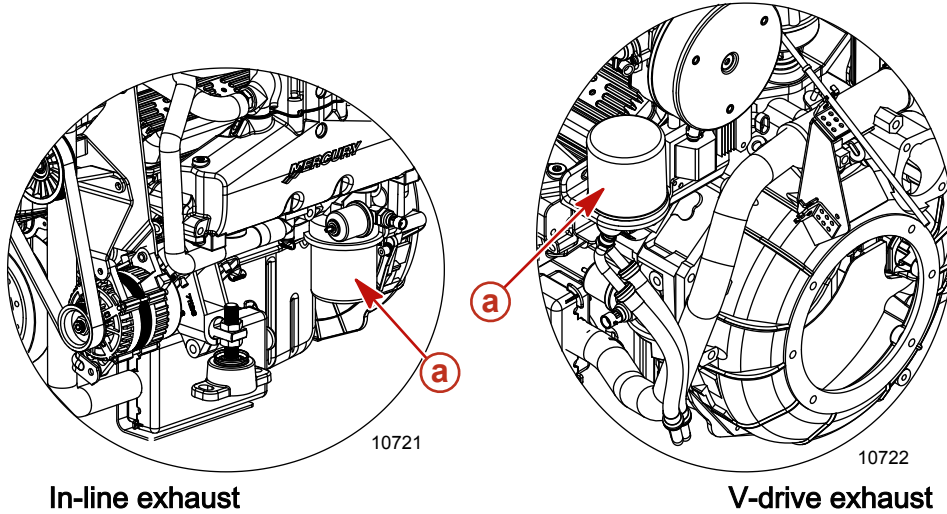

In-line exhaust with remote oil filter

**a** - Oil filter

2. Coat sealing ring on new filter with engine oil and install.
  3. Tighten oil filter securely (following filter manufacturer's instructions). Do not overtighten.
  4. Remove oil fill cap.
- IMPORTANT:** Always use dipstick to determine exactly how much oil is required.
5. Add recommended engine oil to bring level up to the bottom of the OK range on the dipstick.
  6. With the boat at rest in the water, check the oil level and add specified fluid to bring the oil level up to, but not over, the full or OK range.

**NOTE:** Adding 0.95 liters (1 quart) of engine oil will raise the level from the add mark to the top of the OK range.

Models	Capacity	Fluid Type
Engine Oil (With Filter)	4.25 liters (4.5 U.S. Quart)	Mercury/Quicksilver Synthetic Blend MerCruiser Engine Oil 25W-40

7. Start the engine, run the engine for three minutes, and check for leaks. Stop the engine. Allow approximately 5 minutes for the oil to drain into the oil pan. The boat must be at rest in the water.

## Transmission Fluid

### Checking While the Engine is Warm

1. Velvet Drive Transmissions - Stop the engine and immediately check fluid level by turning T-handle counterclockwise, to remove dipstick. Fluid level should be up to full mark. If low, add specified fluid through dipstick tube on transmissions.
2. ZF Marine Transmissions - Stop the engine and remove the dipstick to check level. If fluid is below top (full) line, add specified fluid through dipstick hole. Do not overfill. Reinstall dipstick with cap fully seated.
3. Walter V-Drive Transmissions - Stop the engine and remove the dipstick to check the level. If the fluid is below the top (full) line, add the specified fluid through the breather elbow. Do not overfill. Reinstall the dipstick with the cap fully seated.

### Checking While Engine is Cold

**NOTE:** Cold fluid level check: To ease checking the fluid level, the dipstick can be marked or scribed with a cold level mark.

1. Follow the procedure for the warm fluid level check, then allow the boat to sit overnight.

**IMPORTANT:** Be sure to push the dipstick all the way down into the dipstick tube when checking the fluid level.

2. Remove the dipstick, wipe clean and reinsert.
3. Remove the dipstick, observe the fluid level and mark the cold fluid level.
4. Reinstall the dipstick, tighten the T-handle securely. Do not overtighten.

## Changing

Contact your authorized Mercury MerCruiser dealer.

## IAC Muffler

### Changing

Contact your authorized Mercury MerCruiser dealer.

## Cleaning The Flame Arrestor

### WARNING

Avoid gasoline fire or explosion. Gasoline is extremely flammable and highly explosive under certain conditions. Be careful when cleaning flame arrestor; ensure that ignition is off. Do not smoke or allow sources of spark or open flame in area when cleaning flame arrestor.

1. Remove the engine cover.
2. Disconnect and remove the crankcase ventilation hose from the fitting on the flame arrestor and valve cover.
3. Remove the flame arrestor.



**⚠ WARNING**

Avoid gasoline fire or explosion. Gasoline is extremely flammable and highly explosive under certain conditions. Never use gasoline as a cleaning solvent.

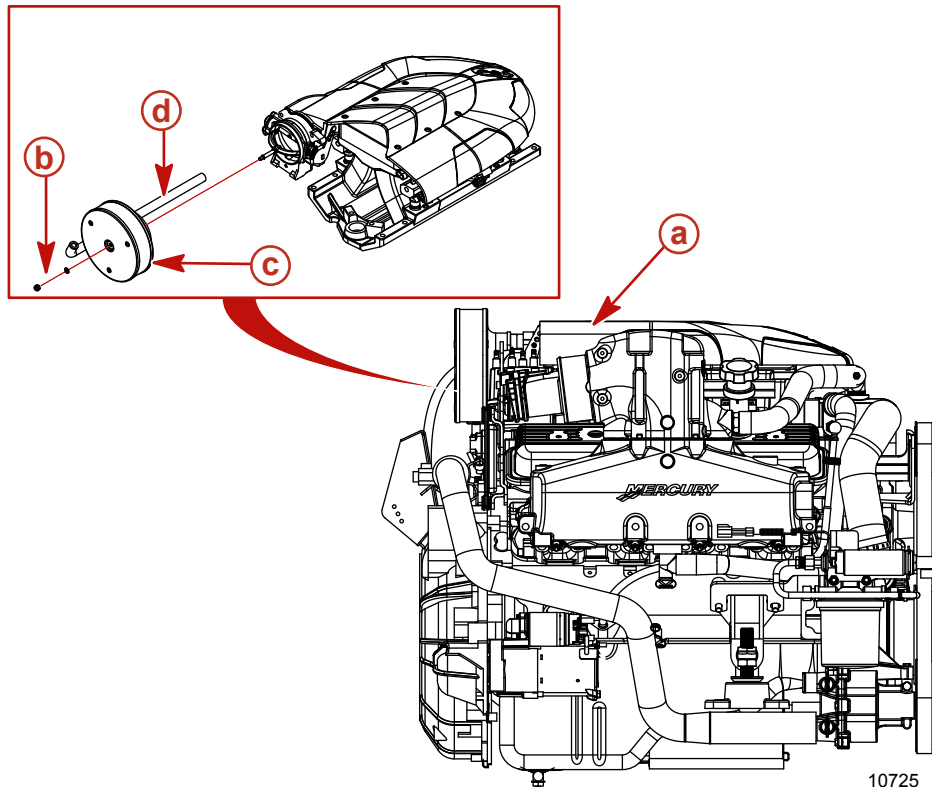

- a** - Plenum  
**b** - Flame arrester and washer  
**c** - Flame arrester  
**d** - Crankcase ventilation hose

4. Clean the flame arrester with solvent. Dry with compressed air or allow to air dry completely.
5. Clean the crankcase ventilation hose with warm water and a mild detergent. Dry with compressed air or allow to air dry completely.
6. Inspect the crankcase ventilation hose for cracks or deterioration. Replace if necessary.
7. Install the flame arrester and flame arrester bracket. Torque the flame arrester bracket nuts.

Description	Nm	lb. in.	lb. ft.
Flame arrester bracket nut	12	106	

8. Connect the crankcase ventilation hose to the fitting on the flame arrester and valve cover.
9. Install the engine cover.

## Positive Crankcase Ventilation Valve (PCV) CHANGING

**IMPORTANT:** Use only Mercury MerCruiser replacement parts to ensure compliance with emission regulations.

**NOTE:** On V6 models the PCV valve is non-serviceable and is an internal component of the valve cover.

1. Remove the PCV valve from the port valve cover.

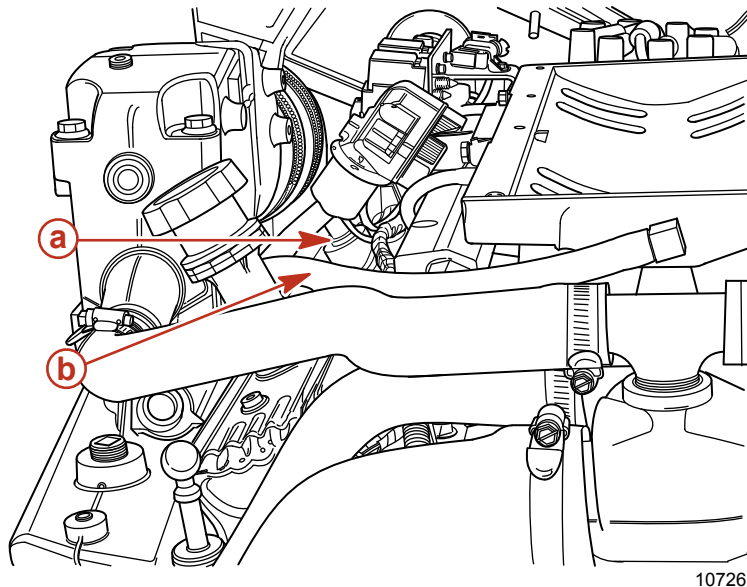

**a** - PCV valve

**b** - Hose

2. Disconnect the PCV valve from the hose and discard the valve.
3. Install a new PCV valve in the valve cover and reconnect the hose.
4. Ensure the PCV valve is tightly seated in the valve cover.

## Changing Water Separating Fuel Filter

### ⚠ WARNING

Avoid serious injury or death from a gasoline fire or explosion; gasoline is extremely flammable and highly explosive under certain conditions. When servicing the fuel system components ensure that the engine is cool, the ignition switch is in the off position, and that the lanyard stop switch, if equipped, is in the off position. Do not smoke or allow spark or open flame in the area. Wipe up any spilled fuel immediately. Ensure that no fuel leaks exist before closing the engine hatch.

1. Allow the engine to cool down.
- NOTE:** Mercury MerCruiser recommends that the engine be shut off for 12 hours prior to filter removal.
2. Close fuel supply valve, if equipped.
  3. Wrap the water separating fuel filter with a cloth to help catch any fuel spills or spray.
  4. Remove and discard the water separating fuel filter and sealing ring from the mounting bracket.
  5. Coat the sealing ring on the new filter with engine oil.

Tube Ref. No.	Description	Where Used	Part No.
	Synthetic Blend MerCruiser Engine Oil SAE25W-40	Filter sealing ring	92-883725K01

- Thread filter onto the mounting bracket and tighten securely by hand. Do not use a filter wrench.

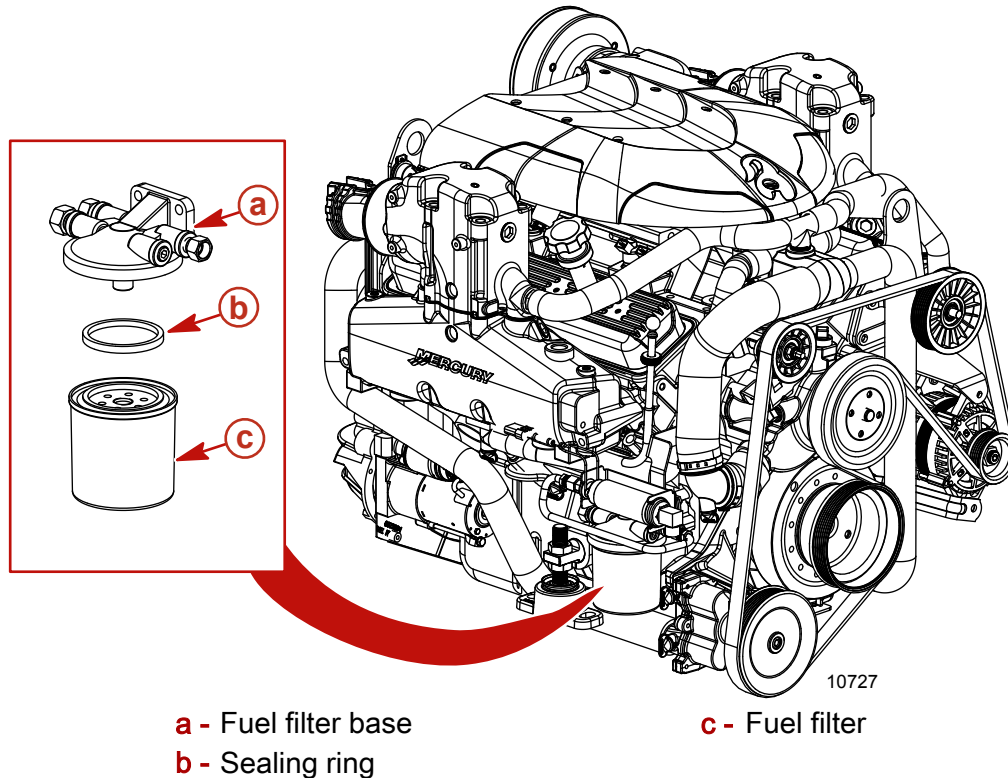

- Open fuel supply valve, if equipped.
- Ensure that engine compartment is properly ventilated.
- Supply cooling water to the engine.
- Start the engine. Check for gasoline leaks around the fuel filter assembly. If leaks exist, stop the engine immediately. Recheck the filter installation, clean spilled fuel and properly ventilate the engine compartment. If leaks continue, stop engine immediately and contact your authorized Mercury MerCruiser dealer.

## In-line Fuel Filter

### ⚠ WARNING

Avoid serious injury or death from a gasoline fire or explosion; gasoline is extremely flammable and highly explosive under certain conditions. When servicing the fuel system components ensure that the engine is cool, the ignition switch is in the off position, and that the lanyard stop switch, if equipped, is in the off position. Do not smoke or allow spark or open flame in the area. Wipe up any spilled fuel immediately. Ensure that no fuel leaks exist before closing the engine hatch.

- Allow the engine to cool down.  
**NOTE:** Mercury MerCruiser recommends that the engine be shut off for 12 hours prior to filter removal.
- Close fuel supply valve, if equipped.
- Wrap the water separating fuel filter with a cloth to help catch any fuel spills or spray.
- Remove and discard the in-line fuel filter.



Description	Nm	lb. in.	lb. ft.
Hose clamps	3.4-6.8	30-60	

11. Open fuel supply valve, if equipped.
12. Ensure that engine compartment is properly ventilated.
13. Supply cooling water to the engine.
14. Start the engine. Check for gasoline leaks around the fuel filter assembly. If leaks exist, stop the engine immediately. Recheck the filter installation, clean spilled fuel and properly ventilate the engine compartment. If leaks continue, stop engine immediately and contact your authorized Mercury MerCruiser dealer.

## Lubrication

### Throttle Cable

1. Lubricate the pivot points and the guide contact surfaces.

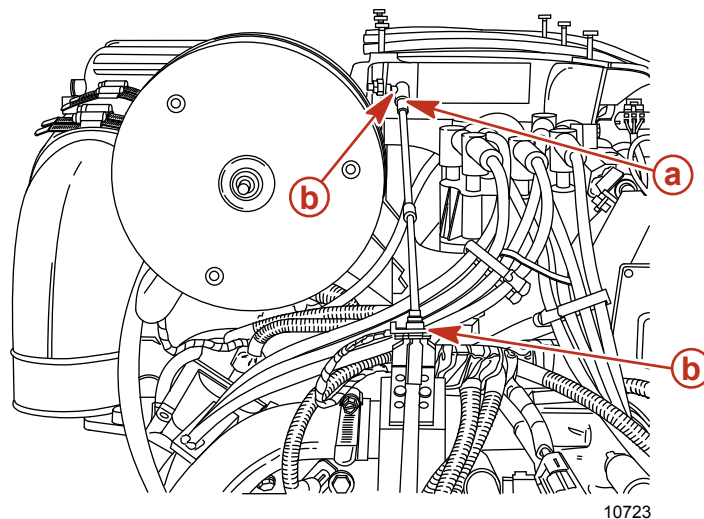

**a** - Pivot points

**b** - Guide contact surfaces

Tube Ref. No.	Description	Where Used	Part No.
	Synthetic Blend MerCruiser Engine Oil SAE25W-40	Throttle cable pivot points & guide contact surfaces	92-883725K01

### Transmission Linkage

**IMPORTANT:** The poppet ball must be centered in the detent hole for each F-N-R position.

1. Lubricate the detent ball and the holes in the shift lever.

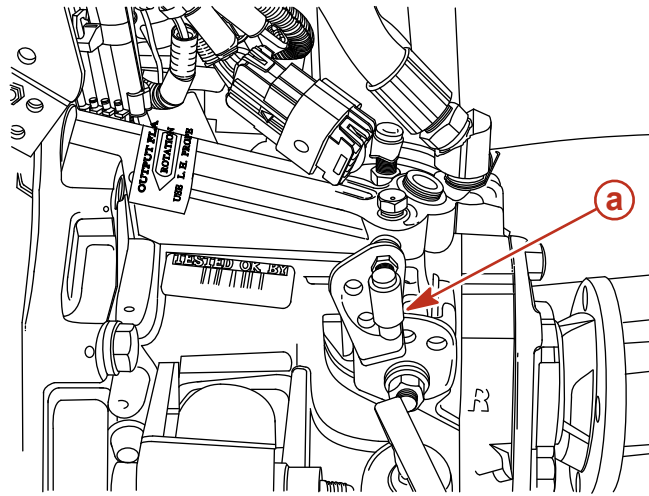

10724

**In-Line Transmission**

Tube Ref. No.	Description	Where Used	Part No.
	Synthetic Blend MerCruiser Engine Oil SAE25W-40	Detent ball and shift lever holes	92-883725K01

2. Lubricate the shift cable pivot points.

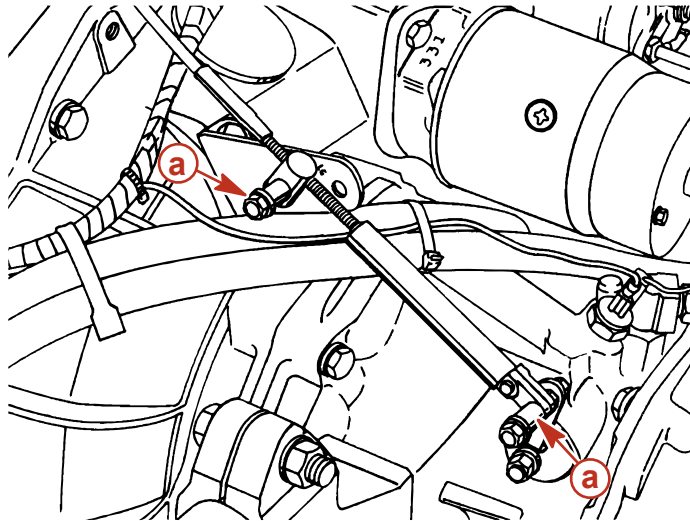

5935

**a** - Pivot points

Tube Ref. No.	Description	Where Used	Part No.
	Synthetic Blend MerCruiser Engine Oil SAE25W-40	Shift cable pivot points	92-883725K01

## Serpentine Drive Belt

### ⚠ WARNING

Avoid possible serious injury. Make sure that the engine is turned off and the ignition key is removed before inspecting belts.

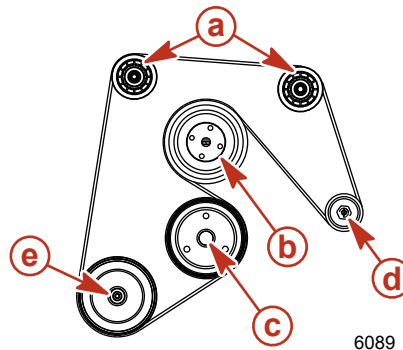

6089

**a** - Idler pulley

**b** - Circulating pump pulley

**c** - Crankshaft pulley

**d** - Alternator pulley

**e** - Seawater pump pulley

## Checking

1. Inspect the drive belt for proper tension and for the following:

- Excessive wear
- Cracks

**NOTE:** *Minor, transverse cracks (across the belt width) may be acceptable. Longitudinal cracks (in the direction of belt length) that join transverse cracks are NOT acceptable.*

- Fraying
- Glazed surfaces
- Proper tension - 13 mm (1/2 in.) deflection, with moderate thumb pressure, on the belt at the location that has the longest distance between two pulleys.

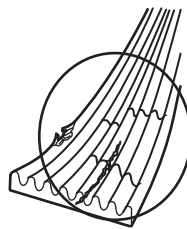

mc75130-1

## Replacing Belt and/or Adjusting Tension

**IMPORTANT:** If a belt is to be reused, it should be installed in the same direction of rotation as before.

**NOTE:** *Belt deflection is to be measured on the belt at the location that has the longest distance between two pulleys.*

1. Loosen the 16 mm (5/8 in.) locking nut on the adjustment stud.
2. Turn the adjustment stud and loosen the belt.
3. If a new serpentine drive belt is required, remove the old belt and install a new belt onto the pulleys.
4. Put a wrench on the adjustment stud 16 mm (5/8 in.) locking nut.

5. Use a 8 mm (5/16 in.) socket and tighten adjusting the stud to adjust the belt deflection.
6. Using one of the 2 methods following, check for correct deflection.
  - a. Push down with moderate thumb pressure on the longest stretch of belt. Proper deflection is 13 mm (1/2 in.).
  - b. Attach the Kent Moore© Belt Tension Gauge to the belt. The gauge has different ranges for new and used belts.

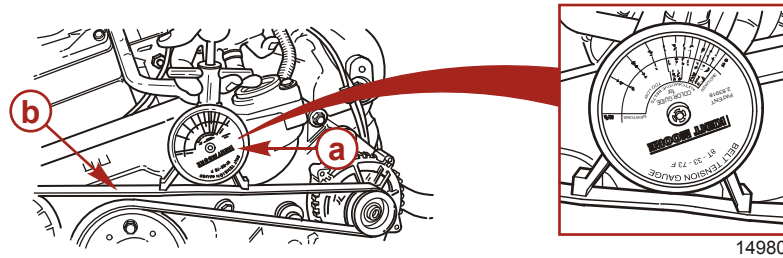

**a** - Kent Moore© Tension Gauge

**b** - Serpentine belt

7. While holding the adjustment stud at the correct belt tension, tighten the 16 mm (5/8 in.) locking nut.

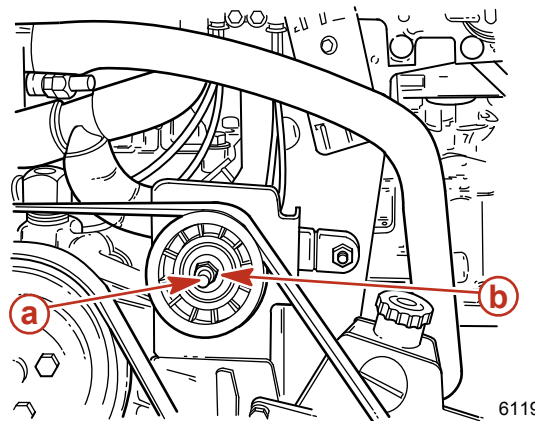

**a** - 8 mm (1/16 in.) adjusting stud

**b** - 16 mm (5/8 in.) locking nut

8. Operate the engine for a short period of time and recheck the belt adjustment.

## Flushing The Power Package—Tow Sports

### The Boat Out of the Water

**IMPORTANT:** Flushing the power package is most effective when performed with the boat out of the water.

**IMPORTANT:** Flushing is needed if the engine package has been operated in salty, brackish, mineral-laden or polluted water. For best results flushing is recommended after each outing and before cold weather and extended storage.

#### **⚠ WARNING**

Contact with moving drive components and the propeller can cause personal injury or death. To avoid possible injury, remove the propeller and ensure that no people or animals are in the area of the drive unit while flushing.

1. **Models with Walter V-Drive Transmissions:**



- a. Close the seacock, if equipped, and then disconnect the seawater inlet hose from the transmission seawater inlet fitting.
- b. If not equipped with a seacock, disconnect the seawater inlet hose from the transmission seawater inlet fitting and plug the seawater inlet hose.

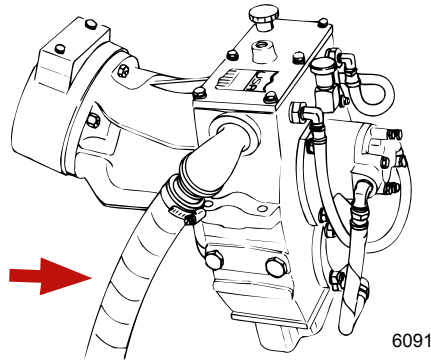

- c. Using appropriate connector, connect the flushing water hose to the transmission seawater inlet fitting.
  - d. Proceed to step 3
2. **All other models:**
- a. Close the seacock, if equipped, and then disconnect the seawater inlet hose from the seawater pump inlet fitting..
  - b. If not equipped with a seacock, disconnect the seawater inlet hose from the seawater pump and plug the hose.

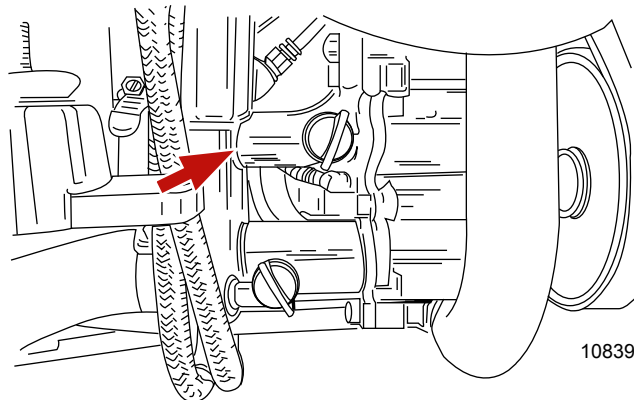

- c. Using a suitable adapter, connect the flushing hose from the water source to the water inlet of the seawater pump.
- d. Proceed to step 3.

**⚠ CAUTION**

Flush water will collect in the exhaust system when the engine is not operating, resulting in engine damage. Do not supply flush water for more than 15 seconds without the engine operating.

3. Completely open the water source to provide maximum water supply.
4. Place the remote control in the neutral idle speed position.
5. Immediately start the engine.

**⚠ CAUTION**

Avoid engine damage from overheating. If the engine is operated above 1400 RPM during flushing, suction created by the seawater pickup pump may collapse the flushing water hose, causing the engine to overheat.

6. Depress the throttle only button and slowly advance the throttle until the engine reaches 1300 RPM ( $\pm$  100 RPM).

**⚠ CAUTION**

Engine overheating can cause engine damage. To avoid, observe the water temperature gauge and ensure that the engine is operating in the normal range.

7. Observe the water temperature gauge to ensure that the engine is operating in the normal range.
8. Operate the engine with the transmission in neutral for a minimum of 10 minutes.
9. *For power packages operated in salty, brackish, mineral-laden or polluted water:* Continue to operate the engine until the discharge water is clear.
10. Slowly return the throttle to idle speed position.

**⚠ CAUTION**

Flush water will collect in the exhaust system when the engine is not operating, resulting in engine damage. Do not supply flush water for more than 15 seconds without the engine operating.

11. Stop the engine.
12. Immediately shut off the supply water and remove the flushing attachment.
13. Install the water inlet hose to the seawater inlet of the seawater pump or V-Drive water inlet.
14. Tighten hose clamp securely.
15. Attach to the next engine, if equipped, and repeat procedure.

## The Boat In the Water

**IMPORTANT:** Flushing the power package is most effective when performed with the boat out of the water.

**IMPORTANT:** Flushing is needed if the engine package has been operated in salty, brackish, mineral-laden or polluted water. For best results flushing is recommended after each outing and before cold weather and extended storage.

**⚠ CAUTION**

Excess water in the bilge can damage the engine or cause the boat to sink. Disconnecting the seawater inlet hose will cause water to enter the bilge. Close the seacock, if equipped, before disconnecting the seawater inlet hose.

1. **Models with Walter V-Drive Transmissions:**
  - a. Close the seacock, if equipped, and then disconnect the seawater inlet hose from the transmission seawater inlet fitting.

**⚠ CAUTION**

Excess water in the bilge can damage the engine or cause the boat to sink. Disconnecting the seawater inlet hose will cause water to enter the bilge. Disconnect and immediately plug the seawater inlet hose to prevent water from siphoning into the engine or boat.

- b. If not equipped with a seacock, disconnect the seawater inlet hose from the transmission seawater inlet fitting and immediately plug the seawater inlet hose to prevent water from siphoning into the engine or boat.

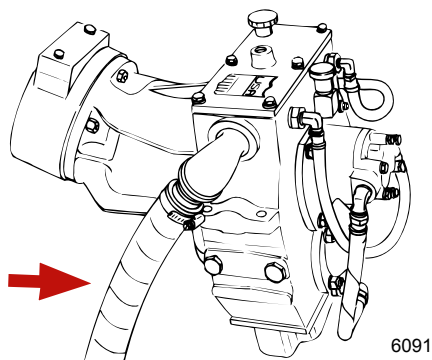

6091

- c. Using suitable adapter, connect the flushing water hose to the transmission seawater inlet fitting.
- d. Proceed to step 3

**2. All other models:**

- a. Close the seacock, if equipped, and then disconnect the seawater inlet hose from the seawater pump inlet fitting.

**⚠ CAUTION**

Excess water in the bilge can damage the engine or cause the boat to sink. Disconnecting the seawater inlet hose will cause water to enter the bilge. Close the seacock, if equipped, before disconnecting the seawater inlet hose.

- b. If not equipped with a seacock, disconnect the seawater inlet hose from the seawater pump inlet fitting and immediately plug the seawater inlet hose to prevent water from siphoning into the engine or boat.

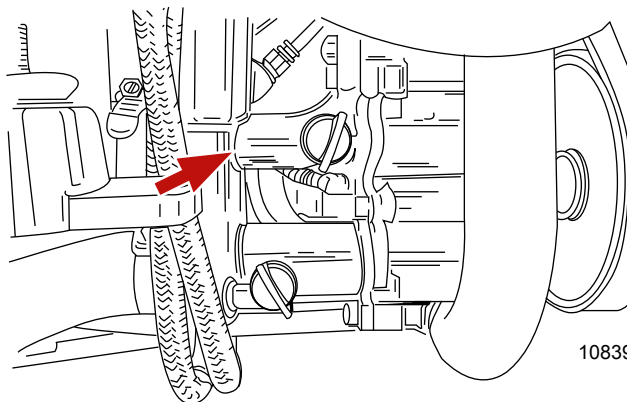

10839

- c. Using a suitable adapter, connect the flushing hose from the water source to the water inlet of the seawater pump.
- d. Proceed to step 3.

**⚠ CAUTION**

Flush water will collect in the exhaust system when the engine is not operating, resulting in engine damage. Do not supply flush water for more than 15 seconds without the engine operating.

3. Completely open the water source to provide maximum water supply.
4. Place the remote control in the neutral idle speed position.
5. Immediately start the engine.

**⚠ CAUTION**

Avoid engine damage from overheating. If the engine is operated above 1400 RPM during flushing, suction created by the seawater pickup pump may collapse the flushing water hose, causing the engine to overheat.

6. Depress the throttle only button and slowly advance the throttle until the engine reaches 1300 RPM ( $\pm$  100 RPM).

**⚠ CAUTION**

Engine overheating can cause engine damage. To avoid, observe the water temperature gauge and ensure that the engine is operating in the normal range.

7. Observe the water temperature gauge to ensure that the engine is operating in the normal range.
8. Operate the engine with the transmission in neutral for a minimum of 10 minutes.
9. *For power packages operated in salty, brackish, mineral-laden or polluted water:* Continue to operate the engine until the discharge water is clear.
10. Slowly return the throttle to idle speed position.

**⚠ CAUTION**

Flush water will collect in the exhaust system when the engine is not operating, resulting in engine damage. Do not supply flush water for more than 15 seconds without the engine operating.

11. Stop the engine.
12. Immediately shut off the water supply and remove the flushing attachment.
13. Remove the flushing connector from the water inlet.
14. Tag the ignition switch with an appropriate tag requiring the seacock to be opened or the seawater inlet hose to be reconnected prior to operating the engine.
15. Repeat the flushing procedure on the next engine, if equipped.

## Battery

Refer to specific instructions and warnings accompanying your battery. If this information is not available, observe the following precautions when handling a battery.

**⚠ WARNING**

Avoid serious injury from fire or explosion. Do not use jumper cables and a booster battery to start engine. Do not recharge a weak battery in the boat. Remove battery and recharge in a ventilated area away from fuel vapors, sparks or flames.

**⚠ WARNING**

Batteries contain acid which can cause severe burns. Avoid contact with skin, eyes and clothing. If electrolyte is spilled or splashed on any part of the body, immediately flush the exposed area with liberal amounts of water and obtain medical aid as soon as possible. Safety glasses and rubber gloves are recommended when handling batteries or filling with electrolyte.

## Multiple EFI Engine Battery Precautions

**Alternators:** Alternators are designed to charge the battery that supplies electrical power to the engine that the alternator is mounted on. When batteries for 2 different engines are connected, one alternator will supply all of the charging current for both batteries. Normally, the other engine's alternator will not be required to supply any charging current.

**EFI Electronic Control Module (ECM):** The ECM requires a stable voltage source. During multiple engine operation, an onboard electrical device may cause a sudden drain of voltage at the engine's battery. The voltage may go below the ECM's minimum required voltage. Also, the alternator on the other engine may now start charging. This could cause a voltage spike in the engine's electrical system.

In either case, the ECM could shut off. When the voltage returns to the range that the ECM requires, the ECM will reset itself, and the engine will operate normally. The ECM shuts off and resets itself so quickly that the engine may only seem to have an ignition miss.

**Batteries:** Boats with multi-engine EFI power packages require each engine be connected to its own battery. This ensures that the engine's ECM has a stable voltage source.

**Battery Switches:** Battery switches should always be positioned so each engine is operating off of its own battery. Do not operate engines with switches in both or all position. In an emergency, another engine's battery can be used to start an engine with a dead battery.

**Battery Isolators:** Isolators can be used to charge an auxiliary battery used for powering accessories in the boat. They should not be used to charge the battery of another engine in the boat unless the type of isolator is specifically designed for this purpose.

**Generators:** The generators battery should be considered another engine's battery.

## Notes:

## Section 6 - Storage

### Table of Contents

Cold Weather or Extended Storage.....	72	Boat out of the Water .....	79
Preparing Power Package for Storage.....	72	Manual Single Point Drain System.....	81
Engine and Fuel System Preparation ....	73	Boat in the Water .....	81
Draining the Seawater System.....	74	Boat out of the Water .....	82
Drain System Identification.....	74	Three Point Manual Drain System.....	83
Air Actuated Single Point Drain System		Boat in the Water .....	83
.....	74	Boat out of the Water .....	84
Manual Single Point Drain System .....	75	Multi-Point Drain (MPD) System.....	85
Three Point Manual Drain System .....	75	Boat out of the Water .....	85
Multi-Point Drain (MPD) System .....	76	Boat in the Water .....	87
Air Actuated Single Point Drain System.....	76	Battery Storage.....	89
Boat in the Water .....	76	Power Package Recommissioning.....	89

## Cold Weather or Extended Storage

**IMPORTANT:** Mercury MerCruiser strongly recommends that this service should be performed by an authorized Mercury MerCruiser dealer. Damage caused by freezing temperatures IS NOT covered by the Mercury MerCruiser Limited Warranty.

### NOTICE

Avoid cooling system and engine damage. Water trapped in the seawater section of the cooling system can cause corrosion damage, freeze damage, or both. Ensure the seawater section of the cooling system is drained immediately after operation, or before any length of storage in cold weather, if the possibility of freezing temperatures exists. If the boat is in the water, keep the seacock closed until restarting the engine to prevent water from flowing back into the cooling system. If the boat is not fitted with a seacock, leave the water inlet hose disconnected and plugged.

*NOTE: As a precautionary measure, attach a tag to the key switch or steering wheel of the boat reminding the operator to open the seacock or unplug and reconnect the water inlet hose before starting the engine.*

**IMPORTANT:** Mercury MerCruiser requires that propylene glycol antifreeze, mixed to the manufacturers instructions, be used in the seawater section of the cooling system for freezing temperatures or extended storage. Make sure that the propylene glycol antifreeze contains a rust inhibitor and is recommended for use in marine engines. Be certain to follow the propylene glycol manufacturer's recommendations.

## Preparing Power Package for Storage

1. Fill the fuel tanks with fresh gasoline (that does not contain alcohol) and a sufficient amount of Quicksilver Gasoline Stabilizer for Marine Engines to treat the gasoline. Follow instructions on the container.
2. If the boat is to be placed in storage with fuel containing alcohol in fuel tanks (if fuel without alcohol is not available): Fuel tanks should be drained as low as possible and Mercury/Quicksilver Gasoline Stabilizer for Marine Engines added to any fuel remaining in the tank. Refer to **Fuel Requirements** for additional information.
3. Flush the cooling system. Refer to the **Maintenance** section.
4. For additional assurance against freezing and rust, after draining, fill the seawater cooling system with propylene glycol mixed to the manufacturer's recommendation to protect engine to the lowest temperature to which it will be exposed during freezing temperatures or extended storage.
5. Operate the engine sufficiently to bring it up to normal operating temperature and allow fuel with Mercury/Quicksilver Gasoline Stabilizer to circulate through the fuel system. Shut off the engine.
6. Change the oil and oil filter.
7. Prepare the engine and fuel system for storage. Refer to **Engine and Fuel System Preparation**. Perform this operation.
8. Drain the engine seawater cooling system. Refer to **Draining the Seawater System**.



**NOTICE**

Avoid cooling system and engine damage. Water trapped in the seawater section of the cooling system can cause corrosion damage, freeze damage, or both. Ensure the seawater section of the cooling system is drained immediately after operation, or before any length of storage in cold weather, if the possibility of freezing temperatures exists. If the boat is in the water, keep the seacock closed until restarting the engine to prevent water from flowing back into the cooling system. If the boat is not fitted with a seacock, leave the water inlet hose disconnected and plugged.

9. Store the battery according to the manufacturer's instructions.



**ENGINE AND FUEL SYSTEM PREPARATION****⚠ WARNING**

Avoid serious injury or death from a gasoline fire or explosion; gasoline is extremely flammable and highly explosive under certain conditions. When servicing the fuel system components ensure that the engine is cool, the ignition switch is in the off position, and that the lanyard stop switch, if equipped, is in the off position. Do not smoke or allow spark or open flame in the area. Wipe up any spilled fuel immediately. Ensure that no fuel leaks exist before closing the engine hatch.

**⚠ WARNING**

Fuel vapors can be present in the engine compartment. Avoid injury or power package damage caused by fuel vapors or explosion. Always ventilate the engine compartment prior to servicing the power package.

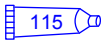
1. In a 23 liter (6 U.S.gal.) remote fuel tank mix:
  - a. 19 liter (5 U.S. gal) regular unleaded 87 octain (90 RON) gasoline
  - b. 1.89 liter (2 U.S. qts.) Premium Plus 2-Cycle TC-W3 Outboard Oil
  - c. 150 ml (5 ounces) Fuel System Treatment and Stabilizer or 30 ml (1 ounce) Fuel System Treatment and Stabilizer Concentrate

Tube Ref No.	Description	Where Used	Part No.
 115	Premium Plus 2-cycle TC-W3 Outboard Oil	Fuel system	92-802824A1
 124	Fuel System Treatment & Stabilizer	Fuel system	802875A1

2. Allow the engine to cool down.

**IMPORTANT: Immediately wipe up any fuel spills or sprays.**

3. Close the fuel shut off valve, if equipped. Disconnect and plug the fuel inlet fitting if not equipped with a fuel shut off valve.
4. Connect the remote fuel tank (with the fogging mixture) to the fuel inlet fitting.

**IMPORTANT: Supply cooling water to the engine.**

5. Start and operate the engine at 1300 rpm for 5 minutes.
6. After specified operating time is complete, slowly return throttle to idle rpm and shut engine off.

**IMPORTANT: Ensure that some fogging mixture remains in the engine. Do not allow the engines fuel system to become completely dry.**

- Replace the water separating fuel filter element. Refer to Section 5 for proper procedure.

## Draining the Seawater System

### ⚠ CAUTION

Excess water in the bilge can damage the engine or cause the boat to sink. Ensure that the boat is out of the water, the seacock is closed (if equipped) or the seawater inlet hose is disconnected and plugged on both ends, and the bilge pump is operating before beginning the draining procedure.

### ⚠ CAUTION

Excess water in the bilge can damage the engine or cause the boat to sink. When the drain system is open, excess water can enter the bilge. Do not operate the engine with the drain system open.

**IMPORTANT:** Only drain the seawater section of the closed-cooling system.

**IMPORTANT:** The boat must be as level as possible to ensure complete draining of the cooling system.

Your power package is equipped with a drain system. Refer to **Drain System Identification** to determine which instructions apply to your power package.

**IMPORTANT:** The engine must not be operating at any point during the draining procedure.

**IMPORTANT:** Mercury MerCruiser requires that propylene glycol antifreeze, mixed to the manufacturer's instructions, be used in the seawater section of the cooling system for freezing temperatures or extended storage. Make sure that the propylene glycol antifreeze contains a rust inhibitor and is recommended for use in marine engines. Be certain to follow the propylene glycol manufacturer's recommendations.

## Drain System Identification

### AIR ACTUATED SINGLE POINT DRAIN SYSTEM

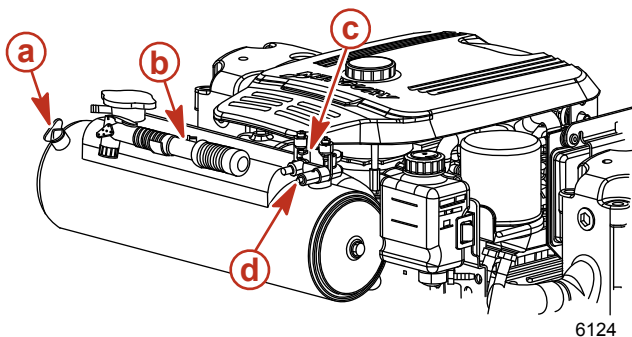

**Closed Cooled Models**

- a** - Blue drain plug location
- b** - Blue air pump

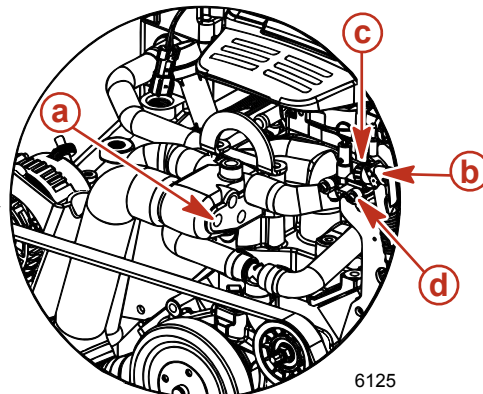

**Seawater Cooled Models**

- c** - Air manifold
- d** - Green indicators

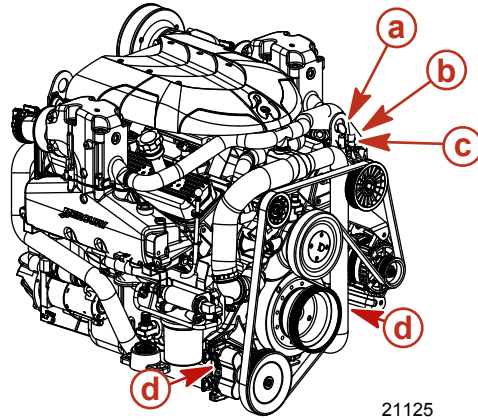

21125

**Black Scorpion Models**

- a** - Blue air pump
- b** - Air manifold

- c** - Green indicators
- d** - Blue drain plug locations

**MANUAL SINGLE POINT DRAIN SYSTEM**

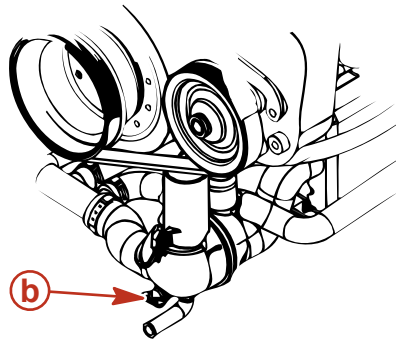
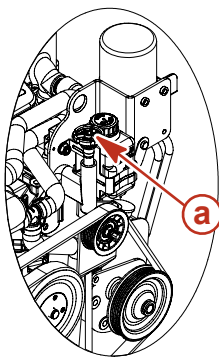

6128

- a** - Blue handle

- b** - Blue drain plug location

**THREE POINT MANUAL DRAIN SYSTEM**

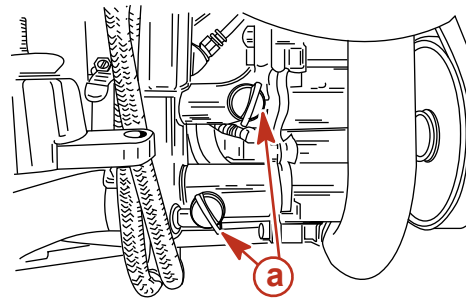
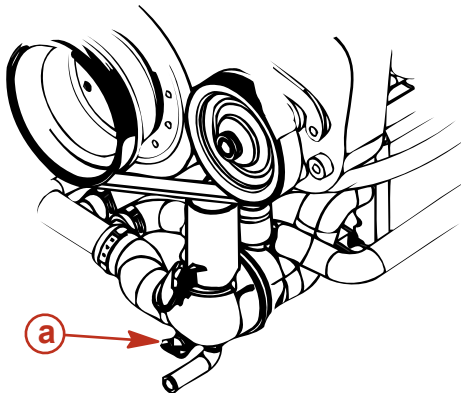

6126

- a** - Blue drain plug

## MULTI-POINT DRAIN (MPD) SYSTEM

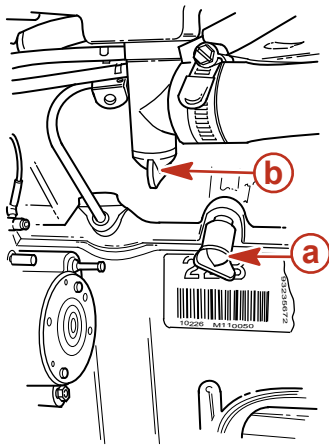

**a** - Side of cylinder block

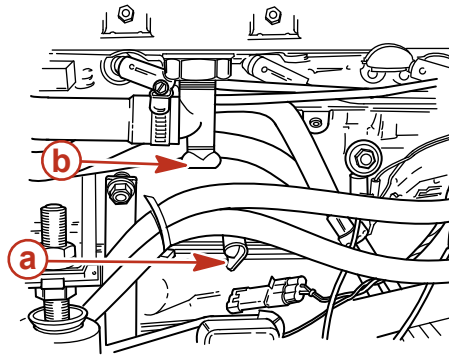

6129

**b** - Bottom of exhaust manifolds

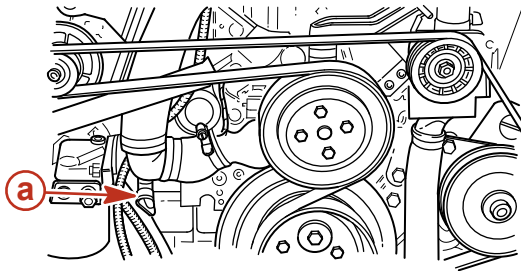

**a** - Water circulating pump hose

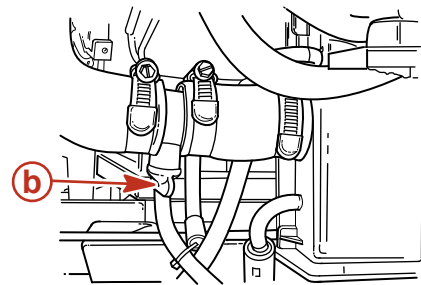

6130

**b** - Fuel cooler to thermostat housing

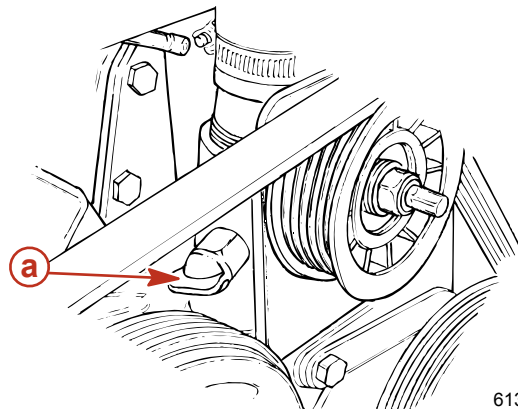

6131

**a** - Check valve (if equipped)

## Air Actuated Single Point Drain System

### BOAT IN THE WATER

**NOTE:** This procedure is written for the air pump that is attached to the engine. However, any air source can be used.

1. Close the seacock (if equipped) or remove and plug the water inlet hose.
2. Remove the air pump from the engine.
3. Ensure that the lever on top of the pump is flush with the handle (horizontal).
4. Install the air pump on the actuator fitting.

5. Pull lever on air pump (vertical) to lock pump on the fitting.

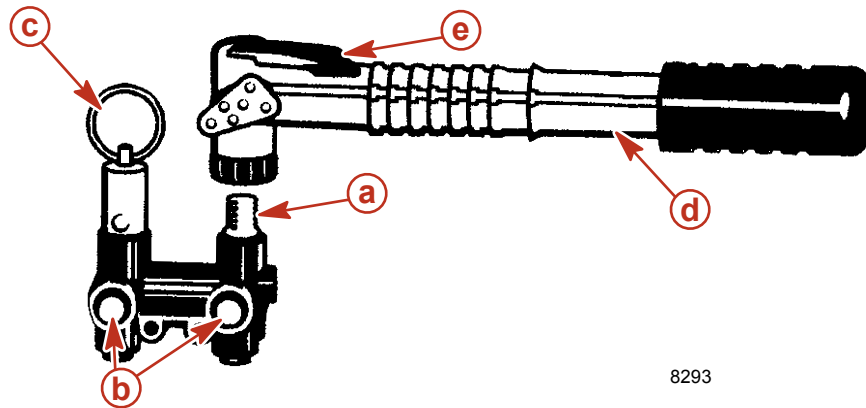

8293

- a** - Actuator fitting  
**b** - Green indicators  
**c** - Manual release valve  
**d** - Air pump  
**e** - Lever (locking)

6. Pump air into the system until both green indicators extend and water drains from both sides of the engine. The port side will begin draining before the starboard side.
7. Immediately remove the blue drain plug from the side of the thermostat housing or the heat exchanger. This must be removed within 30 seconds to properly vent the cooling system.

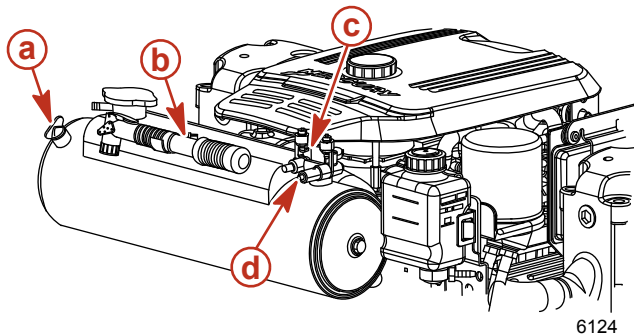

6124

#### Closed Cooled Models

- a** - Blue drain plug location  
**b** - Blue air pump

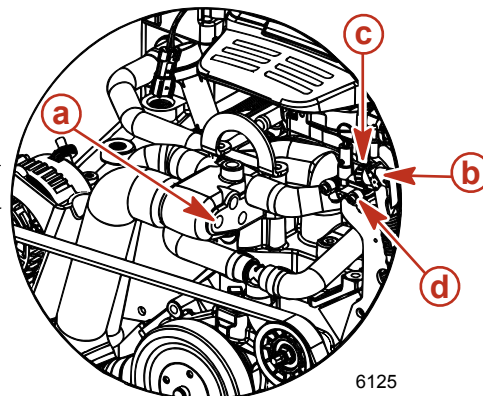

6125

#### Seawater Cooled Models

- c** - Air manifold  
**d** - Green indicators

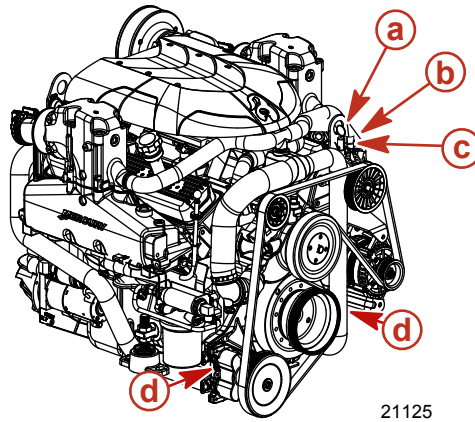

**Black Scorpion Models**

**a** - Blue air pump  
**b** - Air manifold

**c** - Green indicators  
**d** - Blue drain plug locations

8. Verify that water is draining from each opening. If not, use the **Three Point Manual Drain System** instructions.

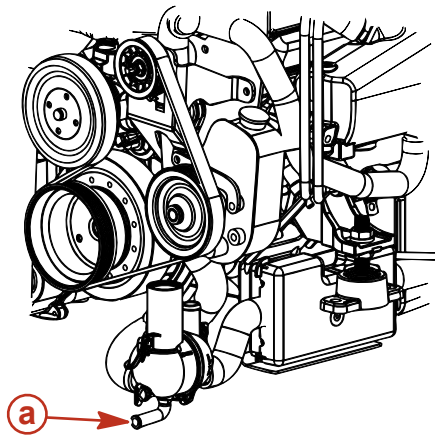

**a** - Port side drain location

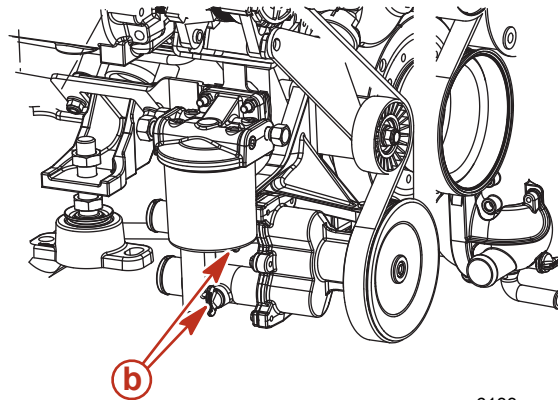

**b** - Starboard side drain location

6133

9. Allow the system to drain for a minimum of five minutes. Pump air as necessary to keep the green indicators extended.
10. Crank the engine over slightly with the starter motor to purge any water trapped in the seawater pump. Do not allow engine to start.
11. Reinstall the blue drain plug in the thermostat housing or heat exchanger.
12. Remove the air pump from the air manifold and return it to the mounting bracket.
13. Mercury MerCruiser recommends leaving the drain system open while transporting the boat or while performing other maintenance. This helps ensure that all water is drained.

14. Before launching the boat, pull up on the manual release valve. Verify that the green indicators are no longer extended.

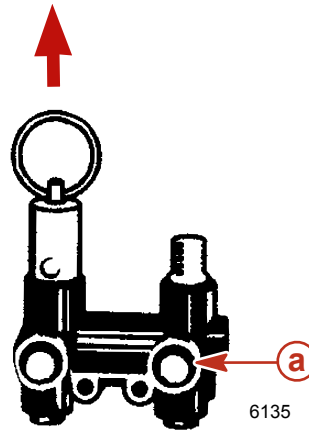

**a** - Green indicators

15. Open the seacock, if equipped, or unplug and reconnect the water inlet hose prior to operating the engine.

### BOAT OUT OF THE WATER

*NOTE: This procedure is written for the air pump that is attached to the engine. However, any air source can be used.*

1. Place the boat on a level surface to ensure complete draining of system.
2. Remove the air pump from the engine.
3. Ensure that the lever on top of the pump is flush with the handle (horizontal).
4. Install the air pump on the actuator fitting.
5. Pull lever on air pump (vertical) to lock pump on the fitting.

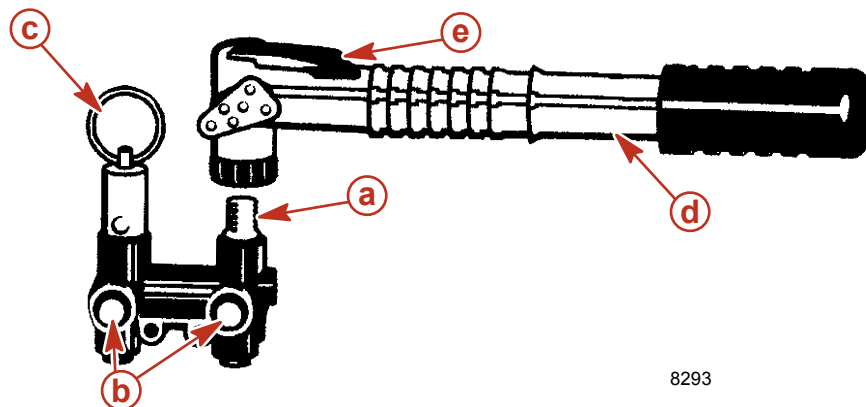

**a** - Actuator fitting  
**b** - Green indicators  
**c** - Manual release valve

**d** - Air pump  
**e** - Lever (locking)

- Pump air into the system until both green indicators extend and water drains from both sides of the engine. The port side will begin draining before the starboard side.

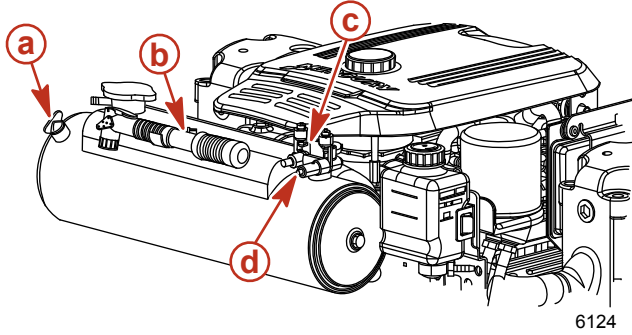

**Closed Cooled Models**

- a** - Blue drain plug location
- b** - Blue air pump

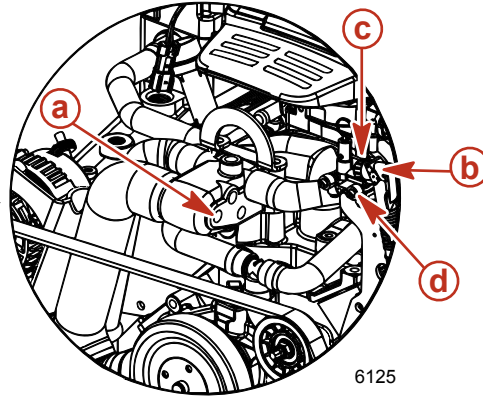

**Seawater Cooled Models**

- c** - Air manifold
- d** - Green indicators

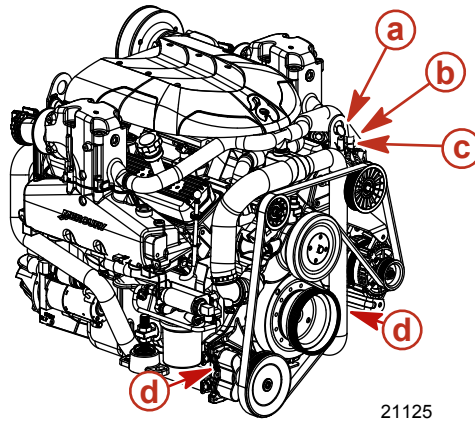

**Black Scorpion Models**

- a** - Blue air pump
- b** - Air manifold
- c** - Green indicators
- d** - Blue drain plug locations

- Verify that water is draining from each opening. If not, use the **Three Point Manual Drain System** instructions.

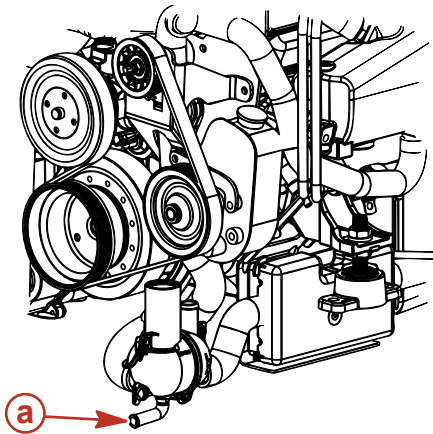

**a** - Port side drain location

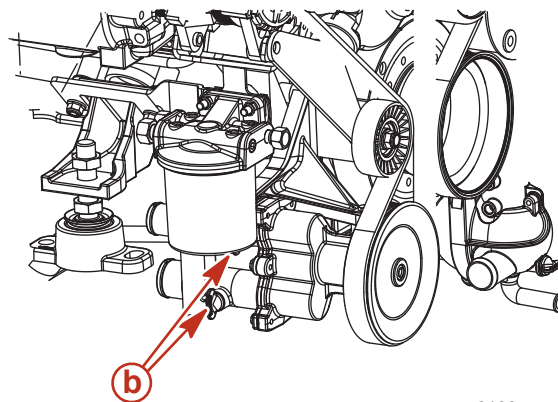

**b** - Starboard side drain location



8. Allow the system to drain for a minimum of five minutes. Pump air as necessary to keep the green indicators extended.
9. Crank the engine over slightly with starter motor to purge any water trapped in the seawater pump. Do not allow engine to start.
10. Remove the air pump from the air manifold and return it to the mounting bracket.
11. Mercury MerCruiser recommends leaving the drain system open while transporting the boat or while performing other maintenance. This helps ensure that all water is drained.
12. Before launching the boat, pull up on the manual release valve. Verify that the green indicators are no longer extended.

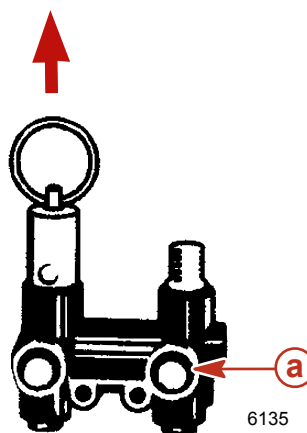

**a** - Green indicators

## Manual Single Point Drain System

### BOAT IN THE WATER

1. Close the seacock (if equipped) or remove and plug the water inlet hose.
2. Rotate the blue handle counterclockwise until it stops (approximately two turns). The red on the handle shaft indicates that the drain system is open. Do not force the handle as this will create new threads.
3. Immediately remove the blue drain plug from the side of the thermostat housing. This must be removed within 30 seconds to properly vent the cooling system.

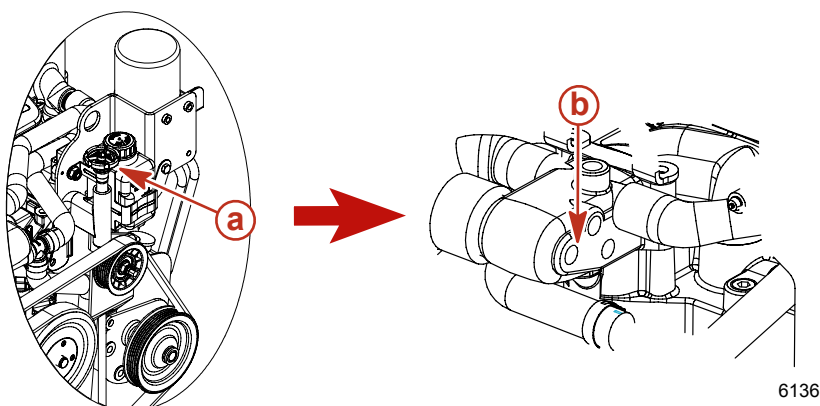

**a** - Blue handle

**b** - Blue drain plug location

4. Visually verify that water is draining. If water does not drain, remove the blue drain plug from the distribution housing and drain manually.

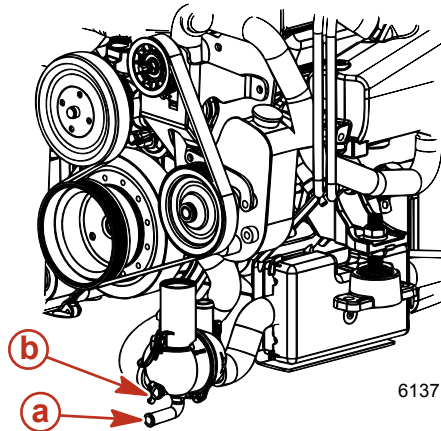

**a** - Drain location - orange or red      **b** - Blue drain plug

5. Allow the system to drain for a minimum of five minutes. Mercury MerCruiser recommends leaving the drain system open while transporting the boat or while performing other maintenance.
6. Reinstall the blue drain plug in the thermostat housing.
7. Close the drain system by rotating the blue handle clockwise until it stops and install the blue drain plug, if removed. The handle is fully seated when no red is visible. Do not overtighten the handle as this will create new threads.
8. Open the seacock (if equipped) or unplug and reconnect the water inlet hose prior to operating the engine.

## BOAT OUT OF THE WATER

1. Place the boat on a level surface to ensure complete draining of system.
2. Rotate the blue handle counterclockwise until it stops (approximately two turns). The red on the handle shaft indicates that the drain system is open. Do not overtighten the handle as this will create new threads.

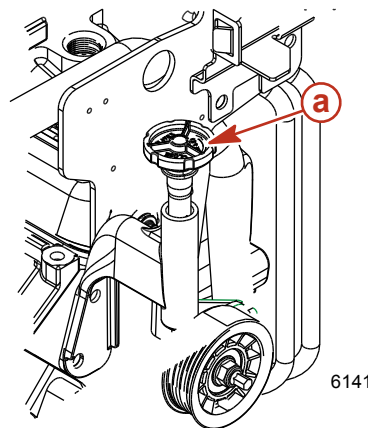

**a** - Blue handle

3. Visually verify that water is draining. If water does not drain, remove the blue drain plug from the distribution housing and drain manually.

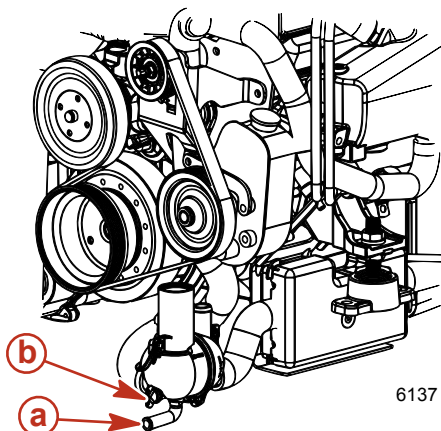

**a** - Drain location - orange or red      **b** - Blue drain plug

4. Allow the system to drain for a minimum of five minutes. Mercury MerCruiser recommends leaving the plugs out while transporting the boat or while performing other maintenance to ensure that all water is drained.
5. Close the drain system by rotating the blue handle clockwise until it stops or installing the blue drain plug. The handle is fully seated when no red is visible. Do not overtighten handle as this will create new threads.

## Three Point Manual Drain System

### BOAT IN THE WATER

**NOTE:** Use this procedure if your engine is not equipped with an air actuated single point drain system or if the air actuated single point drain system fails.

1. Close the seacock (if equipped) or remove and plug the water inlet hose.
2. Remove the blue drain plug from the distribution housing (lower front, port side).

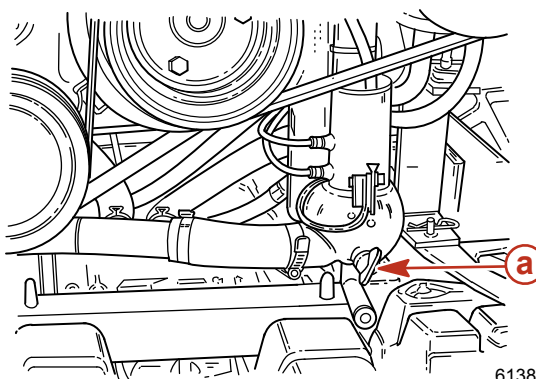

**a** - Blue drain plug

3. To properly vent the cooling system, remove the blue drain plug from the side of the thermostat housing within 30 seconds.

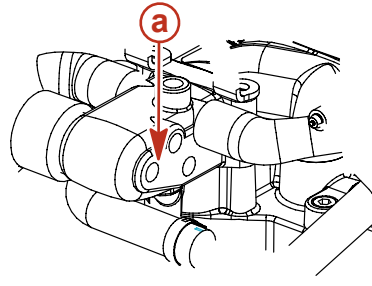

6139

**a** - Blue drain plug location

4. Remove the two blue drain plugs from the seawater pickup pump (front, starboard side).

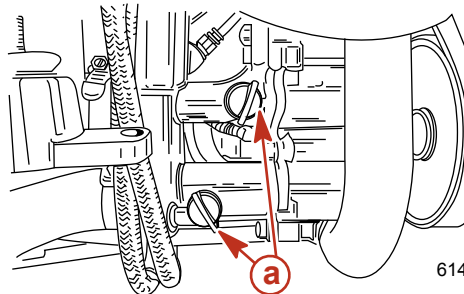

6140

**a** - Blue drain plugs

5. Verify that water is draining from each opening.
6. Allow the system to drain for a minimum of five minutes. Mercury MerCruiser recommends leaving the drain system open while transporting the boat or while performing other maintenance to ensure that all water is drained.
7. Crank the engine over slightly with starter motor to purge any water trapped in the seawater pickup pump. Do not allow the engine to start.
8. Prior to launching the boat or starting the engine, close the drain system by installing the four blue drain plugs.
9. Open the seacock, if equipped, or unplug and reconnect the water inlet hose prior to operating the engine.

## BOAT OUT OF THE WATER

**NOTE:** Use this procedure if your engine is not equipped with an air actuated single point drain system or if the single point drain system fails.

1. Place the boat on a level surface to ensure complete draining of the system.

2. Remove three blue drain plugs: one from the distribution housing (lower front, port side) and two from the seawater pickup pump (front, starboard side).

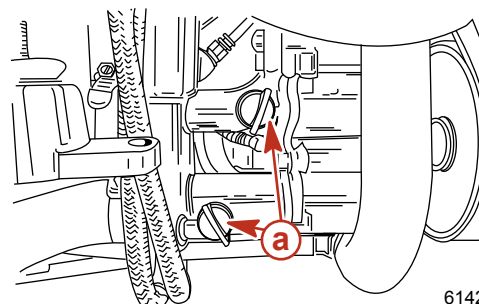
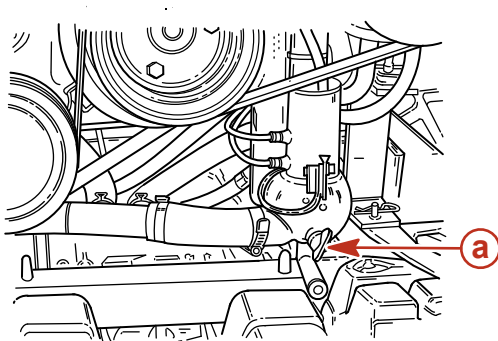

6142

**a** - Blue drain plug

3. Verify that water is draining from each opening.
4. Allow the system to drain for a minimum of five minutes. Mercury MerCruiser recommends leaving the drain system open while transporting the boat or while performing other maintenance to ensure that all water is drained.
5. Crank the engine over slightly with starter motor to purge any water trapped in the seawater pickup pump. Do not allow the engine to start.
6. Prior to launching the boat or starting the engine, close the drain system by installing the three blue drain plugs.

## Multi-Point Drain (MPD) System

### BOAT OUT OF THE WATER

1. Place the boat on a level surface to ensure complete draining of the system.
2. Remove the blue drain plugs from the following locations. If necessary, clean out the drain holes using a stiff piece of wire. Do so until the entire system is drained.
  - a. Port and starboard side of cylinder block
  - b. Bottom of exhaust manifolds

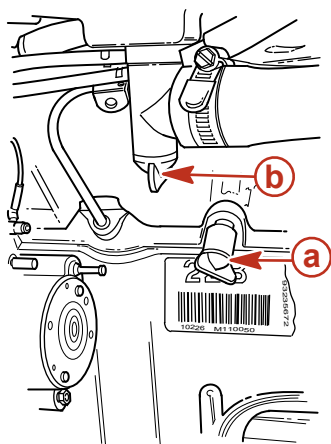

**a** - Cylinder block drain plug

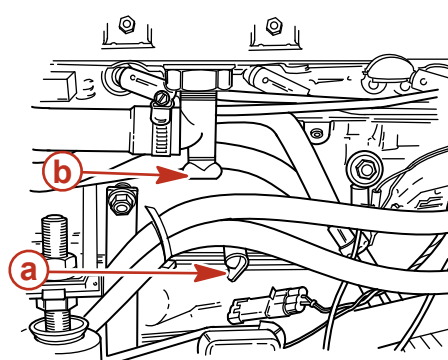

6129

**b** - Exhaust manifold drain plug

- c. Water-circulating pump hose

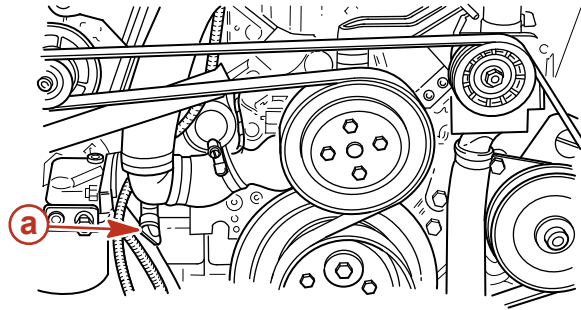

6143

**a** - Drain plug

- d. Fuel-cooler-to-thermostat-housing hose

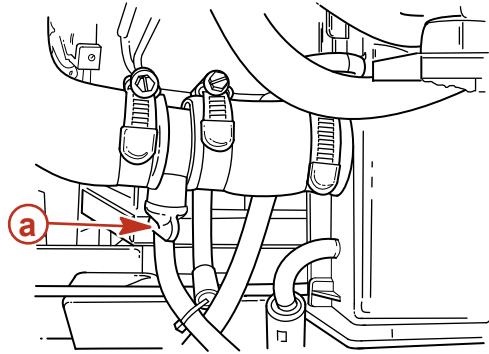

6144

**a** - Drain plug

- e. Check valve

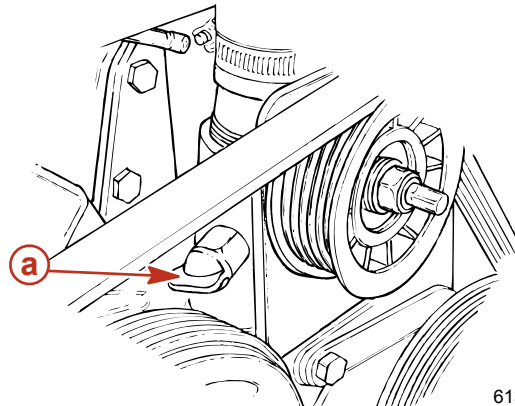

6131

**a** - Drain plug (if equipped)

3. On models with a seawater pickup pump, remove the two blue drain plugs. If the seawater pickup pump does not have blue drain plugs, or you are unable to access them, loosen the clamps and remove both hoses.

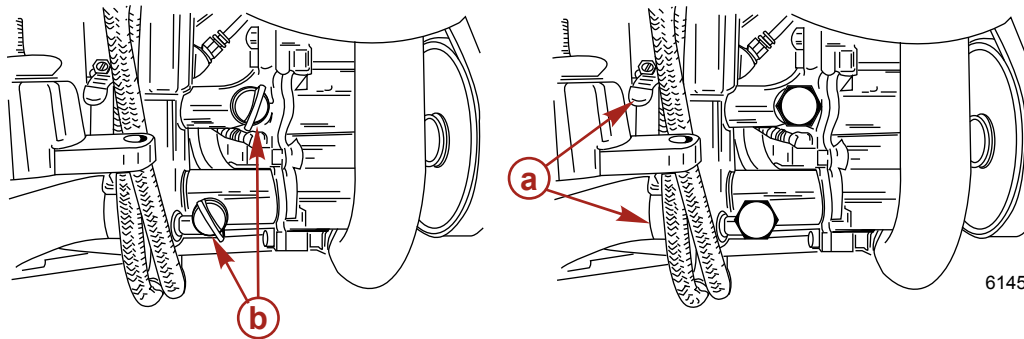

a - Hose clamps

b - Blue drain plugs

4. Crank the engine over slightly with the starter motor to purge any water trapped in the seawater pickup pump. Do not allow the engine to start.
5. After the cooling system has been drained completely, install the drain plugs, reconnect the hoses, and tighten all hose clamps securely.

## BOAT IN THE WATER

1. Close the seacock (if equipped) or remove and plug the water inlet hose.
2. Remove the blue drain plugs from the following locations. If necessary, clean out the drain holes using a stiff piece of wire. Do so until the entire system is drained.
  - a. Port and starboard side of cylinder block
  - b. Bottom of exhaust manifolds

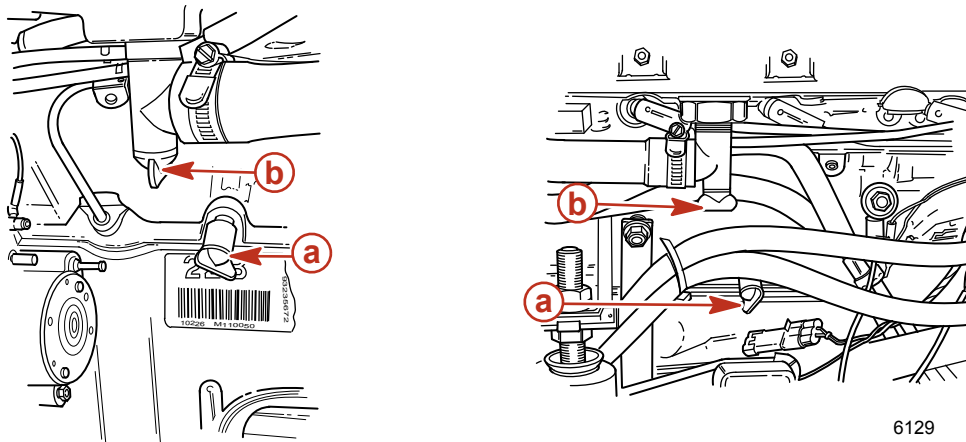

a - Cylinder block drain plug

b - Exhaust manifold drain plug

- c. Water-circulating pump hose

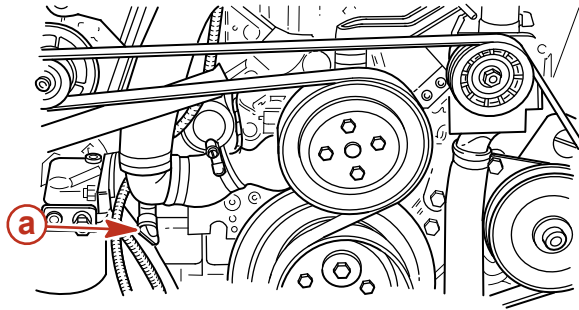

6143

**a** - Drain plug

- d. Fuel-cooler-to-thermostat-housing hose

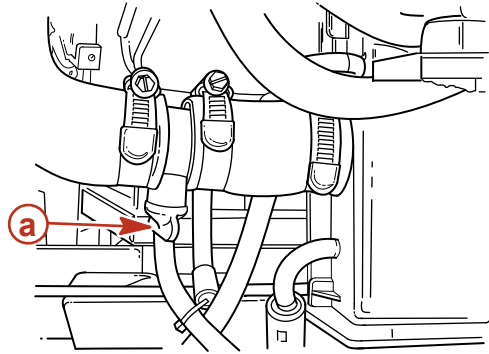

6144

**a** - Drain plug

- e. Check valve

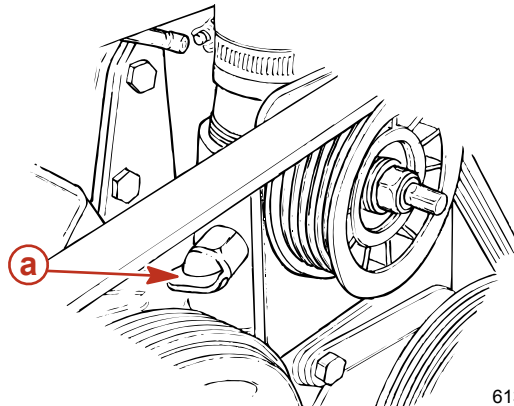

6131

**a** - Drain plug (if equipped)



- On models with a seawater pickup pump, remove the two blue drain plugs. If the seawater pickup pump does not have blue drain plugs, or you are unable to access them, loosen the clamps and remove both hoses.

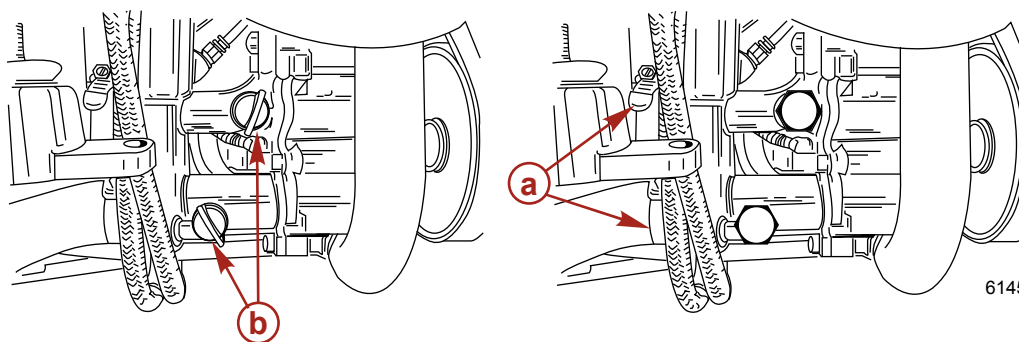

a - Hose clamps

b - Blue drain plugs

- Crank the engine over slightly with the starter motor to purge any water trapped in the seawater pickup pump. Do not allow the engine to start.
- Before launching the boat or starting the engine, close the drain system by installing the blue drain plugs.
- Open the seacock, if equipped, or unplug and reconnect the water inlet hose before operating the engine.

## Battery Storage

Whenever the battery will be stored for an extended period of time, be sure the cells are full of water and the battery is fully charged and in good operating condition. It should be clean and free of leaks. Follow the battery manufacturer's instructions for storage.

## Power Package Recommissioning

- Ensure that all cooling system hoses are connected properly and hose clamps are tight.

### ⚠ CAUTION

Reversing the battery cables or connection order will damage the electrical system. When installing the battery, be sure to connect the positive (+) battery cable to the positive (+) battery terminal first, and the negative (-) battery cable to the negative (-) battery terminal second.

- Install a fully charged battery. Clean the battery cable clamps and terminals and reconnect cables. Tighten each cable clamp securely when connecting.
- Coat the terminal connections with a battery terminal anti-corrosion agent.
- Perform all the checks in the before starting column of the **Operation Chart**.

### ⚠ CAUTION

Overheating from insufficient cooling water will cause engine and drive system damage. Ensure that there is sufficient water always available at water inlet holes during operation.

- Start the engine and closely observe instrumentation to ensure that all systems are functioning correctly.
- Carefully inspect the engine for fuel, oil, fluid, water and exhaust leaks.
- Inspect the steering system, shift and throttle control for proper operation.

## Notes:

# Section 7 - Troubleshooting

## Table of Contents

Diagnosing EFI Problems.....	92	Excessive Engine Temperature.....	93
Engine Guardian System.....	92	Insufficient Engine Temperature.....	93
Starter Motor Will Not Crank Engine, Or Cranks Slow.....	92	Low Engine Oil Pressure.....	93
Engine Will Not Start Or Is Hard To Start.....	92	Battery Will Not Come Up On Charge.....	94
Engine Runs Rough, Misses And/Or Backfires.....	92	Remote Control Operates Hard, Binds, Has Excessive Free-play Or Makes Unusual Sounds.....	94
Poor Performance.....	93	Steering Wheel Turns Hard Or Jerky.....	94

## Diagnosing EFI Problems

Your authorized Mercury MerCruiser dealer has the proper service tools for diagnosing problems on Electronic Fuel Injection (EFI) Systems. The Electronic Control Module (ECM) on these engines has the ability to detect some problems with the system when they occur, and store a Trouble Code in the ECM's memory. This code can then be read later by a service technician using a special diagnostic tool.

## Engine Guardian System

The Engine Guardian System monitors the critical sensors on the engine for any early indications of problems. The system will respond to a problem by emitting a continuous beep and/or reducing engine power in order to provide engine protection.

If Guardian System has been activated, reduce throttle speed. The horn will turn off when throttle speed is within the allowable limit. Consult an authorized Mercury MerCruiser dealer for assistance.

## Starter Motor Will Not Crank Engine, Or Cranks Slow

Possible Cause	Remedy
Battery switch turned off.	Turn the switch on.
Remote control not in neutral position.	Position the control lever in neutral.
Open circuit breaker or blown fuse.	Check and reset the circuit breaker or replace fuse.
Loose or dirty electrical connections or damaged wiring.	Check all electrical connections and wires (especially battery cables). Clean and tighten all faulty connections.
Bad battery or low battery voltage.	Test the battery and charge if necessary; replace if bad.
Lanyard stop switch activated.	Check the lanyard stop switch.

## Engine Will Not Start Or Is Hard To Start

Possible Cause	Remedy
Lanyard stop switch activated.	Check the lanyard stop switch.
Improper starting procedure.	Read the starting procedure.
Insufficient fuel supply.	Fill fuel tank or open valve.
Faulty ignition system component.	Service the ignition system.
Clogged fuel filter.	Replace fuel filter.
Stale or contaminated fuel.	Drain fuel tank. Fill with fresh fuel.
Fuel line or tank vent line kinked or clogged.	Replace kinked lines or blow out lines with compressed air to remove obstruction.
Faulty wire connections.	Check wire connections.
EFI system fault.	Have EFI System checked by an authorized Mercury MerCruiser dealer.

## Engine Runs Rough, Misses And/Or Backfires

Possible Cause	Remedy
Clogged fuel filter.	Replace filter.
Stale or contaminated fuel.	If contaminated, drain tank. Fill with fresh fuel.

Possible Cause	Remedy
Kinked or clogged fuel line or fuel tank vent line.	Replace kinked lines or blow out lines with compressed air to remove obstruction.
Flame Arrestor dirty.	Clean Flame Arrestor.
Faulty ignition system component.	Service ignition system.
Idle speed too low.	Have EFI system checked by an authorized Mercury MerCruiser dealer.
EFI System fault.	Have EFI System checked by an authorized Mercury MerCruiser dealer.

## Poor Performance

Possible Cause	Remedy
Throttle not fully open.	Inspect the throttle cable and linkages for proper operation.
Damaged or improper propeller.	Replace the propeller.
Excessive bilge water.	Drain and check for cause of entry.
Boat overloaded or load improperly distributed.	Reduce load or redistribute load more evenly.
Flame arrestor dirty.	Clean the flame arrestor.
Boat bottom fouled or damaged.	Clean or repair as necessary.
Ignition problem.	See <b>Engine Runs Rough, Misses or Backfires</b> .
Engine overheating.	See <b>Excessive Engine Temperature</b> .
EFI System fault	Have EFI System checked by an authorized Mercury MerCruiser dealer.

## Excessive Engine Temperature

Possible Cause	Remedy
Water inlet or seacock closed.	Open.
Drive belt loose or in poor condition.	Replace or adjust belt.
Seawater pickups or sea strainer obstructed.	Remove obstruction.
Faulty thermostat.	Replace.
Coolant level (if equipped) low in closed cooling section.	Check for cause of low coolant level and repair. Fill system with proper coolant solution.
Heat Exchanger or Fluid Cooler plugged with foreign material	Clean Heat Exchanger, Engine Oil Cooler, and Transmission Oil Cooler (if equipped).
Loss of pressure in closed cooling section.	Check for leaks. Clean, inspect and test pressure cap.
Faulty seawater pickup pump.	Repair.
Seawater discharge restricted or plugged.	Clean exhaust elbows.

## Insufficient Engine Temperature

Possible Cause	Remedy
Faulty thermostat.	Replace.

## Low Engine Oil Pressure

Possible Cause	Remedy
Insufficient oil in crankcase.	Check and add oil.

Possible Cause	Remedy
Excessive oil in crankcase (causing it to become aerated).	Check and remove required amount of oil. Check for cause of excessive oil (improper filling).
Diluted or improper viscosity oil.	Change oil and oil filter, using correct grade and viscosity oil. Determine cause for dilution (excessive idling).

## Battery Will Not Come Up On Charge

Possible Cause	Remedy
Excessive current draw from battery.	Turn off non-essential accessories.
Alternator drive belt loose or in poor condition.	Replace and/or adjust.
Unacceptable battery condition.	Test battery, replace if necessary.
Loose or dirty electrical connections or damaged wiring.	Check all associated electrical connections and wires (especially battery cables). Clean and tighten faulty connections. Repair or replace damaged wiring.
Faulty alternator	Test alternator output, replace if necessary.

## Remote Control Operates Hard, Binds, Has Excessive Free-play Or Makes Unusual Sounds

Possible Cause	Remedy
Insufficient lubrication on shift and throttle linkage fasteners.	Lubricate.
Obstruction in shift or throttle linkages.	Remove obstruction.
Loose or missing shift and throttle linkages.	Check all throttle linkages. If any are loose or missing, see authorized Mercury MerCruiser dealer immediately.
Shift or throttle cable kinked.	Straighten cable or have authorized Mercury MerCruiser dealer replace cable if damaged beyond repair.

## Steering Wheel Turns Hard Or Jerky

Possible Cause	Remedy
Low power steering pump fluid level.	Check for leak. Refill system with fluid.
Drive belt loose or in poor condition.	Replace and/or adjust.
Insufficient lubrication on steering components.	Lubricate.
Loose or missing steering fasteners or parts.	Check all parts and fasteners if any are loose or missing, see authorized Mercury MerCruiser dealer immediately.
Contaminated power steering fluid.	See authorized Mercury MerCruiser dealer.

# Section 8 - Customer Assistance Information

## Table of Contents

---

Owner Service Assistance.....	96	Parts And Accessories Inquiries .....	97
Local Repair Service .....	96	Resolving A Problem .....	97
Service Away From Home .....	96	Mercury Marine Service Offices .....	97
Stolen Power Package .....	96	Ordering Literature.....	98
Attention Required After Submersion .....	96	United States and Canada .....	98
Replacement Service Parts .....	96	Outside The United States and Canada .....	98

---

## Owner Service Assistance

### Local Repair Service

Always return your Mercury MerCruiser powered boat to your authorized dealer should the need for service arise. Only he has the factory trained mechanics, knowledge, special tools and equipment and the genuine Quicksilver parts and accessories<sup>1</sup> to properly service your engine should the need occur. He knows your engine best.

### Service Away From Home

If you are away from your local dealer and the need arises for service, contact the nearest authorized dealer. Refer to the Yellow Pages of the telephone directory. If, for any reason, you cannot obtain service, contact the nearest Regional Service Center. Outside the United States and Canada, contact the nearest Marine Power International Service Center.

### Stolen Power Package

If your power package is stolen, immediately advise the local authorities and Mercury Marine of the model and serial numbers and to whom the recovery is to be reported. This information is maintained in a database at Mercury Marine to aid authorities and dealers in recovery of stolen power packages.

### Attention Required After Submersion

1. Before recovery, contact an authorized Mercury MerCruiser dealer.
2. After recovery, immediate service by an authorized Mercury MerCruiser dealer is required to reduce the possibility of serious engine damage.

### Replacement Service Parts

#### **WARNING**

**Avoid fire or explosion hazard. Electrical, ignition, and fuel system components on Mercury Marine products comply with U.S. Coast Guard rules to minimize risk of fire or explosion. Do not use replacement electrical or fuel system components that do not comply with these rules. When servicing the electrical and fuel systems, properly install and tighten all components.**

Marine engines are expected to operate at or near full throttle for most of their life. They are also expected to operate in both fresh and saltwater environments. These conditions require numerous special parts. Care should be exercised when replacing marine engine parts as specifications are quite different from those of the standard automotive engine.

For example, one of the most important, and probably the least suspected special replacement part, is the cylinder head gasket. Since saltwater is highly corrosive, the steel-type automotive head gasket cannot be used. A marine engine head gasket uses special materials to resist corrosive action.

Since marine engines must be capable of running at or near maximum RPM much of the time, special valve springs, valve lifters, pistons, bearings, camshafts and other heavy duty moving parts are required for long life and peak performance.

These are but a few of the many special modifications that are required in Mercury MerCruiser marine engines to provide long life and dependable performance.

1. Quicksilver parts and accessories are engineered and built by Mercury Marine, specifically for Mercury MerCruiser sterndrives and inboards.



## PARTS AND ACCESSORIES INQUIRIES

All inquiries concerning Quicksilver replacement parts and accessories should be directed to your local authorized dealer. The dealer has the necessary information to order parts and accessories for you should he not have them in stock. Only authorized dealers can purchase genuine Quicksilver parts and accessories from the factory. Mercury Marine does not sell to unauthorized dealers or retail customers. When inquiring on parts and accessories, the dealer requires the **engine model** and **serial numbers** to order the correct parts.

## Resolving A Problem

Satisfaction with your Mercury MerCruiser product is very important to your dealer and to us. If you ever have a problem, question or concern about your power package, contact your dealer or any authorized Mercury MerCruiser dealership. If additional assistance is required, take these steps:

1. Talk with the dealership's sales manager or service manager. If this has already been done, then contact the owner of the dealership.
2. Should you have a question, concern or problem that cannot be resolved by your dealership, please contact Mercury Marine Service Office for assistance. Mercury Marine will work with you and your dealership to resolve all problems.

The following information will be needed by the service office:

- Your name and address
- Daytime telephone number
- Model and serial numbers for your power package
- The name and address of your dealership
- Nature of problem

Mercury Marine Service Offices are listed on the next page.

## Mercury Marine Service Offices

For assistance, call, fax or write. Please include your daytime telephone number with mail and fax correspondence.

Telephone	Fax	Mail
(405) 743 6566	(405) 743 6570	Mercury MerCruiser 3003 N. Perkins Rd. Stillwater, OK 74075
(905) 567 MERC (6372)	(905) 567 8515	Mercury Marine Ltd. 2395 Meadowpine Blvd. Mississauga, Ontario L5N 7W6 Canada
(61) (3) 9791 5822	(61) (3) 9793 5880	Mercury Marine Australia 132-140 Frankston Road Dandenong, Victoria 3164 Australia
(32) (87) 32 32 11	(32) (87) 31 19 65	Marine Power - Europe, Inc. Parc Industriel de Petit-Rechain B-4800 Verviers, Belgium

## Section 8 - Customer Assistance Information

---

Telephone	Fax	Mail
(954) 744 3500	(954) 744 3535	Mercury Marine - Latin America & Caribbean 11650 Interchange Circle North, Miramar, FL 33025 U.S.A.
(81) 53 423 2500	(81) 53 423 2510	Mercury Marine - Japan 283-1 Anshin-cho Hamamatsu, Shizuoka 435-0005 Japan
(65) 6546 6160	(65) 6546 7789	Mercury Marine Singapore 72 Loyang Way , 508762 Singapore

## Ordering Literature

Before ordering literature, please have the following information about your power package available:

- Model
- Serial Number
- Horsepower
- Year built

## United States and Canada

For information on additional literature that is available for your particular Mercury MerCruiser power package and how to order that literature contact your nearest dealer or contact

Mercury Marine Publications  
P.O. Box 1939  
Fond du Lac, WI 54936-1939  
(920) 929-5110  
Fax (920) 929-4894

## Outside The United States and Canada

Contact your nearest dealer or Marine Power Service Center for information on additional literature that is available for your particular Mercury MerCruiser power package and how to order that literature.

Please return with payment to:

Mercury Marine  
Attn: Publications Department  
W6250 West Pioneer Road  
P.O. Box 1939  
Fond du Lac, WI 54936-1939

**Ship To: (Please Print Or Type - This Is Your Shipping Label)**

Name

Address

City State ZIP